



Instruction Bulletin
VD0C06S304E
January 1999
Price \$30.00
Replaces VD0C06S304D 02/98

ALTIVAR® 66

**Adjustable Speed Drive Controllers
For Asynchronous Motors**

User's Manual

**Constant and Variable Torque:
1 to 400 hp, 460 V and 1 to 50 hp, 230 V
Receiving, Installation and Start-Up**



Telemecanique



SQUARE D

DANGER

HAZARDOUS VOLTAGE.

- Read and understand this bulletin in its entirety before installing or operating ALTIVAR 66 drive controllers. Installation, adjustment, repair and maintenance of these drive controllers must be performed by qualified personnel.
- Disconnect all power before servicing drive controller. WAIT ONE MINUTE until DC bus capacitors discharge, then measure DC bus capacitor voltage between PA and (-) terminals to verify DC voltage is less than 45 V (see pages 78 through 80). The DC bus LED is not an accurate indication of the absence of DC bus voltage.
- DO NOT short across DC bus capacitors or touch unshielded components or terminal strip screw connections with voltage present.
- Install all covers and close door before applying power or starting and stopping the drive controller.
- User is responsible for conforming to all applicable code requirements with respect to grounding all equipment. For drive controller grounding points, refer to the terminal connection drawings on pages 41, 42, and 43.
- Many parts in this drive controller, including printed wiring boards, operate at line voltage. DO NOT TOUCH. Use only electrically insulated tools.

Before servicing drive controller:

- Disconnect all power.
- Place a "DO NOT TURN ON" label on drive controller disconnect.
- Lock disconnect in open position.

Failure to follow these instructions will result in death or serious injury.

Square D and  are registered trademarks of Square D Company. ALTIVAR is a registered trademark of Schneider Electric, S.A.

© 1994, 1998, 1999 Schneider S.A. All rights reserved. This document may not be copied in whole or in part, or transferred to any other media, without the written permission of Schneider S.A.

Electrical equipment should be serviced only by qualified electrical maintenance personnel. No responsibility is assumed by Schneider S.A. for any consequences arising out of the use of this material.

CHAPTER 1—RECEIVING AND INSTALLATION	1
INTRODUCTION	2
Scope	2
Documentation List	2
Revision Level	2
HAZARD LABELING	3
TECHNICAL CHARACTERISTICS	6
DIMENSIONS & WEIGHTS FOR WALL OR PANEL MOUNTING	15
HANDLING DRIVE CONTROLLERS	19
PRELIMINARY INSPECTION	20
INSTALLATION PRECAUTIONS	20
MOUNTING IN GENERAL PURPOSE METAL ENCLOSURE	23
Ventilation	23
MOUNTING IN TYPE 12 (IP54) METAL ENCLOSURE	24
Calculating Non-Ventilated Enclosure Size	24
Ventilation	26
Recess Mounting	26
CHAPTER 2—WIRING	29
WIRING	30
General Wiring Practices	30
Branch Circuit Connections	30
Control Wiring Precautions	38
Output Wiring Precautions	39
Grounding	40
TERMINAL STRIP LOCATIONS	41
POWER WIRING	44
CONTROL WIRING	46
ELECTROMAGNETIC COMPATIBILITY (EMC)	48
Installing the Ferrite Cores	49
USING THE LOGIC INPUTS (J12)	52
USING THE LOGIC OUTPUTS (J12)	53
USING THE SPEED REFERENCE INPUTS (J13)	54
USING THE ANALOG OUTPUTS (J13)	55
USING THE RELAY OUTPUTS (J1)	55
REMOVAL OF CL1, CL2 JUMPERS	56
CONTROL CIRCUIT DIAGRAMS	57
3-Wire Control	57
2-Wire Control	57
2-Wire Control with Isolation Contactor on Line Side (coast to stop)	58
EQUIPMENT RECOMMENDATIONS	59
Mounting and Replacing Line Power Fuses in ATV66C10N4 to C19N4 Drive Controllers	64
Replacing Line Power Fuses in ATV66C23N41 to C31N41 Drive Controllers	64

CHAPTER 3—START-UP	63
INTRODUCTION	66
FACTORY SETTINGS	67
CONTROL TYPES	68
Normal	68
High Torque	69
Special	69
NOLD (No Load)	69
MOTOR THERMAL OVERLOAD PROTECTION	70
ADJUSTMENT OF MOTOR OVERLOAD	71
AVAILABLE MOTOR TORQUE	72
Continuous Duty	72
Overtorque Capability and Speed Range	72
Overspeed Operation ($f \geq 50/60$ Hz)	73
Regenerative Operation	73
Driving Torque Production Envelope	73
MOTOR CONSIDERATIONS	74
Motor Insulation	75
Motors in Parallel	75
Output Contactor Between Motor and Drive Controller	75
Additional Motor Connected Downstream of the Drive Controller	75
Using a Synchronous Permanent Magnet or Wound-Field Motor	76
Using a Synchronous Reluctance Motor	76
CHAPTER 4—DIAGNOSTICS	75
PRECAUTIONS	78
PROCEDURE 1: BUS VOLTAGE MEASUREMENT	78
PROCEDURE 2: INPUT LINE VOLTAGE MEASUREMENT	81
PROCEDURE 3: CHECKING PERIPHERAL EQUIPMENT	81
PROCEDURE 4: IDENTIFYING THE FIRMWARE VERSION	82
PREVENTIVE MAINTENANCE	83
RESETTABLE/RENEWABLE PARTS	84
Resettable Parts	84
Renewable Parts	84
F4A, F4B, and F4C Bus Fuse Test Procedure: ATV66C10N41 to ATV66C31N41	85
LEDS	88
FAULT MESSAGES	88
APPENDIX A—SPARE PARTS LIST	93
INDEX	99

LIST OF FIGURES

Figure 1:	Hazard Labeling	3
Figure 2:	Sample Nameplate	3
Figure 3:	Locating Nameplate on ATV66U41N4 to D23N4 and ATV66U41M2 to ATV66D16M2	4
Figure 4:	Locating Nameplate on ATV66D33N4 to D79N4 and ATV66D23M2 to D46M2	4
Figure 5:	Locating Nameplate on ATV66C10N4 to C19N4	5
Figure 6:	Locating Nameplate on ATV66C23N41 to C31N41	5
Figure 7:	Mounting Information for ATV66U41N4 to D23N4 and ATV66U41M2 to D16M2	15
Figure 8:	Mounting Information for ATV66D33N4 to D79N4 and ATV66D33M2 to D46M2	16
Figure 9:	Mounting Information for ATV66C10N4 to C19N4	17
Figure 10:	Mounting Information for ATV66C23N41 to C31N41	18
Figure 11:	Hoisting ATV66D54N4 to C31N41 and ATV66D46M2	19
Figure 12:	Clearances for Drive Controllers	21
Figure 13:	Ventilation for ATV66U41N4 to C31N41 and ATV66U41M2 to D46M2	23
Figure 14:	Grounding Multiple Drive Controllers	40
Figure 15:	Terminal Strip Locations: ATV66U41N4 to D79N4 and ATV66U41M2 to D46M2	41
Figure 16:	Terminal Strip Locations: ATV66C10N4 to C19N4	42
Figure 17:	Terminal Strip Locations: ATV66C23N41 to C31N41	43
Figure 18:	Terminal Strip Connections for Control Board	46
Figure 19:	Typical Diagram of Control Wiring at Drive Controller	50
Figure 20:	Typical Diagram of Motor Power Wiring at Drive Controller	51
Figure 21:	Operating the Logic Inputs from Internal Power Supply	52
Figure 22:	Operating the Logic Inputs from External Power Supply	52
Figure 23:	Operating the Logic Outputs from Internal Power Supply	53
Figure 24:	Operating the Logic Outputs from External Power Supply	53
Figure 25:	Using Speed Reference Inputs	54
Figure 26:	Analog Outputs	55
Figure 27:	Relay Outputs	55
Figure 28:	CL1, CL2 Jumper Removal	56
Figure 29:	Recommended 3-Wire Control Circuit Diagram	57
Figure 30:	2-Wire Control Circuit Diagram	57
Figure 31:	2-Wire Control Circuit Diagram with Isolation Contactor (see Table 21)	58
Figure 32:	Thermal Curves (Constant Torque)	71
Figure 33:	Typical Constant Torque Curves	74
Figure 34:	Typical Variable Torque Curves	74
Figure 35:	Motors in Parallel	75
Figure 36:	Connecting an Additional Motor	75
Figure 37:	Location of PA and – Terminals: ATV66U41N4 to C19N4 and ATV66U41M2 to D46M2	79
Figure 38:	Location of PA and - Terminals: ATV66C23N41 to C31N41	80
Figure 39:	Drive Identification Screen	82
Figure 40:	Main Control Board — Location of Chip Cover	83
Figure 41:	F4A, F4B, F4C Bus Fuse Test Procedure: ATV66C10N4 to C19N4	86
Figure 42:	F4A, F4B, F4C Bus Fuse Test Procedure: ATV66C23N41 to C31N41	87
Figure 43:	Drive Controller LEDs	88
Figure 44:	ATV66C10N4 to ATV66C19N4	92
Figure 45:	ATV66C10N4 to ATV66C19N4	93

LIST OF TABLES

Table 1:	Constant Torque Drive Controller Ratings 460 V	6
Table 2:	Variable Torque Drive Controller Ratings 460 V	8
Table 3:	Variable Torque, Low Noise Drive Controller Ratings 460 V	9
Table 4:	Recommended Braking Resistance Values.	10
Table 5:	Constant Torque Drive Controller Ratings, 208 V / 230 V	11
Table 6:	Variable Torque Drive Controller Ratings 208 V/230 V	11
Table 7:	Variable Torque, Low Noise Drive Controller Ratings 208 V / 230 V	12
Table 8:	Recommended Braking Resistance Values.	12
Table 9:	Specifications.	13
Table 10:	Flow Rates for ALTIVAR 66 Drive Controller Fans	24
Table 11:	Recess Mounting Kits	27
Table 12:	Input Line Currents for Selecting Branch Circuit Conductors, 460 V CT	32
Table 13:	Input Line Currents for Selecting Branch Circuit Conductors, 460 V VT	34
Table 14:	Input Line Currents for Selecting Branch Circuit Conductors, 460 V VTLN.	36
Table 15:	Input Line Currents for Selecting Branch Circuit Conductors, 208-230 V CT	37
Table 16:	Input Line Currents for Selecting Branch Circuit Conductors, 208/230 V VT	37
Table 17:	Input Line Currents for Selecting Branch Circuit Conductors, 208/230 V VTLN	38
Table 18:	Power Terminal Strip Characteristics [1]	44
Table 19:	Power Terminal Wire Range	45
Table 20:	Control Terminal Strip Characteristics	47
Table 21:	Recommended Equipment for 1 to 400 hp 460 V Drive Controllers[1]	59
Table 22:	Recommended Semiconductor Fuses for 1 - 400 hp 460 V Controllers	60
Table 23:	Maximum Allowable Line Fuse (F1 to F3) for 460 V Drive Controllers	62
Table 24:	Recommended Equipment for 1 to 50 hp 208/230 V Drive Controllers[1].	62
Table 25:	Maximum Allowable Line Fuse (F1 to F3) for 208/230 V Drive Controllers	63
Table 26:	Recommended Equipment for all Drive Controllers.	63
Table 27:	Factory Settings – Functions	67
Table 28:	Factory Settings – Inputs and Outputs.	68
Table 29:	Operating Non-Standard Motors	76
Table 30:	Fault Messages	88
Table 31:	Fault Messages from Option Modules	92
Table 32:	Spare Parts List	94

CHAPTER 1—RECEIVING AND INSTALLATION

INTRODUCTION 2
 Scope 2
 Documentation List 2
 Revision Level. 2
HAZARD LABELING 3
NAMEPLATES AND SERIAL NUMBERS. 3
TECHNICAL CHARACTERISTICS 6
 460 V Controllers 6
 208 V and 230 V Controllers. 11
 Controller Specifications 13
DIMENSIONS & WEIGHTS FOR WALL OR PANEL MOUNTING 15
HANDLING DRIVE CONTROLLERS 19
PRELIMINARY INSPECTION 20
INSTALLATION PRECAUTIONS. 20
MOUNTING IN GENERAL PURPOSE METAL ENCLOSURE 23
 Ventilation 23
MOUNTING IN TYPE 12 (IP54) METAL ENCLOSURE 24
 Calculating Non-Ventilated Enclosure Size 24
 Ventilation 26
 Recess Mounting 26

INTRODUCTION

ALTIVAR® 66 is a family of 1 to 400 hp, 2.2 to 250 kW, 460 V and 1 to 50 hp, 2.2 to 37 kW, 230 V adjustable frequency AC drive controllers. The 460 V line consists of 19 devices in 7 outlines, the 230 V line consists of 8 devices in 5 outlines. Capable of controlling either constant or variable torque loads and designed to handle simple or complex applications, ALTIVAR 66 drive controllers may function as stand-alone drive controllers or as part of complex drive systems.

The ALTIVAR 66 family also includes optional peripherals. Consult catalog for descriptions.

Scope

This manual covers receiving, installation, and startup of the 460 V and 230 V lines of ALTIVAR 66 drive controllers. It also includes information on diagnostics. For configuration and adjustment of the drive controller parameters, refer to the Level 1 & 2 Configuration manual.

Many options are available for the ALTIVAR 66 drive controller. Refer to the catalog for a description of these options. A manual or instruction sheet is provided with each option.

Documentation List

The following ALTIVAR 66 drive controller documents are available:

- Receiving, Installation, and Start-Up: VD0C06S304_
- Level 1 & 2 Configuration: VD0C06S305_
- Dynamic Braking: VD0C06S908_
- Catalog: VD0C06S201_

Additional documentation is provided with the optional peripherals.

Revision Level

This document, Revision E, replaces VD0C06S304D dated February, 1998.

HAZARD LABELING

The ALTIVAR 66 drive controller is shipped with an English safety label applied to the control board. If a Spanish, German, or French label is required, affix it to the main control board above the English label (see Figure 1). Do not obstruct the English label.

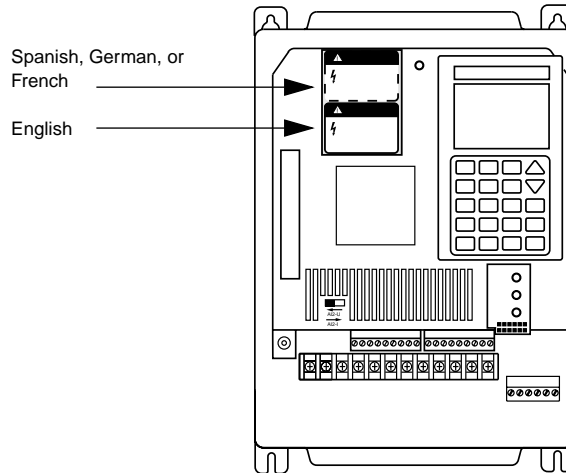

Figure 1: Hazard Labeling

The ATV66C10N4 to ATV66C31N41 drive controllers also ship with a similar English safety label applied to the front door. Affix a Spanish, German, or French label above the English label as required. See Figure 9 and Figure 10.

NAMEPLATES AND SERIAL NUMBERS

For most of the drive controllers, the nameplate is found on the bottom right corner of the right side of the controller. The exceptions are the ATV66C23N41 through C31N41, where the plate is located on the inside of the front door.

Serial numbers are usually found next to the nameplate, except on ATV66D33N4 to D46N4, and ATV66D23M2 to D33M2, where the serial number is in two separate locations. For ATV66C10N4 to C19N4 controllers covered by this manual, there is always a "1" as the seventh digit of the serial number.



Figure 2: Sample Nameplate

The following four figures show the location of nameplates and serial numbers.

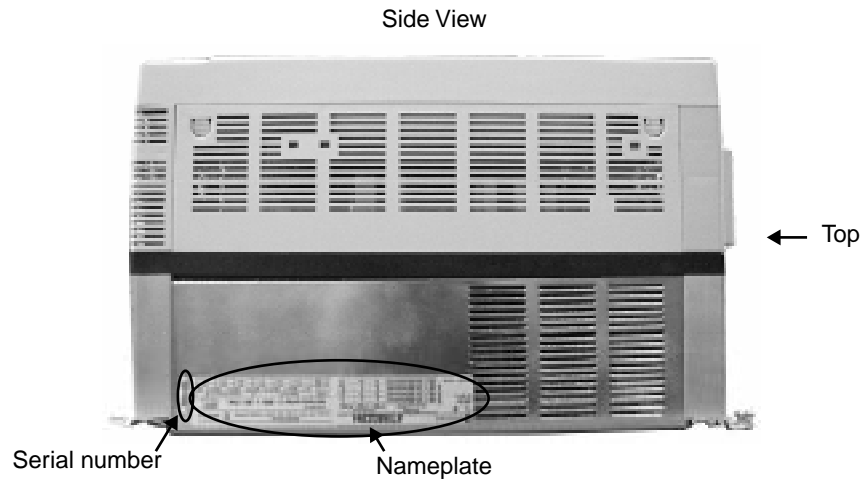

Figure 3: ATV66U41N4 to D23N4 and ATV66U41M2 to ATV66D16M2

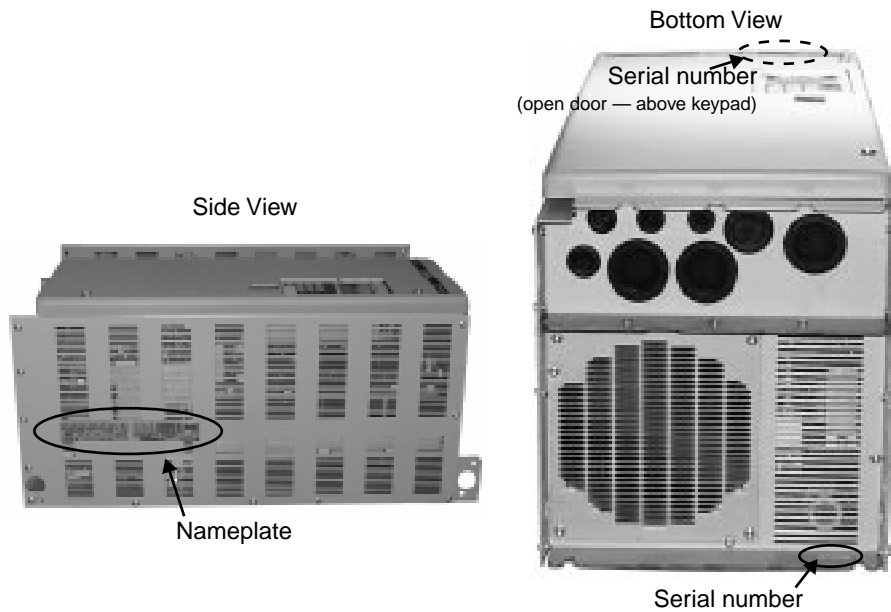

Figure 4: ATV66D33N4 to D79N4 and ATV66D23M2 to D46M2

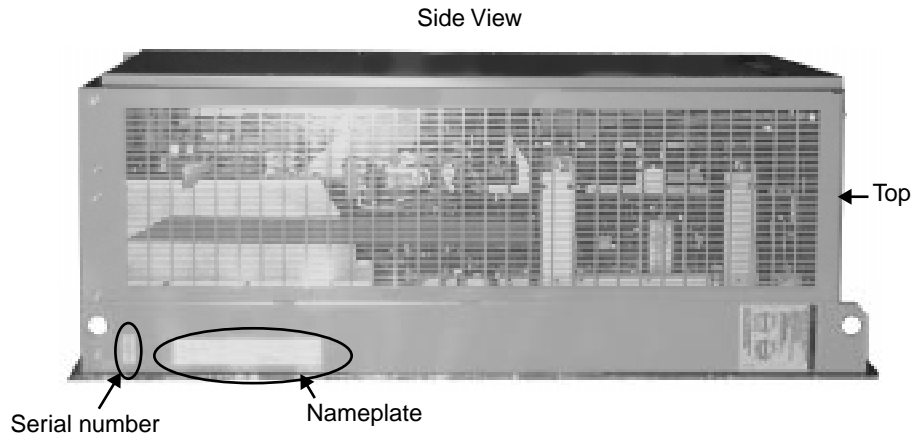

Figure 5: ATV66C10N4 to C19N4

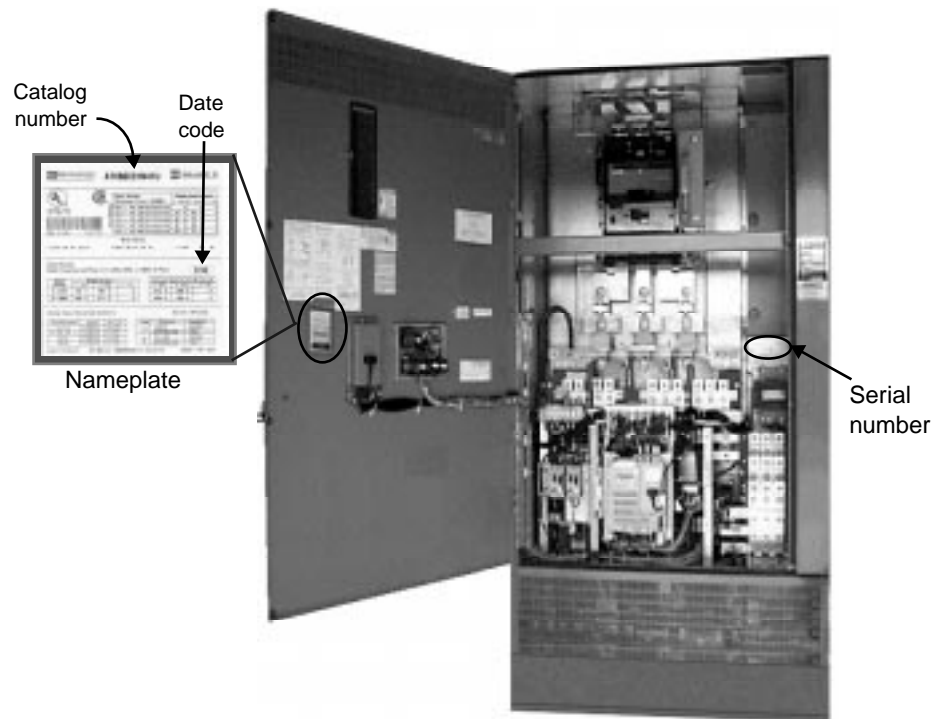

Figure 6: ATV66C23N41 to C31N41

TECHNICAL CHARACTERISTICS

460 V Controllers

The following tables show power and current ratings for 460 V drive controllers when set for constant torque (Table 1); variable torque (Table 2); and variable torque, low noise (Table 3). Table 4 on page 10 lists recommended braking resistance values.

Table 1: Constant Torque Drive Controller Ratings 460 V

400 V \pm 15% and 460 V \pm 15%, 50/60 Hz \pm 5%						
Switching Frequency: ATV66U41N4 to D46N4 = 4 kHz, ATV66D54N4 to C31N41 = 2 kHz						
Outline	Drive Controller Part No.	Motor Power		Output Current A	Max. Transient Current (60 s) A	Total Dissipated Power W
		400 V 50 Hz	460 V 60 Hz			
		kW	hp			
1	ATV66U41N4	0.75	—	2.3	8.0	95.0
		—	1	1.8	7.2	95.0
		1.5	—	4.1	8.0	117
		—	2	3.4	7.2	117
		2.2	—	5.8	8.0	140
		—	3	4.8	7.2	140
	ATV66U54N4	3.0	—	7.8	10.7	165
	ATV66U72N4	4.0	—	10.5	14.2	185
		—	5	7.6	11.4	
2	ATV66U90N4	5.5	—	13	17.7	225
		—	7.5	11	16.5	
	ATV66D12N4	7.5	—	17.6	24.0	290
		—	10	14.0	21.0	
3	ATV66D16N4	11.0	—	24.2	33.0	380
		—	15	21.0	31.5	
	ATV66D23N4	15.0	—	33.0	45.0	530
		—	20	27.0	40.5	
4	ATV66D33N4	22.0	—	48.4	66.0	655
		—	30	40.0	60.0	
	ATV66D46N4	30.0	—	66.0	90.0	880
		—	40	52.0	78.0	
5	ATV66D54N4	37.0	—	79.2	108	885
		—	50	65.0	97.5	
	ATV66D64N4	45.0	—	93.5	127.5	1055
		—	60	77.0	115.5	
	ATV66D79N4	55.0	—	115.5	157.5	1270
		—	75	96.0	144.0	

Table 1: Constant Torque Drive Controller Ratings 460 V (Continued)

Outline	Drive Controller Part No.	Motor Power		Output Current A	Max. Transient Current (60 s) A	Total Dissipated Power W
		400 V 50 Hz kW	460 V 60 Hz hp			
		400 V $\pm 15\%$ and 460 V $\pm 15\%$, 50/60 Hz $\pm 5\%$ Switching Frequency: ATV66U41N4 to D46N4 = 4 kHz, ATV66D54N4 to C31N41 = 2 kHz				
6	ATV66C10N4	75 —	— 100	152 124	207 186	1605
	ATV66C13N4	90 —	— 125	190 156	258 234	1952
	ATV66C15N4	110 —	— 150	226 180	307 270	2251
	ATV66C19N4	132 —	— 200	270 240	367 360	3067
7	ATV66C23N41	160 —	— 250	330 300	450 450	4483
	ATV66C28N41	200 —	— 300	407 360	555 540	5246
	ATV66C31N41	220 —	— 350	449 420	612 630	5966

Table 2: Variable Torque Drive Controller Ratings 460 V

400 V ±15% and 460 V ±15%, 50/60 Hz ±5%						
Switching Frequency: ATV66U41N4 to D46N4 = 4 kHz, ATV66D54N4 to C31N41 = 2 kHz						
Outline	Drive Controller Part No.	Motor Power		Output Current A	Max. Transient Current (60 s) A	Total Dissipated Power W
		400 V 50 Hz kW	460 V 60 Hz hp			
1	ATV66U41N4	0.75	—	2.0	7.8	90.0
		—	1	1.8	5.3	90.0
		1.5	—	3.7	7.8	110
		—	2	3.4	5.3	110
		2.2	—	5.3	7.8	130
		—	3	4.8	5.3	130
	ATV66U54N4	3.0	—	7.1	7.8	150
		4.0	—	9.5	10.5	180
		—	5	7.6	8.4	
ATV66U72N4	5.5	—	11.8	13.0	205	
—	7.5	11.0	12.1			
2	ATV66U90N4	7.5	—	16.0	17.6	265
	—	10	14.0	15.4		
ATV66D12N4	11.0	—	22.0	24.2	350	
	—	15	21.0	23.1		
3	ATV66D16N4	15.0	—	30.0	33.0	480
	—	20	27.0	29.7		
ATV66D23N4	18.5	—	37.0	40.7	560	
	—	25	34.0	37.4		
4	ATV66D33N4	30.0	—	60.0	66.0	800
	—	40	52.0	57.2		
ATV66D46N4	37.0	—	72.0	79.2	910	
	—	50	65.0	71.5		
5	ATV66D54N4	45.0	—	85.0	93.5	960
	—	60	77.0	84.7		
	ATV66D64N4	55.0	—	105	115	1150
—	75	96.0	105			
ATV66D79N4	75.0	—	143	151	1400	
	—	100	124	136		

Table 2: Variable Torque Drive Controller Ratings 460 V (Continued)

400 V ±15% and 460 V ±15%, 50/60 Hz ±5%						
Switching Frequency: ATV66U41N4 to D46N4 = 4 kHz, ATV66D54N4 to C31N41 = 2 kHz						
Outline	Drive Controller Part No.	Motor Power		Output Current A	Max. Transient Current (60 s) A	Total Dissipated Power W
		400 V 50 Hz kW	460 V 60 Hz hp			
6	ATV66C10N4	90.0 —	— 125	170 156	187 171	2271
	ATV66C13N4	110 —	— 150	205 180	226 198	2596
	ATV66C15N4	132 —	— 200	245 240	270 264	3246
	ATV66C19 [1]	160	—	300	330	—
7	ATV66C23N41	200 —	— 300	370 360	407 396	5246
	ATV66C28N41	220 —	— 350	408 420	449 462	5966
	ATV66C31N41	250 —	— 400	460 477	506 525	6624

[1] Unit available for 400 V / 50 Hz supply voltage only.

Table 3: Variable Torque, Low Noise Drive Controller Ratings 460 V

400 V ±15% and 460 V ±15%, 50/60 Hz ±5%						
Switching Frequency: ATV66U41N4 to D46N4 = 10 kHz, ATV66D54N4 to D79N4 = 4 kHz						
Outline	Drive Controller Part No.	Motor Power		Output Current A	Max. Transient Current (60 s) A	Total Dissipated Power W
		400 V 50 Hz kW	460 V 60 Hz hp			
1	ATV66U41N4	0.75	—	2.0	5.8	90.0
		—	1	1.8	5.3	90.0
		1.5	—	3.7	5.8	110
		—	2	3.4	5.3	110
		2.2	—	5.3	5.8	130
		—	3	4.8	5.3	130
	ATV66U54N4	3.0	—	7.1	7.8	150
	ATV66U72N4	4.0 —	— 5	9.5 7.6	10.5 8.4	180
2	ATV66U90N4	5.5	—	11.8	13.0	205
		—	7.5	11.0	12.1	
	ATV66D12N4	7.5 —	— 10	16.0 14.0	17.6 15.4	265

Table 3: Variable Torque, Low Noise Drive Controller Ratings 460 V (Continued)

400 V $\pm 15\%$ and 460 V $\pm 15\%$, 50/60 Hz $\pm 5\%$ Switching Frequency: ATV66U41N4 to D46N4 = 10 kHz, ATV66D54N4 to D79N4 = 4 kHz						
Outline	Drive Controller Part No.	Motor Power		Output Current A	Max. Transient Current (60 s) A	Total Dissipated Power W
		400 V 50 Hz kW	460 V 60 Hz hp			
3	ATV66D16N4	11 —	— 15	22 21	24.2 23.1	350
	ATV66D23N4	15 —	— 20	30 27	33.0 29.7	480
4	ATV66D33N4	22 —	— 30	44 40	48.4 44.0	600
	ATV66D46N4	30 —	— 40	60 52	66.0 57.2	800
5	ATV66D54N4	37 —	— 50	72 65	79.2 71.5	910
	ATV66D64N4	45 —	— 60	85 77	93.5 84.7	960
	ATV66D79N4	55 —	— 75	105 96	115 105	1150

Table 4: Recommended Braking Resistance Values

460 V Drive Controller Part No.	PA/PB Minimum Resistance Ω	460 V Drive Controller Part No.	PA/PB Minimum Resistance Ω
ATV66U41N4	120	ATV66D64N4	5.0
ATV66U54N4	120	ATV66D79N4	5.0
ATV66U72N4	120	ATV66C10N4B [1]	2.5
ATV66U90N4	56	ATV66C13N4B [1]	2.5
ATV66D12N4	56	ATV66C15N4B [1]	2.5
ATV66D16N4	28	ATV66C19N4B [1]	2.5
ATV66D23N4	28	ATV66C23N41	2.0
ATV66D33N4	14	ATV66C28N41	1.25
ATV66D46N4	14	ATV66C31N41	1.25
ATV66D54N4	10		

[1] Refer to page 73 for more information.

208 V and 230 V Controllers

Tables 5 through 7 show the power and current ratings for 208 V and 230 V drive controllers when set for constant torque (Table 5); variable torque (Table 6); and variable torque, low noise (Table 7). Table 8 lists recommended braking resistance values.

Table 5: Constant Torque Drive Controller Ratings, 208 V / 230 V

208 V $\pm 10\%$ and 230 V $\pm 15\%$, 50/60 Hz $\pm 5\%$						
Switching Frequency: ATV66U41M2 to D33M2 = 4 kHz, ATV66D46M2 = 2 kHz						
Outline	Drive Controller Part No.	Motor Power 208/230 V 50/60 Hz		Output Current A	Max. Transient Current (60 s) A	Total Dissipated Power W
		kW	hp			
1	ATV66U41M2	.75	1	4.0	15.9	120
		1.5	2	7.5	15.9	140
		2.2	3	10.6	15.9	170
2	ATV66U72M2	4	5	16.7	25.1	239
	ATV66U90M2	5.5	7.5	24.2	36.3	354
3	ATV66D12M2	7.5	10	30.8	46.2	437
	ATV66D16M2	11	15	46.2	69.3	589
4	ATV66D23M2	15	20	59.4	89.1	728
	ATV66D33M2	22	30	88.0	132	1052
5	ATV66D46M2	30	40	114	171	1439

Table 6: Variable Torque Drive Controller Ratings 208 V/230 V

208 V $\pm 10\%$ and 230 V $\pm 15\%$, 50/60 Hz $\pm 5\%$						
Switching Frequency: ATV66U41M2 to D33M2 = 4 kHz, ATV66D46M2 = 2 kHz						
Outline	Drive Controller Part No.	Motor Power 208/230 V 50/60 Hz		Output Current A	Max. Transient Current (60 s) A	Total Dissipated Power W
		kW	hp			
1	ATV66U41M2	.75	1	4.0	15.4	120
		1.5	2	7.5	15.4	140
		2.2	3	10.6	15.4	170
2	ATV66U72M2	5.5	7.5	24.2	26.6	302
	ATV66U90M2	7.5	10	30.8	33.9	414
3	ATV66D12M2	11.0	15	46.2	50.8	559
4	ATV66D23M2	15.0	20	59.4	65.3	770
		18.5	25	74.8	82.3	831
	ATV66D33M2	30.0	40	114	125	1260
5	ATV66D46M2	37.0	50	143	157	1528

Table 7: Variable Torque, Low Noise Drive Controller Ratings 208 V / 230 V

208 V $\pm 10\%$ and 230 V $\pm 15\%$, 50/60 Hz $\pm 5\%$ Switching Frequency: ATV66U41M2 to D33M2 = 10 kHz, ATV66D46M2 = 4 kHz						
Outline	Drive Controller Part No.	Motor Power 208/230 V 50/60 Hz		Output Current	Max. Transient Current (60 s)	Total Dissipated Power
		kW	hp	A	A	W
1	ATV66U41M2	.75	1	4.0	11.7	125
		1.5	2	7.5	11.7	150
		2.2	3	10.6	11.7	181
2	ATV66U72M2	4.0	5	16.7	18.4	252
	ATV66U90M2	5.5	7.5	24.2	26.6	375
3	ATV66D12M2	7.5	10	30.8	33.9	459
	ATV66D16M2	11.0	15	46.2	50.8	619
4	ATV66D23M2	15.0	20	59.4	65.3	785
	ATV66D33M2	22.0	30	88.0	96.8	1127
5	ATV66D46M2	30.0	40	114	125	1332

Table 8: Recommended Braking Resistance Values

208/230 V Drive Controller Part No.	PA/PB Minimum Resistance Ω
ATV66U41M2	47
ATV66U72M2	18
ATV66U90M2	18
ATV66D12M2	12
ATV66D16M2	9
ATV66D23M2	6
ATV66D33M2	4.5
ATV66D46M2	3

Controller Specifications

Table 9: Specifications

Input voltage	400 V \pm 15% and 460 V \pm 15% or 208 V \pm 10% and 230 V \pm 15%
Displacement power factor	Approximately 0.96
Input frequency	47.5 to 63 Hz
Output voltage	Maximum voltage equal to input line voltage
Frequency resolution	Drive controller: Input AI1: (High Speed/1,024) Hz ^[1] Input AI2: (High Speed/512) Hz ^[1] Keypad display: 0.1 Hz increments Processor: 0.015 Hz increments With Option Board: Option board analog inputs: (High Speed/4096) Hz ^[1] Serial link: 0.015 Hz increments
Frequency accuracy	\pm (0.0075 Hz + 0.00005 times High Speed)
Temperature drift ^[2]	Drive controller: Analog inputs: 3×10^{-4} times High Speed/ $^{\circ}$ C typical Keypad display: 7×10^{-7} times High Speed/ $^{\circ}$ C maximum With option board: Option board analog inputs: 2.5×10^{-5} times High Speed/ $^{\circ}$ C typical Serial link: 7×10^{-7} times High Speed/ $^{\circ}$ C maximum
Frequency range	ATV66U41N4 to D79N4: 0.1 to 400 Hz (constant torque configuration) ATV66C10N4 to C31N41: 0.1 to 200 Hz (constant torque configuration) ATV66U41N4 to C31N41: 0.1 to 75/90 Hz (variable torque configuration) ATV66U41M2 to D46M2: 0.1 to 400 Hz (constant torque configuration) ATV66U41M2 to D46M2: 0.1 to 75/90 Hz (variable torque configuration)
Torque/over torque	See page 72.
Speed reference	AI1: 0-10 V AI2: 4-20 mA 0-5 V with switch on control board 0-20 mA, x-20 mA, 20-4 mA with keypad display
Speed regulation	Volts/Hertz control type: determined by motor slip, 3% typical for NEMA B motor Normal or high torque (sensorless flux vector) control type: 1.0% without adjustments 0.5% with optional tachometer
Efficiency	Typically greater than 96%
Reference sample time	10 ms
Ramps	Acceleration: 0.1 to 999.9 seconds Deceleration: 0.1 to 999.9 seconds
Braking to standstill	By DC injection: Automatic for 0.5 s if frequency drops below 1 Hz Manual by external signal
Dynamic braking	By optional resistor (see Dynamic Braking User's Manual) ^[3]

^[1] Resolution limited to processor resolution.

^[2] Drive Controller at operating load and temperature.

^[3] Refer to page 73.

Table 9: Specifications (Continued)

Drive controller protection	Against short circuits: <ul style="list-style-type: none"> • between output phases • between output phases and ground • on the outputs of internal supplies • on the logic and analog outputs Against input line supply under/overvoltage Against overheating: by thermal sensor								
Motor protection	Incorporated electronic thermal protection (page 70)								
Keypad display	<ul style="list-style-type: none"> • Self-diagnostics with full fault messages in six languages • Also refer to Level 1 & 2 Configuration manual 								
Communication	<ul style="list-style-type: none"> • Complete programming by keypad • Optional multidrop serial link (Modbus Plus, Modbus, Uni-Telway) 								
Temperature	Operation: +32 to +104 °F (0 to +40 °C) Storage: -13 to +158 °F (-25 to +70 °C)								
Humidity	95% maximum without condensation or dripping water								
Altitude	<ul style="list-style-type: none"> • ATV66U41N4/M2 through ATV66C19N4 ≤ 3,300 ft (1,000 m); above this de-rate by 1.2% for every 300 ft (100 m); max. 6,600 ft (2,000 m) • ATV66C23N41 through ATV66C31N41 ≤ 3,300 ft (1,000 m) 								
Enclosure	NEMA Type 1 (IP30)								
Pollution Degree	Pollution Degree 3 per NEMA ICS-1 and IEC 664-1.								
Resistance to vibration	Conforming to IEC 68-2-6: <ul style="list-style-type: none"> • ATV66U41N4 to D46N4 and ATV66U41M2 to D33M2: 1 mm peak to peak from 5 to 22.3 Hz and 2 g peak from 22.3 to 150 Hz • ATV66D54N4 to C31N41 and ATV66D46M2: 0.15 mm peak to peak from 10 to 58 Hz and 1 g peak from 58 to 150 Hz 								
Resistance to shock	Conforming to IEC 68-2-27: <ul style="list-style-type: none"> • 15 g peak for 11 ms 								
Codes and standards	UL Listed per UL 508C as incorporating electronic overload protection <table style="width: 100%; border: none;"> <tr> <td style="width: 60%;">ATV66U41N4 to D79N4 and ATV66U41M2 to D46M2</td> <td style="width: 40%;">UL File E164874 CCN NMMS</td> </tr> <tr> <td>ATV66C10N4 to C31N41 and ATV66U41M2 to D46M2</td> <td>UL File E138755 CCN NMMS</td> </tr> </table> CSA certified <table style="width: 100%; border: none;"> <tr> <td style="width: 60%;">ATV66U41N4 to D79N4</td> <td style="width: 40%;">CSA File LR96921 Class 3211-06</td> </tr> <tr> <td>ATV66C10N4 to C31N41</td> <td>CSA File LR 60905 Class 3211-06</td> </tr> </table> CE marked Conforms to applicable NEMA ICS, NFPA, IEC, and ISO 9001 standards	ATV66U41N4 to D79N4 and ATV66U41M2 to D46M2	UL File E164874 CCN NMMS	ATV66C10N4 to C31N41 and ATV66U41M2 to D46M2	UL File E138755 CCN NMMS	ATV66U41N4 to D79N4	CSA File LR96921 Class 3211-06	ATV66C10N4 to C31N41	CSA File LR 60905 Class 3211-06
ATV66U41N4 to D79N4 and ATV66U41M2 to D46M2	UL File E164874 CCN NMMS								
ATV66C10N4 to C31N41 and ATV66U41M2 to D46M2	UL File E138755 CCN NMMS								
ATV66U41N4 to D79N4	CSA File LR96921 Class 3211-06								
ATV66C10N4 to C31N41	CSA File LR 60905 Class 3211-06								

^[1] Resolution limited to processor resolution.

^[2] Drive Controller at operating load and temperature.

^[3] Refer to page 73.

DIMENSION & WEIGHTS FOR WALL OR PANEL MOUNTING
Conduit Entries - Bottom View

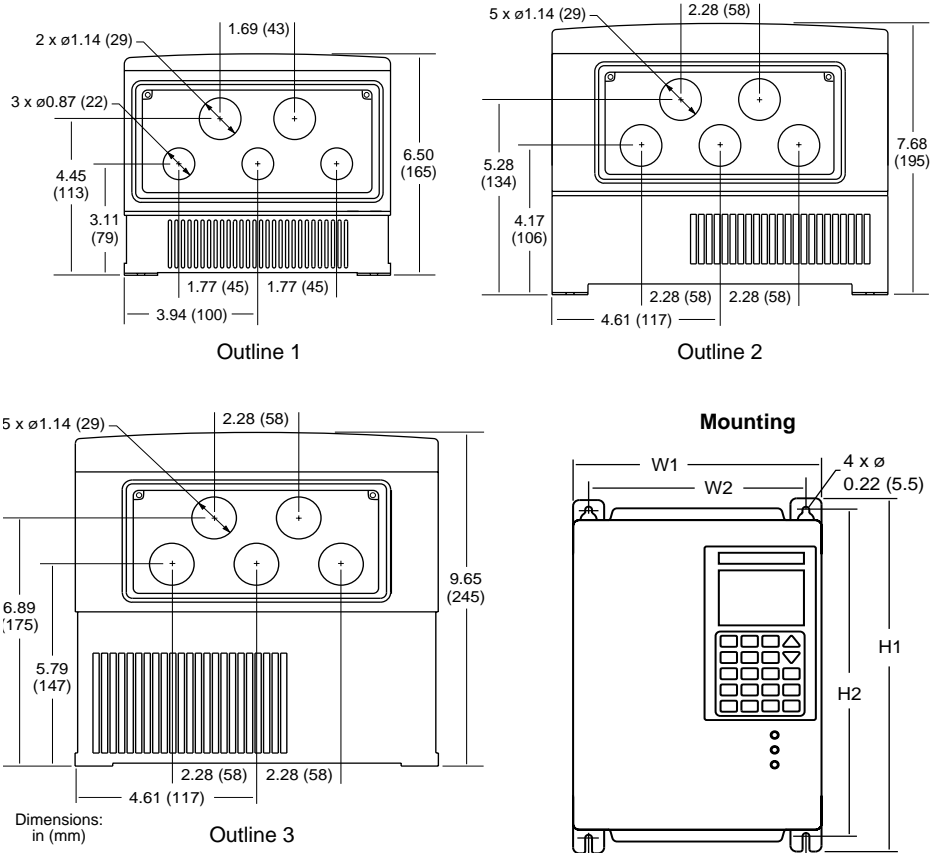

Mounting Dimensions

Outline	Drive Controller ATV66***N4	Drive Controller ATV66***M2	H1		H2		W1		W2		Ø		Weight		Door Swing Clearance ^[1]	
			in	mm	in	mm	in	mm	in	mm	in	mm	lb	kg	in	mm
1	U41 - U72	U41	11.6	295	10.9	280	7.8	200	6.9	175	0.22	5.5	10.4	4.7	7.8	200
2	U90, D12	U72, U90	12.8	325	12.2	310	9.2	234	8.2	209	0.22	5.5	16.1	7.3	9.2	234
3	D16, D23	D12, D16	16.3	415	15.7	400	9.2	234	8.2	209	0.22	5.5	30.9	14	9.2	234

^[1] Door hinges on left-hand side of drive controller.

Figure 7: Mounting Information for ATV66U41N4 to D23N4 and ATV66U41M2 to D16M2
NOTE: When metallic conduit is used with drive controllers of outlines 1-3, install a metal conduit entry plate (kit VY1A66201 – separately ordered). Kit mounts in place of the existing plastic plate and has a conduit hole pattern identical to those shown for outlines 1-3.

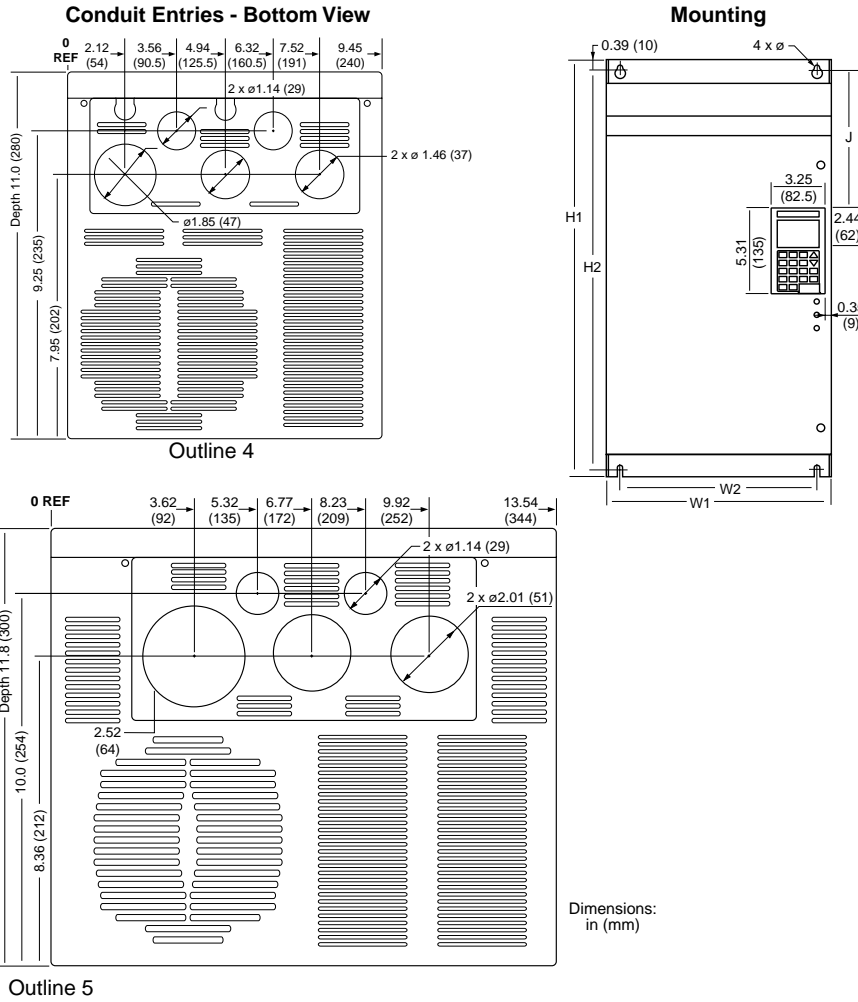

Mounting Dimensions

Outline	Drive Controller ATV66***N4	Drive Controller ATV66***M2	H1		H2		W1		W2		ϕ		J		Weight		Door Swing Clearance [1]	
			in	mm	in	mm	in	mm	in	mm	in	mm	in	mm	lb	kg	in	mm
4	D33, D46	D23, D33	23.6	600	22.8	580	9.5	240	8.1	205	0.28	7	3.19	81	59.5	27	9.5	240
5	D54 - D79	D46	25.6	650	24.4	620	13.8	350	11.8	300	0.35	9	3.39	86	88.2 90.4	40 41	13.8	350

[1] Door hinges on left-hand side of drive controller.

Figure 8: Mounting Information for ATV66D33N4 to D79N4 and ATV66D33M2 to D46M2

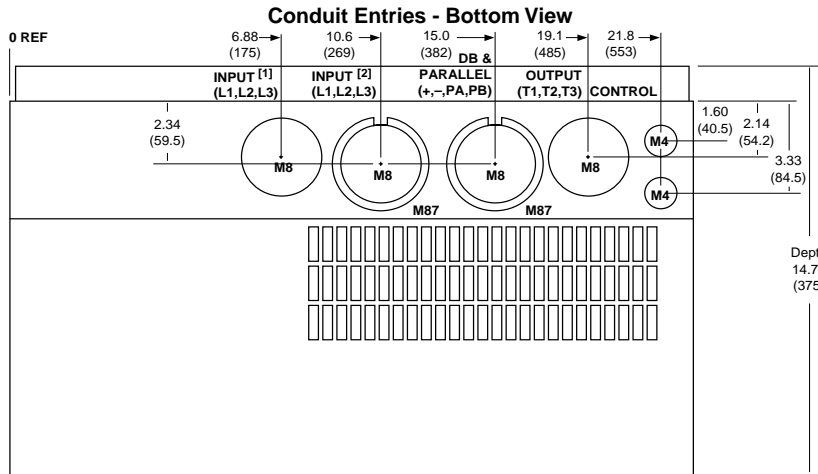

Outline 6

KNOCKOUTS:

- M4 = 2 x 1.00 (25.4) dia.
- M8 = 2.50 (63.5) dia.
- M87 = 3.00 (76.2) dia. w/ 2.50 (63.5) dia.

NOTES:

- [1] Use 2 in (50.8 mm) knockout for parallel cable runs.
- [2] Use single 3 in (76.2 mm) knockout for single cable run.
- [3] Leave an area extending 12 in (343 mm) below controller free of obstructions to allow access to ventilation fan.

Dimensions:
in (mm)

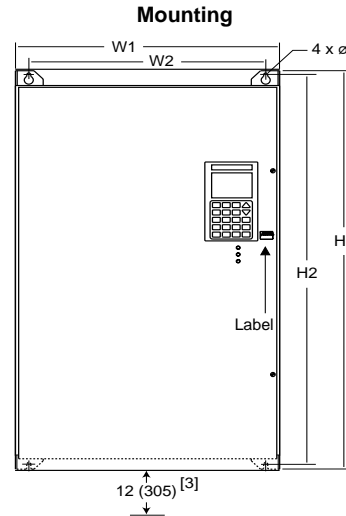

Mounting Dimensions

Outline	Drive Controller ATV66***N4	H1		H2		W1		W2		Ø		Weight		Door Swing Clearance ^[1]	
		in	mm	in	mm	in	mm	in	mm	in	mm	lb	kg	in	mm
6	C10	38.6	980	37.7	960	23.0	585	20.8	528	.375	9.5	280	127	23	584
	C13, C15, C19											300	136		

[1] Door hinges on left-hand side of drive controller.

Figure 9: Mounting Information for ATV66C10N4 to C19N4

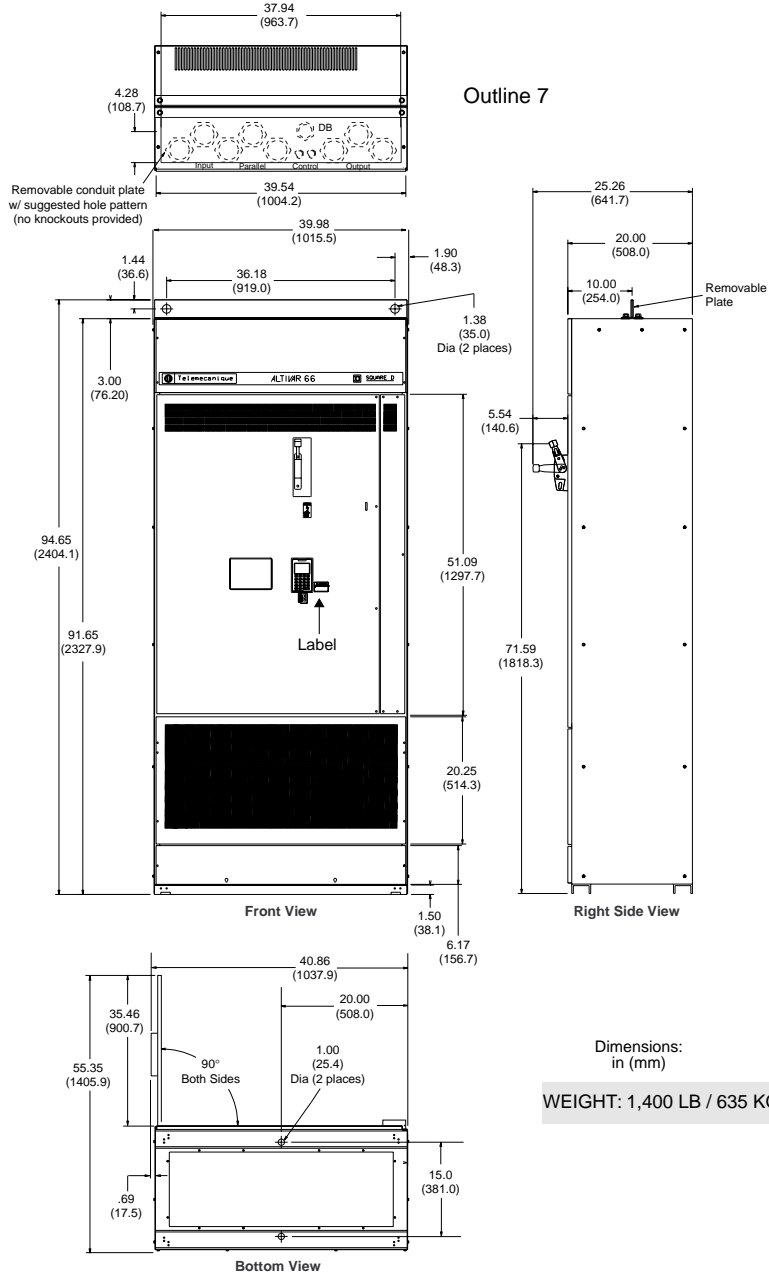

Figure 10: Mounting Information for ATV66C23N41 to C31N41

HANDLING DRIVE CONTROLLERS

It is recommended that the drive controller be kept in its factory carton during storage and transport to the installation site. The carton protects the drive controller and prevents damage to its exterior. Handle the drive controller carefully to avoid damage to the internal components, frame or exterior. When handling a drive controller, balance it carefully to keep it from tipping.

ATV66U41N4 through D46N4 and ATV66U41M2 through D33M2 drive controllers can be removed from their packing and installed manually.

After being removed from the carton or shipping wrap, ATV66D54N4 through C31N41 and ATV66D46M2 drive controllers require some type of mechanical lifting. Handle drive controllers:

- With a hoist, attaching a spreader bar to the two lifting rings on top of the drive controller (see Figure 11) or
- For ATV66D54N4 through C19N4 and ATV66D46M2, in a horizontal position, with back of drive controller resting on a pallet.

 WARNING
HANDLING AND LIFTING HAZARD
Keep area below any equipment being lifted clear of all personnel and property. Use lifting method shown below in Figure 11.
Failure to follow these instructions can result in death, serious injury, or equipment damage.

To hoist the drive controller, attach a spreader bar to the two lifting rings on top of the drive controller, as shown in Figure 11. Handle the drive controller carefully to avoid damage to the internal components, frame or exterior. Place the drive controller in an upright position.

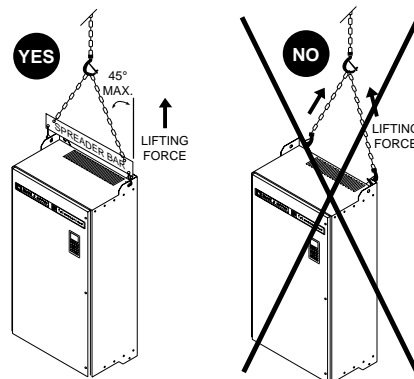

Figure 11: Hoisting ATV66D54N4 to C31N41 and ATV66D46M2

PRELIMINARY INSPECTION

The drive controller must be thoroughly inspected before storing or installing. Upon receipt:

1. Remove the drive controller from its packaging and visually inspect exterior for shipping damage.
2. Check that the drive controller catalog number agrees with the packing slip and corresponding purchase order. The catalog number appears on the drive controller nameplate and shipping package label. Refer to page 3 for location of drive controller nameplate.
3. If you find any shipping damage, notify the carrier and your sales representative.
4. If you will store drive controller after receipt, replace it in original packing material and observe storage temperature specifications on page 14.

Prior to installation:

1. Open the drive controller door or remove access covers.
2. Visually verify that all internal mounting hardware and terminal connection hardware is properly seated, securely fastened, and undamaged.
3. Visually verify that the control board is properly seated, securely fastened, and undamaged. Verify that internal wiring connections are tight. Inspect all connections for damage.
4. Close and secure the drive controller door or replace access covers.

 CAUTION
EQUIPMENT DAMAGE HAZARD
Do not operate or install any drive controller that appears damaged. Failure to follow this instruction can result in injury or equipment damage.

INSTALLATION PRECAUTIONS

To avoid equipment damage, follow these precautions when installing the drive controller:

- Electrical current through drive controller will result in heat losses that must be dissipated into the ambient air immediately surrounding the drive controller. To prevent thermal fault or equipment damage, provide sufficient enclosure cooling and/or ventilation to limit the ambient temperature around drive controller to a maximum of 40 °C. For power dissipation, refer to Tables 1 to 3 and Tables 5 to 7 on pages 6 - 12. Figure 12 on page 21 shows the minimum clearances required around the drive controller for

unobstructed air flow. For proper thermal dissipation, do not base the minimum enclosure size on clearances alone. Refer to section “Mounting in General-Purpose Metal Enclosure” on page 23 for additional information.

Dimensions: in (mm)

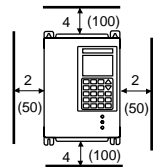

Outlines 1-3

(ATV66U41N4 to D23N4 and
ATV66U41M2 to D16M2)

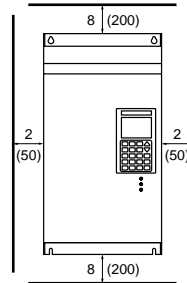

Outlines 4-5

(ATV66D33N4 to D79N4 and
ATV66D23M2 to D46M2)

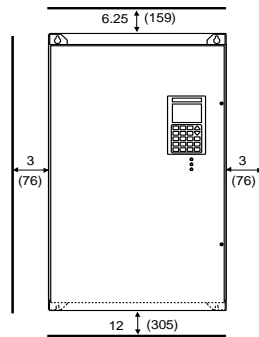

Outline 6

(ATV66C10N4 to C19N4)

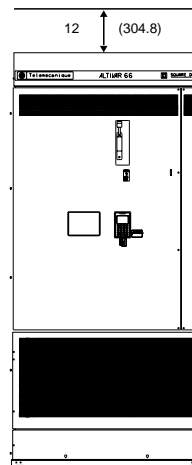

Outline 7

(ATV66C23N41 to C31N41)

Figure 12: Clearances for Drive Controllers

- Mount drive controller vertically.
- Do not locate drive controller near heat radiating elements.
- When installation surface is uneven, put a spacer behind the drive controller mounting pads to eliminate gaps. The drive controller exterior may be damaged if fastened to an uneven surface.

- Drive controllers are Type 1 enclosed devices and must be installed in a suitable environment. The environment around drive controller must not exceed Pollution Degree 3 requirements as defined in NEMA ICS 1 or IEC664.
- Verify that the voltage and frequency characteristics of the input line match the drive controller nameplate rating.
- Installation of a disconnect switch between the input line and drive controller is recommended. Follow national and local codes.
- Overcurrent protection is required. Install line power fuses (F1-F3) recommended in Tables 21 through 24, starting on page 59.
- Turn off all power before installing the drive controller. Place a “DO NOT TURN ON” label on the drive controller disconnect. Before proceeding with installation, lock the disconnect in the open position.
- The ATV66U41N4 to ATV66C19N4 and ATV66U41M2 to ATV66D46M2 drive controllers may be mounted inside another enclosure to increase the degree of protection or size of the enclosure. See “Mounting in General-Purpose Metal Enclosure” on page 23 or “Mounting in Type 12 (IP54) Metal Enclosure” on page 24.
- To improve ventilation, remove the front cover when mounting the drive controller in an enclosure. For ATV66U41N4 to D23N4 and ATV66U41M2 to ATV66D16M2 drive controllers, remove the front cover by first opening the cover, then separating the retaining clips on the cover from the side panel. For ATV66D33N4 to D79N4 and ATV66D23M2 to ATV66D46M2 drive controllers, remove the front cover by first opening the cover, then lifting it vertically. For ATV66C10N4 to C19N4 drive controllers, remove the front cover by removing the 3 hinge fastening bolts. For ATV66C23N41 to C31N41 drive controllers, there are no removable covers.
- With the front cover removed, the ATV66U41N4 to D79N4 and ATV66U41M2 to ATV66D46M2 drive controllers have an IP20 enclosure rating and the ATV66C10N4 to C19N4 drive controllers have an IP00 enclosure rating.
- For ATV66C10N4 to C31N41 drive controllers, the protective switch (see Figure 41 on page 86 and Figure 42 on page 87) may have tripped during transit. Reset before applying power (Breaker On/Start). Failure to validate may inhibit proper power up of the drive controller.
- The solid state switches of the drive controller power circuit do not provide complete isolation from the line. Leakage currents and voltages may be present at the U/T1, V/T2, and W/T3 terminals of the drive controller whenever power is present.

MOUNTING IN GENERAL-PURPOSE METAL ENCLOSURE

The ALTIVAR 66 drive controller is a Type 1/IP30 enclosed product. However, certain application considerations may require that the drive controller be installed inside a larger enclosure. If so, observe the following precautions:

Ventilation

Forced air cooling is provided on all drive controllers. A fan is located in the bottom of the drive controller (see Figure 13) and is protected by a perforated cover. The fan draws in ambient air from underneath or from the front of the enclosure over the heat sink fins, and expels it vertically from the top of the enclosure. When mounting the drive controller, be sure the air inlets and outlets are not obstructed.

- Follow the installation precautions on pages 20 through 22.
- Observe minimum clearance distances as indicated in Figure 12.
- If the enclosure does not provide sufficient free air flow, an enclosure ventilation fan is required to exhaust the heat to the enclosure outside ambient. The enclosure fan should have a greater fan flow rate than the drive controller fan flow rate listed in Table 10 on page 24.
- If there is a possibility of condensation, keep the control supply switched on during periods when the motor is not running or install thermostatically controlled strip heaters.

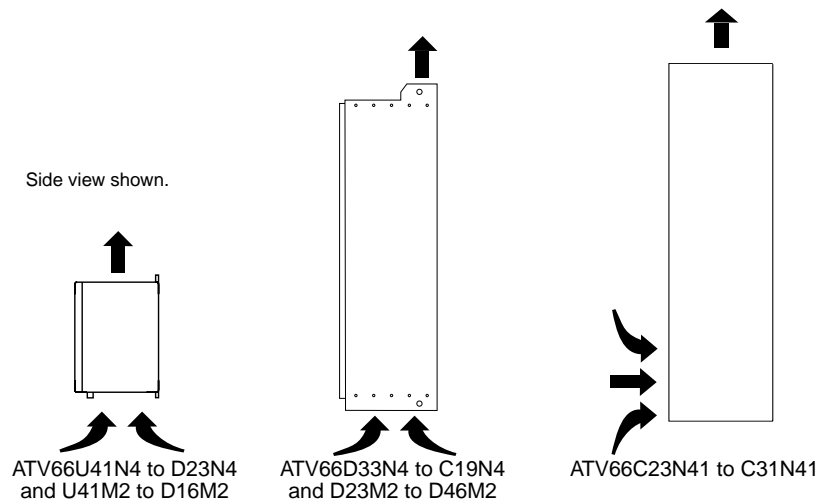

Figure 13: Ventilation for ATV66U41N4 to C31N41 and ATV66U41M2 to D46M2

Table 10: Flow Rates for ALTIVAR 66 Drive Controller Fans

Drive Controller	Fan Flow Rate ^[1]	
	CFM	dm ³ /s
ATV66U41N4, ATV66U54N4	10	5
ATV66U72N4, ATV66U41M2	20	10
ATV66U90N4, ATV66D12N4, ATV66U72M2, ATV66U90M2	44	22
ATV66D16N4, ATV66D23N4, ATV66D12M2, ATV66D16M2	94	47
ATV66D33N4, ATV66D46N4, ATV66D54N4, ATV66D64N4, ATV66D79N4, ATV66D23M2, ATV66D33M2, ATV66D46M2	200	100
ATV66C10N4, ATV66C13N4, ATV66C15N4, ATV66C19N4	500	250
ATV66C23N41, ATV66C28N41, ATV66C31N41	1000	500

^[1] Free air flow rates.

If an overtemperature condition occurs:

- The fault LED illuminates, and a fault message appears on the keypad display.
- The ventilation system continues operating if control supply is maintained, enabling the drive controller to cool rapidly.

For ATV66D16N4 to C31N41 and ATV66D12M2 to D46M2 drive controllers, the yellow pre-alarm LED flashes when the drive controller approaches the thermal limit. When the drive controller is running at rated load, and the thermal limit is reached, the drive controller will fault after a minimum one-minute pre-alarm warning.

Additional thermal protection of ATV66C10N4 - C31N41 drive controllers is provided. High-temperature switches are attached to the heat sink and other key components. When one of the switches opens, an immediate protective trip occurs.

MOUNTING IN TYPE 12 (IP54) METAL ENCLOSURE

Although the ALTIVAR 66 drive controller is a Type 1/IP30 enclosed product, certain applications may require Type 12 or IP54 protection. Two types of recess mounting kits are available for mounting drive controller with the heat sink outside the enclosure (see page 26).

Calculating Non-Ventilated Enclosure Size

Use the following equation to calculate R_{th} ($^{\circ}C/W$), the maximum allowable thermal resistance of the enclosure:

$$R_{th} = \frac{T_i - T_o}{P}$$

T_i = Max. internal ambient temp. (° C) around drive controller = 40 °C
 T_o = Max. external ambient temp. (° C) around enclosure
 P = Total power dissipated in enclosure (W)

For the power dissipated by the drive controllers at rated load, see Table 1 on page 6, Table 2 on page 8, Table 3 on page 9, Tables 5 and 6 on page 11, and Table 7 on page 12.

Useful heat exchange surface area, S (in²), of a wall-mounted enclosure generally consists of the sides, top, and front. Use the following equation to calculate the minimum surface area required for a drive controller enclosure:

$$S = \frac{K}{R_{th}}$$

R_{th} = Thermal resistance of the enclosure (calculated previously)
 K = Area resistivity of enclosure material (consult enclosure manufacturer)

Consider these points when sizing the enclosure:

- Use only metallic enclosures because they have good thermal conduction.
- Do not install enclosures where external heat sources (such as direct sunlight) can add to enclosure heat load. This procedure does not consider radiant or convected heat load from external sources.
- Consider the heat load of additional devices present inside the enclosure.
- Use a mounting method that allows air to move freely over all surfaces that are convection cooled. The actual useful area for convection cooling of the enclosure will vary depending upon the method of mounting.

The following example calculates enclosure size for an ATV66U72N4 (5 hp CT) drive controller mounted in a Type 12 enclosure.

- Maximum external temperature: $T_o = 25$ °C
- Power dissipated inside enclosure: $P = 185$ W (from Table 1)
- Maximum internal temperature: $T_i = 40$ °C
- Area resistivity for painted metal: $K = 300$
- Maximum allowable thermal resistance, R_{th} , calculated by formula:

$$R_{th} = \frac{40^\circ \text{C} - 25^\circ \text{C}}{185 \text{ W}} = 0.081 \text{ }^\circ\text{C/W}$$

- Minimum useful heat exchange surface area, S , calculated by formula:

$$S = \frac{300}{0.081} = 3700 \text{ in}^2$$

Useful heat exchange surface area (S) of the proposed wall-mounted enclosure:

- Height: 40 in (1016 mm)
- Width: 40 in (1016 mm)
- Depth: 20 in (508 mm)

$$\begin{array}{ccc} \text{front area} & \text{top area} & \text{side area} \\ \downarrow & \downarrow & \downarrow \\ S = (40 \times 40) + (20 \times 40) + 2(40 \times 20) = 4000 \text{ in}^2 \end{array}$$

If the selected enclosure does not provide the required surface area or does not meet application needs, consider the following:

- Use a larger enclosure.
- Use one of the recess mounting kits (ATV66U41N4 to D23N4 and ATV66U41M2 to D16M2 drive controllers). Refer to Table 11 on page 27.
- Add a passive heat exchanger to the enclosure.
- Add an air conditioning unit to the enclosure.
- Consult enclosure manufacturer.

Ventilation

When the drive controller is mounted inside a Type 12 or IP54 enclosure, observe the following ventilation precautions:

- Observe minimum clearance distances shown in Figure 12 on page 21.
- Follow the installation precautions on pages 20 through 22.
- Use a stirring fan, if necessary, to circulate the air inside the enclosure, prevent hot spots in the drive controller, and distribute the heat uniformly to convection-cooled surfaces.
- If there is a possibility of condensation, keep the control supply switched on during periods when the motor is not running or install thermostatically controlled strip heaters.

Recess Mounting

To reduce power dissipated in an enclosure, ATV66U41N4 to D23N4 and ATV66U41M2 to D16M2 drive controllers may be recess mounted in a wall of the enclosure, with the heat sink on the outside. Recess mounting requires a cutout in the enclosure and a recess mounting kit. Using this kit dissipates the majority of the drive controller heat load outside the enclosure.

The power dissipated in the enclosure (P_i) must be dissipated by the available surface area of the enclosure. The heat sink assembly, which is mounted

outside the enclosure, is rated for Type 12/IP54 protection when used with this kit.

There are two types of recess mounting kits: the Gasket Kit, which contains only the gasket necessary for recess mounting, and the Mounting Adaptor Plate Kit, which provides mounting plates along with gaskets. The gaskets in the Mounting Adaptor Plate Kit allow you to assemble the drive controller to the plates before bolting the assembly into the enclosure. This process aids in installation and maintenance of the drive controller.

Table 11: Recess Mounting Kits

Gasket Kit	Mounting Adaptor Plate Kit	Drive Controller	P _i [1] (W)
VW3-A66801T	VW3-A66806	ATV66U41N4 ATV66U54N4 ATV66U72N4 ATV66U41M2	70
VW3-A66802T	VW3-A66807	ATV66U90N4 ATV66D12N4 ATV66U72M2 ATV66U90M2	75
VW3-A66803T	VW3-A66808	ATV66D16N4 ATV66D23N4 ATV66D12M2 ATV66D16M2	110 130 110 130

[1] P_i = power dissipated in the enclosure by a recess-mounted drive controller.

CHAPTER 2—WIRING

WIRING	30
General Wiring Practices	30
Branch Circuit Connections	30
Control Wiring Precautions	38
Output Wiring Precautions	39
Grounding	40
TERMINAL STRIP LOCATIONS	41
POWER WIRING	44
CONTROL WIRING	46
ELECTROMAGNETIC COMPATIBILITY (EMC)	48
Installing the Ferrite Cores	49
USING THE LOGIC INPUTS (J12)	52
USING THE LOGIC OUTPUTS (J12)	53
USING THE SPEED REFERENCE INPUTS (J13)	54
USING THE ANALOG OUTPUTS (J13)	55
USING THE RELAY OUTPUTS (J1)	55
REMOVAL OF CL1, CL2 JUMPERS	56
CONTROL CIRCUIT DIAGRAMS	57
3-Wire Control	57
2-Wire Control	57
2-Wire Control with Isolation Contactor on Line Side (coast to stop)	58
EQUIPMENT RECOMMENDATIONS	59
Mounting and Replacing Line Power Fuses in ATV66C10N4 to C19N4 Drive Controllers	64
Replacing Line Power Fuses in ATV66C23N41 to C31N41 Drive Controllers	64

WIRING

General Wiring Practices

Good wiring practice requires the separation of control circuit wiring from all power (line and load) wiring. Power wiring to the motor must have the maximum possible separation from all other power wiring, whether from the same drive or other drives. **Do not run in the same conduit**; this separation reduces the possibility of coupling electrical noise between circuits.

When wiring ALTIVAR® 66 drive controllers, follow the wiring practices required by national and local electrical codes in addition to the following:

- When using metallic conduit with ATV66U41N4 to D23N4 and ATV66U41M2 to D16M2 drive controllers, you must also use a metal conduit entry plate, kit VY1A66201. This kit mounts in place of the existing plastic plate and is held in place with two screws. A bond wire, which must be connected to ground (GND) on the J2 terminal strip, is included.
- Use metallic conduit for all drive controller wiring. Do not run control and power wiring in the same conduit.
- Separate metallic conduits carrying power wiring or low-level control wiring by at least 3 in (8 cm).
- Separate non-metallic conduits or cable trays used to carry power wiring from metallic conduit carrying low-level control wiring by at least 12 in (30.5 cm).
- Cross the metallic conduits and non-metallic conduits at right angles whenever power and control wiring cross.
- Attenuate conducted emissions to the line from the drive controller in some installations to prevent interference with telecommunication, radio, and sensitive electronic equipment. Such instances may require attenuating filters. Consult catalog for selection and application of these filters.

Branch Circuit Connections

WARNING

OVERCURRENT PROTECTIVE DEVICES MUST BE PROPERLY COORDINATED

- To achieve published fault withstand current ratings, install the specified fuses listed on the drive controller nameplate and in Tables 21 through 25.
- Do not connect drive controller to power feeder whose short circuit capacity exceeds drive controller withstand fault rating listed on drive controller nameplate.

Failure to follow these instructions can result in death, serious injury, or equipment damage.

All ALTIVAR 66 drive controllers require fuse protection. ATV66U41N4 to D79N4 and ATV66U41M2 to D46M2 drive controllers require user-supplied external fuses as indicated on the nameplate; in Table 21 on page 59; and in

Table 24 on page 62. ATV66C10N4 to C19N4 drive controllers have provisions for mounting the user-supplied fuses internally (refer to the controller nameplate or Table 22 on page 60 for recommended fuses). ATV66C23N41 to C31N41 drive controllers are shipped with fuses. See page 64 for information on mounting and replacing fuses in ATV66C10N4 to ATV66C31N41 drive controllers.

Refer to NEC Article 430 for sizing branch circuit conductors.

All branch circuit components and equipment (such as transformers, feeder cables, disconnect devices, and protective devices) must be rated for the input current of the ALTIVAR 66 drive controller, not the motor full load current. The input current of the controller depends on impedance of the power distribution system and available fault current at the drive input terminals. The controller input current is stamped on the nameplate (see Figures 3 - 6 for nameplate location).

Select the input current corresponding to the available fault current capability or the line impedance present. If the branch circuit available fault current capability is limited by fuses or circuit breakers (not system impedance), use the available fault current capability on the line side of the fuses or circuit breakers to select the drive controller input current. Tables 12 - 17 provide input current information to optimally size branch circuit conductors.

Line reactors can be used to add reactance to the branch circuit. Line reactors are not recommended if the branch circuit inductance (as shown in the heading of Tables 12 - 17 for each AIC rating) exceeds 100% of the inductance value calculated for a 3% line impedance or exceeds 20% of the inductance value calculated for a 5% line impedance. Excessive impedance may shift input voltage out of the tolerance of the drive controller rating. Line reactors can be used to minimize drive controller input line current, and reduce controller nuisance tripping due to transient overvoltage. If line reactors are used:

- the input conductor ampacity rating should not be less than the ampacity rating selected, based on the rated controller output current.
- in systems that use bypass contactors, the line reactor should always be connected between the L1, L2, and L3 terminals on the controller and the line fuses. A line reactor in a bypass motor starting circuit will reduce the ability of the motor to produce starting torque.
- the voltage tolerance at input of the reactor will be different from that of the drive controller due to the voltage drop across the line reactor. Voltage tolerance measured at input terminals of the drive controller will be as specified in this manual.
- the line reactor can also improve a phase-to-phase voltage imbalance.

The input line current ratings listed in Tables 12 - 17 for 3% and 5% line reactance are based on coordinated ratings. To calculate the necessary

minimum line reactance, use the following formula to verify the selection of the minimum reactor impedance needed for installation:

$$L = \frac{V_{L-L} \times \%Z \times 10}{I_{fund} \times \sqrt{3} \times 2\pi \times f}$$

L = inductance, in millihenries (mH)
 V_{L-L} = input voltage measured line to line (utilization voltage)
 $\%Z$ = desired input impedance rating in percent
 I_{fund} = drive controller output current rating
 π = Pi constant (3.14)
 f = fundamental line frequency (50 or 60 Hz)

Example:

User has a 7.5 hp, 11 A at 460 V/60 Hz motor in combination with ATV66U90N4U (7.5 hp @ 460 V, 11 FLA) drive controller. Calculate the minimum line reactance of a nominal 3% reactor:

V_{L-L} = 460 V (utilization voltage)
 $\%Z$ = 3 (3% rated line reactor)
 I_{fund} = 11 A (controller rated output)
 f = 60 Hz (fundamental line frequency)

$$L = \frac{460 \text{ V} \times 3 \times 10}{11 \text{ A} \times \sqrt{3} \times 2\pi \times 60 \text{ Hz}} = 1.9213 \text{ mH}$$

Select a line reactor that has a minimum inductance rating (per phase) greater than or equal to 1.9213 mH. None of the branch circuit inductance values of Tables 12 - 14 exceed 1.9 mH.

Table 12: Input Line Currents for Selecting Branch Circuit Conductors, 460 V CT
Note: The input conductor ampacity rating should not be less than the ampacity rating selected, based on the rated controller output current.

Motor Power		Drive Controller	Output Current	Input Line Current			With Line Impedance of	
kW 400V 50 Hz	hp 460V 60 Hz			5,000 AIC 0.141 mH 10,000 AIC [1] 0.070 mH 18,000 AIC [2] 0.039 mH	22,000 AIC 0.032 mH	65,000 AIC 0.011 mH	3%	5%
		A		A	A	A	A	A
0.75	—	ATV66U41N4	2.3	—	4.0	—	—	—
—	1		1.8	2.7	3.2	3.5	1.6	1.5
1.5	—		4.1	—	3.5	—	—	—
—	2		3.4	4.7	5.7	6.4	3.0	2.7
2.2	—		5.8	—	9.0	—	—	—
—	3	4.8	6.5	8.0	8.8	4.2	3.9	
3	—	ATV66U54N4	7.8	—	12	—	—	—
4	—	ATV66U72N4	10.5	—	15.0	—	—	—
—	5		7.6	9.8	11.9	13.2	6.7	6.2
5.5	—	ATV66U90N4	13	—	20.0	—	—	—
—	7.5		11	13.9	16.7	18.5	10.0	9.2
7.5	—	ATV66D12N4	17.6	—	26.0	—	—	—
—	10		14.0	17.6	21.4	24.7	13.0	12.0

[1] 10,000 AIC denoted by asterisk (*).

[2] 18,000 AIC denoted by (t).

Table 12: Input Line Currents for Selecting Branch Circuit Conductors, 460 V CT (Continued)
Note: The input conductor ampacity rating should not be less than the ampacity rating selected, based on the rated controller output current.

Motor Power		Drive Controller	Output Current	Input Line Current			With Line Impedance of	
				5,000 AIC 0.141 mH 10,000 AIC ^[1] 0.070 mH 18,000 AIC ^[2] 0.039 mH	22,000 AIC 0.032 mH	65,000 AIC 0.011 mH	3%	5%
kW 400V 50 Hz	hp 460V 60 Hz		A	A	A	A	A	A
11 —	— 15	ATV66D16N4	24.2 21.0	— 24.8	35.0 29.9	— 33.6	— 19.4	— 17.9
15 —	— 20	ATV66D23N4	33.0 27.0	— 31.9	45.0 38.7	— 44.8	— 26.0	— 23.6
22 —	— 30	ATV66D33N4	48.4 40.0	— 44.0	60.0 52.4	— 59.7	— 37.0	— 34.2
30 —	— 40	ATV66D46N4	66.0 52.0	— 57.1	78.0 67.6	— 76.6	— 49.0	— 45.6
37 —	— 50	ATV66D54N4	79.2 65.0	— 68.3	94.0 80.8	— 91.9	— 61.2	— 56.3
45 —	— 60	ATV66D64N4	93.5 77.0	— 86.4*	110 94.6	— 108	— 71.6	— 66.7
55 —	— 75	ATV66D79N4	115.5 96.0	— 106*	130 116	— 133	— 90.1	— 83.5
75 —	— 100	ATV66C10N4	157 124	— 138*	171 151	— 173	— 121	— 113
90 —	— 125	ATV66C13N4	190 156	— 166*	198 186	— 211	— 153	— 143
110 —	— 150	ATV66C15N4	226 180	— 191*	237 217	— 246	— 182	— 170
132 —	— 200	ATV66C19N4	270 240	— 242*	275 277	— 314	— 238	— 223
160 —	— 250	ATV66C23N41	330 300	— 318†	326 333	— 379	— 295	— 276
200 —	— 300	ATV66C28N41	407 360	— 366†	399 379	— 441	— 352	— 328
220 —	— 350	ATV66C31N41	449 420	— 419†	421 431	— 506	— 410	— 383

^[1] 10,000 AIC denoted by asterisk (*).

^[2] 18,000 AIC denoted by (†).

Table 13: Input Line Currents for Selecting Branch Circuit Conductors, 460 V VT
Note: The input conductor ampacity rating should not be less than the ampacity rating selected, based on the rated controller output current.

Motor Power		Drive Controller	Output Current	Input Line Current			With Line Impedance of	
kW 400V 50 Hz	hp 460V 60 Hz			5,000 AIC 0.141 mH 10,000 AIC [1] 0.070 mH 18,000 AIC [2] 0.039 mH	22,000AIC 0.032 mH	65,000 AIC 0.011 mH	3%	5%
			A	A	A	A	A	A
0.75	—	ATV66U41N4	2.0	—	4.0	—	—	—
—	1		1.8	2.7	3.2	3.5	1.6	1.5
1.5	—		3.7	—	6.5	—	—	—
—	2		3.4	4.7	5.7	6.4	3.0	2.7
2.2	—		5.3	—	9.0	—	—	—
—	3		4.8	6.5	8.0	8.8	4.2	3.9
3	—		7.1	—	12.0	—	—	—
4	—	ATV66U54N4	9.5	—	16.0	—	—	—
—	5		7.6	9.8	11.9	13.2	6.7	6.2
5.5	—	ATV66U72N4	11.8	—	20.0	—	—	—
—	7.5		11.0	14.0	17.0	18.4	10.0	9.2
7.5	—	ATV66U90N4	16.0	—	25.0	—	—	—
—	10		14.0	17.7	21.4	23.4	13.0	12.0
11	—	ATV66D12N4	22.0	—	36.0	—	—	—
—	15		21.0	25.1	30.6	35.3	19.4	17.9
15	—	ATV66D16N4	30.0	—	45.0	—	—	—
—	20		27.0	31.8	38.3	42.9	26.0	23.6
18.5	—	ATV66D23N4	37.0	—	57.0	—	—	—
—	25		34.0	38.7	47.0	54.6	31.1	30.1
30	—	ATV66D33N4	60.0	—	79.0	—	—	—
—	40		52.0	57.1	67.6	76.6	49.0	45.6
37	—	ATV66D46N4	72.0	—	94.0	—	—	—
—	50		65.0	68.6	81.2	91.9	61.2	56.3
45	—	ATV66D54N4	85.0	—	112	—	—	—
—	60		77.0	86.4*	94.6	108	71.6	66.7
55	—	ATV66D64N4	105	—	130	—	—	—
—	75		96.0	106*	116	133	90.1	83.5
75	—	ATV66D79N4	143	—	176	—	—	—
—	100		124	138*	150	171	121	113
90	—	ATV66C10N4	190	—	199	—	—	—
—	125		156	165*	185	210	153	143

[1] 10,000 AIC denoted by asterisk (*).

[2] 18,000 AIC denoted by (t).

Table 13: Input Line Currents for Selecting Branch Circuit Conductors, 460 V VT
Note: The input conductor ampacity rating should not be less than the ampacity rating selected, based on the rated controller output current.

Motor Power		Drive Controller	Output Current A	Input Line Current			With Line Impedance of	
kW 400V 50 Hz	hp 460V 60 Hz			5,000 AIC 0.141 mH 10,000 AIC [1] 0.070 mH 18,000 AIC [2] 0.039 mH A	22,000AIC 0.032 mH A	65,000 AIC 0.011 mH A	3% A	5% A
110 —	— 150	ATV66C13N4	226 180	— 191*	238 217	— 246	— 182	— 170
132 —	— 200	ATV66C15N4	270 240	— 242*	278 277	— 314	— 238	— 223
160	—	ATV66C19	330	—	336	—	—	—
160 — 200 —	— 250 — 300	ATV66C23N41	330 300 407 360	— 317† — 367†	336 333 399 381	— 379 — 443	— 295 — 352	— 276 — 328
220 —	— 350	ATV66C28N41	449 420	— 419†	428 431	— 506	— 410	— 383
250 —	— 400	ATV66C31N41	460 477	— 472†	472 484	— 571	— 467	— 438

[1] 10,000 AIC denoted by asterisk (*).

[2] 18,000 AIC denoted by (†).

Table 14: Input Line Currents for Selecting Branch Circuit Conductors, 460 V VTLN
Note: The input conductor ampacity rating should not be less than the ampacity rating selected, based on the rated controller output current.

Motor Power		Drive Controller	Output Current	Input Line Current			With Line Impedance of	
kW 400 V 50 Hz	hp 460 V 60 Hz			5,000 AIC 0.141 mH 10,000 AIC [1] 0.070 mH	22,000 AIC 0.032 mH	65,000 AIC 0.011 mH	3%	5%
			A	A	A	A	A	A
0.75	—	ATV66U41N4	2.0	—	4.0	—	—	—
—	1		1.8	2.7	3.2	3.5	1.6	1.5
1.5	—		3.7	—	6.5	—	—	—
—	2		3.4	4.7	5.7	6.4	3.0	2.7
2.2	—		5.3	—	9.0	—	—	—
—	3	4.8	6.5	8.0	8.8	4.2	3.9	
3	—	ATV66U54N4	7.1	—	12.0	—	—	—
4	—	ATV66U72N4	9.5	—	15.0	—	—	—
—	5		7.6	9.8	11.9	13.2	6.7	6.2
5.5	—	ATV66U90N4	11.8	—	20.0	—	—	—
—	7.5		11.0	13.9	16.7	18.5	10.0	9.2
7.5	—	ATV66D12N4	16.0	—	26.0	—	—	—
—	10		14.0	17.6	21.4	24.7	13.0	12.0
11	—	ATV66D16N4	22	—	35.0	—	—	—
—	15		21	24.8	29.9	33.6	19.4	17.9
15	—	ATV66D23N4	30	—	45.0	—	—	—
—	20		27	31.9	38.7	44.8	26.0	23.6
22	—	ATV66D33N4	44	—	60.0	—	—	—
—	30		40	44.0	52.4	59.7	37.0	34.2
30	—	ATV66D46N4	60	—	78.0	—	—	—
—	40		52	57.1	67.6	76.6	49.0	45.6
37	—	ATV66D54N4	72	—	94.0	—	—	—
—	50		65	68.3	80.8	91.9	61.2	56.3
45	—	ATV66D64N4	85	—	110	—	—	—
—	60		77	86.4*	94.6	108	71.6	66.7
55	—	ATV66D79N4	105	—	130	—	—	—
—	75		96	106*	116	133	90.1	83.5

[1] 10,000 AIC denoted by asterisk (*).

Table 15: Input Line Currents for Selecting Branch Circuit Conductors, 208-230 V CT
Note: The input conductor ampacity rating should not be less than the ampacity rating selected, based on the rated controller output current.

Motor Power 208/230 V 50/60 Hz		Drive Controller	Output Current A	Input Line Current							
				208 V 8,800 AIC 0.036 mH A	230 V			With Line Impedance of			
					5,000 AIC 0.070 mH A	22,000 AIC 0.016 mH A	208 V		230 V		
kW	hp						3% A	5% A	3% A	5% A	
0.75	1	ATV66U41M2	4.0	5.7	4.8	5.7	3.5	3.3	3.5	3.0	
1.5	2		7.5	10.1	8.6	10.2	6.4	6.2	6.0	5.6	
2.2	3		10.6	14.1	11.9	14.1	9.2	8.9	8.5	8.1	
4	5	ATV66U72M2	16.7	21.4	18.0	21.5	14.7	14.3	14.0	12.9	
5.5	7.5	ATV66U90M2	24.2	30.4	25.6	30.5	22.0	21.3	20.1	19.3	
7.5	10	ATV66D12M2	30.8	38.6	32.6	38.7	29.0	27.8	26.5	25.2	
11	15	ATV66D16M2	46.2	54.7	46.2	54.8	43.0	41.1	38.7	37.2	
15	20	ATV66D23M2	59.4	69.4	58.8	69.5	57.0	54.1	50.4	49.0	
20	30	ATV66D33M2	88.0	97.6	81.1	97.6	83.0	79.8	74.0	72.0	
30	40	ATV66D46M2	114	124.2	102.1	125.4	109.1	105.4	98.7	95.6	

Table 16: Input Line Currents for Selecting Branch Circuit Conductors, 208/230 V VT
Note: The input conductor ampacity rating should not be less than the ampacity rating selected, based on the rated controller output current.

Motor Power 208/230 V 50/60 Hz		Drive Controller	Output Current A	Input Line Current							
				208 V 8,800 AIC 0.036 mH A	230 V			With Line Impedance of			
					5,000 AIC 0.070 mH A	22,000 AIC 0.016 mH A	208 V		230 V		
kW	hp						3% A	5% A	3% A	5% A	
0.75	1	ATV66U41M2	4.0	5.7	4.9	5.8	3.5	3.3	3.5	3.0	
1.5	2		7.5	10.2	8.6	10.2	6.4	6.2	6.0	5.6	
2.2	3		10.6	14.0	11.8	14.0	9.2	8.9	8.5	8.1	
5.5	7.5	ATV66U72M2	24.2	30.6	25.8	30.6	22.0	21.3	20.1	19.3	
7.5	10	ATV66U90M2	30.8	38.8	32.7	38.8	29.0	27.8	26.5	25.2	
11	15	ATV66D12M2	46.2	54.7	46.2	54.8	43.0	41.1	38.7	37.2	
15	20	ATV66D23M2	59.4	69.3	58.7	69.4	57.0	54.1	50.4	49.0	
18.5	25		74.8	84.4	71.5	84.4	69.2	67.2	64.0	60.9	
30	40	ATV66D33M2	114	124.9	102.7	125.9	109.1	105.4	98.7	95.6	
37	50	ATV66D46M2	143	149.3	122.6	151.1	134.0	129.6	121.0	117.4	

Table 17: Input Line Currents for Selecting Branch Circuit Conductors, 208/230 V VTLN
Note: The input conductor ampacity rating should not be less than the ampacity rating selected, based on the rated controller output current.

Motor Power 208/230 V 50/60 Hz		Drive Controller	Output Current A	Input Line Current							
				208 V 8,800 AIC 0.036 mH A	230 V			With Line Impedance of			
					5,000 AIC 0.070 mH A	22,000 AIC 0.016 mH A	208 V		230 V		
kW	hp						3%	5%	3%	5%	
							A	A	A	A	
0.75	1	ATV66U41M2	4.0	5.8	5.4	6.4	3.5	3.3	3.5	3.0	
1.5	2		7.5	10.4	8.8	10.4	6.4	6.2	6.0	5.6	
2.2	3		10.6	14.3	12.0	14.3	9.2	8.9	8.5	8.1	
4	5	ATV66U72M2	16.7	21.8	18.3	21.8	14.7	14.3	14.0	12.9	
5.5	7.5	ATV66U90M2	24.2	30.6	25.8	30.7	22.0	21.3	20.1	19.3	
7.5	10	ATV66D12M2	30.8	38.9	32.8	39.0	29.0	27.8	26.5	25.2	
11	15	ATV66D16M2	46.2	55.1	46.5	55.2	43.0	41.1	38.7	37.2	
15	20	ATV66D23M2	59.4	70.3	59.6	70.3	57.0	54.1	50.4	49.0	
22	30	ATV66D33M2	88.0	97.2	80.8	97.2	83.0	79.8	74.0	72.0	
30	40	ATV66D46M2	114	124.2	102.0	125.4	109.1	105.4	98.7	95.6	

Control Wiring Precautions

Although all control inputs and outputs of the drive controller are isolated from the input lines, you must follow certain control wiring precautions:

- Keep control wiring conductor runs short and direct. Follow the conduit and circuit separation requirements listed throughout this section.
- Make sure that the control contacts used with the drive controller inputs are rated for operation at open circuit voltages of 24 VDC and closed circuit currents of 10 mADC.
- Analog inputs and outputs require twisted cable with a pitch of 1 to 2 inches. Use of a cable shield is recommended. The shield must be terminated to ground at one end only. It is recommended that the shield be terminated at the drive controller. Shield connection terminals are provided on the ALTIVAR 66 drive controller for this purpose.
- Make sure that the coils of all relays and solenoids connected to the output contacts of the drive controller are equipped with appropriate transient suppressors.
- For proper control wiring, route conductors to avoid contact with other voltage potentials in the drive controller. Wire insulation must have the appropriate voltage rating for the voltage present. The ATV66C10N4 to C31N41 drive controllers are equipped with control wiring channels to

allow routing of control conductors away from power circuit conductors. The channels are located on the right side of ATV66C10N4 to C19N4 controllers, and on the left side of ATV66C23N41 to C31N41 controllers.

Output Wiring Precautions

WARNING

DRIVE CONTROLLER DAMAGE

Drive controller will be damaged if input line voltage is applied to output terminals (U/T1, V/T2, W/T3). Check power connections before energizing drive controller.

Failure to follow these instructions can result in death, serious injury, or equipment damage.

The drive controller is sensitive to the amount of capacitance (either phase-to-phase or phase-to-ground) present on the output power conductors. If excessive capacitance is present, the drive controller may trip. Follow the guidelines below when selecting output cable:

- Cable type: the cable selected must have a low capacitance phase-to-phase and to ground. Do not use mineral impregnated cable because it has a very high capacitance. Immersion of cables in water increases capacitance.
- Cable length: the longer the cable, the greater the capacitance. Cable lengths greater than 320 ft (100 m) may require analysis to determine if mitigation is required. Contact your local ALTIVAR representative.
- Proximity to output cables from other drive controllers: because of the high frequency switching and increased capacitance, the drive may fault under some conditions.
- Do not use lightning arrestors or power factor correction capacitors on output of drive controller.

For installation where cable capacitances may be a problem, an inductor can be installed between the drive controller and the motor. See catalog or consult factory for additional information.

CAUTION

DRIVE CONTROLLER SWITCH FAILURE

For proper drive controller electronic short circuit protection, inductance is required in the output power wiring. Provide at least 48 in (122 cm) of cable at the drive controller output (U/T1, V/T2, W/T3).

Failure to follow these instructions can result in equipment damage.

Grounding

For safe, dependable operation, drive controllers must be grounded according to all national and local codes. To ground the drive controller:

- Connect a copper wire from the grounding terminal to the power system ground conductor. Wire size is determined by the drive controller size and by national and local codes.
- Verify that resistance to ground is one ohm or less. Improper grounding causes intermittent and unreliable operation.

⚠ DANGER

HAZARDOUS VOLTAGE - INADEQUATE GROUNDING

- Ground equipment using screw provided. Drive controller must be properly grounded before applying power.
- Do not use metallic conduits or shields as a ground conductor.

Failure to follow these instructions will result in death or serious injury.

Multiple drive controllers must be grounded shown in Figure 14. Do not loop or series the ground cables.

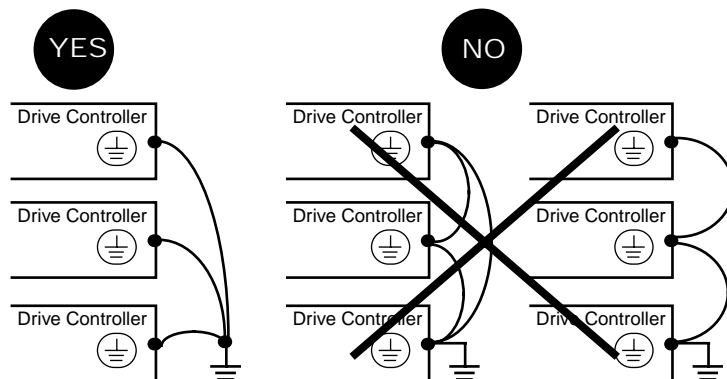

Figure 14: Grounding Multiple Drive Controllers

- When using the metal conduit entry plate (kit VY1A66201) with ATV66U41N4 to D23N4 and ATV66U41M2 to D16M2 drive controllers, the bond wire must be connected to ground (GND) as shown in Figure 15 on page 41 and Figure 16 on page 42.

TERMINAL STRIP LOCATIONS

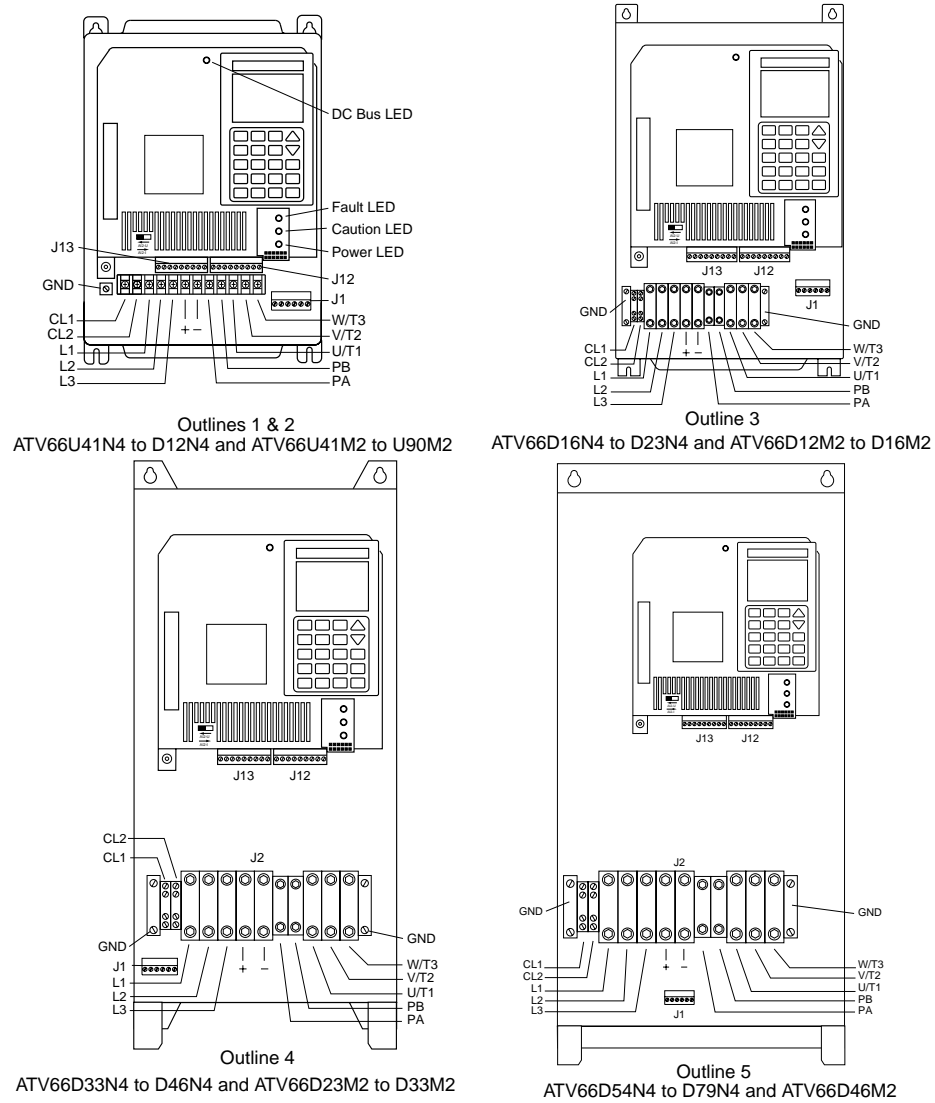
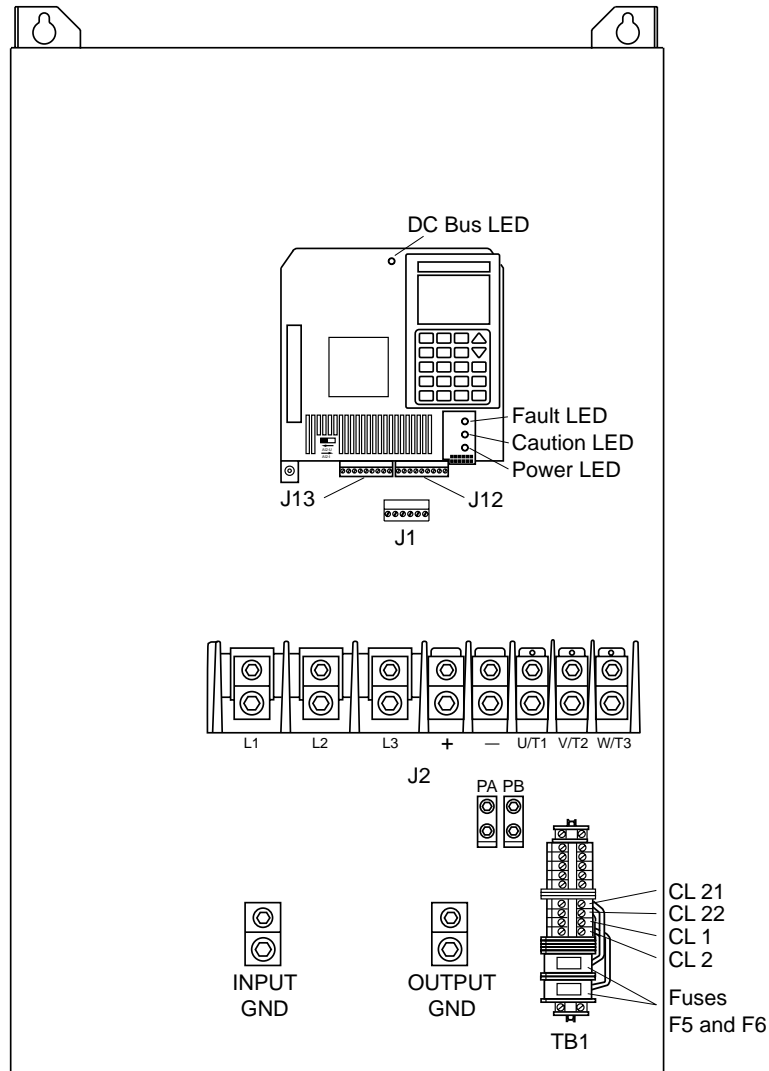

Figure 15: Terminal Strip Locations: ATV66U41N4 to D79N4 and ATV66U41M2 to D46M2

Outline 7



Outline 6

Figure 16: Terminal Strip Locations: ATV66C10N4 to C19N4

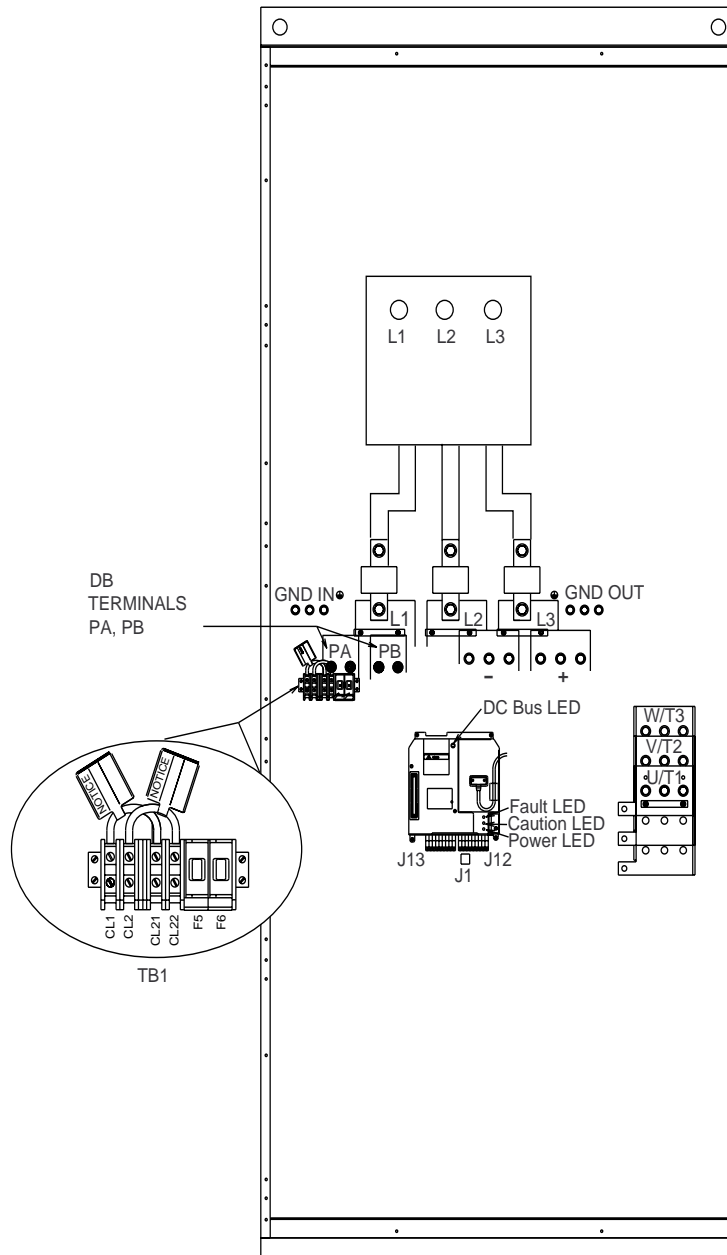

Figure 17: Terminal Strip Locations: ATV66C23N41 to C31N41

POWER WIRING

Table 18: Power Terminal Strip Characteristics [1]

Connector	Terminal [2]	Function	Characteristics
J2	GND L1 L2 L3	3-phase power supply	400/460 VAC $\pm 15\%$ (ATV66•••N4 units) 208 V $\pm 10\%$ / 230 V $\pm 15\%$ (ATV66•••M2 units) 47 to 63 Hz
	+ –	Filtered DC voltage	550 to 850 VDC (ATV66•••N4 units) 275 to 425 VDC (ATV66•••M2 units)
	U/T1 V/T2 W/T3 GND	Output connections to motor	0 to 400 VAC / 0 to 460 VAC 0 to 208 VAC / 0 to 230 VAC
	PA PB	Dynamic braking resistor	550 to 850 VDC (ATV66•••N4 units) 275 to 425 VDC (ATV66•••M2 units)
	CL1[3, 4] CL2	Single-phase control supply	400/460 VAC $\pm 15\%$ (ATV66•••N4 units) 208 V $\pm 10\%$ / 230 V $\pm 15\%$ (ATV66•••M2 units) 47 to 63 Hz
	CL21[4] CL22	Tap for CL1 and CL2	ATV66C10N4 to C31N41 drive controllers only

[1] For power terminal strip locations, refer to Figures 15 to 17 on pages 41 to 43. Drive controllers ATV66C23N41 to C31N41 do not have a J2 terminal block. See Figure 17 for the location of each individual terminal.

[2] See circuit diagrams on page 57 and 58.

[3] The CL1 and CL2 terminals are connected with jumpers to L1 and L2 power supply. When using a line contactor, the jumpers must be removed and CL1 and CL2 supplied separately to maintain control power. See circuit diagrams on page 57 and page 58. CL1 and CL2 must be connected to the same feeder conductors that supply L1, L2 and L3 of the drive controller.

[4] Terminals are located on TB1 for ATV66C10N4 to C31N41.

Table 19: Power Terminal Wire Range

NOTE: All wire entries in AWG or Thousand Circular Mills (MCM) represent the maximum allowable conductor size for the referenced field wiring terminal. All wire entries in square mm (mm²) represent the recommended size of conductor based on IEC 364 conductor dimensioning criteria. Do not use the IEC 364 conductor selections for installations requiring dimensioning per NFPA 70 or CSA C22.

Terminals			Drive Controller (ATV66****)							
			U41N4 U54N4 U72N4 U41M2 [1]	U90N4 D12N4 U72M2U 90M2 [1]	D16N4 D23N4 D12M2 D16M2 [1]	D33N4 D46N4 D23M2 D33M2 [2]	D54N4 D64N4 D79N4 D46M2 [2]	C10N4 C13N4 [2]	C15N4 C19N4 [2]	C23N41 C28N41 C31N41 [2]
CL1, CL21 CL2 CL22	Max. Wire Size	AWG mm ²	10 2.5	6 10	12 2.5	12 2.5	12 2.5	8 8	8 8	8 8
	Terminal Torque	lb-in N•m	6.73 0.76	35.4 4	6.73 0.76	6.73 0.76	6.73 0.76	20 2.3	20 2.3	20 2.3
L1 L2 L3	Max. Wire Size	AWG mm ²	10 2.5	6 10	4 10	2/0 35	4/0 70	350 MCM 120	2 x 300 MCM 185	3 x 500 MCM
	Terminal Torque	lb-in N•m	6.73 0.76	35.4 4	17.7 2	88 10	170 ^[4] 19	325 36.7	375 42.4	375
U/T1 V/T2 W/T3	Max. Wire Size	AWG mm ²	10 2.5	6 10	4 10	2/0 35	4/0 70	350 MCM 120	350 MCM 185	3 x 500 MCM
	Terminal Torque	lb-in N•m	6.73 0.76	35.4 4	17.7 2	88 10	170 ^[4] 19	325 36.7	325 36.7	375
+	Max. Wire Size	AWG mm ²	10 2.5	6 10	4 10	2/0 35	4/0 70	350 MCM 120	350 MCM 185	3 x 500 MCM
	Terminal Torque	lb-in N•m	6.73 0.76	35.4 4	17.7 2	88 10	170 ^[4] 19	325 36.7	325 36.7	375
PA PB	Max. Wire Size	AWG mm ²	10 2.5	6 10	8 6	4 16	2 35	2/0 35	2/0 35	3 x 500 MCM
	Terminal Torque	lb-in N•m	6.73 0.76	35.4 4	10.6 1.2	17.7 2	26.5 3	120 ^[3] 13.6	120 ^[3] 13.6	375
GND IN	Max. Wire Size	AWG mm ²	6 6	6 10	4 10	4 16	2 35	350 MCM 70	350 MCM 95	3 x 350 MCM
	Terminal Torque	lb-in N•m	17.7 2	35.4 4	17.7 2	26.5 3	26.5 3	325 36.7	325 36.7	325
GND OUT	Max. Wire Size	AWG mm ²	6 6	6 10	4 10	4 16	2 35	350 MCM 70	350 MCM 95	3 x 350 MCM
	Terminal Torque	lb-in N•m	17.7 2	35.4 4	17.7 2	26.5 3	26.5 3	325 36.7	325 36.7	325

[1] 60/75 °C copper.

[2] 75 °C copper.

[3] For 10 - 14 AWG (2.5 - 5 mm²) conductors, use 35.4 lb-in (4 N•m) torque; and for 8 AWG (8 mm²) conductors, use 40 lb-in (4.5 N•m) torque.

[4] For 2/0 AWG (35 mm²) and smaller conductors, use 88 lb-in (10 N•m) torque.

NOTE: The L1, L2, and L3 terminals on the ATV66C15N4 and C19N4 drive controllers are equipped with metric hex head bolts requiring a 13 mm socket. The other terminals (except PA & PB) require a 3/8 inch hex wrench, supplied with the drive controller. Terminals PA and PB require a 3/16 inch hex wrench, supplied with the drive controller.

CONTROL WIRING

NOTE:

The logic inputs and outputs and analog inputs and outputs are all referenced to Common (COM on J12 and J13). This Common is isolated from the input line and from ground (S on J13).

RMS voltage rating of the isolation barrier between Common and ground is 250 V. If Common is elevated with respect to earth by external user connections, then all devices connected to Common must be rated for the applied voltage.

J1 is located on the power board.

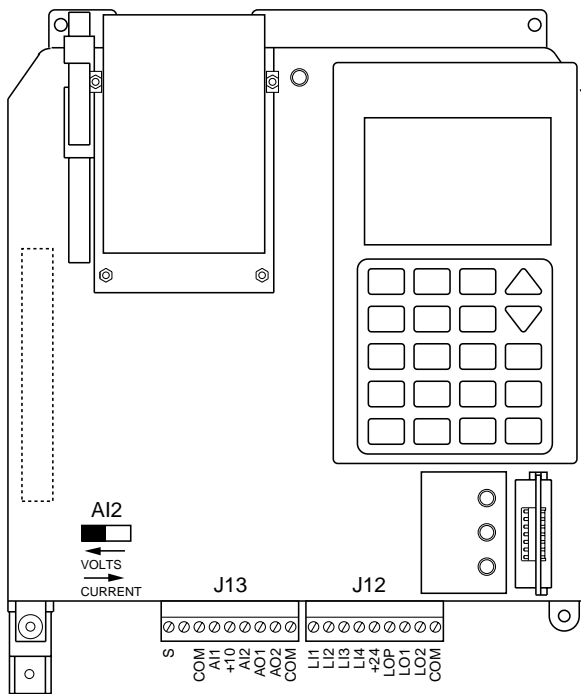

Figure 18: Terminal Strip Connections for Control Board

Table 20: Control Terminal Strip Characteristics

Connector	Terminal ^[1]	Function	Characteristics
J1 ^[2]	R1A ^[3] R1B R1C	N.O. contact ^[4] N.C. contact Common	Fault relay output
	R2A R2B R2C	N.O. contact ^[4] N.C. contact Common	Programmable relay output
J12 ^[2]	LI1	Logic input 1	24 V, 10 mA; State 0: V < 5 V; State 1: V>12 V; Vmax = 30 V
	LI2	Logic input 2	24 V, 10 mA; State 0: V < 5 V; State 1: V>12 V; Vmax = 30 V
	LI3	Logic input 3	24 V, 10 mA; State 0: V < 5 V; State 1: V>12 V; Vmax = 30 V
	LI4	Logic input 4	24 V, 10 mA; State 0: V < 5 V; State 1: V>12 V; Vmax = 30 V
	+24	Control supply	Is = 210 mA max. ^[5]
	LOP	LO supply input	Minimum: 12 V, Maximum: 30 V, quiescent current: typical 15 mA
	LO1	Logic output 1	24 V, 200 mA max. ^[5]
	LO2	Logic output 2	24 V, 200 mA max. ^[5]
J13 ^[2]	COM	Logic common	0 V
	S	Shield/Ground	
	COM	Space, for isolation	
	AI1	Speed reference common	0 V
	+10	Input 1: Speed ref. voltage	0-10 V, Z = 30 kΩ
	AI2	Reference supply	10 V, Is = 10 mA max.
	AI2	Input 2: Speed ref. current	4-20 mA ^[6] , Z = 250 Ω
J13 ^[2]	AO1	Analog output 1	0-20 mA, 12 V max. (programmable as 4-20 mA w/ keypad display)
	AO2	Analog output 2	0-20 mA, 12 V max. (programmable as 4-20 mA w/ keypad display)
	COM	Analog common	0 V

^[1] See circuit diagrams on page 57 and 58.

^[2] Max. wire size for all terminals: 14 AWG (2.5 mm²). Tightening torque: 3.5 lb-in (0.4 N•m).

^[3] Relay coil deenergizes on fault.

^[4] Contact state with drive controller deenergized.

^[5] Total current of + 24 V internal supply is 210 mA. Available current of the two logic outputs can be calculated as follows: each logic input requires 10 mA, each analog output requires 20 mA and the typical quiescent current of LOP is 15 mA. For example, in an application where three logic inputs and one analog output are used, the total available current is 210 mA - (3 x 10 mA) - (1 x 20 mA) - 15 mA = 145 mA to drive the logic output loads. If more current is required, an external supply must be used.

^[6] 0-20 mA, x-20 mA, 20-4 mA programmable with keypad display. 0-5 V (Z = 30 kΩ) selectable with switch on control board.

ELECTROMAGNETIC COMPATIBILITY (EMC)
For ATV66U41N4 to ATV66D79N4 and ATV66U41M2 to ATV66D46M2

This section provides information to integrators and end users who are including the drive controller as part of a machine being exported to Europe.

When addressing EMC, the ATV66 drive controller must be considered as a component. It is neither a machine nor a device ready for use in accordance with European standards (EN 60201-1 on the safety of machines, EN 50081 & 50082 on electromagnetic compatibility, and IEC 1800-3, "Adjustable Speed Electrical Power Drive Systems – Part 3: EMC Product Standard Including Specific Test Methods"). The ATV66 drive controller must be installed and implemented in compliance with applicable international and national standards in the location where the controller will be used. It is the responsibility of the integrator/end user to ensure that this machine conforms to these standards.

To aid the integrator/end user in meeting the requirements of the Electromagnetic Compatibility (EMC) directive in regards to ATV66 products, publication VVDED296034 (ATV66 Electromagnetic Compatibility Catalog) has been prepared. This publication, which recommends specific mitigation devices and installation methods, can be ordered from your local Square D Representative.

NOTICE

Wiring recommendations found in publication VVDED296034 apply to European power systems **ONLY** and do not apply to North American installations.

In order for a machine containing this drive controller to be exported to the European market, an optional RFI filter may be required. A listing of the available RFI Filters can be found in VVDED296034, referenced above.

NOTICE

RFI filters available for the ATV66 drive controller and listed in instruction manual VVDED296034 are qualified for use on European power systems **ONLY**.

In addition, for a machine containing this drive controller to be exported to the European Market, a motor cable ferrite core and a control cable ferrite core may need to be installed.

After February 1997, the following ATV66 drive controllers may be shipped with a package that contains one motor cable ferrite core and one control cable ferrite core:

- ATV66U41N4 – ATV66D79N4
- ATV66U41M2 – ATV66D46M2

Ferrite core kits (containing one motor cable ferrite core and one control cable ferrite core) are available from your Square D Distributor:

- VW3-A66470: for ATV66U41N4 – D46N4 and ATV66U41M2 – D33M2
- VW3-A66471: for ATV66D54N4 – D79N4 and ATV66D46M2

Installing the Ferrite Cores

DANGER

HAZARDOUS VOLTAGE

Read and understand these procedures before servicing ALTIVAR 66 drive controllers. Installation, adjustment, repair, and maintenance of these drive controllers must be performed by qualified personnel.

Failure to observe this instruction will result in death or serious injury.

Installing the Control Cable Ferrite Core

For the control wiring, use the smaller ferrite core supplied with the kit or drive controller.

All conductors except the shield drain wire must pass through the ferrite core (see Figure 19). The ferrite core must be installed around a non-shielded portion of the control cable as close as possible to the terminal strips on the control board and the 24 VDC I/O Extension Module (if installed).

Route control wiring and any exposed portions of the cable shield to avoid contact with other energized parts in the drive controller. Wire insulation must have appropriate voltage rating for the voltages present.

If the voltages and signals present on the conductors terminated on J1 & J24 warrant a separate control cable, this cable must also be equipped with its own ferrite core, installed as shown in Figure 19.

The quantity of conductors and the connection points made to the terminal strips illustrated are typical. The quantity and connection points depend on the application and control method selected for the drive controller. See bulletin VD0C06T306_ and page 41 of this bulletin for terminal strip definitions.

DANGER

HAZARDOUS VOLTAGE

- Remove all power before performing this procedure.
- Follow "Procedure 1: Bus Voltage Measurement" in Chapter 4 of this bulletin.

Failure to observe this instruction will result in death or serious injury.

⚠ DANGER

HAZARDOUS VOLTAGE — SEPARATE POWER

- Separate power may be present on the control board, power board, and I/O extension module (if installed) connectors.
- Verify that all power has been removed from J1, J2, and J13 connectors.
- If I/O extension module is installed, verify that all power is removed from J22, J23, and J24 connectors.

Failure to observe this instruction will result in death or serious injury.

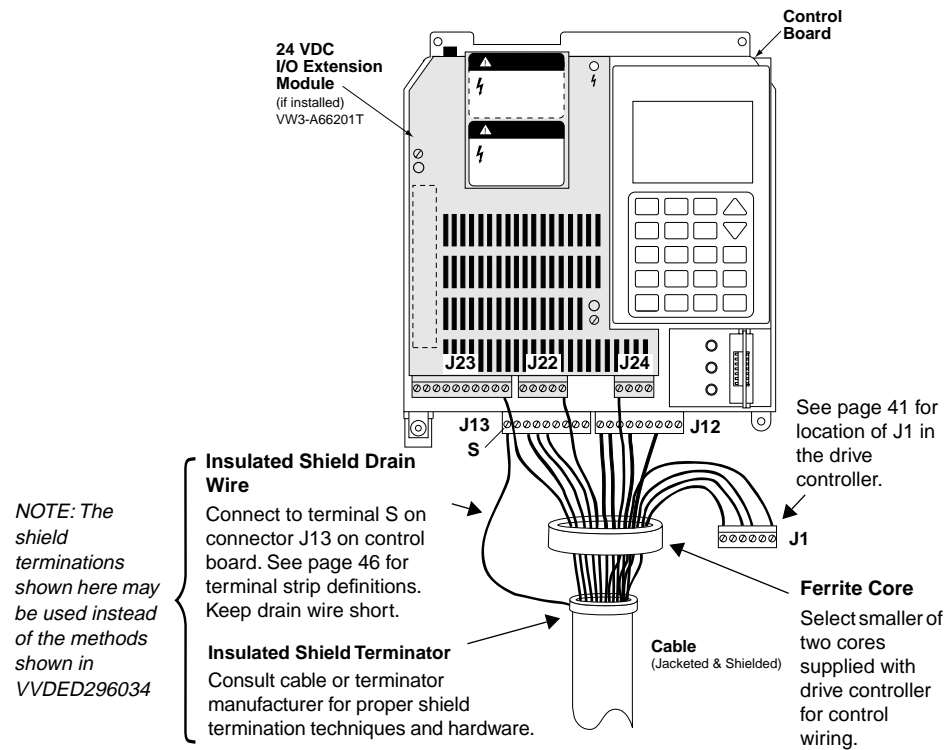

Figure 19: Typical Diagram of Control Wiring at Drive Controller

Installing the Motor Cable Ferrite Core

⚠ DANGER

HAZARDOUS VOLTAGE

- Remove all power before performing this procedure.
- Follow "Procedure 1: Bus Voltage Measurement" in Chapter 4 of this bulletin.

Failure to observe this instruction will result in death or serious injury.

⚠ DANGER

HAZARDOUS VOLTAGE — SEPARATE POWER

- Separate power may be present on the control board, power board, and I/O extension module (if installed) connectors.
- Verify that all power has been removed from J1, J2, and J13 connectors.
- If I/O extension module is installed, verify that all power is removed from J22, J23, and J24 connectors.

Failure to observe this instruction will result in death or serious injury.

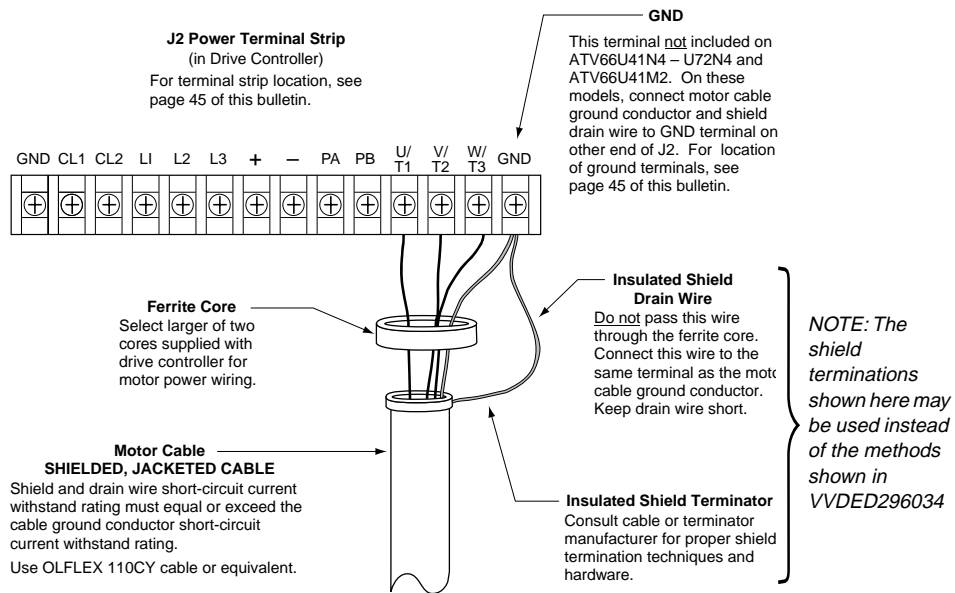

Figure 20: Typical Diagram of Motor Power Wiring at Drive Controller

USING THE LOGIC INPUTS (J12)

The logic inputs may be operated from either the internal supply or an external supply. Figure 21 shows the connections for operating the logic inputs from the internal power supply.

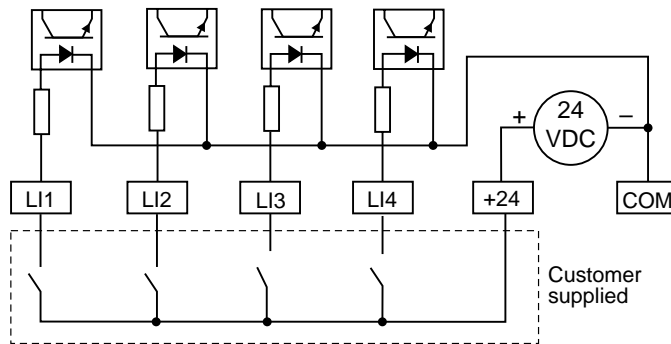

Figure 21: Operating the Logic Inputs from Internal Power Supply

Figure 22 shows the connections for operating the logic inputs from an external power supply.

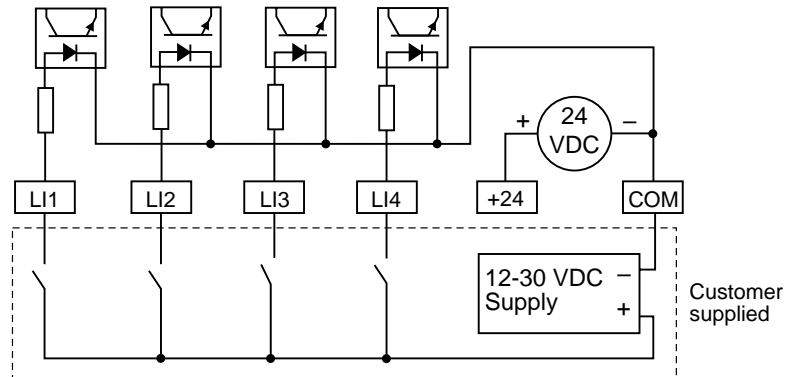

Figure 22: Operating the Logic Inputs from External Power Supply

You may assign the logic inputs to functions other than those set at the factory. Table 27 on page 67 lists factory settings. For information on other functions, refer to the Level 1 & 2 Configuration Manual.

USING THE LOGIC OUTPUTS (J12)

The logic outputs can be operated from either the internal supply or an external supply. You must use an external supply if logic outputs drive a load at a voltage other than 24 V or if the current required is greater than the available current as calculated in Note 5 in Table 20 on page 47.

NOTE: If you use the internal supply, you must connect the LOP to +24.

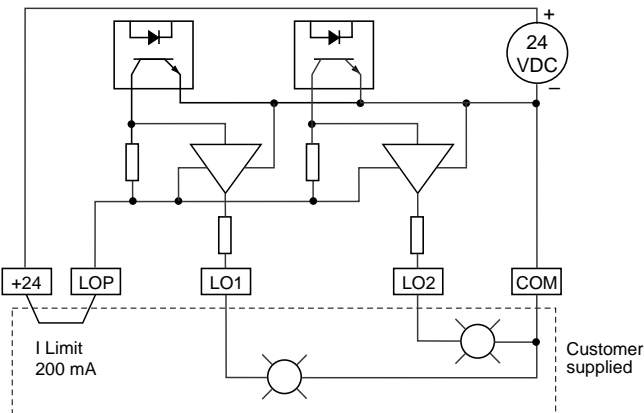

Figure 23: Operating the Logic Outputs from Internal Power Supply

Figure 24 shows the connection of an external supply for operating the logic outputs.

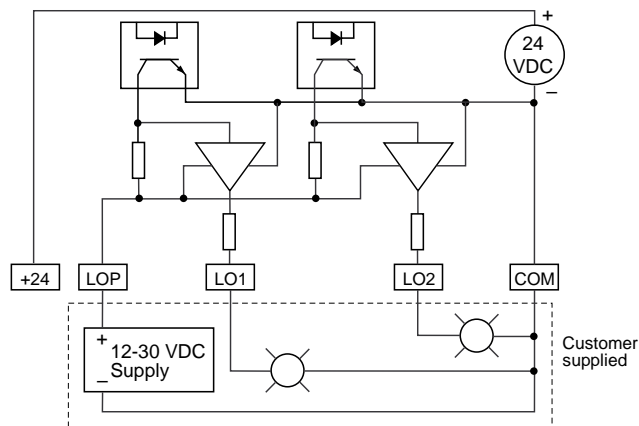

Figure 24: Operating the Logic Outputs from External Power Supply

USING THE SPEED REFERENCE INPUTS (J13)

The ALTIVAR 66 drive controller has two analog inputs for the speed reference, AI1 and AI2. AI1 is a 0-10 V voltage input. A speed potentiometer between 1 k Ω and 10 k Ω can be connected at COM, AI1 and +10 V as shown in Figure 25. AI2 is factory set as a 4-20 mA current input. It can be programmed to 0-20 mA, x-20 mA or 20-4 mA with the keypad display. It can also be set for 0-5 V with a switch on the control board.

- The speed reference controls the frequency of applied power to the motor. The actual shaft speed remains dependent on the acceleration and deceleration ramps, the torque capabilities of the motor/drive controller combination, the control type selected (see page 68), and the number of poles on the motor.
- The speed range is limited by Low Speed and High Speed settings. Factory settings are zero and nominal or base frequency.
- The speed reference inputs share the same common and are isolated from the input line and from ground.
- The +10 V internal supply (terminals +10V/COM) has a 10 mA supply capability and is protected against short circuits.
- If signals are present on both inputs, the values are summed for the speed reference. With the keypad display, they can be configured to be independent. For more information on configuration of the analog inputs, refer to the Level 1 & 2 Configuration Manual.

Figure 25 shows how the speed reference inputs may be connected. The speed reference inputs are isolated from the input line.

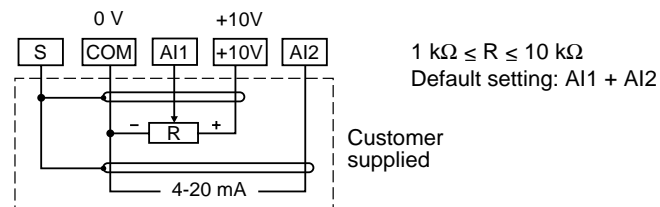

Figure 25: Using Speed Reference Inputs

USING THE ANALOG OUTPUTS (J13)

The ALTIVAR 66 drive controller has two 0-20 mA analog outputs, AO1 and AO2. They are both 0-20 mA current inputs. AO1 is factory set as proportional to motor frequency, with 20 mA corresponding to High Speed. AO2 is factory set as proportional to motor current, with 20 mA corresponding to twice the rated output current of the drive controller (see Tables 1 to 7 on pages 6-12).

- Maximum driving voltage is +12 V with an internal impedance of 100 Ω .
- The analog outputs can be assigned to other functions than those set at the factory. For information on other functions, refer to the Level 1 & 2 Configuration Manual.

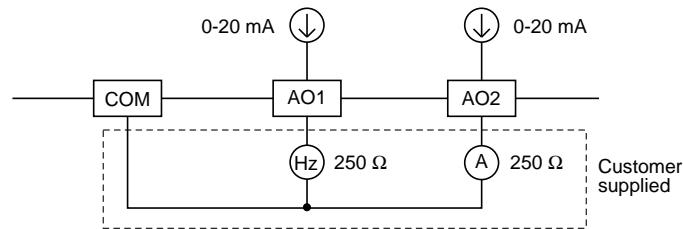

Figure 26: Analog Outputs

USING THE RELAY OUTPUTS (J1)

The ALTIVAR 66 drive controller has two voltage-free Form C relay output contacts (see Figure 27). The contacts have the following characteristics:

- Minimum voltage: +24 VDC; minimum current: 10 mA
- Maximum voltage: +30 VDC; maximum current: 2 A
- 120 VAC: maximum current 2 A
- 220 VAC: maximum current 1 A
- R1 is the drive controller fault relay. It is not programmable.

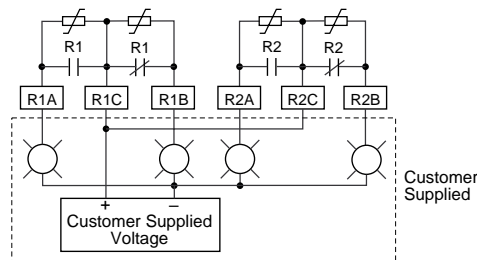

Figure 27: Relay Outputs

Contact state is shown with drive controller deenergized. You may assign relay contact outputs to functions other than those set at the factory. Table 27 on page 67 lists factory settings. For information on other functions, refer to the Level 1 & 2 Configuration Manual.

Maximum recommended fuse type and rating is Bussmann FNQ-2 or equivalent.

REMOVAL OF CL1, CL2 JUMPERS

Jumpers CL1 and CL2 are factory installed. If separate control power is required, these jumpers must be removed. To remove jumpers, use the following procedure:

ATV66U41N4 to D12N4 and ATV66U41M2 to U90M2 drive controllers:
Loosen the CL1 and CL2 screws and the L1 and L2 screws. Remove captive jumper wire assembly.

ATV66D16N4 to D79N4 and ATV66D12M2 to D46M2 drive controllers:

1. Loosen the front screws only (see Figure 28).

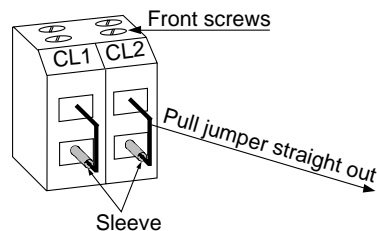

Figure 28: CL1, CL2 Jumper Removal

2. Using a pair of needle nose pliers, grasp the jumpers and pull straight out. The sleeve on the bottom terminal should remain.
3. Connect separate control power to the top terminals. **DO NOT** make connections to the bottom terminals which contain the sleeves.
4. Tighten the front screws to secure the connections.

ATV66C10N4 to C31N41 drive controllers: Loosen the CL1 and CL2 screws and the CL21 and CL22 screws. Remove jumpers. See Figures 16 and 17 on pages 42 and 43.

CONTROL CIRCUIT DIAGRAMS

This section contains wiring diagrams for 2- and 3-wire control circuits. The Level 1 & 2 Configuration Manual Operation explains 2- and 3-wire control.

3-Wire Control

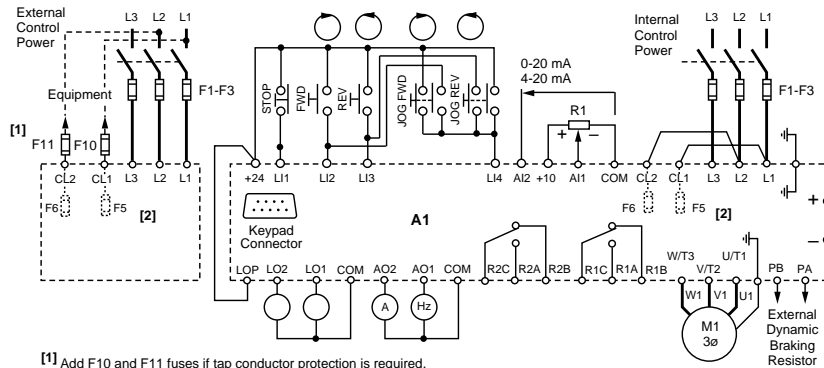

- [1] Add F10 and F11 fuses if tap conductor protection is required.
The CL1 and CL2 inputs of all ATV66 drive controllers are internally protected and require no external fusing.
[2] F5 and F6 fuses are present only on ATV66C10N4 to ATV66C31N41 drive controllers.

Figure 29: Recommended 3-Wire Control Circuit Diagram

Figure 29 is the recommended 3-wire control circuit diagram. It shows how to connect a branch circuit disconnect device and protective fusing to the drive controller. Additional sequencing logic may be required. Refer to Tables 21 to 26 on pages 59-63 for additional equipment required. The drive controller is factory set for 2-wire control. To set for 3-wire control, refer to the Level 1 & 2 Configuration Manual.

2-Wire Control

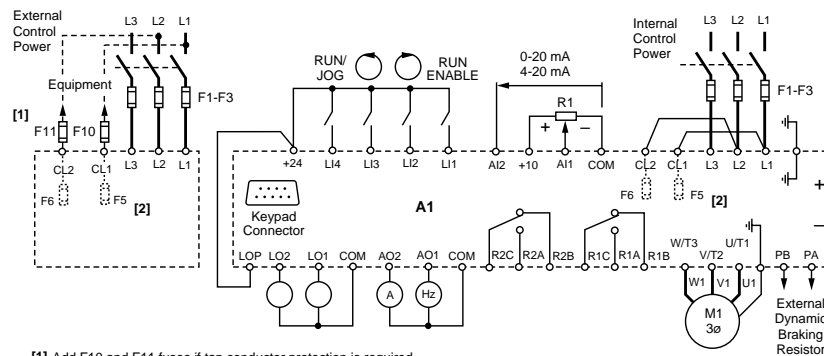

- [1] Add F10 and F11 fuses if tap conductor protection is required.
The internally protected CL1 and CL2 inputs of all ATV66 drive controllers require no external fusing.
[2] F5 and F6 fuses are present only on ATV66C10N4 to ATV66C31N41 drive controllers.

Figure 30: 2-Wire Control Circuit Diagram

Figure 30 is a 2-wire control circuit diagram. It shows how to connect a branch circuit disconnect device and protective fusing to the drive controller. Additional sequencing logic may be required. See Tables 21 to 26 on pages 59-63 for additional equipment required.

2-Wire Control with Isolation Contactor on Line Side (Coast to Stop)

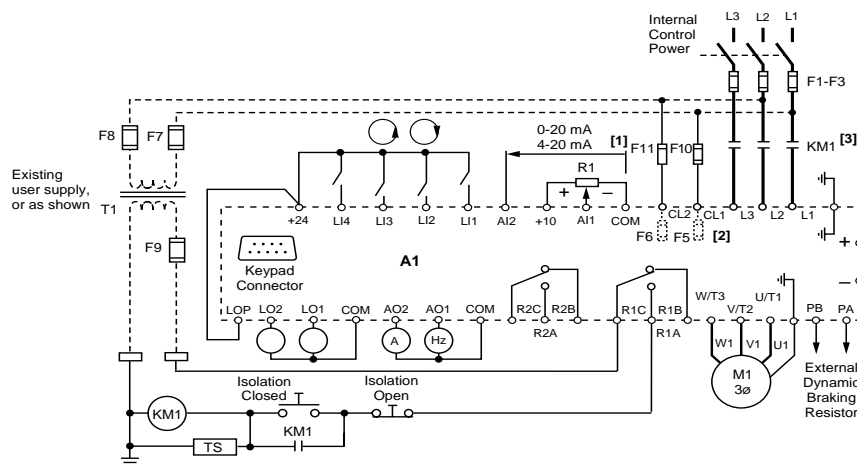

- [1] Add F10 and F11 fuses if tap conductor protection is required.
The internally protected CL1 and CL2 inputs of all ATV66 drive controllers require no external fusing.
- [2] F5 and F6 fuses are present only on ATV66C10N4 to ATV66C31N41 drive controllers.
- [3] The power circuit configuration of the ATV66C23N41 to ATV66C31N41 drive controllers does not support the use of an input isolation contactor.

Figure 31: 2-Wire Control Circuit Diagram with Isolation Contactor (see Table 21)

Figure 31 is a 2-wire control circuit diagram with an isolation contactor on the line side. It shows how to connect a branch circuit disconnect device and protective fusing to the drive controller. Additional sequencing logic may be required. Refer to Tables 21 to 26 on pages 59-63 for additional equipment required.

NOTE: External fusing is recommended for the ATV66C10N4 to ATV66C19N4 drive controllers when used with an isolation contactor on the line side. If the internal fuse installation is used, the short-circuit current rating of the isolation contactor must be coordinated with the overcurrent protective device protecting the drive controller feeder. **The maximum number of operations of the KM1 contactor or controller disconnect should not exceed one per minute for the ATV66U41N4 to ATV66D79N4 and ATV66U41M2 to ATV66D46M2 drive controllers and one per every two minutes for the ATV66C10N4 to ATV66C31N41 drive controllers.**

EQUIPMENT RECOMMENDATIONS

Equipment listings in Tables 21 through 26 are valid for all versions of the circuit diagrams.

Table 21: Recommended Equipment for 1 to 400 hp 460 V Drive Controllers^[1]

M1		A1		F1-F3				Input	KM1	TS	T1	F7, F8	F9
Motor		Controller ATV66***N4		Line Power Fuses Ratings, Fuse Class				Fuse Carriers Class T or CC	Line Contactor	Transient Suppressor	Xfmr [8]	Primary Xfmr Fuses [3]	Sec. Xfmr Fuses [3]
kW	hp	CT, VT low noise	VT	CC Fast Acting	T	Littelfuse JLS- [9]	Gould- Shawmut A4J- [9]						
0.75	1	U41	U41	600 V 6 A	600 V 6 A	600 V 6 A	—	9080- FB3611CC ^[2] T60060-3CR ^[3]	LC1- D2510G6	LA4-DA2G	9070- K50D20	FNO-R-1/ 4	FNO-R-1/2
1.5	2	U41	U41	600 V 10 A	600 V 10 A	600 V 10 A	—	9080- FB3611CC ^[2] T60060-3CR ^[3]	LC1- D2510G6	LA4-DA2G	9070- K50D20	FNO-R-1/ 4	FNO-R-1/2
2.2	3	U41	U41	600 V 15 A	600 V 15 A	600 V 15 A	—	9080- FB3611CC ^[2] T60060-3CR ^[3]	LC1- D2510G6	LA4-DA2G	9070- K50D20	FNO-R-1/ 4	FNO-R-1/2
3	4	U54	U41	600 V 20 A	600 V 20 A	600 V 20 A	—	9080- FB3611CC ^[2] T60060-3CR ^[3]	LC1- D2510G6	LA4-DA2G	9070- K50D20	FNO-R-1/ 4	FNO-R-1/2
4	5	U72	U54	600 V 20 A	600 V 20 A	600 V 20 A	—	9080- FB3611CC ^[2] T60060-3CR ^[3]	LC1- D2510G6	LA4-DA2G	9070- K50D20	FNO-R-1/ 4	FNO-R-1/2
5.5	7.5	—	U72	600 V 25 A	600 V 25 A	600 V 25 A	—	9080- FB3611CC ^[2] T60060-3CR ^[3]	LC1- D2510G6	LA4-DA2G	9070- K50D20	FNO-R-1/ 4	FNO-R-1/2
5.5	7.5	U90	—	—	600 V 30 A	600 V 30 A	600 V 30 A	T60060-3CR ^[3]	LC1- D2510G6	LA4-DA2G	9070- K50D20	FNO-R-1/ 4	FNO-R-1/2
7.5	10	D12	U90	—	600 V 35 A	600 V 35 A	600 V 35 A	T60060-3CR ^[3]	LC1- D2510G6	LA4-DA2G	9070- K50D20	FNO-R-1/ 4	FNO-R-1/2
11	15	—	D12	—	600 V 60 A	600 V 45 A	600 V 45 A	T60060-3CR ^[3]	LC1- D2510G6	LA4-DA2G	9070- K50D20	FNO-R-1/ 4	FNO-R-1/2
11	15	D16	—	—	600 V 60 A	600 V 60 A	600 V 60 A	T60060-3CR ^[3]	LC1- D2510G6	LA4-DA2G	9070- K50D20	FNO-R-1/ 4	FNO-R-1/2
15	20	D23	D16	—	600 V 70 A	600 V 70 A	600 V 70 A	T60100-3C ^[3]	LC1- D3210G6	LA4-DA2G	9070- K50D20	FNO-R-1/ 4	FNO-R-1/2
18.5	25	—	D23	—	600 V 90 A	600 V 90 A	600 V 80 A	T60100-3C ^[3]	LC1- D4011G6	LA4-DA2G	9070- K75D20	FNO-R-3/ 10	FNO-R-6/ 10
22	30	D33	—	—	600 V 90 A	600 V 90 A	600 V 90 A	T60100-3C ^[3]	LC1- D5011G6	LA4-DA2G	9070- K75D20	FNO-R-3/ 10	FNO-R-6/ 10
30	40	D46	D33	—	600 V 125 A	600 V 125 A	600 V 110 A	3 ea. T60200-1C ^[3]	LC1- D8011G6	LA4-DA2G	9070- K75D20	FNO-R-3/ 10	FNO-R-6/ 10
37	50	D54	D46	—	600 V 125 A	600 V 125 A	600 V 110 A ^[10]	3 ea. T60200-1C ^[3]	LC1- D8011G6	LA4-DA2G	9070- K75D20	FNO-R-3/ 10	FNO-R-6/ 10

[1] For F10 and F11, use Bussmann control fuse KTK-R-3. The recommended control fuse carrier is 9080-FB2611CC.
 [2] Square D Class CC Fuse Block numbers.
 [3] Bussmann part numbers.
 [4] Gould-Shawmut part numbers.
 [5] Ferraz part numbers.
 [6] Fuse mounted inside drive controller.
 [7] The power circuit configuration of the ATV66C23N4 to ATV66C31N4 drive controllers does not support the use of an input isolation contactor.
 [8] T1 has been dimensioned to supply KM1 coil inrush and sealed VA requirements only. Any user control / pilot device additions may require re-dimensioning of T1 VA capacity.
 [9] Manufacturer-specific fuse selection. DO NOT SUBSTITUTE.
 [10] 125 A rating allowable for ATV66D54N4 controller.

Table 21: Recommended Equipment for 1 to 400 hp 460 V Drive Controllers^[1] (Continued)

M1 Motor		A1 Controller ATV66***N4		F1-F3 Line Power Fuses Ratings, Fuse Class			Input Fuse Carriers Class T or CC	KM1 Line Contactor	TS Transient Suppressor	T1 Xfmr [8]	F7, F8 Primary Xfmr Fuses [3]	F9 Sec. Xfmr Fuses [3]	
kW	hp	CT, VT low noise	VT	CCFast Acting	T	Littelfuse JLS- [9]	Gould- Shawmut A4J- [9]						
45	60	D64	D54	—	600 V 175 A	600 V 175 A	600 V 175 A	3 ea. T60200-1C ^[3]	LC1-F115G6	LA9-F980	9070- K200D20	FNQ-R-1- 1/4	FNQ-R-1- 6/10
55	75	D79	D64	—	600 V 200 A	600 V 200 A	600 V 200 A	3 ea. T60200-1C ^[3]	LC1-F115G6	LA9-F980	9070- K200D20	FNQ-R-1- 1/4	FNQ-R-1- 6/10
75	100	—	D79	—	600 V 225 A	600 V 225 A	600 V 225 A	3 ea. T60400-1C ^[3]	LC1-F150G6	LA9-F980	9070- K200D20	FNQ-R-1- 1/4	FNQ-R-1- 6/10

[1] For F10 and F11, use Bussmann control fuse KTK-R-3. The recommended control fuse carrier is 9080-FB2611CC.
 [2] Square D Class CC Fuse Block numbers.
 [3] Bussmann part numbers.
 [4] Gould-Shawmut part numbers.
 [5] Ferraz part numbers.
 [6] Fuse mounted inside drive controller.
 [7] The power circuit configuration of the ATV66C23N4 to ATV66C31N4 drive controllers does not support the use of an input isolation contactor.
 [8] T1 has been dimensioned to supply KM1 coil inrush and sealed VA requirements only. Any user control / pilot device additions may require re-dimensioning of T1 VA capacity.
 [9] Manufacturer-specific fuse selection. DO NOT SUBSTITUTE.
 [10] 125 A rating allowable for ATV66D54N4 controller.

Table 22: Recommended Semiconductor Fuses for 1 - 400 hp 460 V Controllers

M1 Motor		A1 Controller ATV66***N4		F1-F3 Line Power Fuses Semiconductor Fuse Class	Input Fuse Carriers [3]	KM1 Line Contactor	TS Transient Suppressor	T1 Xfmr [8]	F7, F8 Primary Xfmr Fuses [3]	F9 Sec. Xfmr Fuses [3]
kW	hp	CT, VT low noise	VT							
75	100	C10	—	FWH400A ^[3] A50P400 ^[4]	6 ea. BH-1133	LC1-F150G6	LA9-F980	9070- K200D20	FNQ-R-1-1/4	FNQ-R-1-6/10
90	125	C13	C10	FWH400A ^[3] A50P400 ^[4]	6 ea. BH-1133	LC1-F265G7	LA9-F980	9070- K350D20	FNQ-R-1-6/10	FNQ-R-2-8/10
110	150	C15	—	FWH500A ^[3] A50P500 ^[4]	6 ea. BH-3245	LC1-F265G7	LA9-F980	9070- K350D20	FNQ-R-1-6/10	FNQ-R-2-8/10
110	150	—	C13	FWH400A ^[3] A50P400 ^[4]	6 ea. BH-1133	LC1-F265G7	LA9-F980	9070- K350D20	FNQ-R-1-6/10	FNQ-R-2-8/10
132	200	C19	—	FWH600A ^[3] A50P600 ^[4]	6 ea. BH-3245	LC1-F330G7	LA9-F980	9070- K250D20	FNQ-R-1-1/4	FNQ-R-2
132	200	—	C15	FWH500A ^[3] A50P500 ^[4]	6 ea. BH-3245	LC1-F330G7	LA9-F980	9070- K250D20	FNQ-R-1-1/4	FNQ-R-2
160	250	C23	C23	FWH700A ^[3] 170M6711 ^[3] N300231 ^[5]	[6]	[7]	[7]	[7]	[7]	[7]
200	300	C28	C23	FWH800A ^[3] 170M6712 ^[3] P300232 ^[5]	[6]	[7]	[7]	[7]	[7]	[7]

[1] For F10 and F11, use Bussmann control fuse KTK-R-3. The recommended control fuse carrier is 9080-FB2611CC.
 [2] Square D Class CC Fuse Block numbers.
 [3] Bussmann part numbers.
 [4] Gould-Shawmut part numbers.
 [5] Ferraz part numbers.
 [6] Fuse mounted inside drive controller.
 [7] The power circuit configuration of the ATV66C23N4 to ATV66C31N4 drive controllers does not support the use of an input isolation contactor.
 [8] T1 has been dimensioned to supply KM1 coil inrush and sealed VA requirements only. Any user control / pilot device additions may require re-dimensioning of T1 VA capacity.

Table 22: Recommended Semiconductor Fuses for 1 - 400 hp 460 V Controllers

M1 Motor		A1 Controller ATV66***N4		F1-F3 Line Power Fuses Semiconductor Fuse Class	Input Fuse Carriers [3]	KM1 Line Contactor	TS Transient Suppressor	T1 Xfmr [8]	F7, F8 Primary Xfmr Fuses [3]	F9 Sec. Xfmr Fuses [3]
kW	hp	CT, VT low noise	VT							
220	350	C31	C28	FWH900A ^[3] 170M6713 ^[3] Q300233 ^[5]	[6]	[7]	[7]	[7]	[7]	[7]
250	400	—	C31	FWH900A ^[3] 170M6713 ^[3] Q300233 ^[5]	[6]	[7]	[7]	[7]	[7]	[7]

[1] For F10 and F11, use Bussmann control fuse KTK-R-3. The recommended control fuse carrier is 9080-FB2611CC.

[2] Square D Class CC Fuse Block numbers.

[3] Bussmann part numbers.

[4] Gould-Shawmut part numbers.

[5] Ferraz part numbers.

[6] Fuse mounted inside drive controller.

[7] The power circuit configuration of the ATV66C23N4 to ATV66C31N4 drive controllers does not support the use of an input isolation contactor.

[8] T1 has been dimensioned to supply KM1 coil inrush and sealed VA requirements only. Any user control / pilot device additions may require re-dimensioning of T1 VA capacity.

Table 23: Maximum Allowable Line Fuse (F1 to F3) for 460 V Drive Controllers

Controller ATV66**N4	Class CC (Fast-Acting)	Class T	Littelfuse JLS-[4]	Gould-Shawmut A4J-[4]	Semiconductor
U41, U54, U72	600 V, 25 A	600 V, 35 A	600 V, 30 A	—	—
U90, D12	—	600 V, 60 A	600 V, 45 A	600 V, 45 A	—
D16, D23	—	600 V, 100 A	600 V, 100 A	600 V, 80 A	—
D33, D46	—	600 V, 125 A	600 V, 125 A	600 V, 110 A	—
D54, D64, D79	—	600 V, 225 A	600 V, 225 A	600 V, 225 A	—
C10	—	—	—	—	FWH500A [1] A50P500 [2]
C13, C15, C19	—	—	—	—	FWH600A [1] A50P600 [2]
C23, C28, C31	—	—	—	—	FWH900A [1] 170M6713 [2] Q300233 [3]

- [1] Bussmann part numbers.
[2] Gould-Shawmut part numbers.
[3] Ferraz part numbers.
[4] Manufacturer-specific fuse selection. DO NOT SUBSTITUTE.

Table 24: Recommended Equipment for 1 to 50 hp 208/230 V Drive Controllers^[1]

M1		A1		F1-F3				Input	KM1	TS	T1	F6, F7		F8
Motor		Controller ATV66**M2		Line Power Fuses Ratings, Fuse Class				Fuse Carriers Class T or CC	Line Contactor	Transient Suppressor	Xfmr [3]	Primary Xfmr Fuses [2]		Sec. Xfmr Fuses [2]
kW	hp	CT,VT low noise	VT	CC Fast Acting	T	Littelfuse JLS- [5]	Gould- Shawmut A4J- [5]					208 V	230 V	
0.75	1	U41	U41	600 V 10 A	600 V 10 A	600 V 10 A	—	9080- FB3611CC [4] T60030-3CR [2]	LC1- D2510G6	LA4-DA2G	9070- K50D20	FNO-R-1/ 2	FNO-R-1/ 2	FNO-R-1/ 2
1.2	1.5	U41	U41	600 V 15 A	600 V 15 A	600 V 15 A	—	9080- FB3611CC [4] T60030-3CR [2]	LC1- D2510G6	LA4-DA2G	9070- K50D20	FNO-R-1/ 2	FNO-R-1/ 2	FNO-R-1/ 2
1.5	2	U41	U41	600 V 20 A	600 V 20 A	600 V 20 A	—	9080- FB3611CC [4] T60030-3CR [2]	LC1- D2510G6	LA4-DA2G	9070- K50D20	FNO-R-1/ 2	FNO-R-1/ 2	FNO-R-1/ 2
2.2	3	U41	U41	600 V 25 A	600 V 25 A	600 V 25 A	—	9080- FB3611CC [4] T60030-3CR [2]	LC1- D2510G6	LA4-DA2G	9070- K50D20	FNO-R-1/ 2	FNO-R-1/ 2	FNO-R-1/ 2
3	4	—	U41	600 V 25 A	600 V 25 A	600 V 25 A	—	9080- FB3611CC [4] T60030-3CR [2]	LC1- D2510G6	LA4-DA2G	9070- K50D20	FNO-R-1/ 2	FNO-R-1/ 2	FNO-R-1/ 2
4	5	U72	U72	—	600 V 35 A	600 V 35 A	600 V 35 A	T60060-3C [2]	LC1- D2510G6	LA4-DA2G	9070- K50D20	FNO-R-1/ 2	FNO-R-1/ 2	FNO-R-1/ 2
5.5	7.5	U90	U72	—	600 V 45 A	600 V 45 A	600 V 45 A	T60060-3C [2]	LC1- D2510G6	LA4-DA2G	9070- K50D20	FNO-R-1/ 2	FNO-R-1/ 2	FNO-R-1/ 2
7.5	10	D12	U90	—	600 V 60 A	600 V 60 A	600 V 60 A	T60060-3C [2]	LC1- D3210G6	LA4-DA2G	9070- K50D20	FNO-R-1/ 2	FNO-R-1/ 2	FNO-R-1/ 2

- [1] For F10 and F11, use Bussmann control fuse KTK-R-3. The recommended control fuse carrier is 9080-FB2611CC.
[2] Bussmann part numbers.
[3] T1 has been dimensioned to supply KM1 coil inrush and sealed VA requirements only. Any user control / pilot device additions may require re-dimensioning of T1 VA capacity.
[4] Square D Class CC Fuse Block numbers.
[5] Manufacturer-specific fuse selection. DO NOT SUBSTITUTE.

Table 24: Recommended Equipment for 1 to 50 hp 208/230 V Drive Controllers^[1] (Continued)

M1		A1		F1-F3			Input	KM1	TS	T1	F6, F7		F8	
Motor		Controller ATV66***M2		Line Power Fuses Ratings, Fuse Class			Fuse Carriers Class T or CC	Line Contactor	Transient Suppressor	Xfmr [3]	Primary Xfmr Fuses [2]		Sec. Xfmr Fuses [2]	
kW	hp	CT,VT low noise	VT	CC Fast Acting	T	Littelfuse JLS- [5]	Gould- Shawmut A4J- [5]				208 V	230 V		
11	15	D16	D12	—	600 V 90 A	600 V 90 A	600 V 90 A	3 ea. T60100-1C ^[2]	LC1- D4010G6	LA4-DA2G	9070- K75D20	FNO-R-1	FNO-R-3/ 4	FNO-R-6/ 10
15	20	D23	D23	—	600 V, 110 A	600 V 110 A	600 V 110 A	3 ea. T60200-1C [2]	LC1- D8011G6	LA4-DA2G	9070- K75D20	FNO-R-1	FNO-R-3/ 4	FNO-R-6/ 10
18.5	25	D33	D23	—	600 V, 150 A	600 V 150 A	600 V 150 A	3 ea. T60200-1C [2]	LC1- D8011G6	LA4-DA2G	9070- K75D20	FNO-R-1	FNO-R-3/ 4	FNO-R-6/ 10
22	30	D33	D33	—	600 V, 150 A	600 V 150 A	600 V 150 A	3 ea. T60200-1C [2]	LC1- D8011G6	LA4-DA2G	9070- K75D20	FNO-R-1	FNO-R-3/ 4	FNO-R-6/ 10
30	40	D46	D33	—	600 V, 200 A	600 V 200 A	600 V 200 A	3 ea. T60200-1C [2]	LC1- F115G6	LA9-F980	9070- K200D20	FNO-R-2- 1/4	FNO-R-1- 6/10	FNO-R-1- 6/10
37	50	—	D46	—	600 V, 250 A	600 V 250 A	600 V 250 A	3 ea. T60400-1C [2]	LC1- F115G6	LA9-F980	9070- K200D20	FNO-R-2- 1/4	FNO-R-1- 6/10	FNO-R-1- 6/10

[1] For F10 and F11, use Bussmann control fuse KTK-R-3. The recommended control fuse carrier is 9080-FB2611CC.

[2] Bussmann part numbers.

[3] T1 has been dimensioned to supply KM1 coil inrush and sealed VA requirements only. Any user control / pilot device additions may require re-dimensioning of T1 VA capacity.

[4] Square D Class CC Fuse Block numbers.

[5] Manufacturer-specific fuse selection. DO NOT SUBSTITUTE.

Table 25: Maximum Allowable Line Fuse (F1 to F3) for 208/230 V Drive Controllers

Controller ATV66***M2	Class CC (Fast-Acting)	Class T	Littelfuse JLS- ^[1]	Gould-Shawmut A4J- ^[1]
U41	600 V, 25 A	600 V, 45 A	600 V, 35 A	600 V, 35 A
U72, U90	—	600 V, 100 A	600 V, 100 A	600 V, 80 A
D12, D16	—	600 V, 125 A	600 V, 125 A	600 V, 100 A
D23, D33	—	600 V, 225 A	600 V, 225 A	600 V, 225 A
D46	—	600 V, 250 A	600 V, 250 A	600 V, 250 A

[1] Manufacturer-specific fuse selection. DO NOT SUBSTITUTE.

Table 26: Recommended Equipment for all Drive Controllers

R1	Potentiometer	9001 K2106
—	Push buttons	9001 KR1UH13
—	Control station enclosure (accepts R1 and two push buttons)	9001 KYAF3

Mounting and Replacing Line Power Fuses in ATV66C10N4 to C19N4 Drive Controllers

Line power fuses for ATV66C10N4 to C19N4 drive controllers can be mounted either externally or internally. To mount or replace fuses internal to the drive controller:

1. Perform Bus Voltage Measurement Procedure on page 78.
2. Open inside door by loosening the two knurled screws located to the left of the control board.
3. Remove plastic terminal shield.
4. When initially installing fuses, remove the three shorting bars located at terminals 1, 2, and 3. Otherwise, remove the old fuses. Save the screws.
5. Using the screws from step 4, mount the fuses in place of the shorting bars.
 - Screws: M8 x 1.25 x 16 mm
 - Recommended torque: 131-164 lb-in (14.8-18.5 N•m)
6. Replace plastic terminal shield.
7. Close inside door and tighten screws.
8. Close drive controller door.

Replacing Line Power Fuses in ATV66C23N41 to C31N41 Drive Controllers

Line power fuses for the ATV66C23N41 to ATV66C31N41 drive controllers can be mounted internally within the cabinet enclosure. To replace internal fuses to the drive controller:

1. Perform Bus Voltage Measurement Procedure on page 78.
2. Locate the line fuses (F1-F3), as shown in Figure 38 on page 80. These fuses are directly beneath the main disconnect switch.
3. Remove the old fuses. Save the mounting hardware.
4. Using the hardware from step 3, mount the replacement fuses.
 - Screws: M12 x 1.75 x 35 mm.
 - Recommended torque: 486-608 lb-in (54.9-68.6 N•m)
5. Close drive controller door.

CHAPTER 3—START-UP

INTRODUCTION	66
FACTORY SETTINGS	67
CONTROL TYPES	68
Normal	68
High Torque	69
Special	69
NOLD (No Load)	69
MOTOR THERMAL OVERLOAD PROTECTION	70
ADJUSTMENT OF MOTOR OVERLOAD	71
AVAILABLE MOTOR TORQUE	72
Continuous Duty	72
Overtorque Capability and Speed Range	72
Overspeed Operation ($f \geq 50/60$ Hz)	73
Regenerative Operation	73
Driving Torque Production Envelope	73
MOTOR CONSIDERATIONS	74
Motor Insulation	75
Motors in Parallel	75
Output Contactor Between Motor and Drive Controller	75
Additional Motor Connected Downstream of the Drive Controller	75
Using a Synchronous Permanent Magnet or Wound-Field Motor	76
Using a Synchronous Reluctance Motor	76

INTRODUCTION

The ALTIVAR® 66 drive controller is software driven. The factory default settings may require reconfiguration. If the factory settings do not match the requirements of your application, or if you must reconfigure the drive controller for a new application, refer to the Level 1 & 2 Configuration Manual.

Generally, at least four key parameters should be checked and adjusted if necessary prior to motor operation:

- Nominal Current
- Motor Overload
- Control Type
- Rotation Normalization (Note: Changing the wiring of drive controller line terminals L1, L2, and L3 does not affect the motor rotation direction).

If the ALTIVAR 66 drive controller is supplied as part of a larger system, also refer to the documentation supplied with the system for applicable configuration settings.

The drive controller is equipped with a number of control algorithms and features for flexibility in application. Self-tuning is incorporated into several of the control algorithms to allow optimal control of the motor. The factory default control type, Normal control, incorporates such a feature.

Observe the following precautions when using Normal or High Torque control types:

- The adjustment range of the Nominal Current parameter is 45% to 105% of the drive controller rated output current, allowing the use of motors with horsepower equal to or one horsepower size less than the drive controller horsepower. To adjust the Nominal Current parameter, see the Level 1 & 2 Configuration Manual.
- Before powering up for the first time, compare motor nameplate current rating with output current in Table 1, 2, 3, 5, 6 or 7, depending on drive controller configuration. If the motor rating is not within 45% to 105% of the value in the table, it is necessary to use a different drive controller. For the ATV66U41N4, use the output current corresponding to motor horsepower and set Motor Power parameter for that value. See the Level 1 & 2 Configuration Manual.

 CAUTION

MOTOR OVERHEATING

Each time the drive controller is powered up with Normal or High Torque control type selected, direct current equal to the drive controller rated current is injected into the motor.

Do not use motors with a full load current rating that is not within the adjustment range of the drive controller Nominal Current parameter.

Failure to follow this instruction can result in injury or equipment damage.

- When the drive controller is powered up, direct current equal to the motor rated current is injected into the motor, allowing the drive controller to determine the resistance of the motor and set the motor parameters.
- For optimal torque performance, operate the drive controller and motor under no load at 50/60 Hz during initial commissioning or any time the motor is changed. This allows the drive controller to measure key motor parameters.
- The Nominal Current parameter **must** be set on the drive controller keypad display to match the motor full load current rating. If the Nominal Current parameter cannot be adjusted to the motor full load current, Normal and High Torque control types cannot be used for the application.
- For multiple motor applications, contact your local representative.

FACTORY SETTINGS

The ALTIVAR 66 drive controller is factory set to meet most applications. If the following values are compatible with the application, the drive controller can be started up. If the values listed below do not match the requirements of your application, change their settings with the keypad display. For detailed use of the keypad display, refer to the Level 1 & 2 Configuration Manual.

Table 27: Factory Settings – Functions

Function	Factory Setting
Nominal Output Voltage and Frequency	Automatically set at first power-up according to the input frequency: 50 Hz input: 400 V (ATV66***N4 units); 230 V (ATV66***M2 units) 60 Hz input: 460 V (ATV66***N4 units); 230 V (ATV66***M2 units)
Nominal Current	0.9 times permanent output current of drive controller
Volts/Frequency Law	Normal linear law IR compensation preset at 100%
Slip Compensation	On and automatic
Operating Frequency Range	50 Hz input: 0.1 to 50 Hz 60 Hz input: 0.1 to 60 Hz

Table 27: Factory Settings – Functions (Continued)

Function	Factory Setting
Ramp Times	Acceleration: 3 s Deceleration: 3 s Ramp time: automatically adapted in case of overtorque
Braking-To-Standstill (low speed)	Automatic by DC injection for 0.5 s when frequency drops below 0.1 Hz DC current level: 0.7 times the permanent output current of drive controller
Motor Thermal Protection	0.9 times continuous output current of drive controller, see page 70
Jog Function	Speed: limited to 5 Hz Ramp time: 0.1 s Time between two pulses: 0.5 s
Control Scheme	Two-wire control

Table 28: Factory Settings – Inputs and Outputs

Inputs and Outputs	Terminal	Factory Setting	Programmable
Logic Inputs	LI1	Run Enable	No
	LI2	Run Forward	No
	LI3	Run Reverse	Yes
	LI4	Jog	Yes
Analog Inputs	AI1	Speed Reference 1	Yes
	AI2	Speed Reference 2	Yes
Logic Outputs	LO1	At Speed	Yes
	LO2	Current Limit	Yes
	R1	Fault	No
	R2	Running State	Yes
Analog Outputs	AO1	Motor Speed	Yes
	AO2	Motor Current	Yes

CONTROL TYPES

The control type affects the amount of available motor torque. The control type setting is dependent on the type of motor used and the application. The following paragraphs describe control types. For information on changing the control type, see the Level 1 & 2 Configuration Manual.

Normal

The Normal control type is the factory setting for both constant and variable torque configurations. Normal is a sensorless flux vector control. In order to create high torque at low speeds, the drive controller maintains a 90° phase relationship between the rotor and stator electromagnetic fields by continuously calculating the position of the rotor in relation to the electrical position of the stator. It is generally applicable on asynchronous motors and provides good torque performance. Because there are fewer parameters than

with the High Torque control type, the process requires less tuning. When using Normal control, the motor horsepower must be equal to or one horsepower size less than the drive controller horsepower.

When Normal control type is used on a constant torque configuration, self-tuning is active. When the drive controller is powered up, a pulse of direct current equal to motor rated current is injected into the motor, allowing the drive controller to determine the resistance of the motor to set the motor parameters.

High Torque

High Torque control is also sensorless flux vector control, available when the drive controller is configured for constant torque. In order to create high torque at low speeds, the drive controller maintains a 90° phase relationship between the rotor and stator electromagnetic fields by continuously calculating the position of the rotor in relation to the electrical position of the stator. High Torque provides more flexible setup and optimized parameters than the Normal control type, therefore offering better torque performance. Select this control type when controlling only one motor in constant torque configuration. When using High Torque control, the motor horsepower must be equal to or one horsepower size less than the drive controller horsepower.

When High Torque control type is used, self-tuning is active. When the drive controller is powered up, a pulse of direct current equal to motor rated current is injected into the motor, allowing the drive controller to determine the resistance of the motor to set the motor parameters.

Special

The Special control type, available when the drive controller is configured for constant torque, maintains a constant volts/frequency ratio throughout the speed range. For example, if the voltage to the motor is 460 V at 60 Hz, it will be 230 V at 30 Hz, functioning as a current limited power supply.

Use Special control when controlling synchronous permanent magnet motors, synchronous wound-field motors, and synchronous reluctance motors.

NOLD (No Load)

NOLD control is only available when the drive controller is configured for variable torque. This function maintains a constant volts/frequency ratio during acceleration. Once the motor is stable, however, voltage to the motor is automatically reduced as a function of load. At light load, the motor voltage is minimized, even at motor base speed. This reduces audible motor noise without reducing motor RPM. NOLD control should not be used with motors in parallel. For more information, see the Level 1 & 2 Configuration Manual.

MOTOR THERMAL OVERLOAD PROTECTION

CAUTION

LOSS OF MOTOR OVERLOAD PROTECTION

When using external overload relays connected to drive controller output, overload relay must be capable of operation over the expected range of drive controller output frequencies (including direct current).

When DC injection braking is used:

- Overload relay must be suitable for operation with direct current flowing to the motor.
- Do not use overload relays equipped with current transformers for sensing the motor current.

Failure to follow these instructions can result in equipment damage.

CAUTION

MOTOR OVERHEATING

This drive controller does not provide direct thermal protection for the motor. Use of a thermal sensor in the motor may be required for protection at all speeds and loading conditions. Consult motor manufacturer for thermal capability of motor when operated over desired speed range.

Failure to follow this instruction can result in injury or equipment damage.

- ALTIVAR 66 drive controllers provide indirect motor thermal protection by continuously calculating the theoretical thermal state of the motor. The drive controller will trip if this state reaches 109% of nominal current.
- The microprocessor calculates the theoretical thermal state of the motor from:
 - Motor thermal time constant based on assumed motor power
 - Operating frequency
 - Current absorbed by the motor
 - Running time
 - Assumed maximum ambient temperature of 40 °C around the motor

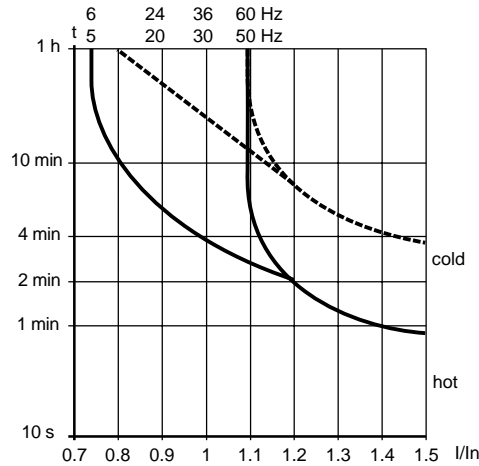

Note: for variable torque configuration, use the same curves but limit overload to $I/In = 1.1$.

Figure 32: Thermal Curves (Constant Torque)

- External thermal overload relays are required when more than one motor is connected to the output or when the motor connected to the drive controller is less than half of the drive controller rating, or with a permanent magnet or wound-field motor. See Table 29 on page 76.
- The thermal state of the drive controller is not automatically reset when power is removed.

ADJUSTMENT OF MOTOR OVERLOAD

To adjust Motor Overload, first select the type of protection in the 7.4 → Fault Management menu. Four types of protection are available from the Motor Overload screen:

- Self-Cooled Motor
- Forced-Ventilation Motor
- Manual Tuning
- No Thermal Protection

The drive controller is factory set for a self-cooled motor. Once the type of protection is selected, the Motor Overload current can be set in either the 1 → Parameter Setting menu or in the 7.4 → Fault Management menu. Motor Overload can be adjusted from 0.45 to 1.15 times the nominal drive controller current, factory preset at 0.9 times the nominal drive controller current. Adjust Motor Overload value to nominal motor current. For more information on configuring the drive controller, refer to the Level 1 & 2 Configuration Manual.

AVAILABLE MOTOR TORQUE

Continuous Duty

For continuous duty reduced speed applications, motor torque de-rating may be necessary. This de-rating is linked to two causes:

- Although the current waveform is similar to a sine wave, motor heating is slightly greater than when operating directly from the input line supply. The resulting torque de-rating is approximately 5%. For 1.0 service factor motors, de-rating must be considered when choosing the continuous torque production capability of the motor at nameplate speed. For 1.15 service factor motors, de-rating of motor continuous torque capability is not required at nameplate rated speed.
- For self-ventilating motors, ventilation produced by the internal shaft fan decreases as speed is reduced, therefore requiring de-rating of the maximum continuous torque capability of the motor. Generally, the required de-rating occurs at approximately 50% of nameplate motor speed. Since motor designs vary, consult the motor manufacturer for the required de-rating for a specific motor.

Overtorque Capability and Speed Range

The driving overtorque capabilities of a given motor are determined by: the motor NEMA design category (Design B, Design D, etc.), no-load (magnetizing) current of the motor at nameplate speed, maximum transient output current of the drive controller, and the applied V/Hz at reduced speed.

Maximum transient overtorque capability is typically:

- Normal (constant torque and variable torque) and High Torque (constant torque) control types:
 - ATV66U41N4 to D12N4 and ATV66U41M2 to D12M2: 170% (constant torque) or 110% (variable torque) over 50:1 speed range
 - ATV66D16N4 to C31N41 and ATV66D16M2 to D46M2: 150% (constant torque) or 110% (variable torque) over 50:1 speed range
- Special (constant torque) and NOLD (variable torque) control types:
 - ATV66U41N4 to C31N41 and ATV66U41M2 to D46M2: 150% (constant torque) or 110% (variable torque) over 10:1 speed range

With Special and NOLD control, the motor overtorque capability begins to decrease below 50% of motor nameplate speed. To improve low speed overtorque performance, adjust the Voltage Boost parameter. See the Level 1 & 2 Configuration Manual.

Overspeed Operation ($f \geq 50/60$ Hz)

With an adjustable frequency drive controller, operation at speeds greater than motor nameplate speed may be possible. The following must be considered:

CAUTION

MACHINERY OVERSPEED

Some motors and/or loads may not be suited for operation above nameplate motor speed and frequency. Consult motor manufacturer before operating motor above rated speed.

Failure to follow this instruction can result in injury or equipment damage.

- The drive controller is incapable of producing additional output voltage when operating above the nominal output frequency (generally 50/60 Hz). When operating above the nominal output frequency, the available continuous motor torque will begin to decrease along with the motor maximum overtorque capability. Consult the motor manufacturer for continuous and overtorque torque capabilities of the particular motor.

Regenerative Operation

A dynamic braking kit must be installed if regenerative torque is required. Overcurrent capability in the regenerative mode is similar to overcurrent in the motoring mode. For continuous regeneration applications, consult the factory. For C10 through C19 controllers, a “B” suffix is required for dynamic braking operation.

Driving Torque Production Envelope

Figures 33 and 34 illustrate typical continuous torque and overcurrent driving capability for a typical NEMA Design B, 1.0 service factor motor with constant torque (Figure 33) and variable torque (Figure 34) loads.

For 1.15 service factor motors, the continuous torque rating is 1.0 times the motor rated torque value from 50 to 100% of motor nameplate rated speed.

- Normal (constant torque and variable torque) and High Torque (constant torque) control types:
 - 100% torque typical at 50% of nominal frequency (over 2:1 speed range)
 - Torque decreases linearly to 50% at 0.1 Hz
- Transient overcurrent, typical $\pm 10\%$:
 - ATV66U41N4 to D12N4 and ATV66U41M2 to D12M2: 170% torque for 60 s (constant torque); 110% torque for 60 s (variable torque).

- ATV66D16N4 to C31N41 and ATV66D16M2 to D46M2: 150% torque for 60 s (constant torque); 110% torque for 60 s (variable torque).
- Special (constant torque) and NOLD (variable torque) control types:
 - 100% torque typical at 50% of nominal frequency (over 2:1 speed range)
 - Torque decreases linearly to 50% at 10% of nominal frequency
 - Transient overtorque, typical $\pm 10\%$:
ATV66U41N4 to C31N41 and ATV66U41M2 to D46M2: 150% torque for 60 s (constant torque); 110% torque for 60 s (variable torque).

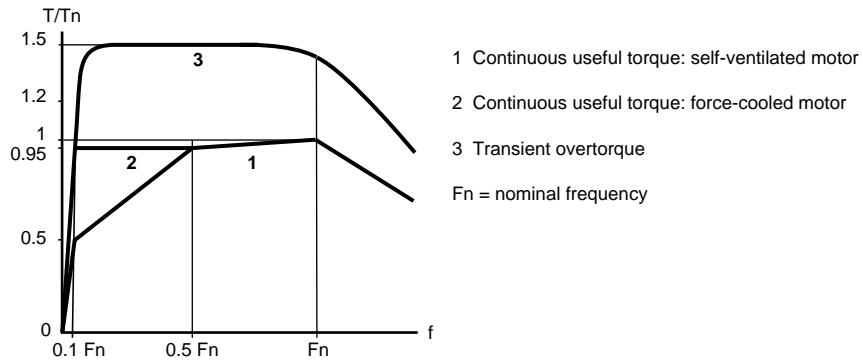

Figure 33: Typical Constant Torque Curves

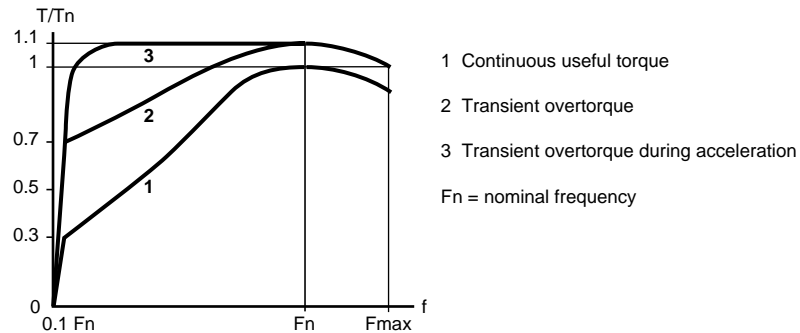

Figure 34: Typical Variable Torque Curves

MOTOR CONSIDERATIONS

Many factors must be considered when controlling a motor with a drive controller. The following sections describe several drive controller characteristics as they relate to motor protection and performance.

Motor Insulation

ALTIVAR 66 drive controllers use pulse width modulation. Verify that the motor insulation is designed for this modulation method.

Motors in Parallel

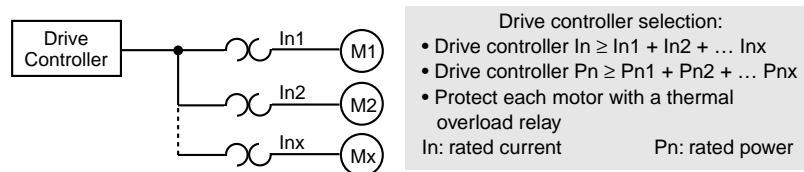

Figure 35: Motors in Parallel

To operate motors in parallel, use the keypad display to set the Control Type to "Normal." When motors are in parallel, slip compensation is not at the optimum level. If the load is to be shared between the motors, disable the slip compensation. For information on adjusting and disabling parameters, see the Level 1 & 2 Configuration Manual.

If three or more motors are to be installed in parallel, consult factory.

Output Contactor Between Motor and Drive Controller

When using an output contactor between the drive controller and motor, use of the Bypass application function is recommended. In order to set the motor parameters for optimum performance, the motor must be directly connected to the output of the drive controller at least one time during drive controller power-up. For more information, refer to the Level 1 & 2 Configuration manual.

Additional Motor Connected Downstream of the Drive Controller

When connecting an additional motor, comply with the recommendation for "Motors in Parallel."

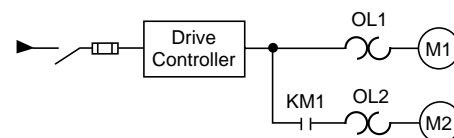

Figure 36: Connecting an Additional Motor

If the motor will be connected to the drive controller while the drive controller is running, the sum of the running motor current(s) plus the expected starting current of the switched motor must not exceed 90% of the drive controller's transient output current rating.

Using a Synchronous Permanent Magnet or Wound-Field Motor

It is possible to operate a synchronous permanent magnet or synchronous wound-field motor as long as the following conditions are met:

- Slip compensation is disabled.
- Internal overload protection is disabled and external protection (overload relay or thermal sensor) is used.
- Operation is only with Special control type with constant torque setting.
- Appropriate field excitation and protection is provided for externally-excited motors.

Using a Synchronous Reluctance Motor

It is possible to operate a synchronous reluctance motor as long as slip compensation is disabled.

Table 29: Operating Non-Standard Motors

Description	Slip Compensation	Overload	Control Type
Motors in parallel	Disable	Disable ^[1]	Special
Additional motor	Enable	Disable ^[1]	Special
Synchronous permanent magnet	Disable	Disable ^[1]	Special
Synchronous wound field	Disable	Disable ^[1]	Special
Synchronous reluctance	Disable	Enable	Special

^[1] An external thermal overload relay is required if the drive controller protection is disabled.

CHAPTER 4—DIAGNOSTICS

PRECAUTIONS	78
PROCEDURE 1: BUS VOLTAGE MEASUREMENT	78
PROCEDURE 2: INPUT LINE VOLTAGE MEASUREMENT	81
PROCEDURE 3: CHECKING PERIPHERAL EQUIPMENT	81
PROCEDURE 4: IDENTIFYING THE FIRMWARE VERSION	82
Power On Procedure	82
Alternate Procedure	82
PREVENTIVE MAINTENANCE	83
RESETTABLE/RENEWABLE PARTS	84
Resettable Parts	84
Renewable Parts	84
F4A, F4B & F4C Bus Fuse Test Procedure: ATV66C23N41 to ATV66C31N41	85
LEDS	88
FAULT MESSAGES	88

PRECAUTIONS

Read the safety statement below before proceeding with any maintenance or troubleshooting procedures.

Tables 30 and 31 on pages 88-92 list fault messages (displayed on the keypad display), probable causes or faults, and associated corrective action. Before taking corrective action, remove all power and check the bus voltage (Procedure 1), input line voltage (Procedure 2 on page 81), and peripheral equipment (Procedure 3 on page 81).

DANGER

HAZARDOUS VOLTAGE

Read and understand these procedures before servicing ALTIVAR 66 drive controllers. Installation, adjustment, repair, and maintenance of these drive controllers must be performed by qualified personnel.

Failure to follow these instructions will result in death or serious injury.

PROCEDURE 1: BUS VOLTAGE MEASUREMENT

DANGER

HAZARDOUS VOLTAGE

- This equipment contains energy storage devices. Read and understand Bus Voltage Measurement Procedure before performing procedure. Measurement of DC bus capacitor voltage must be performed by qualified personnel.
- DC bus LED is not an accurate indication of absence of DC bus voltage.
- DO NOT short across capacitors or touch unshielded components or terminal strip screw connections with voltage present.
- Many parts in this drive controller, including printed wiring boards, operate at line voltage. DO NOT TOUCH. Use only electrically insulated tools.

Failure to follow these instructions will result in death or serious injury.

The PA and – terminals are located inside the drive controller (see Figure 37). To measure the bus capacitor voltage:

1. Disconnect and verify all power is removed from drive controller.
2. Wait 1 minute to allow the DC bus to discharge.
3. Open the front cover of the drive controller.
4. Set the voltmeter to the 1000 VDC scale. Measure the bus capacitor voltage between the PA and – terminals to verify the DC voltage is less than 45 V. **Do not short across capacitor terminals with voltage present!**

- If the bus capacitors are not fully discharged, contact your local representative. **Do not operate the drive controller.**

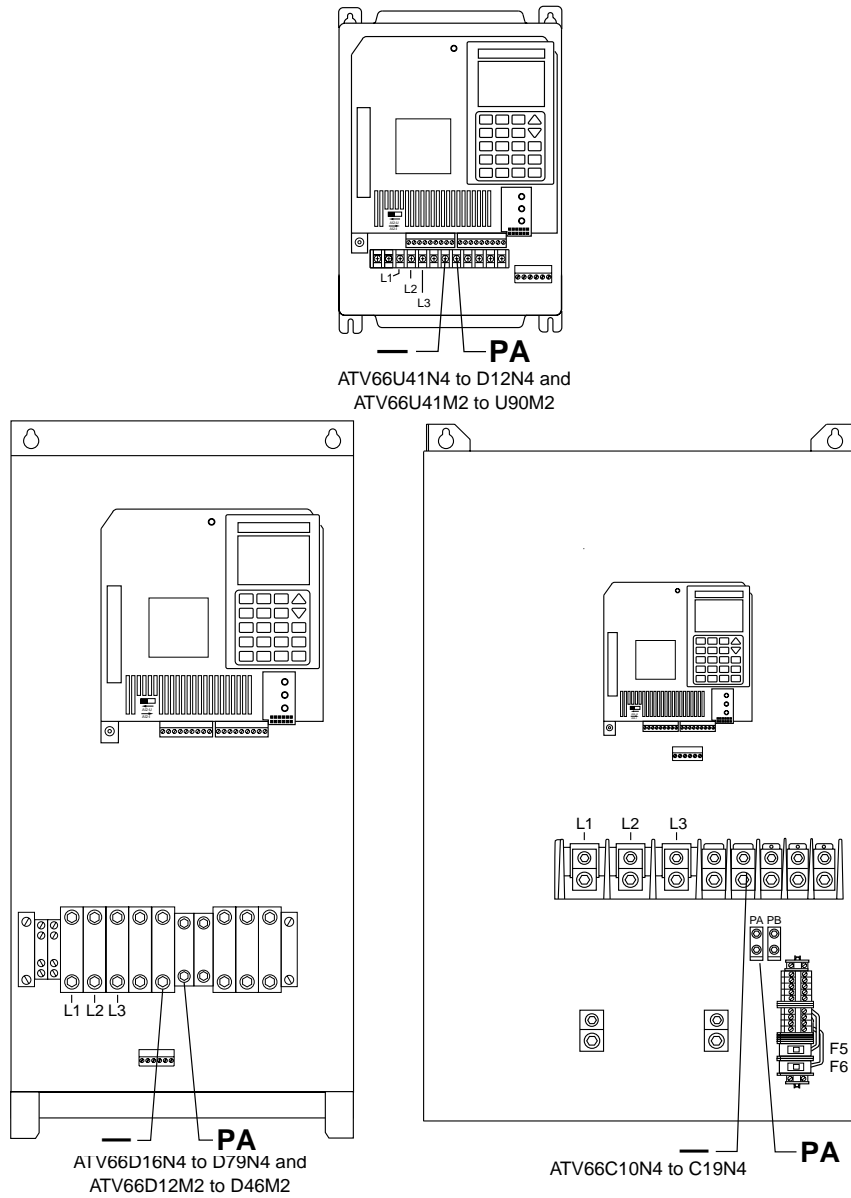

Figure 37: Location of PA and - Terminals: ATV66U41N4 to C19N4 and ATV66U41M2 to D46M2

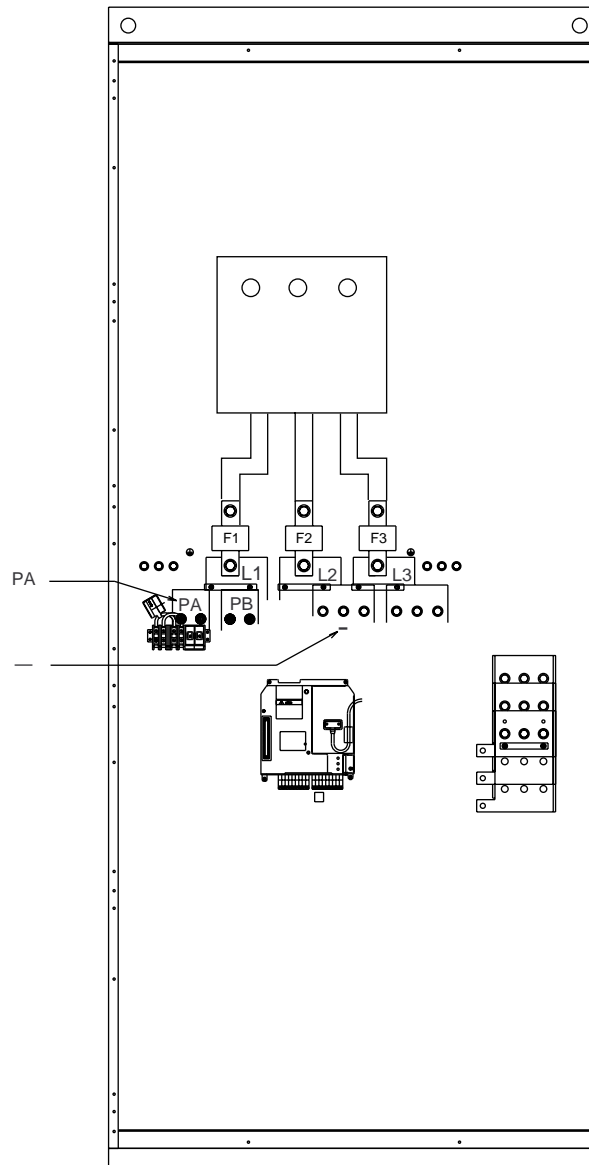

Figure 38: Location of PA and - Terminals: ATV66C23N41 to C31N41

PROCEDURE 2: INPUT LINE VOLTAGE MEASUREMENT

To measure the input line voltage:

1. Perform Bus Voltage Measurement procedure (see page 78).
2. Set voltmeter to the 600 VAC scale. Attach meter leads to L1 and L2.
3. Reapply power and check for correct line voltage, per drive controller nameplate rating.
4. Remove power and repeat procedure for L2 and L3, and L1 and L3.
5. When all phases have been measured, remove power. Remove meter leads and reinstall covers.

PROCEDURE 3: CHECKING PERIPHERAL EQUIPMENT

You may need to check the following equipment. If you do, please follow the manufacturer's procedures.

1. A protective device such as a fuse or circuit breaker may have opened.
2. A switching device such as a contactor may not be closing at the correct time.
3. Conductors may require repair or replacement.
4. Connection of cables to the motor or connections to ground may need to be checked. Follow NEMA standard procedure WC-53.
5. Motor insulation may need to be checked. Follow NEMA standard procedure MG-1. Do not apply high voltage to drive controller output terminals (U/T1, V/T2 or W/T3). Do not connect high potential dielectric test equipment or insulation resistance tester to the drive controller since the test voltages utilized may damage the drive controller. Always disconnect the drive controller from the conductors or motor while performing such tests.

PROCEDURE 4: IDENTIFYING THE FIRMWARE VERSION

Power On Procedure

1. With the drive controller powered up, press the ESC key one or more times to access the Drive Identification screen.
2. Read the firmware version from the upper right corner of the Drive Identification screen.

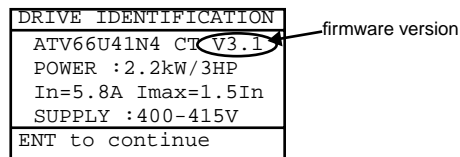



Figure 39: Drive Identification Screen

 **DANGER**

HAZARDOUS VOLTAGE

- Read, understand, and perform “Procedure 1: Bus Voltage Measurement” on page 78 before identifying the firmware version. Measurement of DC bus capacitor voltage must be performed by qualified personnel.
- The DC bus LED is not an accurate indication of absence of DC bus voltage.
- DO NOT short across capacitors or touch unshielded components or terminal strip screw connections with voltage present.
- Many parts in this drive controller, including printed wiring boards, operate at line voltage. DO NOT TOUCH. Use only electrically insulated tools.

Failure to follow these instructions will result in death or serious injury.

Alternate Procedure

1. Disconnect and verify that all power is removed from the drive controller (including any power present on J22, J23 & J24 terminals of the I/O extension module, if installed).
2. Wait 1 minute to allow the DC bus to discharge.
3. Perform the Bus Voltage Measurement Procedure listed above in this chapter.
4. Insert a small, electrically-insulated screw driver in the notch of the firmware chip cover. Apply slight upward pressure and pull out to remove the cover. See Figure 40.

NOTE: If the drive controller is equipped with an I/O extension module or communication carrier module, first remove the module by loosening the

two mounting screws. (On the I/O extension module, also unplug the separable connectors J22, J23 & J24 from the bottom of the module.)

5. Record the firmware revision number from the chip.
6. Replace the plastic cover over the firmware chip.
7. Reinstall the module (as required, see note in Step 4).
8. Close the drive controller cover.

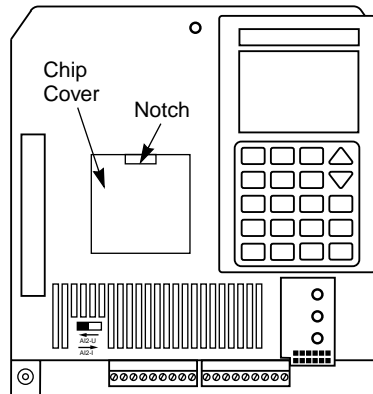

Figure 40: Main Control Board — Location of Chip Cover

PREVENTIVE MAINTENANCE

Before performing preventive maintenance, remove all power and check the bus voltage (Procedure 1 on page 78).

The following preventive maintenance procedures are recommended at regular intervals:

- Check the condition and tightness of the connections.
- Make sure the ventilation is effective and temperature around the drive controller remains at an acceptable level.
- Remove dust and debris from the drive controller, if necessary.

If anything unusual occurs when putting the drive controller into service or during operation, be sure all recommendations relating to the environment, mounting, and connection of the drive controller have been followed.

RESETTABLE/RENEWABLE PARTS

The ATV66U41N4 to D79N4 and ATV66U41M2 to D46M2 drive controllers contain no resettable or renewable parts. The ATV66C10N4 to C31N41 drive controllers contain the following resettable or renewable parts. Refer to pages 79 and 80 for their location.

Resettable Parts

- Protective Switch (GV2) for precharge resistor. (Note: ATV66C23N41 to ATV66C31N41 drive controllers have two protective switches.) A tripped switch is displayed as a Precharge fault. Perform Bus Voltage Measurement procedure on page 78 before resetting switch. If switch trips, operations of the KM1 contactor or disconnect means may have exceeded one per every two minutes as recommended on page 58. Prior to resetting the switch, check number of operations of the KM1 contactor. A tripped switch may also be caused by a short circuit on the DC bus. In this case, drive controller may require servicing.

Renewable Parts

- Line power fuses (F1-F3). Refer to page 64 for information on mounting and replacing these fuses. See Appendix A — Spare Parts List for replacement fuses.
- Control fuses (F5, F6). Perform Bus Voltage Measurement procedure on page 78. The control fuses are contained in a removable clip. To access fuses, pull clip out of the fuse holder. Replace with KTK-R-5 fuses or use DF3CF00501 control fuse kit.
- DC bus fuses F4A, F4B, and F4C on ATV66C10N4 to C31N41 drive controllers. Before checking fuse, perform the following Bus Fuse Test Procedures:



HAZARDOUS VOLTAGE

- This equipment contains energy storage devices. Read and understand the F4A, F4B & F4C bus fuse test procedure before performing this procedure. Measurement of DC bus capacitor voltage must be performed by qualified personnel.
- DC bus LED is not an accurate indication of absence of DC bus voltage.
- DO NOT short across capacitors or touch unshielded components or terminal strip screw connections with voltage present.
- Many parts in this drive controller, including printed wiring boards, operate at line voltage. DO NOT TOUCH. Use only electrically insulated tools.

Failure to follow these instructions will result in death or serious injury.

F4A, F4B, and F4C Bus Fuse Test Procedure: ATV66C10N4 to ATV66C31N41

Be sure to check the serial number on your drive controller to determine if this procedure applies to the model you are testing. **If the seventh digit of the serial number is not a “1”, do not follow this procedure.** Instead, consult the receiving and installation manual that was shipped with the drive controller, or the ALTIVAR 66 Drive Controller Service and Troubleshooting Manual, bulletin number VD0C06S701_.

The PA and (-) terminals are located inside the drive controller (see Figures 41 and 42). To measure the bus capacitor voltage and voltage at the fuse:

1. Disconnect and verify all power is removed from the drive controller.
2. Wait one minute to allow the DC bus to discharge.
3. Open the front cover of the drive controller.
4. Set the voltmeter to the 1000 VDC scale. Measure the bus capacitor voltage between the PA and (-) terminals to verify the DC voltage is less than 10 V. **Do not short across capacitor terminals with voltage present.**
5. If the bus capacitors are not fully discharged, contact your local representative—**do not operate the drive controller.**
6. Measure the voltage between the (-) terminal and U/T1, V/T2, and W/T3 terminals to verify the voltage is less than 10 V.
7. If the voltage is not less than 10 V, contact your local representative—**do not operate the drive controller.**
8. Disconnect the motor leads from the U/T1, V/T2, and W/T3 terminals of the drive controller. Mark leads to facilitate correct replacement to terminals.
9. Using a multimeter equipped with a diode junction test function (Fluke Model 87 Multimeter or equivalent), perform the following measurements to determine the condition of fuses F4A, F4B, and F4C:
 - a. Using the diode test function, check circuit continuity between U/T1 terminal to (-) terminal. Continuity should be present for either polarity of the measurement. Lack of continuity in one direction is an indication that fuse F4A is open.
 - b. Using the diode test function, check circuit continuity between V/T2 terminal to (-) terminal. Continuity should be present for either polarity of the measurement. Lack of continuity in one direction is an indication that fuse F4B is open.
 - c. Using the diode test function, check circuit continuity between W/T3 terminal to (-) terminal. Continuity should be present for either polarity of the measurement. Lack of continuity in one direction is an indication that fuse F4C is open.

10. If any of the fuses are open, this indicates that other components may be damaged. **Do not attempt replacement. Contact your local representative.**
11. Reconnect the motor leads to the U/T1, V/T2, and W/T3 terminals of the drive controller.

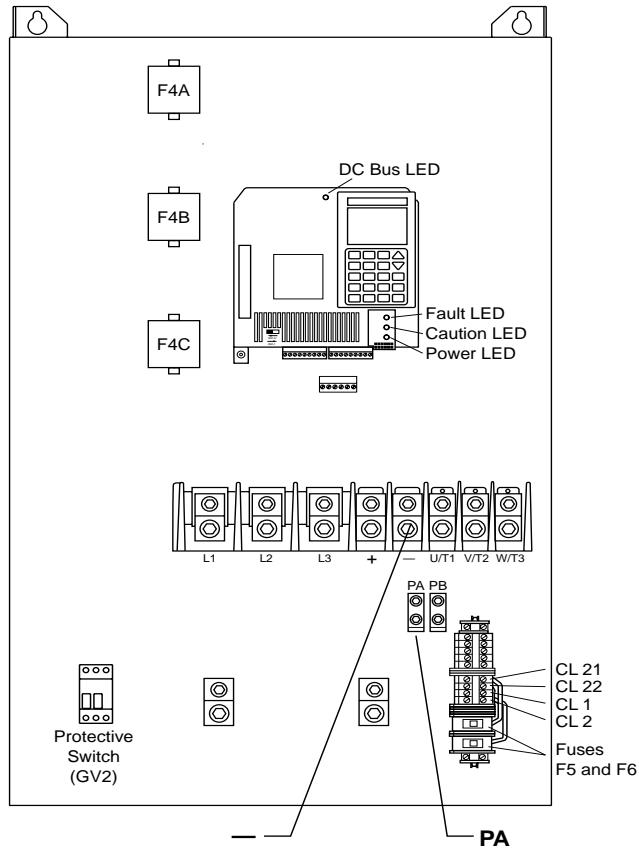

Figure 41: F4A, F4B, F4C Bus Fuse Test Procedure: ATV66C10N4 to C19N4

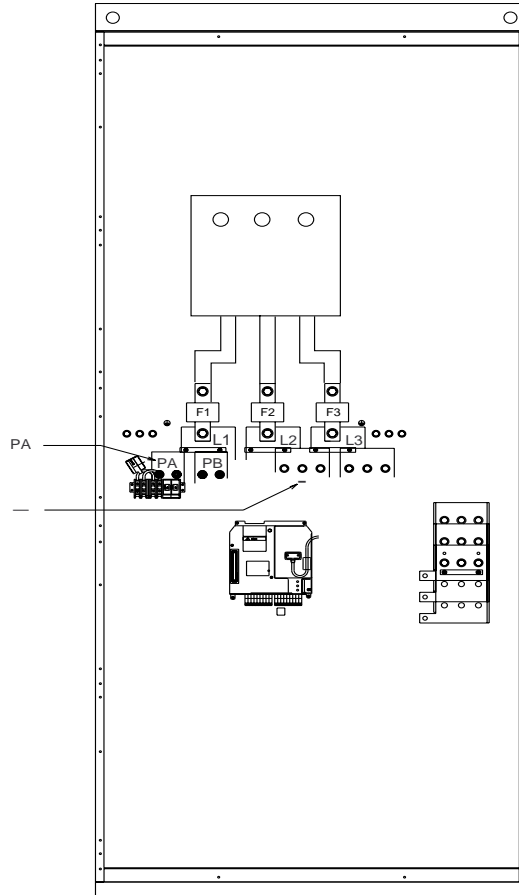

Figure 42: F4A, F4B, F4C Bus Fuse Test Procedure: ATV66C23N41 to C31N41

LEDS

The LEDs on the front of the drive controller indicate the following:





<p>FAULT (Red)</p> 	<p>Illuminated: Fault exists.</p>	
<p>CAUTION (Yellow)</p> 	<p>Illuminated with Fault LED OFF: Drive controller is running and in current limit or ramp modification. <i>NOTE: LED may appear to flash rapidly as drive controller regulates at current limit or ramp modification.</i> Slow Flashing with Fault LED OFF: This Pre-Alarm indicates either a Drive Overtemperature Fault (ATV66D12M2 to D46M2 or ATV66D16N4 to C31N41 only) or a Motor Overload Fault. Consult Keypad Display for Motor Thermal State or Drive Thermal State (ATV66D12M2 to D46M2 or ATV66D16N4 to C31N41 only) to determine which condition is causing the Pre-Alarm. If either of these thermal states exceeds 100%, the Caution LED will flash slowly. Illuminated with Fault LED ON: Drive controller fault exists on either Motor Overload or Drive Overtemperature and the cool-down period has not yet expired. Consult the fault display on the keypad or the fault history in Menu 3 to determine the most recent fault.</p>	
<p>POWER (Green)</p> 	<p>Illuminated: Drive controller is powered; DC bus ≥ 50 V or voltage is present at CL1-CL2.</p>	<p><i>For locations of LEDs, see pages 41, 42, and 43.</i></p>
<p>DC BUS (RED)</p> 	<p>Illuminated: DC bus ≥ 50 V</p>	

Figure 43: Drive Controller LEDs

FAULT MESSAGES

The ALTIVAR 66 drive controller can store up to eight faults and display them as messages on the keypad display. These fault messages, listed in Table 30, allow access to Fault History Screens, which display the drive controller run status at the time of each fault. For more information on Fault History Screens, see the Level 1 & 2 Configuration Manual.

For more information on troubleshooting, see the ATV66 Service and Troubleshooting Manual (instruction bulletin VD0C06S701_), available through a Square D distributor.

Table 30: Fault Messages

Fault Message	Probable Cause	Troubleshooting Procedure
(Display off or partial display)	<ol style="list-style-type: none"> No control supply. Control voltage too low. 	<ol style="list-style-type: none"> Check input line voltage (Procedure 2 on page 81). Check fuses and circuit breaker (Procedure 3 on page 81). Check CL1-CL2 control terminal connections.
<p>[1] This fault always causes a freewheel stop. [2] This occurs only on power up.</p>		

Table 30: Fault Messages (Continued)

Fault Message	Probable Cause	Troubleshooting Procedure
IN-PHASE LOSS (Input phase loss)	<ol style="list-style-type: none"> No supply to terminals L1-L2-L3. Power fuses open. Brief input line failure ($t \geq 200$ ms). Internal connections. 	<ol style="list-style-type: none"> Check input line voltage (Procedure 2 on page 81). Check fuses and circuit breaker (Procedure 3 on page 81). Reset drive controller. Check connections.
UNDERVOLTAGE ^[1]	<ol style="list-style-type: none"> Supply too low: $V \leq 380$ V (ATV66...N4) $V \leq 170$ V (ATV66...M2) Temporary voltage drop ($t \geq 200$ ms). Internal connections. 	<ol style="list-style-type: none"> Check input line voltage (Procedure 2 on page 81). Check Nominal Motor Voltage parameter (see Level 1 & 2 Configuration Manual). Reset drive controller. Check connections.
AC-LIN. OVERVOL ^[1] (AC Line Overvoltage)	<ol style="list-style-type: none"> Supply too high: $V \geq 550$ V (ATV66...N4) $V \geq 270$ V (ATV66...M2) 	<ol style="list-style-type: none"> Check input line voltage (Procedure 2 on page 81). Check Nominal Motor Voltage parameter (see Level 1 & 2 Configuration Manual).
DC-BUS OVERVOL ^[1] (DC Bus Overvoltage)	<ol style="list-style-type: none"> Overvoltage or overcurrent due to excessive braking or an overhauling load (even with braking option). 	<ol style="list-style-type: none"> Increase deceleration time. Add braking option if necessary. Reset is possible if line voltage ≤ 550 V.
OVERTEMP DRIVE (Drive Overtemperature)	<ol style="list-style-type: none"> Heat sink temperature too high 	<ol style="list-style-type: none"> Check motor load, fan and ambient temperature around drive controller. Wait for drive controller to cool down before resetting.
MOT. OVERLOAD (Motor Overload)	<ol style="list-style-type: none"> If thermal trip setting is $\geq 118\%$ of normal thermal state (109% of nominal current), thermal trip is due to prolonged overload or output phase failure. Motor power rating too low for application. 	<ol style="list-style-type: none"> Check setting of MOT. OVERLOAD parameter and compare with motor In. Check load and compare with operating speed. Check braking conditions (possibility of single phase operation). Wait approximately 7 minutes before resetting. Verify motor and drive controller selection is correct for application. For motors with continuous current rating less than 50% of drive controller current rating, see Level 1 & 2 Configuration Manual.

^[1] This fault always causes a freewheel stop.

^[2] This occurs only on power up.

Table 30: Fault Messages (Continued)

Fault Message	Probable Cause	Troubleshooting Procedure
<p>SHORT CIRCUIT ^[1]</p> <p>Screen showing "Short Circuit" with "*" means LIC exceeded</p> <p>Screen showing "Short Circuit" with no other symbol means desaturation</p>	<ol style="list-style-type: none"> Short circuit or grounding on drive controller output. (Short Circuit* or Short Circuit) Internal drive fault. (Short Circuit) Motor improperly applied. (Short Circuit*) 	<ol style="list-style-type: none"> Remove all power. With drive controller disconnected, check connecting cables and motor insulation. Use drive controller self-diagnostics. See Level 1 & 2 Configuration Manual. See "Motor Considerations" on page 74.
PRECHARGE FAIL ^[2]	<ol style="list-style-type: none"> Capacitor charge relay closure control fault. For ATV66C10N4-C31N41, tripped protective switch (GV2). 	<ol style="list-style-type: none"> Check connections in drive controller after following Bus Voltage Measurement Procedure (see page 78). Reset switch after following Bus Voltage Measurement Procedure (see page 84).
SERIAL LINK	<ol style="list-style-type: none"> Serial link communication fault. 	<ol style="list-style-type: none"> Check connections between drive controller and keypad, computer and/or programmable controller.
INTERNAL FAULT ^[1]	<ol style="list-style-type: none"> Internal connection fault. Missing connections on CL1 and CL2. 	<ol style="list-style-type: none"> Check internal connections after following Bus Voltage Measurement procedure (see page 78).
LOSS FOLLOWER	<ol style="list-style-type: none"> Loss of 4-20 mA signal on AI2 input. 	<ol style="list-style-type: none"> Verify signal connections. Check signal.
GROUND FAULT ^[1]	<ol style="list-style-type: none"> Short circuit of phase to earth or grounding on the output of the drive controller. 	<ol style="list-style-type: none"> Remove all power. With drive controller disconnected, check connecting cables and motor insulation. Use drive controller diagnostics. See Level 1 & 2 Configuration Manual.
MEMORY FAILURE ^[2]	<ol style="list-style-type: none"> EEPROM memory storage fault. 	<ol style="list-style-type: none"> Recall factory or customer settings with keypad.
AUTO-TEST FAIL ^[2]	<ol style="list-style-type: none"> Main control board failure. 	<ol style="list-style-type: none"> Remove all power. Check control board connections with drive controller disconnected. Replace main control board.
CONTROL SUPPLY ^[2]	<ol style="list-style-type: none"> CL1/CL2 not connected. 	<ol style="list-style-type: none"> Check connection of CL1 and CL2.
OVERSPEED	<ol style="list-style-type: none"> Output frequency is 20% above Maximum Frequency parameter setting (no tachometer present). 	<ol style="list-style-type: none"> Check load base speed and power rating, compare with operating speed and drive controller/motor power rating. Check setting of output and bandwidth (if used) adjustments.

^[1] This fault always causes a freewheel stop.

^[2] This occurs only on power up.

Table 30: Fault Messages (Continued)

Fault Message	Probable Cause	Troubleshooting Procedure
DYNAMIC BRAKE	<ol style="list-style-type: none"> 1. DB transistor short circuit. 2. DB resistor short or open circuited. 3. Braking resistor thermal contact tripped. 	<ol style="list-style-type: none"> 1. Remove all power. Check connecting cables and DB resistor with drive controller disconnected. 2. Use drive controller self-diagnostics. See Level 1 & 2 Configuration Manual. 3. Check dynamic brake connections. Change resistor if necessary.
DB RESISTOR	<ol style="list-style-type: none"> 1. DB resistor overload. 	<ol style="list-style-type: none"> 1. Increase deceleration time. Reset drive controller. 2. Increase DB resistor power rating.
LINK FAULT	<ol style="list-style-type: none"> 1. Internal fault 2. Software execution stopped 	<ol style="list-style-type: none"> 1. Note LED sequence on drive controller: — FAULT, CAUTION, POWER all illuminated, or — CAUTION, POWER illuminated 2. Cycle power. 3. If fault persists, replace keypad or main control board.
SEQUENCE T. OUT (Sequence Time out)	<ol style="list-style-type: none"> 1. Sequence input not received after Run command within programmed time (Bypass function). 	<ol style="list-style-type: none"> 1. Check connection between user-supplied contact and logic input, ensuring it is connected to programmed input. 2. Verify operation of contact. 3. Verify operation of external control sequencing.
PROCESS TIME OUT	<ol style="list-style-type: none"> 1. Process input not received after Run command within programmed time (Bypass function). 	<ol style="list-style-type: none"> 1. Check connection between user-supplied contact and logic input, ensuring it is connected to programmed input. 2. Verify operation of contact. 3. Verify operation of process.
TRANS. SHORT C. OR GF (Transistor Short Circuit)	<ol style="list-style-type: none"> 1. Transistor is in short circuit. 	<ol style="list-style-type: none"> 1. Contact local service representative.
OPEN TRANSISTOR	<ol style="list-style-type: none"> 1. Transistor has failed open. 	<ol style="list-style-type: none"> 1. Contact local service representative.
OUT PHASE LOSS	<ol style="list-style-type: none"> 1. Motor power ratio too small for controller. 2. Output phase disconnected. 	<ol style="list-style-type: none"> 1. Motor power rating must be > 45% of controller power rating. 2. Check output power conductors, load disconnect or contactors for lack of continuity. 3. Check output contactor sequence.

[1] This fault always causes a freewheel stop.

[2] This occurs only on power up.

The additional faults listed in Table 31 may be displayed if an option module is installed and a fault occurs.

Table 31: Fault Messages from Option Modules

Fault Messages	Probable Cause	Troubleshooting Procedure
Without tachometer:		
OVERSPEED	1. Output frequency is 20% above Maximum Frequency parameter setting.	1. Check load base speed and power rating, compare with operating speed and drive controller/motor power rating.
With tachometer:		
	1. Incorrect adjustment of tachometer feedback.	1. Check feedback.
	2. Machine overload.	2. Check load base speed and power rating, compare with operating speed and drive controller/motor power rating.
	3. No tachometer signal.	3. Check tachometer connection.
	4. Tachometer polarity incorrect.	4. Check tachometer polarity.
CUSTOM. FAULT	1. User defined.	1. Dependent on user setting.
FEEDBACK LOSS	1. No tachometer feedback signal.	1. Check tachometer wiring.

Other faults may be displayed depending on how the drive controller is programmed. For more information on faults and self-diagnostics, refer to Level 1 & 2 Configuration Manual.

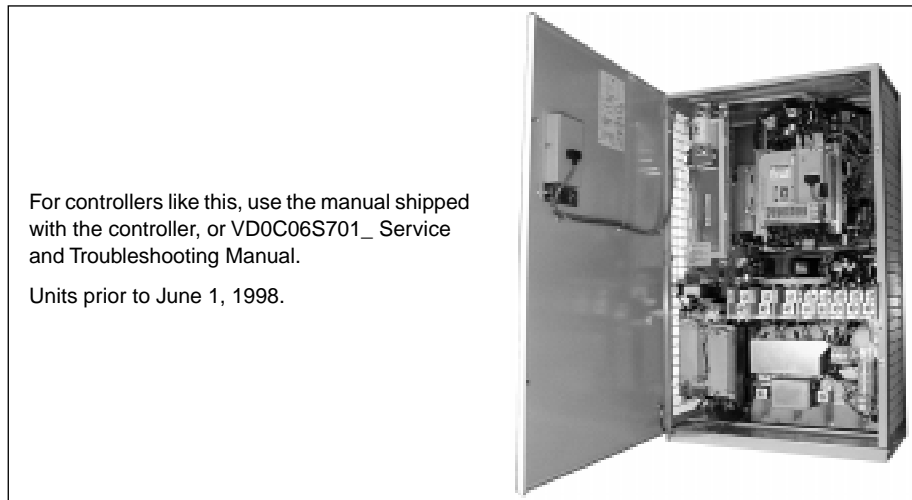

Figure 44: ATV66C10N4 to ATV66C19N4

APPENDIX A—SPARE PARTS LIST

Replacement of spare parts requires the use of special tools and installation procedures not included with the spare parts kits. Before replacing any spare part, consult the ALTIVAR 66 Drive Controller Service and Troubleshooting Manual, bulletin number VD0C06S701_. This manual can be ordered from your local Square D distributor. Spare parts must be removed and installed only by qualified electrical personnel familiar with the Service and Troubleshooting manual.

When ordering spare parts for the ATV66C10N4 to ATV66C19N4 drive controllers, follow this guideline:

- If the drive controller serial number has a “1” as the seventh digit, this table can be used to select spare parts. All controllers shipped after May 1998 should have a “1” as the seventh digit.
- If the drive controller serial number does **not** have a “1” as the seventh digit, consult the Receiving and Installation manual that was shipped with the drive controller or the ALTIVAR 66 Drive Controller Service and Troubleshooting Manual, bulletin number VD0C06S701_.
- See Figures 44 and 45.

Use the spare parts list in this appendix for all other drive controller models (ATV66U41N4 to D79N4, ATV66U41M2 to D46M2, and ATV66C23N41 to C31N41).

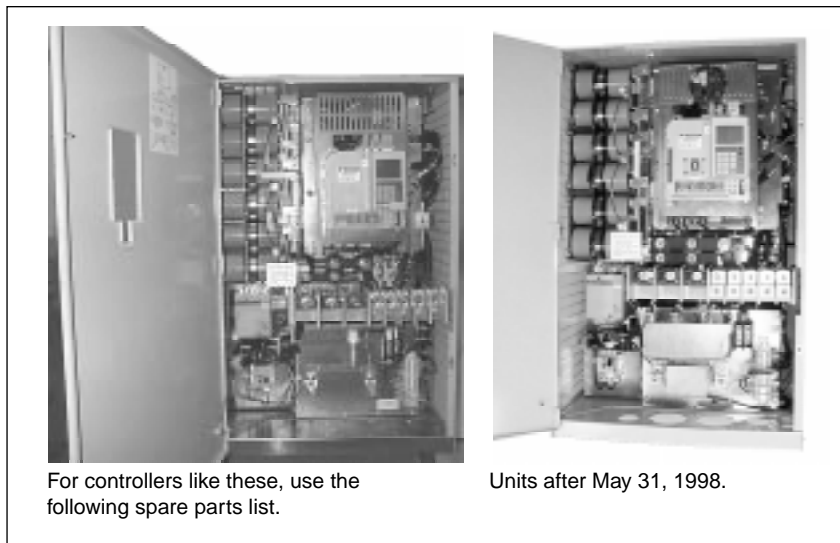

Figure 45: ATV66C10N4 to ATV66C19N4

Table 32: Spare Parts List

Description	Drive Controller	Reference No.	Note
ALTIVAR 66 Adjustable Frequency Drive Controller Service and Troubleshooting Manual	ATV66 all sizes	VD0C06S701_	
Control Kit — 460 V	ATV66U41N4 to D79N4 ATV66C10N4 to C31N41	VX4A66CK1 VX4A66CK2	Matched keypad and control basket with latest firmware
Control Kit — 208/230 V	ATV66U41M2 to D46M2* *ATV66D23M2S264U	VX4A66CK1 VX4A66CK1S260	Matched keypad and control basket with latest firmware
Keypad display (for drive controllers with firmware level 3.0 and later — see Chapter 4 section "Identifying the Firmware Version")	ATV66 all sizes	VW3A66206U	For drive controllers with firmware earlier than 3.0, order the control kit listed above
Removable Control Terminal Strips	ATV66 all sizes	VZ3N006	J1, J12 and J13 on control basket
Power Board — 460 V	ATV66U41N4 (Serial number ends in code "A21" and earlier — see Chapter 1 section "Nameplates and Serial Numbers")	VX5A66U41N4	Includes IGBT block, rectifier diode, heatsink, and fan
	ATV66U41N4 (Serial number ends in code "A22" and later — see Chapter 1 section "Nameplates and Serial Numbers")	VX5A663U41N4	Includes IGBT block and rectifier diode
	ATV66U54N4	VX5A662U54N4	Includes IGBT block and rectifier diode
	ATV66U72N4	VX5A662U72N4	Includes IGBT block and rectifier diode
	ATV66U90N4	VX5A662U90N4	Includes IGBT block and rectifier diode
	ATV66D12N4	VX5A662D12N4	Includes IGBT block and rectifier diode
	ATV66D16N4	VX5A66D16N4	
	ATV66D23N4	VX5A66D23N4	
	ATV66D33N4	VX5A66D33N4	
	ATV66D46N4	VX5A66D46N4	
	ATV66D54N4	VX5A66D54N4	
	ATV66D64N4	VX5A66D64N4	
	ATV66D79N4	VX5A66D79N4	
	ATV66C10N4	VX5A661C10N4	
	ATV66C13N4	VX5A661C13N4	
	ATV66C15N4	VX5A661C15N4	
	ATV66C19N4	VX5A661C19N4	
	ATV66C23N41	VX5A661C23N4	
	ATV66C28N41	VX5A661C28N4	
	ATV66C31N41	VX5A661C31N4	

Table 32: Spare Parts List (Continued)

Description	Drive Controller	Reference No.	Note
Power Board — 208/230 V	ATV66U41M2	VX5A662U41M2	Includes IGBT block and rectifier diode
	ATV66U72M2	VX5A662U72M2	Includes IGBT block and rectifier diode
	ATV66U90M2	VX5A662U90M2	Includes IGBT block and rectifier diode
	ATV66D12M2	VX5A66D12M2	
	ATV66D16M2	VX5A66D16M2	
Power Board and Gate Driver Board — 208/230 V	ATV66D23M2	VX5A66D234M2	Matched set
	ATV66D33M2	VX5A66D335M2	Matched set
	ATV66D46M2	VX5A66D466M2	Matched set
Gate Driver Board — 460 V	ATV66D16N4	VX5A66103	
	ATV66D23N4	VX5A66104	
	ATV66D33N4	VX5A66105	
	ATV66D46N4	VX5A66106	
	ATV66D54N4	VX5A66107	
	ATV66D64N4	VX5A66108	
	ATV66D79N4	VX5A66109	
Gate Driver Board — 208/230 V	ATV66D12M2	VX5A66112	
	ATV66D16M2	VX5A66113	
Inverter IGBT — 460 V	ATV66D16N4	VZ3IM2050M1201	1 dual IGBT block
	ATV66D23N4	VZ3IM2075M1201	1 dual IGBT block
	ATV66D33N4	VZ3IM2100M1201	1 dual IGBT block
	ATV66D46N4, D54N4	VZ3IM2150M1201	1 dual IGBT block
	ATV66D64N4	VZ3IM2200M1201	1 dual IGBT block
	ATV66D79N4	VZ3IM2300M1201	1 dual IGBT block
	ATV66C10N4	VZ3IM2300M1202	2 dual IGBT blocks, snubber boards, gate driver boards, 1 clamp module
	ATV66C13N4 to C19N4	VZ3IM2400M1202	2 dual IGBT blocks, snubber boards, gate driver boards, 1 clamp module
	ATV66C23N41, C28N41	VZ3IM1400M1207	4 dual IGBT blocks, snubber boards, gate driver boards
ATV66C31N41	VZ3IM1500M1207	4 dual IGBT blocks, snubber boards, gate driver boards	
Inverter IGBT — 208/230 V	ATV66D12M2	VZ3IM2075M0601	1 dual IGBT block
	ATV66D16M2	VZ3IM2100M0601	1 dual IGBT block
	ATV66D23M2	VZ3IM2150M0601	1 dual IGBT block
	ATV66D33M2	VZ3IM2200M0601	1 dual IGBT block
	ATV66D46M2	VZ3IM2300M0601	1 dual IGBT block
Inverter IGBT Clamp Capacitor	ATV66C23N41 to C31N41	VY1ADC610	

Table 32: Spare Parts List (Continued)

Description	Drive Controller	Reference No.	Note
Dynamic Braking IGBT — 460 V	ATV66D14N4, D23N4	VZ3IM1025M1001	
	ATV66D33N4, D46N4	VZ3IM2050M1201	
	ATV66D54N4	VZ3IM2100M1201	
	ATV66D64N4, D79N4	VZ3IM2150M1201	
	ATV66C10N4 to C19N4	VZ3IM1300M1202	1 dual IGBT block, 1 dual diode block, 1 snubber board, 1 gate driver board
	ATV66C23N41	VZ3IM1400M1208	1 dual IGBT block, 1 dual diode block, 1 snubber board, 1 gate driver board
	ATV66C28N41, C31N41	VZ3IM1300M1208	2 dual IGBT blocks, 2 dual diode blocks, 2 snubber boards, 1 gate driver board
Dynamic Braking IGBT — 208/230 V	ATV66D12M2, D16M2	VZ3IM1060M0601	
	ATV66D23M2	VZ3IM2075M0601	
	ATV66D33M2	VZ3IM2100M0601	
	ATV66D46M2	VZ3IM2150M0601	
Dynamic Braking Clamp Capacitor	ATV66C10N4 to C19N4	VY1ADC616	
	ATV66C23N41 to C31N41	VY1ADC614	
Line Filter Board — 460 V	ATV66D16N4, D23N4	VX4A66103	
	ATV66D33N4, D46N4	VX4A66104	
	ATV66D54N4 to D79N4	VX4A66105	
	ATV66C10N4 to C31N41	VX4A66106	
Line Filter Board — 208/230 V	ATV66D12M2, D16M2	VX4A66103	
	ATV66D23M2, D33M2	VX4A66104	
	ATV66D46M2	VX4A66105	
Line Rectifier Diode — 460 V	ATV66D16N4, D23N4	VZ3DM6075M1601	6-pack diode block
	ATV66D33N4	VZ3DM2080M1606	1 dual diode block
	ATV66D46N4	VZ3DM2100M1601	1 dual diode block
	ATV66D54N4 to D79N4	VZ3DM2160M1606	1 dual diode block
	ATV66C10N4, C13N4	VZ3DM2170M1602	1 dual diode block
	ATV66C15N4	VZ3DM2260M1602	1 dual diode block
	ATV66C19N4	VZ3DM2350M1602	1 dual diode block
	ATV66C23N41 to C31N41	VZ3DM2600M1602	1 dual diode block
Line Rectifier Diode — 208/230 V	ATV66D12M2, D16M2	VZ3DM6075M1601	6-pack diode block
	ATV66D23M2	VZ3DM2080M1606	1 dual diode block
	ATV66D33M2	VZ3DM2100M1601	1 dual diode block
	ATV66D46M2	VZ3DM2160M1606	1 dual diode block

Table 32: Spare Parts List (Continued)

Description	Drive Controller	Reference No.	Note
DC Bus Capacitor — 460 V	ATV66U41N4, U54N4	VY1ADC601	Assembly with capacitors
	ATV66U72N4	VY1ADC602	Assembly with capacitors
	ATV66U90N4	VY1ADC603	Assembly with capacitors
	ATV66D12N4	VY1ADC604	Assembly with capacitors
	ATV66D16N4, D23N4	VY1ADC152V450	One capacitor
	ATV66D33N4, D46N4	VY1ADC472V450	One capacitor
	ATV66D54N4	VY1ADC605	Assembly with capacitors and stirring fan
	ATV66D64N4, D79N4	VY1ADC606	Assembly with capacitors and stirring fan
	ATV66C10N4 to C19N4	VY1ADC615	Assembly with capacitors
ATV66C23N41 to C28N41	VY1ADC608	Assembly with capacitors	
DC Bus Capacitor — 208/230 V	ATV66U41M2	VY1ADC611	Assembly with capacitors
	ATV66U72M2	VY1ADC612	Assembly with capacitors
	ATV66U90M2	VY1ADC613	Assembly with capacitors
	ATV66D12M2, D16M2	VY1ADC152V450	One capacitor
	ATV66D23M2, D33M2	VY1ADC472V450	One capacitor
ATV66D46M2	VY1ADC605	Assembly with capacitors and stirring fan	
DC Bus Capacitor Bank Plexiglass Shield	ATV66C10N4 to C19N4	VY1ADV611	
Discharge Resistor — 460 V	ATV66D33N4 to D79N4	VZ3R5K0W040	One resistor
	ATV66C10N4 to C19N4	VZ3R2K5W600	Two resistors
	ATV66C23N41 to C31N41	VZ3R1K2W480	One resistor
Discharge Resistor — 208/230 V	ATV66D23M2 to D46M2	VZ3R5K0W040	One resistor
Precharge Resistor — 460 V	ATV66D16N4, D23N4	VZ3R033W009	One resistor
	ATV66D33N4, D46N4	VZ3R010W025	One resistor
	ATV66D54N4 to D79N4	VZ3R010W481	One resistor
	ATV66C10N4 to C31N41	VZ3R010W270	Two resistors
Precharge Resistor — 208/230 V	ATV66D12M2, D16M2	VZ3R033W009	One resistor
	ATV66D23M2, D33M2	VZ3R010W025	One resistor
	ATV66D46M2	VZ3R010W481	One resistor
Precharge Contactor — 460 V	ATV66D16N4, D23N4	LP4D1801BW3	
	ATV66D33N4	LC1D1801P7	
	ATV66D46N4	LC1D2501P7	
	ATV66D54N4, D64N4	LC1D4011P7	
	ATV66D79N4	LC1D6511P7	
	ATV66C10N4, C13N4	VY1A661C1010	
	ATV66C15N4, C19N4	VY1A661C1510	
ATV66C23N41 to C31N41	VY1A661C2310		
Precharge Contactor — 208/230 V	ATV66D12M2, D16M2	LP4D2500BW3	
	ATV66D23M2	LC1D3201P7	
	ATV66D33M2	LC1D5011P7	
	ATV66D46M2	LC1D4011P7	

Table 32: Spare Parts List (Continued)

Description	Drive Controller	Reference No.	Note
Precharge Contactor Auxiliary Contact Block	ATV66C10N4 to C31N41	LA1DN04	
Precharge Circuit Protector	ATV66C10N4 to C31N41	GV2M10	
Heatsink Fan — 460 V	ATV66U41N4, U54N4	VZ3V661	
	ATV66U72N4	VZ3V662	
	ATV66U90N4, D12N4	VZ3V663	
	ATV66D16N4, D23N4	VZ3V664	
	ATV66D33N4 to D79N4	VZ3V665	
	ATV66C10N4 to C19N4	VZ3V670	
Heatsink Fan — 208/230 V	ATV66C23N41 to C31N41	VZ3V666	
	ATV66U41M2	VZ3V662	
	ATV66U72M2, U90M2	VZ3V663	
	ATV66D12M2, D16M2	VZ3V664	
Stirring Fan — 460 V	ATV66D23M2 to D46M2	VZ3V665	
	ATV66D33N4 to D79N4	VZ3V6654	Power board fan
	ATV66D54N4 to D79N4	VZ3V6655	Capacitor bank fan
	ATV66C10N4 to C19N4	VZ3V671	
Stirring Fan — 208/230 V	ATV66C23N41 to C31N41	VZ3V669	
	ATV66D33M2 to D46M2	VZ3V6654	Power board fan
	ATV66D46M2	VZ3V6655	Capacitor bank fan
Fan Failure Detection Assembly	ATV66C23N41 to C31N41	VY1ADR100	Resistor and temperature switch
Power Supply for Overtemperature Detection Circuit	ATV66C23N41 to C31N41	VY1A66200	
Heatsink Temperature Sensor	ATV66D16N4 to D79N4	VZ3GN006	
	ATV66C10N4 to C31N41	VZ3GN005	
	ATV66D12M2 to D46M2	VZ3GN006	
Temperature Switch	ATV66C10N4 to C19N4	VZ3G007	Switch mounted on fuse bar
	ATV66C10N4 to C19N4	VZ3G008	Switch mounted on heatsink and motor current sensor
	ATV66C23N41 to C31N41	VZ3G004	One 68C switch, one 85C switch, heatsink mounted
Motor Current Sensor — 460 V	ATV66D33N4, D46N4	VY1A66104	2 sensors
	ATV66D54N4 to D79N4	VY1A66105	2 sensors
	ATV66C10N4, C13N4	VY1A66106	
	ATV66C15N4, C19N4	VY1A66107	
	ATV66C23N41 to C31N41	VY1A66108	
Motor Current Sensor — 208/230 V	ATV66D23M2	VY1A66104	2 sensors
	ATV66D33M2, D46M2	VY1A66105	2 sensors
Ground Fault Sensor — 460 V	ATV66D16N4, D23N4	VY1A66114	
	ATV66D33N4, D46N4	VY1A66115	
	ATV66D54N4 to D79N4	VY1A66116	
	ATV66C10N4 to C19N4	VY1A66109	
	ATV66C23N41 to C31N41	VY1A66110	

Table 32: Spare Parts List (Continued)

Description	Drive Controller	Reference No.	Note
Ground Fault Sensor — 208/230 V	ATV66D12M2, D16M2	VY1A66114	
	ATV66D23M2, D33M2	VY1A66115	
	ATV66D46M2	VY1A66116	
Control Power Transformer — 460 V	ATV66D33N4 to D79N4	VY1ADA604	
	ATV66C10N4 to C19N4	VY1ADA606	
	ATV66C23N41 to C31N41	VY1ADA607	
Control Power Transformer — 230 V	ATV66D23M2 to D46M2	VY1ADA614	
Control Power Fuses	ATV66C10N4 to C31N41	DF3CF00501	Two fuses
DC Bus Fuse	ATV66C10N4, C13N4	VY1ADF250V700	One fuse per kit
	ATV66C15N4, C19N4	VY1ADF350V700	
	ATV66C23N41 to C31N41	VY1ADF400V700	
AC Line Fuse	ATV66C23N41	VY1ALF700V700	One fuse per kit
	ATV66C28N41	VY1ALF800V700	
	ATV66C31N41	VY1ALF900V700	
Power Terminal Blocks — 460 V	ATV66D16N4, D23N4	VZ3N603	
	ATV66D33N4, D46N4	VZ3N604	
	ATV66D54N4 to D79N4	VZ3N605	
Power Terminal Blocks — 208/230 V	ATV66D12M2, D16M2	VZ3N603	
	ATV66D23M2, D33M2	VZ3N604	
	ATV66D46M2	VZ3N605	
Box Lug Power Terminal	ATV66C10N4 to C19N4	VZ3N008	C10 - C19 (L1-3, T1-3, +, -, GND) C15 - 19 (T1-3, +, -, GND)
Clam Shell Power Terminal	ATV66C10N4 to C19N4	VZ3N009	C15 - 19 (L1-3)
Power Terminal Plexiglass Shield	ATV66C10N4 to C19N4	VY1ADV612	
Internal Power Cables — 460 V	ATV66D16N4, D23N4	VZ3N623	
	ATV66D33N4, D46N4	VZ3N624	
	ATV66D54N4 to D79N4	VZ3N625	
Internal Power Cables — 208/230 V	ATV66D12M2, D16M2	VZ3N627	
	ATV66D23M2, D33M2	VZ3N628	
	ATV66D46M2	VZ3N625	
Dynamic Braking Flexible Bus	ATV66C23N41 to C31N41	VZ3N626	Connects capacitor bank to PA terminal and DB IGBT module
Flex Cables — 460 V (Control Board J3, 4, and 5)	ATV66U41N4 to D12N4	VZ3N601	
	ATV66D16N4, D23N4	VZ3N613	
	ATV66D33N4 to D79N4	VZ3N615	
	ATV66C10N4 to C31N41	VZ3N616	
Flex Cables — 208/230 V (Control Board J3, 4, and 5)	ATV66U41M2 to U90M2	VZ3N601	
	ATV66D12M2, D16M2	VZ3N613	
	ATV66D23M2 to D46M2	VZ3N615	

Table 32: Spare Parts List (Continued)

Description	Drive Controller	Reference No.	Note
Internal Hardware Kit — 460 V	ATV66U41N4 to U72N4	VY1ADV601	
	ATV66U90N4, D12N4	VY1ADV602	
	ATV66D16N4, D23N4	VY1ADV603	
	ATV66D33N4, D46N4	VY1ADV604	
	ATV66D54N4 to D79N4	VY1ADV605	
	ATV66C10N4 to C19N4	VY1ADV613	
	ATV66C23N41 to C31N41	VY1ADV614	
Internal Hardware Kit — 230 V	ATV66U41M2	VY1ADV601	
	ATV66U72M2, U90M2	VY1ADV602	
	ATV66D12M2, D16M2	VY1ADV603	
	ATV66D23M2, D33M2	VY1ADV604	
	ATV66D46M2	VY1ADV605	
Packaging Kits — 208/230/460 V (Order this kit if control basket is NOT mounted to a white metallic ground plane within the drive)	ATV66U41N4 to U72N4	VY1A66101	All plastic sides, covers and front door
	ATV66U90N4, D12N4	VY1A66102	
	ATV66D16N4, D23N4	VY1A66103	
	ATV66U41M2	VY1A66101	
	ATV66U72M2, U90M2	VY1A66102	
	ATV66D12M2, D16M2	VY1A66103	
Packaging Kits — 208/230/460 V (Order this kit if control basket is mounted to a white metallic ground plane within the drive)	ATV66U41N4 to U72N4	VY1A66111	All plastic sides, covers and front door
	ATV66U90N4, D12N4	VY1A66112	
	ATV66D16N4, D23N4	VY1A66113	
	ATV66U41M2	VY1A66111	
	ATV66U72M2, U90M2	VY1A66112	
	ATV66D12M2, D16M2	VY1A66113	
Clip Pliers (Tool for removing voltage regulator heatsink clips)	ATV66U41N4 to D23N4	VY1ADV608	Use when replacing power board, all IGBTs, filter board, precharge components, bus capacitors, diode bridge, temperature sensor, and ground fault sensor
	ATV66U41M2 to D16M2	VY1ADV608	

A

acceleration 12, 68
AC-LIN. OVERVOL 89
additional controllers 40
additional motor 75
AI1/AI2 terminals 46–47, 54
analog inputs 47
analog outputs 47, 55
AO1/AO2 terminals 47, 55
attenuation 30
AUTO-TEST FAIL 90

B

braking
 DC injection 68, 70
 dynamic 44, 73, 91
braking resistance values
 460 V drives 10
 208/230 V drives 12
branch circuit 30–38, 57–58
bus capacitor voltage 78
bypass 75

C

cable 38–39
cable trays 38
capacitance 39
capacitors
 charge relay fault 90
 DC bus 78
 power factor correction 39
caution LED 24, 41–43, 88
circuit diagrams
 control 57–58

 logic inputs 52
 logic outputs 53
CL1/CL2 terminals 44–45
CL21/CL22 terminals 44–45
COM terminal 47–53
compression lug kit 45
condensation 23, 26
conduit
 entries 15–18
 entry plate 30, 38
 wiring requirements 30
constant torque 6, 11, 32, 37,
68, 73–74
contactors
 isolation 58
 line 59–63
 output 75
continuous duty 72
control
 board 46
 circuit diagrams 57–58
 terminals 47
 three-wire 57
 two-wire 57
 types 68–69, 72–73, 76
 voltage supply 44
 wiring precautions 38
controllers
 handling 19
 inspection 20
 installation 20, 26
 part numbers 6–12
 specifications 6–13
 weight 15–18
 wiring 30–40, 64
current
 nominal 67
 overcurrent 30, 89
 ratings 6–12

CUSTOM. FAULT 92

D

DB Resistor 91
DC bus LED 41–43, 78, 84,
88
DC bus voltage 44, 78
DC injection braking 68, 70
DC-BUS OVERVOL 89
deceleration 13, 68
derating 72
dimensions
 clearances 21
 controller 15–18
 recess mounting 26
disconnect switch 22
driving torque 73
dynamic braking 44, 73, 91

E

enclosures
 NEMA Type 1 (IP30) 23–24
 NEMA Type 12 (IP54) 24–
26
 sizing 24
environment 14, 22
equipment requirements 59–63

F

factor 13
fan 23
 also see ventilation 23, 26
 flow rates 23
fault LED 41–43, 88

faults
 control board 90
 DB Resistor 91
 dynamic braking 91
 fault relay 47
 ground 90
 input phase loss 89
 internal connection 90
 LEDs 24, 41, 88
 memory failure 90
 messages 88, 92
 overcurrent 30, 89
 overheating 67, 70, 89
 overload 89
 overspeed 90
 overtemperature 89
 overvoltage 89
 precharge fail 90
 relay 47
 serial link 91
 short circuit 90
 signal 90
 tachogenerator 92
 undervoltage 89
 user-defined 92
FEEDBACK LOSS 92
flux vector 69
frequency
 output 67
 range 13
 specifications 13
 switching 6-12
fuses
 control 59-63
 line power 59-64
 power 57-58
 transformer 59-62

G

GND terminals 44-45
GROUND FAULT 90
grounding 40-43

H

handling 19
heat sink 26
High Torque control 66, 69,
72-73
hoisting 19

I

inductors 39
IN-PHASE LOSS 89
inputs
 disconnect switch 22
 fuses 64
 logic 47, 52
 phase fault 89
 speed reference 13, 47, 54
 supply 47
 terminal strips 41
inspection 20
installation 20, 26
interference 30
INTERNAL FAULT 90
isolation contactor 58

J

J1 terminals 47, 55
J12 terminals 46-47, 52
J13 terminals 46-47, 54-55

J2 terminal 46
jog 68

L

L1/L2/L3 terminals 44-45
LEDs 24, 41-43, 78, 82, 88
 fault LED 24
LI1/LI2/LI3/LI4 terminals 47, 52
lightning arrestors 39
line contactor 59-62
logic inputs 47, 52
logic outputs 53
LOP/LO1/LO2 terminals 47,
53
LOSS FOLLOWER 90

M

maintenance 83
MEMORY FAILURE 90
MOT. OVERLOAD 89
motors
 continuous duty 72
 multiple 71, 75
 noise 69
 overload fault 89
 overload protection 76
 overspeed 73
 overtorque 72
 parallel 75
 permanent magnet 71, 76
 self-ventilating 72
 speed range 72
 synchronous 69, 76
 timing sequence 75
 torque 68, 72
 wound-field 71

mounting
 dimensions 15-18
 NEMA Type 1(IP30) 23-24
 NEMA Type 12 (IP54) 24-26
 recess 26
multiple controllers 40

N

nameplate 3-5
NOLD control 69, 72, 72
Nominal Current 67
nominal output frequency 67
nominal output voltage 67
Normal control 66, 68-69, 72-73

O

options
 compression lug kit 45
 conduit entry plate 30
 recess mounting kit 26
outputs
 analog 47, 55
 contactor 75
 customer supply 47
 dynamic braking 44
 logic 47, 53
 motor 44, 91
 power 44
 relay 47, 55
 terminal strips 41
 wiring 39
overcurrent 30, 89
overheating 67, 70
overload

 fault 89
 protection 76
 relay 70-71
overspeed 73, 90
OVERTEMP DRIVE 89
overtemperature 89
overtorque 72
overvoltage 89

P

PA/PB terminals 44-45, 79-80
parallel motors 75
parts list 27, 59-63, 94
permanent magnet motor 69, 71, 76
phase fault 89
power 13
 control 88
 fuses 57-58
 input line 81
 LED 41-43, 88
 ratings 6-12
 supplies
 control 44
 input line 44
 logic inputs 52
 logic outputs 53
PRECHARGE FAIL 90
preventive maintenance 83
programmable relay 47

R

R1A/R1B/R1C terminals 47
R2A/R2B/R2C terminals 47
ramp time 68

ratings 4
 230 V 11-12
 460 V 6-10
recess mounting 26
reference inputs 47
regenerative torque 73
relays
 capacitor charge 90
 fault 47, 55
 outputs 55
 overload 70-71
 precautions 38
 programmable 47
 terminals 47

S

S terminal 47
safety label 3
sensorless flux vector 69
sensors
 thermal 24
SERIAL LINK 90
serial link fault 90
service factor 72
shielding 38
shock resistance 14
SHORT CIRCUIT 90
short circuit protection 39
slip compensation 67
solenoids 38
spare parts 94
Special control 69, 72, 74, 76
specifications 6-18
speed range 54, 72
speed reference inputs 13, 47, 54

supply
 control 89
 input (external) 52
 input line 81
synchronous motor 76
synchronous reluctance motor 69

T

T1/T2/T3 terminals 44–45
tachogenerator 92
terminals
 +/- 44–45, 79-80
 +10 47, 54
 +24 52–53
 analog outputs 55
 control 47
 logic inputs 52
 logic outputs 53
 power 44–45
 terminal strips 41, 47
thermal limit 24
thermal overload 70, 89
thermal protection 24, 68
three-wire control 57
timing sequence 75
torque
 constant 6, 11, 68, 73–72
 driving 73
 motor 68, 72
 overtorque 72
 regenerative 73
 tightening 45, 64
 variable 8, 9, 11, 12, 68–69, 73–74
transformer fuses 59
transient suppressors 38, 59–62

troubleshooting 88, 92
two-wire control 57

U

U/V/W terminals 44–45
undervoltage 89

V

variable torque 8, 9, 11, 12, 68–69, 73–74
ventilation 23, 26, 72
vibration resistance 14
voltage
 +10 V supply 47, 54
 +24 V supply 47–53
 bus capacitor 78
 control 44
 DC bus 44
 input line 13, 44
 logic inputs 52
 output 67
Volts/Frequency 67

W

weight 15-18
wiring 30-40, 64
 control 38, 57
 general practices 28
 output 39
 power terminals 45
 precautions 38
 wire size 45
wound-field motor 69, 71, 76

Symbols

+/- terminals 44–45, 79-80
+10 terminal 47, 54
+24 terminal 47–53

Numerics

2-wire control 57
3-wire control 57

ATV66 VD0C06S304



10785901920417

86

92041



GROUPE SCHNEIDER

■ Merlin Gerin ■ Square D ■ Telemecanique

VD0C06S304E January 1999 Printed in USA FP
Replaces Bulletin No. VD0C06S304D dated 02/98
© 1994, 1998, 1999 Schneider S.A. All Rights Reserved

Addendum

ALTIVAR® 66 Addendum to VD0C06S304E ATV66 Repair Parts

Retain for future use.

INTRODUCTION

This Addendum replaces Appendix A of instruction bulletin VD0C06S304E, *ALTIVAR 66® Adjustable Speed Drive Controllers for Asynchronous Motors User's Manual, Constant and Variable Torque: 1 to 400 hp, 460 V and 1 to 50 hp, 230 V, Receiving, Installation, and Start-up*. This addendum contains revised repair parts information.

Replacement of repair parts requires the use of special tools and installation procedures not included with the repair parts kits. Before replacing any repair part, consult the *ALTIVAR 66 Drive Controller Service and Troubleshooting Manual*, bulletin number VD0C06S701 (1–75 hp, 100 hp VT) or VD0C06S702 (100–350 hp, 125–400 hp VT). These manuals can be ordered from your local Square D distributor. Repair parts must be replaced only by qualified electrical personnel familiar with the service and troubleshooting manual.

SELECTING REPAIR PARTS FOR ATV66C10N4 TO ATV66C19N4 DRIVE CONTROLLERS

When ordering repair parts for the ATV66C10N4 to ATV66C19N4 drive controllers, check the drive controller serial number and follow these guidelines. Refer to pages 3–5 of bulletin VD0C06S304E for assistance in finding the drive controller serial number.

- If the serial number has a “1” as the seventh digit, select repair parts from the repair parts list beginning on page 2 of this addendum. All drive controllers shipped on or after June 1, 1998 have a “1” as the seventh digit of the serial number. See Figure 2 on page 2 for illustrations of these controllers.
- If the serial number does **not** have a “1” as the seventh digit, consult bulletin VD0C06S702 for repair parts. These are drive controllers that shipped on or before May 31, 1998. They are illustrated in Figure 1.

Use the repair parts list beginning on page 2 of this addendum for all other drive controller models (ATV66U41N4 to ATV66D79N4, ATV66U41M2 to ATV66D46M2, and ATV66C23N4 to ATV66C31N4).

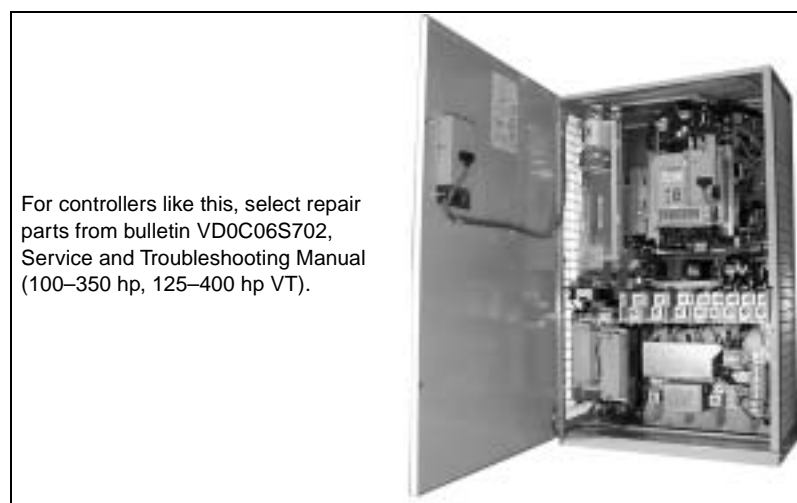

For controllers like this, select repair parts from bulletin VD0C06S702, *Service and Troubleshooting Manual* (100–350 hp, 125–400 hp VT).

Figure 1: ATV66C10N4–C19N4: Shipped On or Before May 31, 1998

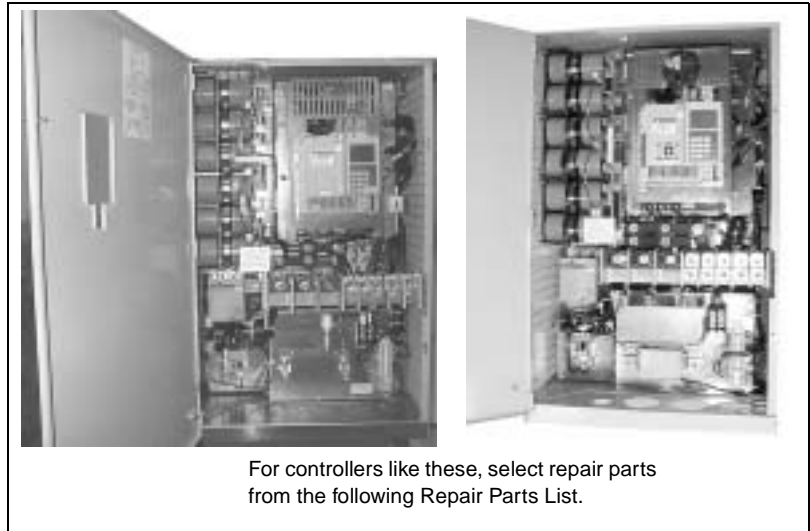

Figure 2: ATV66C10N4–C19N4: Shipped On or After June 1, 1998

Repair Parts List

Description	Drive Controller	Part No.	Note
ALTIVAR 66 Adjustable Speed Drive Controllers Service and Troubleshooting Manual	ATV66 1–75 hp, 100 hp VT	VD0C06S701	
	ATV66 100 hp CT, 125–400 hp	VD0C06S702	
Control Kit — 460 V	ATV66U41N4 to D79N4 ATV66C10N4 to C31N4	VX4A66CK1 VX4A66CK2	
Control Kit — 208/230 V	ATV66U41M2 to D46M2 (except ATV66D23M2S264U)	VX4A66CK1	Matched keypad display and control basket with latest firmware
	ATV66D23M2S264U	VX4A66CK1S260	
Keypad Display Refer to the section “Identifying the Firmware Version” in Chapter 4 of bulletin VD0C06S304E and determine the firmware version of your drive controller.			
For drive controllers with firmware level 3.0 and later	ATV66 all sizes	VW3A66206U	
For drive controllers with firmware version earlier than 3.0	Order the control kit listed above that is appropriate for your drive controller.		
Removable Control Terminal Strips	ATV66 all sizes	VZ3N006	J1, J12, and J13 on control basket

Repair Parts List (Continued)

Description	Drive Controller	Part No.	Note
Power Board — 460 V	ATV66U41N4	VX5A66U41N4	Includes IGBT block, rectifier diode, heatsink, and fan
	ATV66U54N4	VX5A66U54N4	
	ATV66U72N4	VX5A66U72N4	
	ATV66U90N4	VX5A66U90N4	
	ATV66D12N4	VX5A66D12N4	
	ATV66D16N4	VX5A66D16N4	
	ATV66D23N4	VX5A66D23N4	Power board only
	ATV66D33N4	VX5A66D33N4	
	ATV66D46N4	VX5A66D46N4	
	ATV66D54N4	VX5A66D54N4	
	ATV66D64N4	VX5A66D64N4	
	ATV66D79N4	VX5A66D79N4	
	ATV66C10N4	VX5A661C10N4	
	ATV66C13N4	VX5A661C13N4	
	ATV66C15N4	VX5A661C15N4	
	ATV66C19N4	VX5A661C19N4	
	ATV66C23N4	VX5A661C23N4	
	ATV66C28N4	VX5A661C28N4	
ATV66C31N4	VX5A661C31N4		
Power Board — 208/230 V	ATV66U41M2	VX5A662U41M2	Includes IGBT block and rectifier diode
	ATV66U72M2	VX5A662U72M2	
	ATV66U90M2	VX5A662U90M2	
	ATV66D12M2	VX5A66D12M2	Power board only
	ATV66D16M2	VX5A66D16M2	
Power Board and Gate Driver Board — 208/230 V	ATV66D23M2	VX5A66D234M2	Matched set
	ATV66D33M2	VX5A66D335M2	
	ATV66D46M2	VX5A66D466M2	
Gate Driver Board — 460 V	ATV66D16N4	VX5A66103	Gate driver board only
	ATV66D23N4	VX5A66104	
	ATV66D33N4	VX5A66105	
	ATV66D46N4	VX5A66106	
	ATV66D54N4	VX5A66107	
	ATV66D64N4	VX5A66108	
	ATV66D79N4	VX5A66109	
Gate Driver Board — 208/230 V	ATV66D12M2	VX5A66112	
	ATV66D16M2	VX5A66113	
Inverter IGBT — 460 V [1] For units with a serial number starting with "6W", or for units with a serial number starting with "86" and a date code of 0216 or earlier. [2] For units with a serial number starting with "86" and a date code of 0217 or later. Refer to pages 3–5 of bulletin VD0C06S304E for assistance in finding the serial number and date code.	ATV66D16N4	VZ3IM2050M1201	1 dual IGBT block
	ATV66D23N4	VZ3IM2075M1201	
	ATV66D33N4	VZ3IM2100M1201	
	ATV66D46N4, D54N4	VZ3IM2150M1201	
	ATV66D64N4	VZ3IM2200M1201	
	ATV66D79N4 [1]	VZ3IM2300M1201	
	ATV66D79N4 [2]	VZ3IM2200M1202	
	ATV66C10N4	VZ3IM2300M1202	
	ATV66C13N4 to C19N4	VZ3IM2400M1202	
	ATV66C23N4, C28N4	VZ3IM1400M1207	
ATV66C31N4	VZ3IM1500M1207	2 IGBT blocks, 2 snubber boards, 2 gate driver boards, 1 clamp module	
			4 IGBT blocks, 2 snubber boards, 2 gate driver boards

Repair Parts List (Continued)

Description	Drive Controller	Part No.	Note
Inverter IGBT — 208/230 V	ATV66D12M2	VZ3IM2075M0601	1 dual IGBT block
	ATV66D16M2	VZ3IM2100M0601	
	ATV66D23M2	VZ3IM2150M0601	
	ATV66D33M2	VZ3IM2200M0601	
	ATV66D46M2	VZ3IM2300M0601	
Inverter IGBT Clamp Capacitor	ATV66C23N4 to C31N4	VY1ADC610	1 capacitor
Dynamic Braking IGBT — 460 V	ATV66D16N4, D23N4	VZ3IM1025M1001	1 IGBT Block
	ATV66D33N4, D46N4	VZ3IM2050M1201	
	ATV66D54N4	VZ3IM2100M1201	
	ATV66D64N4, D79N4	VZ3IM2150M1201	1 IGBT block, 1 diode block, 1 snubber board, 1 gate driver board
	ATV66C10N4 to C19N4	VZ3IM1300M1202	
	ATV66C23N4	VZ3IM1400M1208	
Dynamic Braking IGBT — 208/230 V	ATV66C28N4, C31N4	VZ3IM1300M1208	2 IGBT blocks, 2 diode blocks, 2 snubber boards, 1 gate driver board
	ATV66D12M2, D16M2	VZ3IM1060M0601	1 IGBT block
	ATV66D23M2	VZ3IM2075M0601	
	ATV66D33M2	VZ3IM2100M0601	
	ATV66D46M2	VZ3IM2150M0601	
Dynamic Braking Clamp Capacitor	ATV66C10N4 to C19N4	VY1ADC616	1 capacitor
	ATV66C23N4 to C31N4	VY1ADC614	
Line Filter Board — 460 V	ATV66D16N4, D23N4	VX4A66103	Board only
	ATV66D33N4, D46N4	VX4A66104	
	ATV66D54N4 to D79N4	VX4A66105	Assembly with board and capacitors
	ATV66C10N4 to C31N4	VX4A66106	
Line Filter Board — 208/230 V	ATV66D12M2, D16M2	VX4A66103	Board only
	ATV66D23M2, D33M2	VX4A66104	
	ATV66D46M2	VX4A66105	
Line Rectifier Diode — 460 V	ATV66D16N4, D23N4	VZ3DM6075M1601	6-pack diode block
	ATV66D33N4	VZ3DM2080M1606	1 dual diode block
	ATV66D46N4	VZ3DM2100M1601	
	ATV66D54N4 to D79N4	VZ3DM2160M1606	
	ATV66C10N4, C13N4	VZ3DM2170M1602	
	ATV66C15N4	VZ3DM2260M1602	
	ATV66C19N4	VZ3DM2350M1602	
	ATV66C23N4 to C31N4	VZ3DM2600M1602	
Line Rectifier Diode — 208/230 V	ATV66D12M2, D16M2	VZ3DM6075M1601	6-pack diode block
	ATV66D23M2	VZ3DM2080M1606	1 dual diode block
	ATV66D33M2	VZ3DM2100M1601	
	ATV66D46M2	VZ3DM2160M1606	
DC Bus Capacitor—460 V	ATV66D16N4, D23N4	VY1ADC152V450	1 capacitor
	ATV66D33N4, D46N4	VY1ADC472V450	Assembly with capacitors and stirring fan
	ATV66D54N4	VY1ADC605	
	ATV66D64N4, D79N4	VY1ADC606	Assembly with capacitors
	ATV66C10N4 to C19N4	VY1ADC615	
	ATV66C23N4 to C31N4	VY1ADC608	
DC Bus Capacitor—208/230 V	ATV66D12M2, D16M2	VY1ADC152V450	1 capacitor
	ATV66D23M2, D33M2	VY1ADC472V450	Assembly with capacitors and stirring fan
	ATV66D46M2	VY1ADC605	

Repair Parts List (Continued)

Description	Drive Controller	Part No.	Note
DC Bus Capacitor Bank Plexiglass Shield	ATV66C10N4 to C19N4	VY1ADV611	Shield with mounting screws
Discharge Resistor — 460 V	ATV66D33N4 to D79N4	VZ3R5K0W040	1 resistor
	ATV66C10N4 to C19N4	VZ3R2K5W600	2 resistors
	ATV66C23N4 to C31N4	VZ3R1K2W480	
Discharge Resistor — 208/230 V	ATV66D23M2 to D46M2	VZ3R5K0W040	
Precharge Resistor — 460 V	ATV66D16N4, D23N4	VZ3R033W009	1 resistor
	ATV66D33N4, D46N4	VZ3R010W025	
	ATV66D54N4 to D79N4	VZ3R010W481	
	ATV66C10N4 to C31N4	VZ3R010W270	2 resistors
Precharge Resistor — 208/230 V	ATV66D12M2, D16M2	VZ3R033J710	
	ATV66D23M2, D33M2	VZ3R010W025	1 resistor
	ATV66D46M2	VZ3R010W481	
Precharge Contactor — 460 V	ATV66D16N4, D23N4	LP4D1801BW3	1 contactor
	ATV66D33N4	LC1D1801P7	
	ATV66D46N4	LC1D2501P7	
	ATV66D54N4, D64N4	LC1D4011P7	
	ATV66D79N4	LC1D6511P7	
	ATV66C10N4, C13N4	VY1A661C1010	
	ATV66C15N4, C19N4	VY1A661C1510	
Precharge Contactor — 208/230 V	ATV66D12M2, D16M2	LP4D2500BW3	
	ATV66D23M2	LC1D3201P7	
	ATV66D33M2	LC1D5011P7	
	ATV66D46M2	LC1D4011P7	
Precharge Contactor Auxiliary Contact Block	ATV66C10N4 to C31N4	LA1DN04	1 contact block
Precharge Circuit Protector	ATV66C10N4 to C31N4	GV2M10	
Heatsink Fan — 460 V	ATV66U41N4, U54N4	VZ3V661	Fan(s) and mounting bracket
	ATV66U72N4	VZ3V662	
	ATV66U90N4, D12N4	VZ3V663	
	ATV66D16N4, D23N4	VZ3V664	
	ATV66D33N4 to D79N4	VZ3V665	1 fan
	ATV66C10N4 to C19N4	VZ3V670	Fan assembly and capacitor
	ATV66C23N4 to C31N4	VZ3V666	1 fan and capacitor
Heatsink Fan — 208/230 V	ATV66U41M2	VZ3V662	Fan(s) and mounting bracket
	ATV66U72M2, U90M2	VZ3V663	
	ATV66D12M2, D16M2	VZ3V664	
	ATV66D23M2 to D46M2	VZ3V665	1 fan
Stirring Fan — 460 V	ATV66D33N4 to D79N4	VZ3V6654	Power board fan
	ATV66D54N4 to D79N4	VZ3V6655	Capacitor bank fan
	ATV66C10N4 to C19N4	VZ3V671	Power board fan
	ATV66C23N4 to C31N4	VZ3V669	IGBT fan
Stirring Fan — 208/230 V	ATV66D23M2 to D46M2	VZ3V6654	Power board fan
	ATV66D46M2	VZ3V6655	Capacitor bank fan
Fan Failure Detection Assembly	ATV66C23N4 to C31N4	VY1ADR100	Resistor and temperature switch
Fan Failure Relay Assembly	ATV66C23N4 to C31N4	VZ3SA66012	Relay and retaining clip
Power Supply for Overtemperature Detection Circuit	ATV66C23N4 to C31N4	VY1A66200	Power supply only
Heatsink Temperature Sensor	ATV66C10N4 to C31N4	VZ3GN005	NTC thermistor and cable

Repair Parts List (Continued)

Description	Drive Controller	Part No.	Note
Temperature Switch	ATV66C10N4 to C19N4	VZ3G007	1 switch—mounted on fuse bar
	ATV66C10N4 to C19N4	VZ3G008	2 switches—mounted on heatsink and motor current sensor
	ATV66C23N4 to C31N4	VZ3G004	1 68 °C switch and 1 85 °C switch, heatsink mounted
Motor Current Sensor — 460 V	ATV66D33N4, D46N4	VY1A66104	2 sensors
	ATV66D54N4 to D79N4	VY1A66105	
	ATV66C10N4, C13N4	VY1A66106	1 sensor
	ATV66C15N4, C19N4	VY1A66107	
	ATV66C23N4 to C31N4	VY1A66108	
Motor Current Sensor — 208/230 V	ATV66D23M2	VY1A66104	2 sensors
	ATV66D33M2, D46M2	VY1A66105	
Ground Fault Sensor—460 V	ATV66C10N4 to C19N4	VY1A66109	1 sensor
	ATV66C23N4 to C31N4	VY1A66110	
Control Power Transformer — 460 V	ATV66D33N4 to D79N4	VY1ADA604	Transformer only
	ATV66C10N4 to C19N4	VY1ADA606	
	ATV66C23N4 to C31N4	VY1ADA607	
Control Power Transformer — 230 V	ATV66D23M2 to D46M2	VY1ADA614	
Control Power Fuses	ATV66C10N4 to C31N4	DF3CF00501	2 fuses, F5 and F6
DC Bus Fuse	ATV66C10N4, C13N4	VY1ADF250V700	1 fuse
	ATV66C15N4, C19N4	VY1ADF350V700	
	ATV66C23N4 to C31N4	VY1ADF400V700	
AC Line Fuse	ATV66C23N4	VY1ALF700V700	1 fuse
	ATV66C28N4	VY1ALF800V700	
	ATV66C31N4	VY1ALF900V700	
Power Terminal Blocks — 460 V	ATV66D16N4, D23N4	VZ3N603	All output terminals and DIN rail for mounting
	ATV66D33N4, D46N4	VZ3N604	
	ATV66D54N4 to D79N4	VZ3N605	
Power Terminal Blocks — 208/230 V	ATV66D12M2, D16M2	VZ3N603	All output terminals and DIN rail for mounting
	ATV66D23M2, D33M2	VZ3N604	
	ATV66D46M2	VZ3N605	
Box Lug Power Terminal	ATV66C10N4 to C19N4	VZ3N008	Three terminals for replacing power or ground terminals ATV66C10N4–C13N4: L1, L2, L3, T1, T2, T3, +, –, GND ATV66C15N4–C19N4: T1, T2, T3, +, –, GND
Clam Shell Power Terminal	ATV66C15N4 to C19N4	VZ3N009	Three terminals for replacing power terminals L1, L2, L3
Power Terminal Plexiglass Shield	ATV66C10N4 to C19N4	VY1ADV612	
Dynamic Braking Flexible Bus	ATV66C23N4 to C31N4	VZ3N626	Connects capacitor bank to PA terminal and DB IGBT module
Flex Cables — 460 V (Control Board J3, J4, and J5)	ATV66U41N4 to D12N4	VZ3N601	3 flat ribbon cables
	ATV66D16N4, D23N4	VZ3N613	
	ATV66D33N4 to D79N4	VZ3N615	
	ATV66C10N4 to C31N4	VZ3N616	
Flex Cables — 208/230 V (Control Board J3, J4, and J5)	ATV66U41M2 to U90M2	VZ3N601	3 flat ribbon cables
	ATV66D12M2, D16M2	VZ3N613	
	ATV66D23M2 to D46M2	VZ3N615	

Repair Parts List (Continued)

Description	Drive Controller	Part No.	Note
Internal Hardware Kit — 460 V	ATV66U41N4 to U72N4	VY1ADV601	Specialty hardware, mounting posts, etc.
	ATV66U90N4, D12N4	VY1ADV602	
	ATV66D16N4, D23N4	VY1ADV603	
	ATV66D33N4, D46N4	VY1ADV604	
	ATV66D54N4 to D79N4	VY1ADV605	
	ATV66C10N4 to C19N4	VY1ADV613	
	ATV66C23N4 to C31N4	VY1ADV614	
Internal Hardware Kit — 230 V	ATV66U41M2	VY1ADV601	
	ATV66U72M2, U90M2	VY1ADV602	
	ATV66D12M2, D16M2	VY1ADV603	
	ATV66D23M2, D33M2	VY1ADV604	
	ATV66D46M2	VY1ADV605	
Packaging Kits — 208/230/460 V (Order this kit if the control basket is not mounted to a white metallic ground plane within the drive controller)	ATV66U41N4 to U72N4	VY1A66101	All plastic sides, covers, and front door
	ATV66U90N4, D12N4	VY1A66102	
	ATV66D16N4, D23N4	VY1A66103	
	ATV66U41M2	VY1A66101	
	ATV66U72M2, U90M2	VY1A66102	
ATV66D12M2, D16M2	VY1A66103		
Packaging Kits — 208/230/460 V (Order this kit if the control basket is mounted to a white metallic ground plane within the drive controller)	ATV66U41N4 to U72N4	VY1A66111	
	ATV66U90N4, D12N4	VY1A66112	
	ATV66D16N4, D23N4	VY1A66113	
	ATV66U41M2	VY1A66111	
	ATV66U72M2, U90M2	VY1A66112	
Clip Pliers (Tool for removing voltage regulator heatsink clips)	ATV66U41N4 to D23N4	VY1ADV608	Use when replacing power board, all IGBTs, filter board, precharge components, bus capacitors, and line rectifier diodes.
	ATV66U41M2 to D16M2		

Square D Company
8001 Hwy 64 East
Knightdale, NC 27545
1-888-SquareD (1-888-778-2733)
www.SquareD.com

Electrical equipment should be serviced only by qualified personnel. No responsibility is assumed by Schneider Electric for any consequences arising out of the use of this material. This document is not intended as an instruction manual for untrained persons.