

STACK
ANNEX

5

061

471

FIRST YEAR LATHE WORK

BEST BOOK for STUDENTS in TECHNICAL and MANUAL TRAINING SCHOOLS

PRICE 10 CENTS



SOUTH BEND LATHE WORKS

SOUTH BEND, INDIANA, U. S. A.

B

0000032359

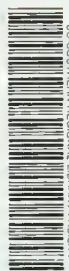

UC SOUTHERN REGIONAL LIBRARY FACILITY

California
Regional
Library

The demand for machinists is so great and the supply so limited in nearly every city in the United States that the manufacturers in the larger cities have a standing offer with the Manual Training Schools for the employment of all young men who have finished the machine shop course.

FIRST YEAR LATHE WORK

*Prepared for Students in Technical, Manual Training,
and Trade Schools, and for the Apprentice in the Shop*

¶ The student in the school shop takes a deep interest in making parts for a machine, knowing that the machine will be assembled, and placed in operation in the school shop. This will give him an opportunity to observe the reasons for the various operations on each job.

¶ The instructor will be relieved of endless and unnecessary detail, if the instruction plan in this book is followed.

¶ The instruction plan for building this little Grinder has been arranged to follow closely the methods used in modern shop practice, so that the student who finishes "First Year Lathe Work" intelligently, will be familiar with many of the fundamentals, when he starts out in life on his first job in the industrial machine shop.

Copyright 1917 by O'BRIEN BROS.
—J. J. O'Brien, M. W. O'Brien

TEXT BOOK No. 2

SOUTH BEND LATHE WORKS SOUTH BEND, IND., U. S. A.
428 E. MADISON STREET

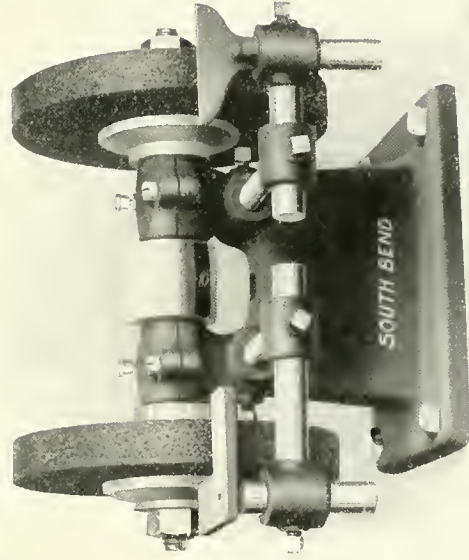

8-inch Bench Tool Room Emery Grinder

Machined Complete on a 15-inch South Bend Lathe

The half-tone above was taken from a photograph of one of the 8-inch Tool Room Emery Grinders, which was built according to instructions in this book. This half-tone shows the bench grinder as it will appear when finished.

Spindle Speed	1700 R. P. M.
Size of Emery Wheels: 8" Diameter, $\frac{3}{4}$ " Face, $\frac{3}{4}$ " Hole.	
Net weight of Grinder as shown, including safety guards.....	50 lbs.
Safety guards are not shown in cut.	

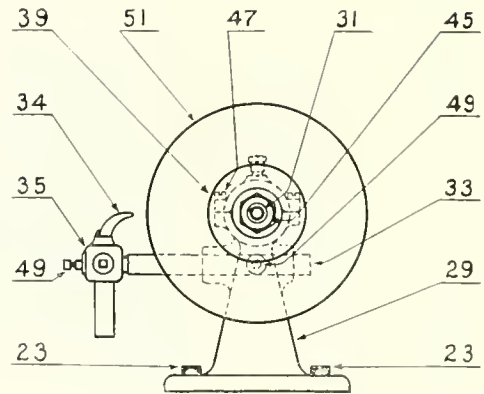
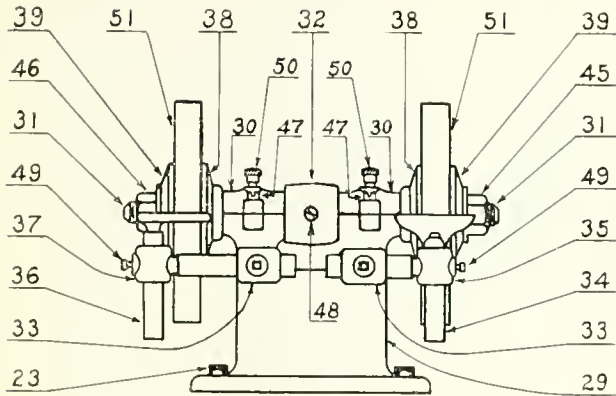

Part Numbers and Names of 8-Inch Bench Grinder

PART NO.	NAME	PART NO.	NAME	PART NO.	NAME
23	Machine Bolts (4)	34	"T" Rest	45	R. H. Spindle Hex. Nut
29	Grinder Head	35	"T" Rest Bracket	46	L. H. Spindle Hex. Nut
30	Caps (2)	36	Angle Rest	47	Fillister Head Cap Screws (4)
31	Spindle	37	Angle Rest Bracket	48	Headless Set Screw
32	Spindle Pulley	38	Inside Flanges (2)	49	Sq. Head Set Screws (6)
33	Rest Brackets L.(2)	39	Outside Flanges (2)	50	Oil Cups (2)
				51	Emery Wheels (2)

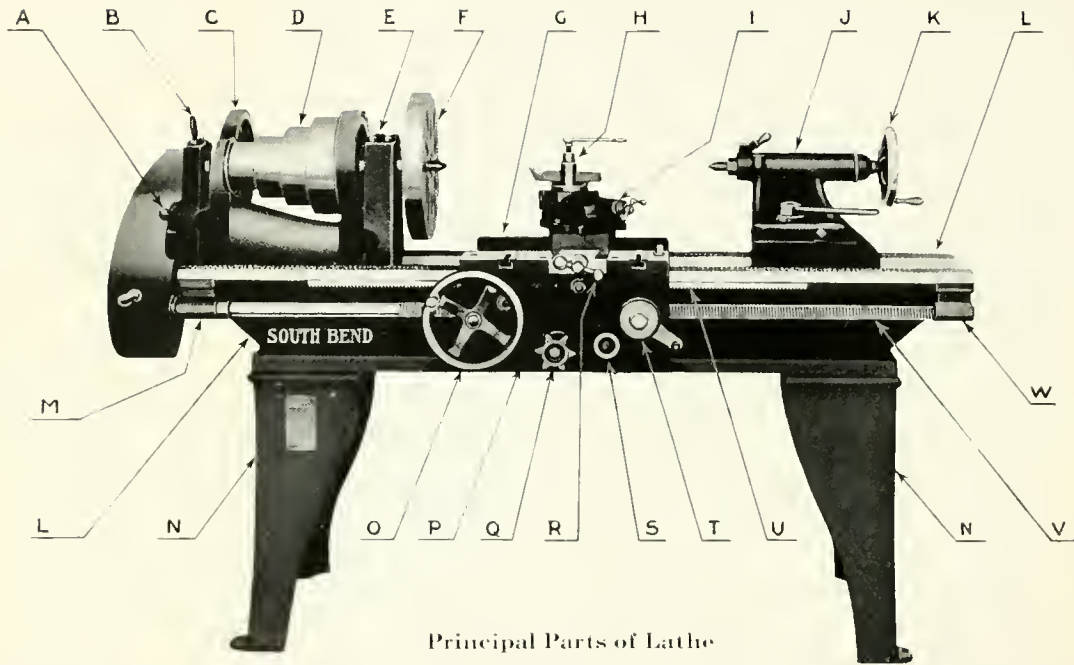

Principal Parts of Lathe

- | | | | |
|---------------------|---------------------------|-----------------------------|---------------------------------------|
| A — Reverse | G — Saddle | M — Lead Screw Bracket Head | R — Cross Feed Ball Crank |
| B — Back Gear Lever | H — Tool Post | N — End | S — Cross Feed Lever Knob |
| C — Back Gears | I — Compound Rest | N — Legs | T — Apron Nut Cam |
| D — Spindle Cone | J — Tail Stock | O — Apron Hand Wheel | U — Rack |
| E — Head Stock | K — Tail Stock Hand Wheel | P — Apron | V — Lead Screw |
| F — Face Plate | L — Lathe Bed | Q — Apron Clutch | W — Lead Screw Bracket Tail-stock End |

Principal Parts of a Standard Engine Lathe

On Page 4 we illustrate a Standard Screw Cutting Engine Lathe. We have lettered a few of the most important parts, so that the beginner may become familiar with their use.

This Engine Lathe is equipped with automatic longitudinal feed and automatic cross feed. To operate the automatic longitudinal feed, loosen Knob "S" by unscrewing, then push it down as far as it will go, and screw tight. Fasten Knob "Q" tight. The automatic longitudinal feed is now in operation.

To release automatic longitudinal feed, simply unscrew Knob "Q," which releases the friction feed.

To connect the automatic cross feed, unscrew Knob "S" and lift it as high as it will go, then screw tight, fasten Knob "Q" tight. Now the automatic cross feed is connected.

When the automatic cross feed is connected, the automatic longitudinal feed is disconnected. When the automatic longitudinal feed is connected the automatic cross feed is disconnected. Therefore it is impossible to have both feeds connected at the same time, and while one feed is in operation it is impossible for the other feed to drop in.

For screw cutting neither of the automatic feeds are used, so when cutting a screw be sure to see that Knob "Q" is loose, not tight. In cutting a screw or thread, the split nuts are clamped on to the lead screw by Cam "T". For the detail of thread cutting see Section 37 of book entitled "How to Run a Lathe."

Oil the lathe frequently. If the lathe is used every day, it should be oiled every morning before starting. Use a good grade of machine oil, none other. Oil the head stock spindle, the back gear quill, the spindle cone, the thrust collar, the lead screw bearings, the apron gears and studs, the carriage bearings, the rear carriage gib; and move or operate each part by hand, to see that it moves freely, before starting the lathe.

For further information of details and parts of the Screw Cutting Engine Lathe, see little book entitled "How to Run a Lathe," described on page 64 of this book.

CATALOG. Free interesting catalog, No. 50, just off the press, describing the entire line of South Bend Lathes, showing prices of all lathes and attachments. **Catalog mailed free to any address.**

Centering

To machine a shaft on centers in the lathe, it is necessary that it be centered. A hole is drilled and countersunk in each end so that the shaft may revolve on lathe centers. Before centering a piece of soft steel, care should be taken that the shaft is as straight as possible, because the straighter the piece is, the smaller the diameter of the rough stock required.

There are many ways of centering. The simplest is to chalk the end of the shaft to be centered. Scratch two lines at right angles to each other, and where these lines intersect will be the approximate center of the shaft. See Fig. 4.

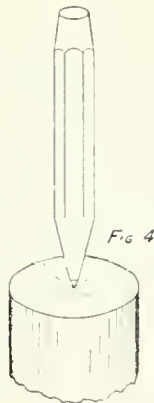

Drive center punch on the intersection of lines on both ends of the shaft. Place the shaft thus punched, on the centers of the lathe, revolve by hand; if it does not run true, hold a piece of chalk to the shaft while revolving and it will mark the high spots. Place shaft in the vise once more, drive the center in the direction necessary to have the shaft run true.

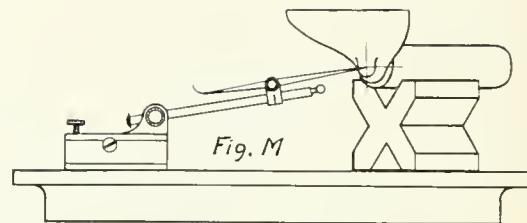

Centering an Irregular Piece

Figure "M" shows the method of centering the T Rest, or any irregular part that has a round shank.

Chalk the ends of the part to be centered, and place the part to be turned on the "V" Block. With a surface gauge make a mark on both ends of the piece. Then revolve the piece on the "V" Block a quarter of a revolution, and make another mark on each end. Complete the four quarters of a revolution in this manner. The intersection of these marks will be the proper center point.

If the piece to be machined is close to size in the rough so that very little stock is left for finishing, care should be taken to see that the bar is straight as possible and that the center holes are located accurately so that the shaft may be true all over when finished.

Drill and countersink each end of the shaft until a depth is reached sufficient to support the shaft on the centers while it is being machined. A good method of countersinking is shown in Fig. 5.

In centering a shaft that is over 3 or 4 pounds in weight, care should be taken to see that the weight of the shaft does not break the center drill. If the piece being centered is steel or iron, there

should be oil used on the center drill, and the operator should feed the shaft slowly to the drill.

If for any reason a center drill breaks and part of the broken drill remains in the shaft, this broken part should be immediately removed. Sometimes you may be able to work the broken part out with a chisel, but occasionally it sticks so hard that it cannot be removed. In that case, the broken part of the drill left in the shaft must be annealed, and the only way to anneal it is to anneal the end of the shaft. For annealing see Section 63, Lathe Book. (How to Run a Lathe.)

Long shafts may be centered with a breast drill or brace and bit. The regular countersinks may be used in the same manner.

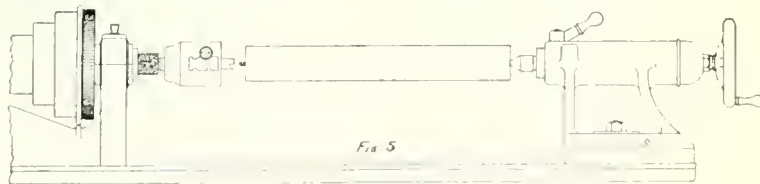

Countersinking a Shaft in the Lathe

A drill chuck, holding a combined drill and countersink (See Fig. 5B, page 8), is fitted to the head spindle of lathe. The shaft has already been center punched. Place end of shaft on tail center and

hold with left hand, and feed to the drill by turning the wheel of tail stock. Allow the countersink to enter the proper depth, countersink the other end in the same manner.

Drill and Countersink Combined

Fig. 5B shows a combined drill and countersink, which is both the center drill and countersink. Centering may also be done by a small twist drill for the center hole and a larger twist drill ground 60 degrees following as a countersink.



Fig. 5B



Fig. 8



Fig. 9

Figs. 8 and 9 show two styles countersink that are used to follow the small twist drill for countersinking.

Fig. 7 shows the style of countersink which gives best results. A small hole is first drilled beyond the depth of the point of the lathe center; it is then countersunk on an angle of 60 degrees to fit the lathe center.

Proper Countersink

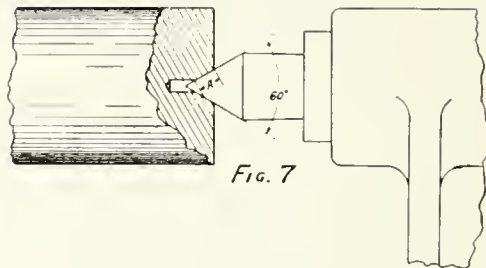

Fig. 7

Improper Centering

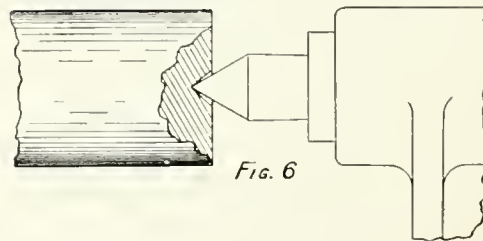
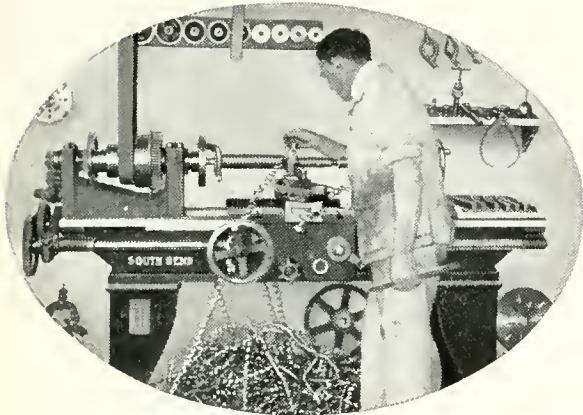

Fig. 6



Turning a Steel Shaft

The illustration above shows a steel shaft being machined on a lathe. The shaft is driven between centers by a common lathe dog that is firmly attached by a set screw, the tail of the dog enters the slot in the face plate.

Lathe Dogs

The common lathe dog is used for driving round or cylindrical pieces that are machined between centers on the lathe.

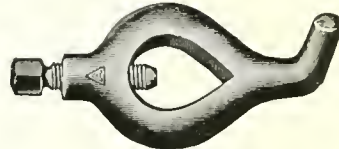

Common Lathe Dog

The clamp lathe dog is used for the same purpose as the common dog, but is more practical for holding rectangular work.

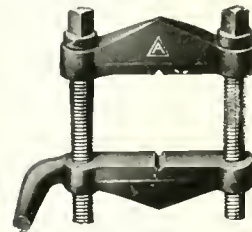

Clamp Lathe Dog

The names of a few schools using South Bend Lathes will be found on the outside cover.

Patent Turning Tool



Illustration herewith shows a Patent Turning Tool. Some mechanics prefer to use the Patent Tools rather than the forged steel lathe tools.

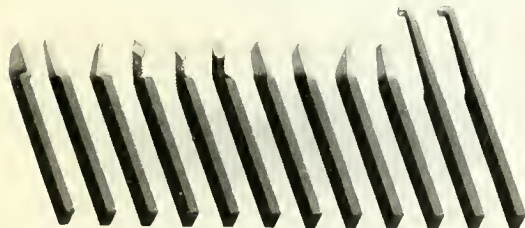

1 2 3 4 5 6 7 8 9 10 11 12

Forged Steel Lathe Tools

- | | |
|----------------------------|--------------------------|
| 1 Left-hand Side Tool | 7 Cutting-off Tool |
| 2 Right-hand Side Tool | 8 Threading Tool |
| 3 Right-hand Bent Tool | 9 Bent Threading Tool |
| 4 Right-hand Diamond Point | 10 Roughing Tool |
| 5 Left-hand Diamond Point | 11 Boring Tool |
| 6 Round Nose Tool | 12 Inside Threading Tool |

Forged Steel Lathe Tools

The twelve lathe tools illustrated have been selected as the most practical set of forged tools for general all-round work on the lathe. These tools are made both in carbon and the high speed steels. The size of the tools vary to suit the different size lathes.

Lathe Tools

The drawings on page 11 show the application of the above twelve lathe tools. It is not necessary to use forged steel lathe tools, as the patent lathe tool shown herewith may be applied in the same way.

The arrow shows the direction of the feed of the tool. In some cases the tool may be fed to advantage in two directions. For example, in drawing No. 1, the arrow shows the tool feeding out toward the periphery. This tool may also be fed in toward the center. Again, in drawing No. 11, the boring tool is feeding to the left. This tool may also take a cut in feeding to the right.

Patent Lathe Tools

There are several lines of excellent patent lathe tools on the market for turning, boring, thread cutting, knurling, etc.

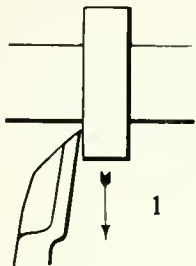

1

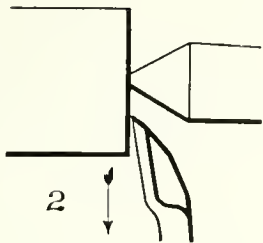

2

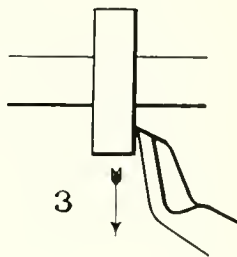

3

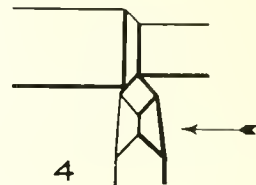

4

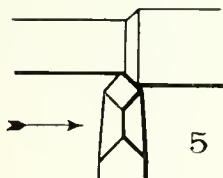

5

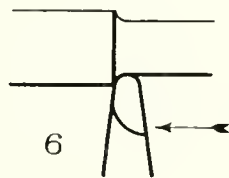

6

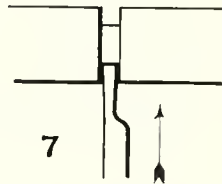

7

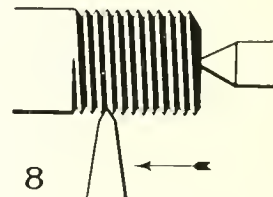

8

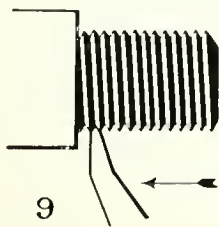

9

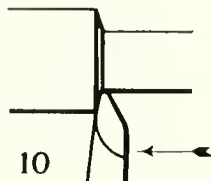

10

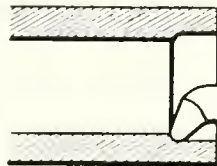

11

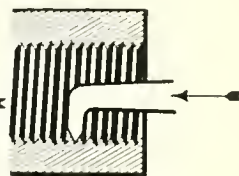

12

SOUTH BEND LATHE WORKS.

The Position of Cutting Edge of Tool

In setting a tool for cutting threads, turning taper, or boring, the height of the cutting edge of the tool should be in a line with the axis or point of the lathe center.

The position of the cutting edge of a turning tool for machining metal is quite important. In most

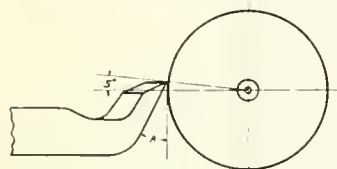

Fig. 12

work, we find that about 5 degrees above the center gives best results. (See Fig. 12.) The position of the tool also depends upon its clearance and

rake, and upon the material to be cut as: cast iron, soft steel, or tool steel, etc. A little practice will enable operator to learn the proper height on different jobs.

Care should be taken that the cutting edge of the tool does not extend too far from the tool post, especially on a heavy cut, because the nearer the tool post is to the work, the more firmly the tool can be held.

The surface scale on a piece of cast iron is often very hard and sometimes will ruin the cutting point of the tool. For this reason the first or roughing cut should be deep enough to get under

the scale. The scale must also be remembered when turning a piece of steel, as some kinds of steel contain a scale that will quickly dull the cutting edge of the turning tool.

Grinding the Tool

The efficiency of the cutting edge of a tool depends a great deal upon the way it is ground or sharpened. The tool should have plenty of clearance, a good rake and a clean cutting edge. The cutting edge of the tool is changed somewhat for various metals. After grinding a tool it would be well to dress up the cutting edge by hand with a small oil stone. This will improve its wearing qualities.

Direction of Feed With a Job on Centers

In machining a job on centers in the lathe, the feed of the tool should always be, when possible, in the direction of the head spindle. The reason is obvious: When the carriage is feeding toward the head spindle and the tool taking a heavy chip, the pressure is on the head center which revolves with the work. Should the tool when taking a heavy chip feed toward the tail stock, then the pressure is on the tail center, which is stationary, and is, therefore, liable to heat unless oiled frequently.

Facing End of Shaft

When a shaft is being machined on centers, if accurate work is to be done, the ends of shaft must be faced so that they will ride on the centers evenly. A side tool is usually used to do the facing. (See Fig. 11.)

In facing with a side tool it may be necessary to face into the countersink hole. On reaching the edge of the countersink, tail center may be withdrawn slightly. This enables the side tool to face the end clean.

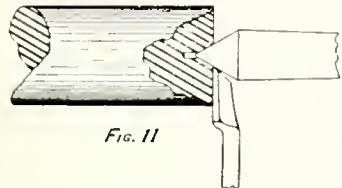

Fig. 11

When shaft is faced ready for general machining, place a drop of oil on the tail stock center, also a drop in the countersunk hole of shaft. Adjust the tail stock center so that the shaft has a slight play on the centers (it must not turn hard on the centers), then fasten the tail stock spindle by the binding clamp. **Keep oil on the tail center.**

When we refer to Lathe Book, we mean book entitled "How to Run a Lathe."

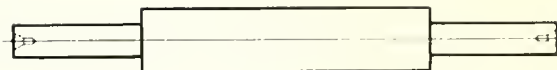

Fig. A.

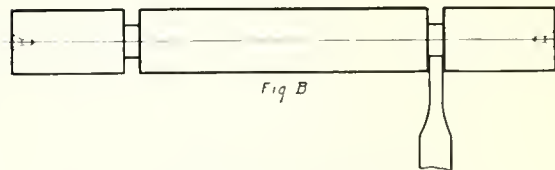

Fig. B

Turning to a Shoulder

The above illustrations Figure "A" and Figure "B," show the advantage of using a Cutting-Off Tool in locating the shoulder on a turned shaft. Start the Cutting-Off Tool about $1/32$ " from the finished line of the shoulder and feed in until you reach a diameter about $1/32$ " larger than the finish size, then rough the stock off with a diamond point tool and finish the face of shoulder with a side tool.

For illustration, description and principal dimensions of South Bend Lathes, see pages 62 and 63 of this book.

Job No. 1. Part No. 35. Drawing No. 135.

1. **CLEANING THE CASTING.** All sand, gates and sprues should be removed from the casting, by chipping, grinding and filing.

2. **CENTERING.** To locate the centers, follow instructions shown on pages 6, 7 and 8.

3. **DRIVING.** Attach a common lathe dog to the solid end of Rest Bracket. Place the bracket on centers, put a couple drops of oil on the tail center point, adjust the tail center so that the bracket has slight play on centers — not too loose; then clamp tail spindle firmly.

4. **CUTTING SPEED.** The material, being cast iron, the proper cutting speed for Job No. 1 is 55-feet per minute. This being the first job, perhaps it would be better not to run over 40-feet per minute. Rule for Cutting Speed of Metals will be found in Section 44 of book entitled "How to Run a Lathe." (See page 64.)

5. **HEIGHT OF TOOL.** For the position of the cutting edge of tool, see explanation page 12.

6. **FACING THE ENDS.** To face the ends of bracket, see illustration Figure "R," page 56. This operation is further described on page 13, "Facing End of Shaft." After the end is faced true, remove the common dog, and attach a Clamp Dog to the cored end of bracket, (see drawing Figure "O," page 56) and face the solid end of shaft.

7. **TURNING.** Let the clamp dog remain attached to the cored end of bracket, and place the job on lathe centers. Select a diamond point turning tool, and take a roughing chip (see illustration Figure "O," page 56) the full length of the bracket. Always adjust the depth of the roughing cut so the cutting edge of tool will be underneath the scale.

8. **STRAIGHT TURNING.** After the first, or roughing chip has been taken, caliper the turned part at both ends, to see that the piece is machined straight or parallel. If there is any tendency to turn taper, adjust the tail stock center in the proper direction. For straight and taper turning, see Section 46 of book "How to Run a Lathe."

9. **FINISHING.** The machined part of this bracket is to be turned and finished to $\frac{3}{4}$ " diameter, in order to pass through a $\frac{3}{4}$ " hole in the grinder rest bracket "L," shown on page 19; this may be seen better in half-tone on page 2. It is, therefore, better to defer finishing chip until the holes in all four rest brackets have been bored. Leave diameter of the turned part of the rest bracket about $\frac{1}{32}$ " over size, so when the holes in all rest brackets are bored, the shanks may be turned to the proper size, in order to make a good fit in the holes.

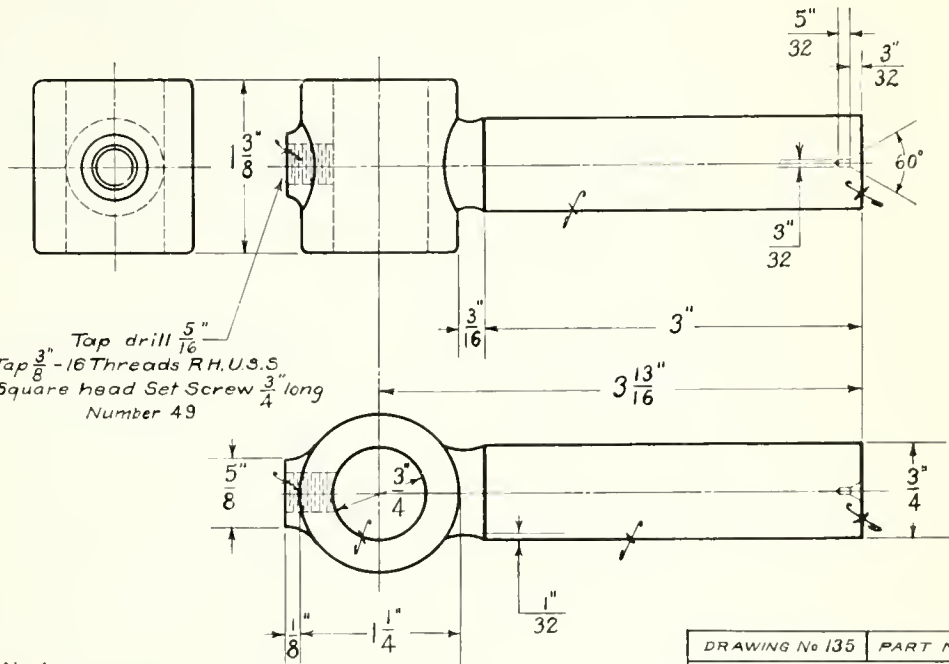

Job No. 1
 Material—Cast Iron
 No. Pieces Required—1

DRAWING No 135	PART No. 35
GRINDER T REST BRACKET.	
Scale-----Work to figures	
SOUTH BEND LATHE WORKS.	

Job No. 2. Part No. 37. Drawing No. 137.

1. Machine Job No. 2 in the same way as Job No. 1, as the instructions of Job No. 1 will apply in every way to Job No. 2; the only difference being the shaft or shank of Job No. 2 is the longer.

2. FINISHING. After taking the first or roughing chip on the diameter of shank, care should be taken to see that it is being turned parallel. If the cutting tool is at all dull, it should be sharpened, and the cutting edge rubbed with an oil stone, by hand. For calipering the turned part, an ordinary spring caliper may be used, but a micrometer caliper is recommended, for it immediately shows the operator how much material is left over the finished dimensions.

Drilling and Tapping Brackets

3. DRILLING. We shall here describe the method of drilling and tapping the cored end of the four brackets for the $\frac{3}{8}$ " set screws, but we shall have to postpone this operation until the three brackets are turned and bored complete. This drilling must be the last operation, for the reason it removes the center.

To drill the $\frac{3}{16}$ " hole in the end of bracket,

place the bracket in a Chuck, (see Figure "D"). The machined part of this bracket should run true when the chuck revolves. Adjust the jaws of the chuck accordingly, until the bracket does run true. Place a Standard Drill Chuck in the tail stock of the lathe. With a $\frac{3}{16}$ " Drill in the chuck, start the lathe and drill the hole.

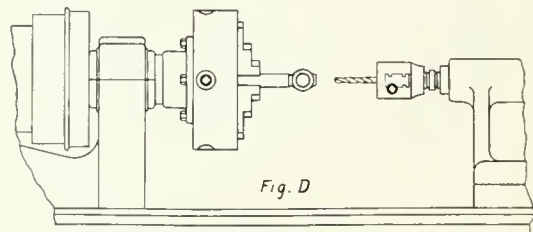

4. TAPPING. Remove the bracket from the chuck, and fasten it upright in a vise. Select a $\frac{3}{8}$ ", 16-thread, right hand U. S. Standard Taper Tap, and with a hand tap wrench, tap the hole. Be sure to keep the tap straight, or parallel to the axis of the bracket. Use a few drops of oil on the tap thread.. Remove the taper tap and follow with a plug tap.

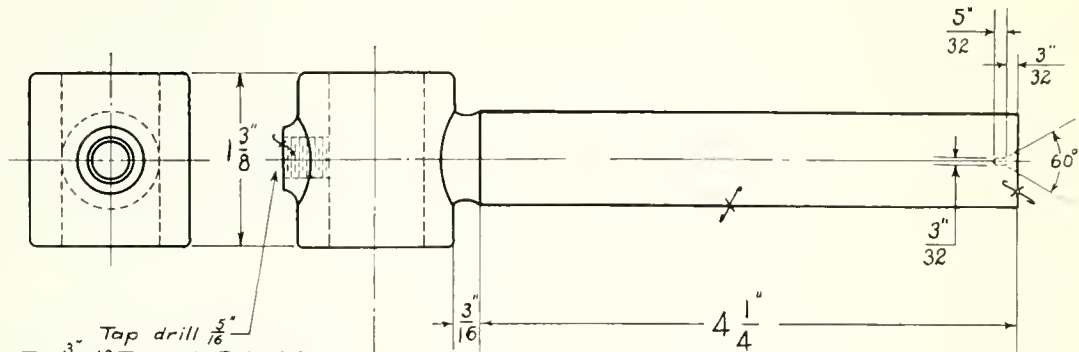

Tap drill $\frac{5}{16}$ "
 Tap $\frac{3}{8}$ "-16 Threads R.H. U.S.S.
 for Square head Set Screw $\frac{3}{4}$ " long.
 Number 49

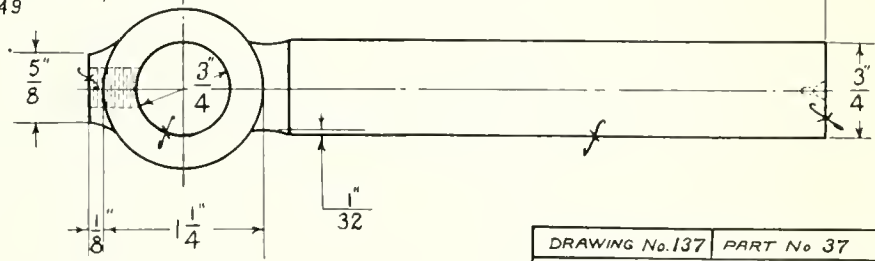

Job No 2
 Material- Cast Iron
 No Pieces Required - 1

DRAWING No. 137	PART No 37
GRINDER ANGLE REST BRACKET	
Scale ----- Work to figures	
SOUTH BEND LATHE WORKS.	

Job No. 3. Part No. 33. Drawing No. 133.

1. Machine Job No. 3 in the same manner as Jobs No. 1 and No. 2, as the instructions applying to Jobs No. 1 and No. 2 will also apply to Job No. 3, for it is similar, except that the shank of shaft in Job. No. 3 is longer than either one of the other two.

2. When machining a job on centers, the tail stock center should be oiled carefully. This center has been hardened and tempered, so the job revolving on this hard center, requires lubrication.

Boring the Brackets

3. BORING THE HOLE. We describe herewith the method of boring the $\frac{3}{4}$ -inch hole in the brackets of Jobs No. 1, No. 2 and No. 3. This hole may be bored any time after the four brackets are rough turned.

Place a drill pad in the tail stock spindle, and a drill chuck in the head spindle. Use a $47/64$ " drill in the chuck. The bracket to be drilled should be held in position as shown in drawing, Figure "Z" herewith. Note there is a small piece of $\frac{1}{2}$ " board between the bracket and the drill pad. The reason is so that when the drill passes through the bracket, it will finish in the wood, not in the drill pad.

The drill should revolve slowly. Operate the feed by hand wheel of tail stock, and feed slowly, especially when the drill reaches within $\frac{1}{16}$ " of the end of the hole. It is not necessary to hold the

bracket by hand while being drilled, but to let the end of bracket rest on top of compound rest, as shown in drawing Figure "Z."

When the $47/64$ " hole is drilled in all four brackets, remove the drill and replace it with a $\frac{3}{4}$ " Standard Reamer. The reaming operation is almost similar to that of the drilling, except that the reamer should revolve slower and the work should be fed to the reamer more slowly than in drilling.

Another, but a more difficult way to do this job, would be to clamp the bracket to the face plate, and machine with a boring tool.

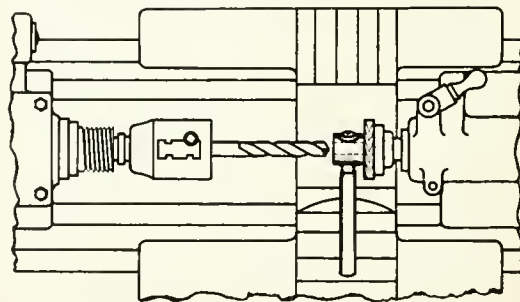
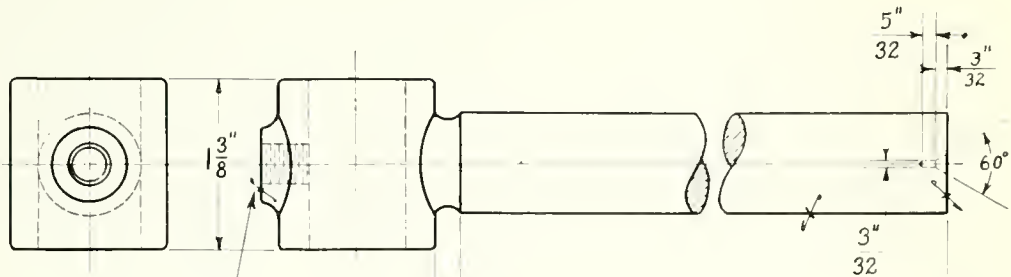
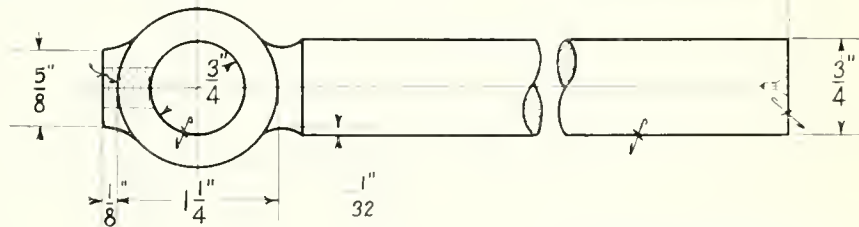

Fig. Z



Tap drill $\frac{5}{16}$ "
 Tap $\frac{3}{8}$ " - 16 Threads R.H. U.S.S.
 for Square head Set Screw $\frac{3}{4}$ " long
 Number 49



Job No. 3
 Material - Cast Iron
 No. Pieces Required. - 2

DRAWING No. 133	PART No. 33
GRINDER REST BRACKET L.	
Scale ----- Work to figures	
SOUTH BEND LATHE WORKS.	

Job No. 4. Part No. 31. Drawing No. 131.

1. CENTERING. To locate the centers on Job No. 4, see drawing Figure "M," page 6.

2. DRIVING. Owing to the construction of the "T" Rest, we cannot drive it with either the common lathe dog or the clamp dog, so it is necessary to attach a stud to the face plate, as per drawing herewith. This stud is simply a short piece of steel, about $\frac{1}{2}$ " diameter, 3" long, threaded on one end for the distance of 2". By using two standard nuts, this stud can be clamped firmly to the face plate (an ordinary machine bolt, $\frac{1}{2} \times 3$ ", will serve). Note this stud should not extend any farther than the part of the casting which it drives. The reason is so the revolving stud will not interfere with the carriage of the lathe during the turning operation.

3. FACING. The shaft end of the "T" Rest only is to be faced.

4. TURNING. With the "T" Rest on centers, place a diamond point tool in the tool post, and take a light turning chip the entire length of the round part or shaft of the "T" Rest. Caliper for parallel turning. Then take a second chip, but do not finish any closer than $\frac{1}{32}$ " to the $\frac{3}{4}$ " dimension, because shaft of this "T" Rest should not be

finished until the hole is bored in the "T" Rest Bracket, Part No. 35, or Job No. 1.

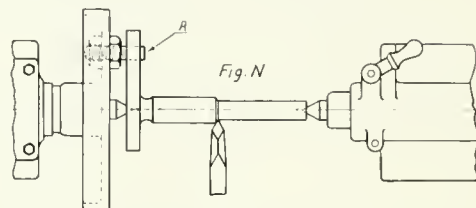

There are several dimensions shown in "T" Rest Bracket, Job No. 4, that are not required for machining. Most of these dimensions are to be followed only for making the pattern for the "T" Rest.

Tie with Belt Lace

When driving a job on centers by a stud bolted to the face plate instead of a common lathe dog, the job should be tied to this stud with a piece of belt lacing. This is especially true when filing or polishing a piece that is revolving at a high speed on centers.

A good lathe hand can run any kind of a machine.

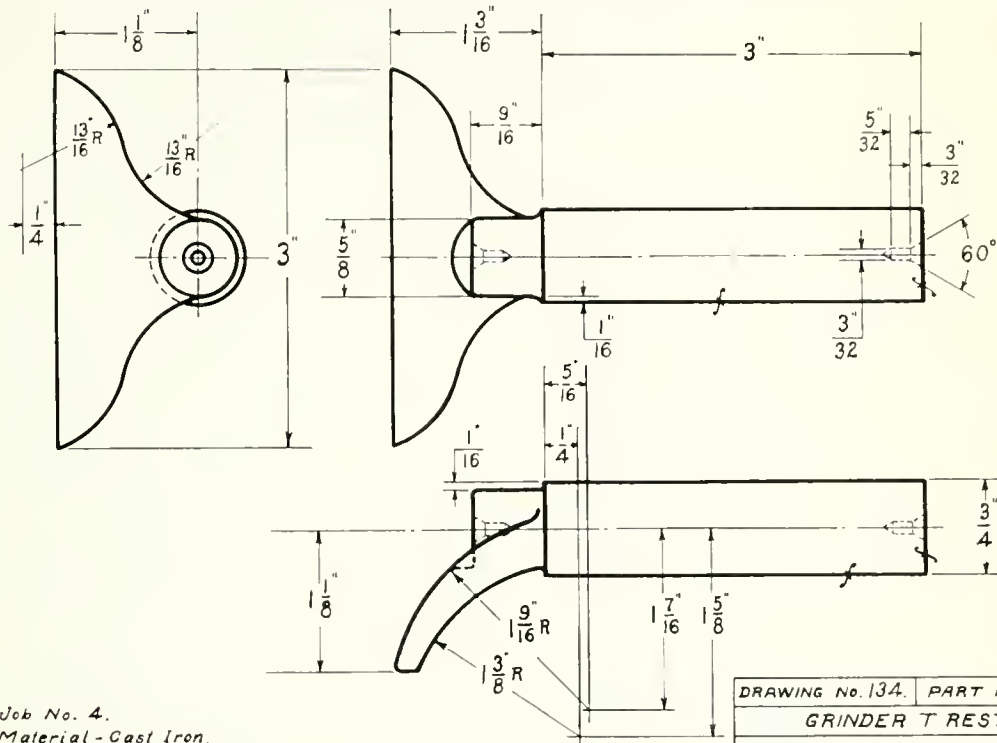

Job No. 4.
 Material - Cast Iron.
 No. Pieces Required - 1.

DRAWING No. 134.	PART No. 34.
GRINDER T REST	
Scale ----- Work to figures.	
SOUTH BEND LATHE WORKS.	

Job No. 5. Part No. 36. Drawing No. 136.

1. CENTERING. To center Job No. 5, follow instructions shown in Job No. 4.

2. DRIVING. For driving Job No. 5, follow instructions described in Job No. 4.

It will be noticed in Jobs No. 4 and No. 5, they are faced only on the shaft end.

Do not take a finishing cut on Job No. 5, but allow $1/32$ " stock for finishing at a later cut, after bracket in which angle rest fits is bored.

Turning A Diameter to Fit A Machined Hole or Gauge

In turning a round shaft to fit a cylinder or hole, we should first learn what kind of a fit is required. There is a tight, driving fit, such as is required for an arbor. There is a pressing fit, such as is required for an inside flange on a grinder spindle, and there is a loose fit, which is the one we require on jobs No. 1, No. 2, No. 3, No. 4 and No. 5.

We cannot fit the round end or shank of the bracket to the hole in the rests, Jobs No. 1, No. 2 and No. 3, until these holes have been machined. We therefore leave the round part or shank of the bracket about $1/32$ " larger in diameter, until we are ready to make the fit.

When the holes are bored, caliper the exact diameter of the hole. Or, better still, select an arbor which will fit the round hole. Then caliper the arbor at a point where it fits the hole. This will be the exact size of the shanks of the Angle Rest, T Rest and Brackets.

When ready to make the fit, place the job on centers and take a light chip, not extending over $1/4$ " from the end of bracket. Caliper the reduced diameter carefully, and also try it in the hole for which it is to be fitted. If you can enter the shaft $1/16$ " into the hole, by pressure, then you can finish the chip.

Change the belt, so the spindle will run at highest speed, put a couple drops of oil on the tail center, and with a file, smooth the end of the bracket for a distance of about 1". Then remove the bracket from centers, and try it in the hole. It should be a nice, twisting fit, not too loose, but just so it will slip through nicely without shaking.

Care must be taken to see that the hole into which the bracket fits is true. We assume, of course, this has been finished with a reamer. If so, it is finished to size, without any burrs or rough edges.

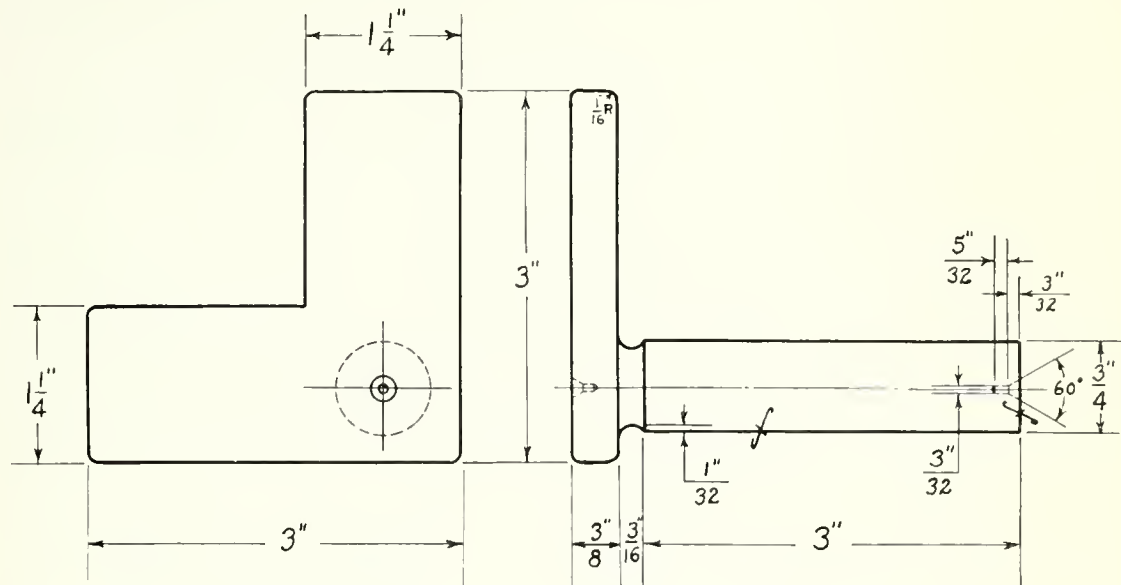

Job No. 5.
 Material - Cast Iron
 No. Pieces Required - 1

DRAWING No. 136	PART No. 36
GRINDER ANGLE REST	
Scale ----- Work to figures	
SOUTH BEND LATHE WORKS.	

Job No. 6. Part No. 31. Drawing No. 131.

1. MATERIAL. Secure a piece of mild steel, about $1\frac{1}{4}$ " diameter, $13\frac{1}{2}$ " long, and machine so that it will finish to the dimensions indicated in drawing.

Before centering, see that the shaft is straight. If it is bent or twisted in any way, straighten it. After you have located the center marks, place the shaft on centers and revolve it by hand. When it is running as nearly true as possible, then drill center holes.

2. CENTERING. For centering, follow instructions in Job No. 1, except that in centering a piece of steel, oil should be used on the center drill.

3. TURNING. Select a common dog of suitable size. Face both ends of shaft, then with a diamond point tool take a rough turning cut on the diameter, allowing the tool to cut within about 3" of the dog. Then transpose the dog and shaft, run the tool back, and complete the roughing cut on the opposite end.

In turning a long shaft, it is very necessary that the machined or turned part is parallel. This should be tested carefully, and if any taper is indicated, tail stock should be adjusted and a light chip taken, until the piece is exactly parallel.

It is necessary that the student finish Job No. 6 exactly to the dimensions shown in drawing so he may become familiar in working accurately to dimensions.

Job No. 6 is now machined in the rough, and is to be further machined as the grinder spindle, as shown in Jobs No. 7, No. 8 and No. 9. Note the depth of the centers shown in drawing, and see that your centers conform to these dimensions.

In turning a piece of steel, it will be noticed that the chips curl more, and that the tool becomes heated more, than in turning cast iron; therefore, a little slower speed should be used, and the turning tool should be watched more carefully, to see that it does not dull.

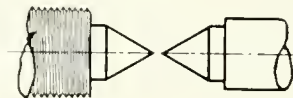

Before machining a piece on centers in the lathe, see that the centers line up, as per cut herewith. For further description see Section 46 of Lathe Book.

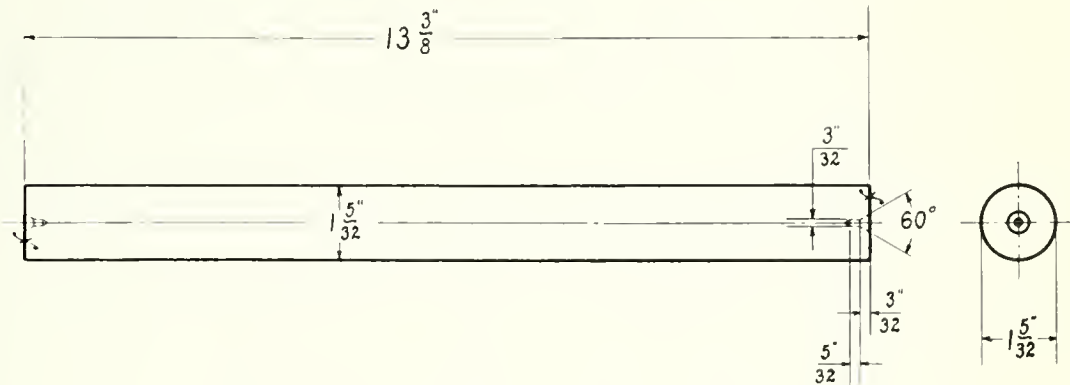

Job No. 6

Material - Mild Steel.

No. Pieces Required - 1

DRAWING No. 131 PART No. 31

SPINDLE

Scale _____ Work to figures

SOUTH BEND LATHE WORKS.

Job No. 7. Part No. 31. Drawing No. 131-A.

1. MATERIAL. For Job No. 7 use the shaft that has been machined in Job. No. 6.

Take a turning chip that will reduce the diameter within $\frac{1}{32}$ " over size, the entire length of spindle. The large diameter of this spindle is to be fitted to spindle pulley, but we cannot do this fitting until the spindle pulley is machined.

2. LOCATING THE SHOULDERS. When we reduce a shaft in diameter at one or more places, we use a cutting-off tool to locate the shoulder. (See illustration Figure "T," page 56.) Fasten the cutting-off tool in the tool post. Be sure to see that the tool has clearance on both sides. Move the cutting-off tool until the farther side is $3\frac{1}{8}$ " from the end of shaft, that is, within $\frac{1}{16}$ " of the finished length. Now start the lathe, and with a spring caliper in the right hand, and left hand feeding the cutting-off tool forward, take a light chip, using oil on the cutting edge of the tool. Feed carefully until the proper diameter is reached, which will be indicated by the caliper. This diameter should be about $\frac{1}{32}$ " larger than the finished size. Then withdraw the tool, transpose the driving dog and shaft, and repeat the shoulder operation on the other end of shaft. Locate the two inside shoulders in the same manner.

3. TURNING. With a Turning Tool, reduce each end of the shaft to about 1.64 " larger in di-

ameter than the dimensions called for. Then take a chip over the center of the grinder shaft, reducing the diameter to about $1/32$ " larger than the drawing calls for.

4. TURNING FOR THREAD, WHEEL, AND FLANGE DIAMETER. Note that the length of thread is $1\frac{1}{2}$ " from either end of spindle, but that the $\frac{3}{4}$ " diameter extends $2\frac{7}{16}$ " from the end. This dimension includes the length of thread, plus thickness of emery wheel and outside flange. The diameters $.752$ " for press fit are to accommodate the inside flanges, which should fit fairly tight on the shoulder. This diameter we cannot machine to a finish until inside flanges are bored. (See Job No. 12, page 37.) The two bearings are 1 " in diameter and $2\frac{9}{16}$ " long. These can be finished to size at any time. The $1\frac{1}{8}$ " diameter is for the pulley. This diameter should not be finished until the pulley has been bored. (See Pulley Job No. 10, page 32.)

5. As we cannot finish the press fit for the inside flanges, nor the diameter where pulley fits, until the flanges and pulley are machined, we can go ahead with the thread cutting. If the student has had no experience in thread cutting, we suggest that the instructor secure a number of pieces of $\frac{3}{4}$ " shafting, about 6 " long, and have each student practice cutting short threads on one of the shafts before he attempts cutting the thread on spindle.

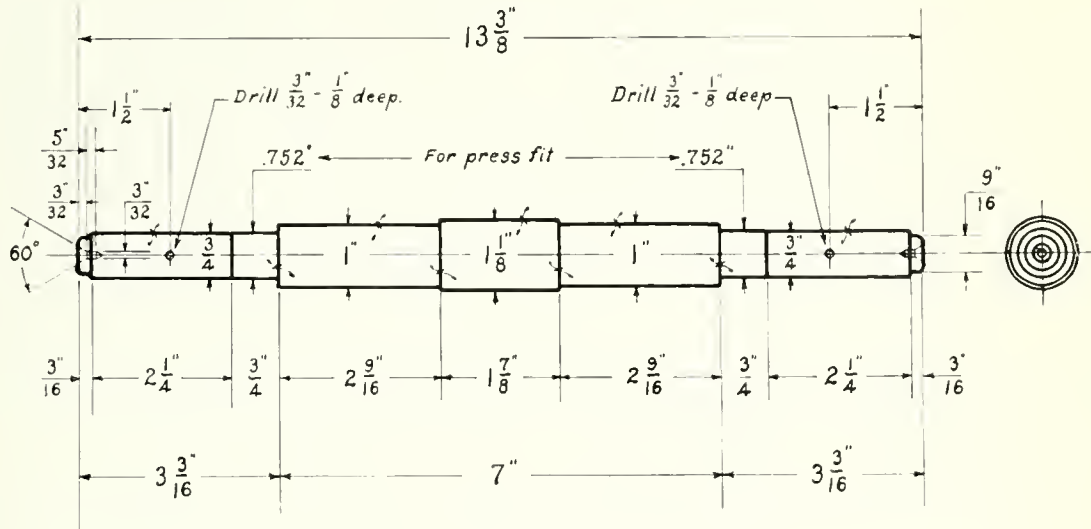

Job No. 7
 Material - Mild Steel.
 No. Pieces Required - 1

DRAWING No. 131-A	PART No. 31
SPINDLE	
Scale _____ Work to figures.	
SOUTH BEND LATHE WORKS.	

Job No. 8. Part No. 31. Drawing No. 131-B.

1. MATERIAL. For Job No. 8 we use the shaft machined in Job No. 7. Cut a $\frac{3}{4}$ " x 10 U. S. Standard Thread, right hand, on one end.

2. GEARING LATHE. For thread cutting see Sections 38 and 39 of Lathe Book for selecting gears to secure the desired pitch. Also see Rule, Section 45, of Lathe Book: "Gearing Any Engine Lathe for Screw Cutting."

3. SETTING THE THREAD TOOL. For setting the thread tool, see Section 40 and 41 of Lathe Book. We recommend a tool similar to the Patent Threading Tool, shown in Section 29 of Lathe Book.

4. LENGTH OF THREAD. The length of thread to be cut, as shown in drawing, is $1\frac{1}{2}$ ". Measure this distance from the end of the shaft, and make a prick punch mark. Then, with a $\frac{3}{32}$ " drill, drill a hole $\frac{1}{8}$ " deep, using this prick punch mark as a center. Attach a common lathe dog to the grinder spindle, and place it on the centers. Be sure to put oil on your tail center, and clamp the tail spindle. Now set the threading tool, with the point opposite center of the hole you have just drilled, where the thread terminates. Then with a center gauge, line the tool up properly as in Section 41 of Lathe Book, drawing Figure 15. The height of the cutting edge of the threading tool should be even with the axis or point of the

lathe center. Fasten the thread-cutting stop to the saddle, as explained in Section 40 of Lathe Book. Clamp the half nuts on the lead screw, reverse the countershaft. This will run the carriage back until the thread cutting tool reaches about $\frac{1}{8}$ " beyond the end of the grinder spindle.

5. FIRST CHIP. Before taking the first chip, study Section 42 of Lathe Book. See that the lathe dog is fastened securely to the grinder spindle, and that the threading tool is fastened; then proceed with the first chip, allowing the tool to just merely scratch the spindle. Stop the lathe before the tool reaches the hole, showing the end of cut. This hole was drilled so as to allow the tool to finish the end of each chip. Then finish the chip by turning the spindle cone slowly forward, by pulling on the belt by hand.

6. In removing a threaded piece from the lathe for testing the thread, never detach the dog from this piece. Do not even change the position of the dog. Always mark the slot in the face plate in which the dog was placed, while the thread is being cut. Replace the tail of the dog in the same slot, when you put the job back on centers to renew the thread cutting. For testing thread, see instructions in Job 9.

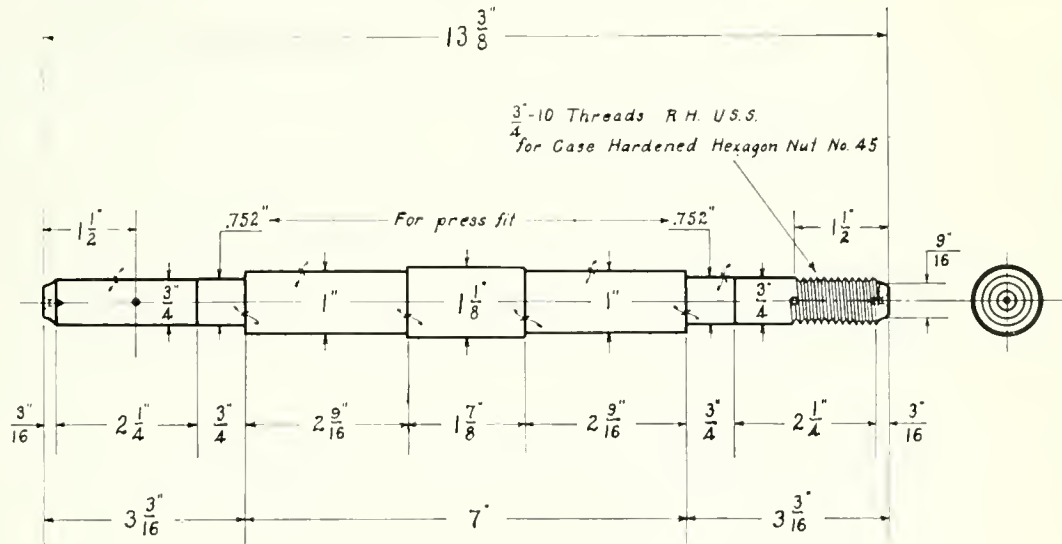

Job No. 8

Material - Mild Steel.

No. Pieces Required - 1

DRAWING No. 131-B	PART No. 31
SPINDLE	
Scale _____ Work to figures	
SOUTH BEND LATHE WORKS.	

Job No. 9. Part No. 31. Drawing No. 131-C.

1. MATERIAL. For Job No. 9 we use the spindle machined in Job No. 8. We are to cut a $\frac{3}{4}$ " x 10 U. S. Standard Thread, left hand, on the other end of spindle. For cutting this thread, we use the same arrangement of gearing as we did for cutting the thread in Job No. 8.

2. CUTTING LEFT HAND THREAD. Do not let the screw of the dog come in contact with the thread, but select an old nut $\frac{3}{4}$ " x 10" right hand thread. With a hand hack saw, split one side of the nut through into the hole, and half way into the other side. Then place this nut on the threaded end of shaft and fasten securely with a clamp dog. In this manner we can drive the threaded shaft without injuring the thread.

3. THREAD TOOL. Use the same thread tool and set in the same manner as you did in Job No. 8.

4. LENGTH OF THREAD. Drill a hole about $\frac{3}{16}$ " in diameter, and about $\frac{3}{16}$ " deep, $1\frac{1}{2}$ " from the end of the spindle. This hole will be the starting point of each chip in cutting the left hand thread. Adjust the reverse lever in the head stock, so that when the split nut is clamped on the lead screw and the shipper rod is thrown forward toward the head end of the lathe, the spindle cone of lathe will revolve, the top of the cone rotating in the

direction of the operator. Then the carriage should feed from left to right.

5. CUTTING THE THREAD. Set your thread tool and use the adjustable stop exactly as you did in Job No. 8, and proceed with the first chip. The carriage will now move to the right instead of the left, and when the thread tool reaches a point at least $\frac{1}{8}$ " beyond the end of spindle, reverse the shipper rod. This will reverse the direction of travel of the carriage until the thread tool reaches the hole or starting point. Then arrange for depth of second chip. Start in carefully, taking a light chip. Continue this operation until the thread is finished. Use plenty of oil on the thread tool; lard oil is preferred.

6. TESTING THE THREAD. Use the nut intended for the threaded part as a gauge. When you think the thread about finished, remove the spindle from centers, and try the nut on thread. Do not strain the thread, the nut should go on half of its depth with very little pressure. Examine the thread after you remove the nut, to see if the thread has a perfect bearing.

When the thread is cut on both ends of the spindle, chamfer off the ends as shown in drawing.

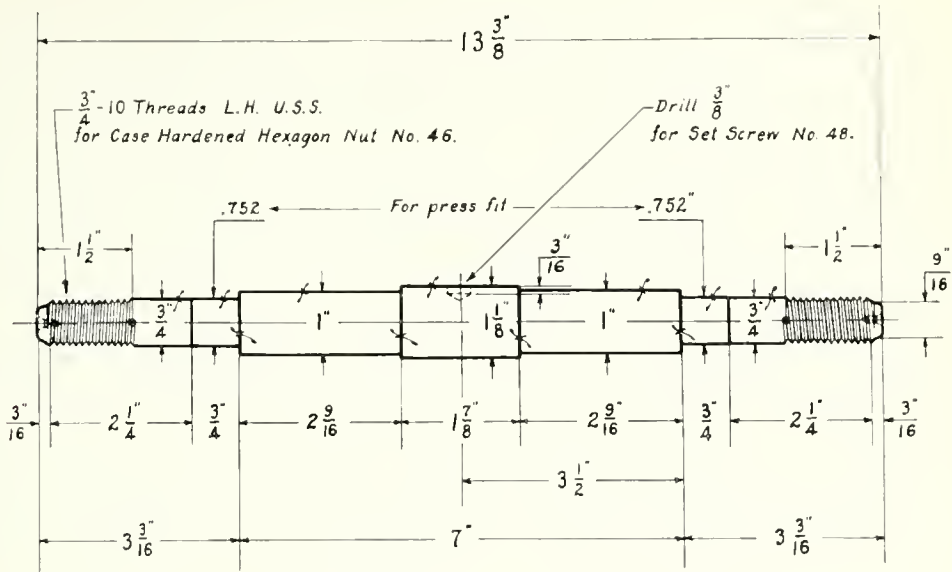

Job No. 9
 Material - Mild Steel.
 No. Pieces Required - 1

DRAWING No. 131-C		PART No. 31
SPINDLE		
Scale ----- Work to figures.		
SOUTH BEND LATHE WORKS.		

Job No. 10. Part No. 32. Drawing No. 132.

1. **JOB.** A cast iron pulley is to be machined to the dimensions as shown on drawing.

2. **CHUCKING OPERATION.** Attach a 6", 3-jaw Universal Geared Scroll Chuck to the spindle nose of lathe, and fasten the casting in the chuck. (See explanation drawing Fig. K, page 58.)

3. **FACING.** Use a round nose tool, and face the end of pulley to the depth of about $\frac{1}{16}$ " below scale.

4. **CENTERING.** Place a centering tool in the tool post, and locate the center of the pulley, adjusting the tool so that it is approximately at the center. Take a light chip, moving the tool so that when it begins to cut, it will show the exact center, and will machine a countersunk hole about $\frac{1}{8}$ " deep. (See drawing, Section 78, page 58, Lathe Book.) The hole in this pulley could have been cored but we left the casting solid, for practice.

5. **DRILLING.** Use a 1" Straight Shank Twist Drill, held by a drill chuck in tail spindle. Drill a hole through the pulley, feeding by hand wheel of tailstock.

6. **BORING.** With a boring tool, take a chip about $\frac{1}{32}$ " through the pulley, or deep enough to true up the hole. Follow with another finishing chip about $\frac{1}{64}$ " deep. Then follow with a reamer, reaming the hole to size. It should be borne

in mind that this pulley is to fit the spindle. (See Job No. 9.)

7. **FINISH ON ARBOR.** Remove the pulley from the chuck, and press it on to a $1\frac{1}{8}$ " arbor; the arbor entering the hole at the machined end of pulley. Place a drop of oil or grease on the arbor, and spread it thoroughly with the hand, so when the pulley is machined, the arbor may be pressed out easily. Never place a steel arbor into a cast iron piece, unless either the hole or the arbor has been oiled slightly, because if it has not been lubricated, the pulley is liable to cut when driving it off the arbor.

8. Attach a dog and place the job on centers. (See drawing Figure "V," page 57, Pulley on Arbor.) Take a roughing cut over the diameter of pulley, and face up both ends to the proper dimensions.

9. **TURNING TAPER.** Set the tailstock off center, to get the required taper or crown of pulley. (See Section 46 of Lathe Book.) After required taper is found, take a chip off of one end. Then remove the dog, and place it on the opposite end of the arbor. Place the job back on centers, and take a chip on this end. Repeat the operation until the pulley is machined to the proper dimensions.

Tap drill $\frac{5}{16}$
 Tap $\frac{3}{8}$ - 16 Threads R.H. U.S.S.
 for Headless Set Screw $\frac{3}{4}$ long No. 48

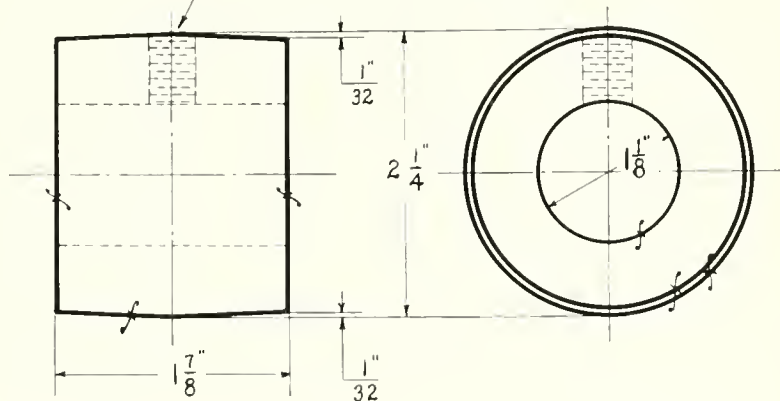

Job No 10
 Material - Cast Iron.
 No. Pieces Required - 1

DRAWING No 132	PART No 32
SPINDLE PULLEY	
Scale ----- Work to figures.	
SOUTH BEND LATHE WORKS	

Job No. 11. Part No. 39. Drawing No. 139.

1. Mount a 6", 3-jaw Universal Geared Scroll Chuck on the lathe. Fasten the flange casting in chuck, gripping it by the small shoulder. (See illustration Figure "S," page 57.) Be sure to see that the flange runs true, not only on the outside diameter, but the hole should also run true. If the hole is not concentric with the outside diameter of the flange, then measure the amount of stock to be removed from hole, and the amount of stock from the outside diameter of the flange, and adjust the chuck so that both the hole and outside diameter can be machined true in the same chucking.

When the flange runs true in the chuck, with a round nose tool, take a roughing chip on face of flange; then a finishing chip. Then a slight roughing chip on large diameter of flange, and a finishing chip. Adjust round nose tool and take a recessing chip on face of flange. (See Figure "S," page 57, Tool "B.") Place a boring tool in the tool post (see Tool "C") and take a roughing chip through hole; then a finishing chip, until within $1/64$ " of size. Then finish with a $3/4$ " Standard Reamer.

2. TURNING FLANGE ON ARBOR. Remove flange from the chuck, and press it tightly on a $3/4$ "

arbor. Attach a dog to the arbor, and place the job on centers. Set the compound rest on an angle of 13-degrees. (See illustration Figure "H," page 57.) Use a tool having a very small round nose, and take a roughing chip on the angle part of flange; then a roughing chip on the diameter of flange and hub; then a finishing chip on both flange and hub. With a side tool, face the small hub and inside of flange.

3. FILING AND POLISHING. Allow the job to remain on centers, and release the tail stock center slightly, so the arbor will run perfectly free. Put a drop of oil on the tail center point. Run the lathe spindle at next to the highest speed, and with a mill file, smooth up carefully the outside diameter, the angle surface, and the small hub of flange. You may round the corners slightly, but not the corner of the large diameter of the face of flange.

To polish a piece of cast iron in the lathe, take a strip of emery cloth about the width of a file, put a few drops of oil on the cloth. Then holding the cloth against the file, polish the flange while it is revolving. Keep plenty of oil on the emery cloth. This will produce a fine, polished surface, and the oil will prevent rusting.

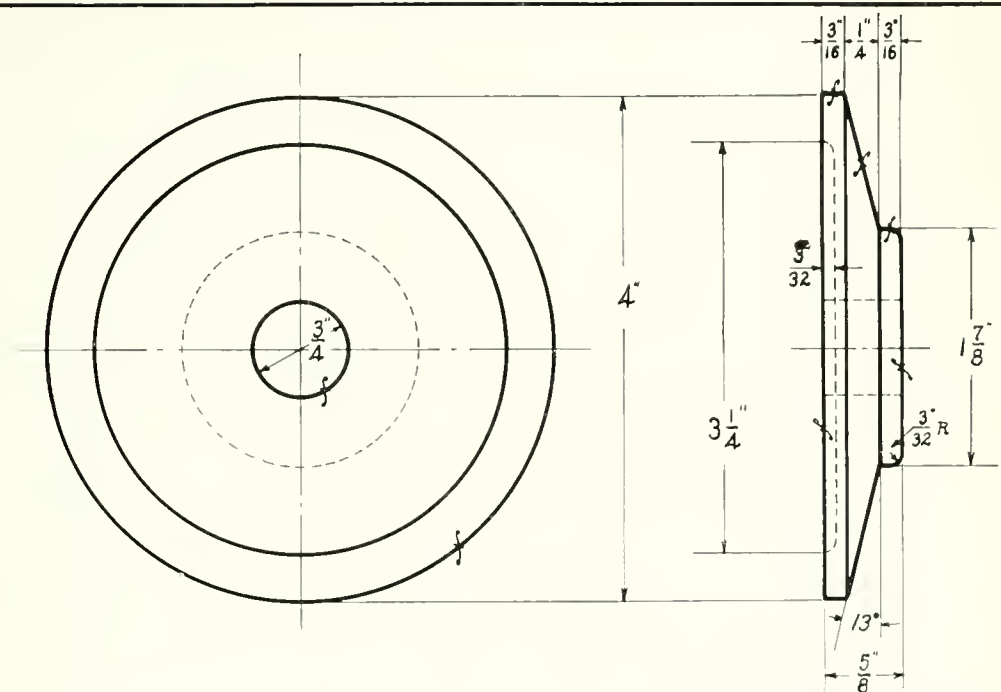

Job No. 11
 Material - Cast Iron
 No Pieces Required - 2

DRAWING No 139	PART No 39
OUTSIDE FLANGE	
Scale - - -	Work to figures
SOUTH BEND LATHE WORKS.	

Job No. 12. Part No. 38. Drawing No. 138.

For machining Job No. 12 follow instructions given in Job No. 11, except that the flange angle on Job No. 12 is 10 degrees, while Job No. 11 was 13 degrees. Also note that Job No. 12 has a grooved hub, while the hub on Job No. 11 was plain.

When the flange has been machined and is still on arbor, with a $\frac{3}{16}$ " round nose tool, machine a groove $\frac{3}{16}$ " wide and about $\frac{3}{32}$ " deep, in the center of hub, as shown in drawing. The object of this groove is to prevent the oil from the bearings from running up on the flange, while the emery wheel is in motion. File and polish the flange as described in Job No. 11.

After a job has been bored in a chuck, and then placed on an arbor, all surfaces should again be machined if an accurate job is required.

The inside flanges for the grinder spindle should fit up close to the shoulders of spindle, so that when assembled on the spindle and placed in the grinder head, there should be a slight play between the hubs of the two flanges and the outer ends of bearings on head; that is, there should be a visible slight end motion, not exceeding $1/64$ ".

Removing a Job from Arbor

In removing a job from the arbor, or driving the arbor out of the job, care should be taken to see that the arbor is driven out of the job from the small end, as one end of all arbors or mandrels is smaller than the other end. The size of the mandrel is usually marked on the large end.

In driving a mandrel into or out of a pulley, be careful not to batter or jamb the end of the arbor, because if the center hole or outside diameter of the arbor is battered, then the arbor will not run true, and if the arbor does not run absolutely true, you cannot machine an accurate job on it. A babbitt hammer or a wooden mallet would best serve as a driver. A small cast iron anvil, similar to that shown in Figure "W" herewith, would make an excellent anvil for arbor work, and it will also be found useful for other work in the machine shop.

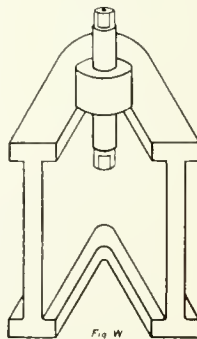

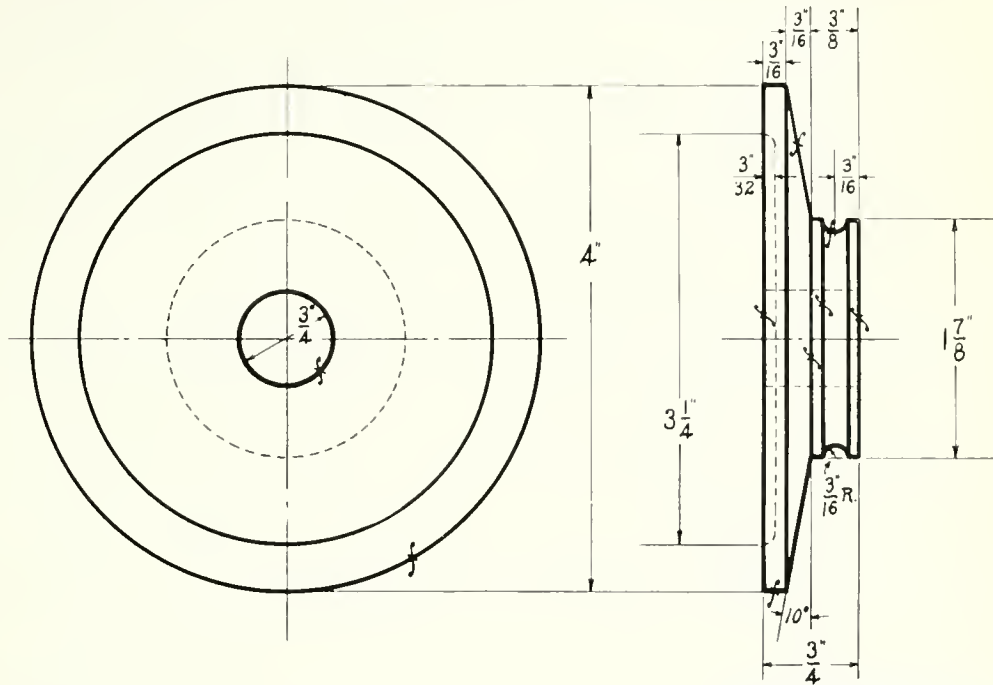

Job No. 12
 Material - Cast Iron.
 No. Pieces Required - 2

DRAWING No. 138 PART No. 38

INSIDE FLANGE

Scale _____ Work to figures.

SOUTH BEND LATHE WORKS.

Job No. 13. Part No. 30. Drawing No. 130.

1. Drawings on page 39 show the grinder head caps.

2. Clean the casting and remove all sand and grit.

3. The six anchor holes "B" should be drilled according to drawing, so that when the babbitt is poured, it enters these holes, and there forms an anchor to hold the babbitt in the cap. Drill the six anchor holes in each cap, also six similar anchor holes for holding the babbitt for each bearing in the grinder head.

4. Locate the position of the cap screw holes for attaching caps to grinder head. Note that the centers of these holes are $2\frac{1}{8}$ " apart. Chalk the surface where the holes are to be drilled. Rub this chalked surface with the finger, and with the dividers locate the centers of the boss of each hole. Make a prick punch mark at each center, and scribe a $\frac{3}{8}$ " circle. Make six prick punch marks on the circumference of each circle, (see drawing Fig. "U"). Next make a deep center punch mark on the center of each circle. The center distance should be $2\frac{1}{8}$ ".

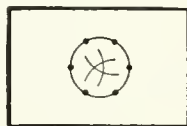

Fig. U

5. Use a $\frac{3}{8}$ " drill in the chuck in head spindle, and a drill pad in the tail stock. Let the point of the drill enter about $\frac{1}{16}$ " in each circle. See if the hole is going to be concentric with the circular lay-out. If it is not, then with a prick punch drive the center of the hole in the proper direction in order to be concentric. Remove a little more stock with the drill, and test again. When the drill hole is concentric with the lay-out, drill both holes. Now with a counterbore, having a $\frac{3}{8}$ " pilot, remove $\frac{1}{32}$ " stock, so that the head of the cap screw will rest on a machined surface.

6. Locate the hole in the top of cap for oil cup. This hole should be in about the center of the boss. Use a $17/64$ " drill.

Do not tap the oil hole at this time, because it is through this hole that the babbitt is poured. After babbitt is poured, then redrill this hole, removing the babbitt, and tap for oil cup.

7. Some of the holes drilled in grinder and cap could perhaps be done to better advantage on a drill press. Our instructions are to drill these parts in the lathe, assuming that there is no drill press in the shop equipment.

Drill $\frac{1}{8}$ " dia. for
Babbitt vent.

Tap Drill $\frac{17}{64}$ " Tap $\frac{5}{16}$ "-32 Thds
R.H.U.S.S. for Oiler No. 50.

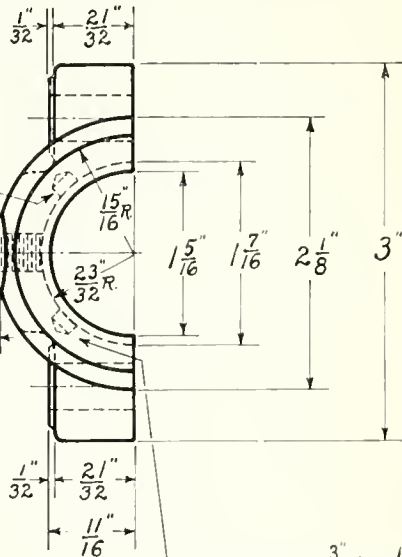
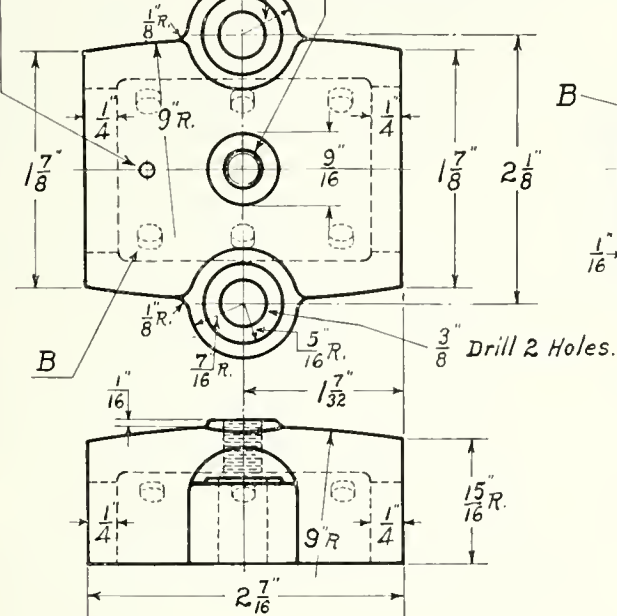

Drill 6 holes $\frac{3}{16}$ " dia. $\frac{1}{8}$ " deep
for anchoring babbitt.

Job No. 13
Material - Cast Iron.
No. Pieces Required - 2

DRAWING No. 130	PART No. 30
HEAD CAP	
Scale _____ Work to figures.	
SOUTH BEND LATHE WORKS.	

Job No. 14. Part No. 29. Drawing No. 129.

1. The drawing on page 41 shows three views of the grinder head casting, also an enlarged view of one of the boxes, or bearings.

2. Clean the casting thoroughly. Remove all sand, gates and sprues, inside as well as outside.

3. To drill the necessary holes in the grinder head, for lag screws to hold the grinder to the bench, and holes for safety guards, make a jig of wood, similar to that shown in drawing Figure "P," page 56. This jig should be about 12" long. Let it rest on two strips of wood, each about 2 feet long, so they will rest on the front and rear of lathe saddle.

4. The caps machined in Job No. 13 should now be fitted to the grinder head. Chalk the top of the grinder head where the holes are to be drilled for cap screws. Hold or clamp the cap firmly to the head, and with a scratch-awl mark through the holes in cap and locate the position of the holes on grinder head. When one hole has been located for each cap, remove the caps, lay out these holes with six prick punch marks on the circle, find the center of the circle, as per drawing page 38, and make a deep punch mark at this center. Then mark the right hand cap and right hand box with a prick punch, so you can replace cap on

its own bearing each time. Also make two center punch marks on the front on the other cap and box.

5. Use a $\frac{5}{16}$ " drill. Drill only one hole in each bearing. Tap the holes and fasten each cap with one screw. Then with a $\frac{3}{8}$ " drill, using the hole in the cap as a jig, spot the other hole for each cap in the grinder head, letting the point of the drill enter the casting only about $\frac{1}{16}$ ". Now remove both caps, and with a $\frac{5}{16}$ " drill, finish both holes. Tap both holes and attach both caps.

6. When the caps are attached, see that they fit nicely on the grinder head. They should not lap over, neither on the sides nor ends. If they do, remove the lap with a file.

7. If more than one grinder at a time is being made, number each cap and each bearing in serial, so you can attach each cap to its own bearing.

8. Locate the position of holes through which grinder is clamped to the bench, and drill them, (see drawing Fig. P, page 56). The position of the holes for safety guards can not be located until grinder is complete and the emery wheels attached. Then place the safety guards in position, so they fit properly over the emery wheels, and mark through the slots of the base.

ENLARGED VIEW OF BEARING BABBITTED

Tap Drill $\frac{5}{16}$ Tap $\frac{3}{8}$ -16 Thds R.H. U.S.S.
for 4 Fill Hd Cap Scs's $1\frac{1}{2}$ " Long No. 47

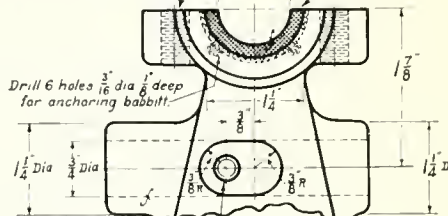

Tap Drill $\frac{5}{16}$ Tap $\frac{3}{8}$ -16 Thds R.H. U.S.S.
for 2 Self Screws $\frac{3}{4}$ " Long No. 49.

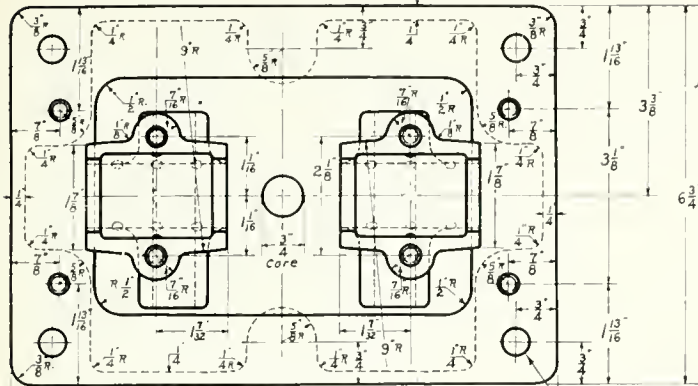

$\frac{33}{64}$ " Drill for 4- $\frac{1}{2}$ " x 3 Machine Bolts
No. 23 with Washers Number 25.

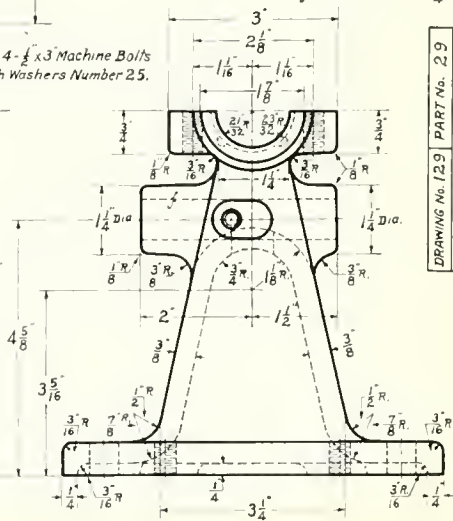
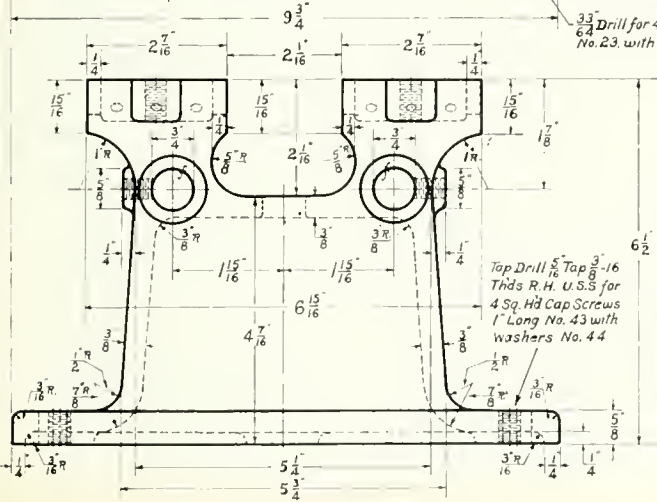

DRAWING No. 129	PART No. 29
GRINDER HEAD	
Scale	Work to figures
SOUTH BEND LATHE WORKS.	

Job No 14
Material - Cast Iron
No Pieces Required - 1

Job No. 16. Part No. Special.

Job No. 16 drawing shows the small parts that we use in the babbiting jig, which is described in Job No. 17.

Make four shims of cardboard, $\frac{1}{32}$ " thick. (See drawing on opposite page.) One of these shims is placed under each side of each cap to allow for wear, because after two or three years, when the spindle bearings wear, these shims are removed and thinner shims are inserted to take up the wear. The shims as shown do not indicate the holes for the screws. This is because we first use these shims as part of the babbiting jig, and afterward we cut the hole for the screw and use the shims in the grinder.

One of these shims shows an opening on one side, through which the babbitt is poured, as explained later.

The four cast iron collars shown are bored to 1" and faced on one end. They are also recessed $\frac{1}{32}$ " deep, $1\frac{1}{16}$ " diameter. The object of this recess is that when babbitt is poured, it will fill into this space, which will allow it to project $\frac{1}{32}$ " beyond the bearing.

The 1" cold rolled shaft, shown in drawing is what we call the babbiting bar. This shaft should be straight and true. It should be 1" in diameter, not .001" over or .002" less.

In placing this shaft in the babbiting jig, the center of shaft should be about $\frac{1}{64}$ " higher than the top of the bearing of grinder head. The reason is that the shim is $\frac{1}{32}$ " thick, therefore when the grinder spindle is fitted to the bearing, the center or axis of the spindle will be in line with the center of the shim.

Scraping the Boxes

After the bearings in grinder head have been babbitted, the bearings of the spindle being finished, place some red lead on the spindle bearings, and put the spindle in the grinder head; revolving it slowly by hand. This will show the high spots. Then with a scraper, using a half round file, ground smooth and with a cutting edge, scrape the high spots until the spindle has a thorough bearing.

This scraping should be done before the grinder caps are babbitted. After the grinder caps are babbitted, they should be tested and scraped in the same manner.

In babbitting a large bearing, we usually paint the babbitting shaft with graphite, in paste form, but the bearings of this grinder are small, and will not need a coat of graphite.

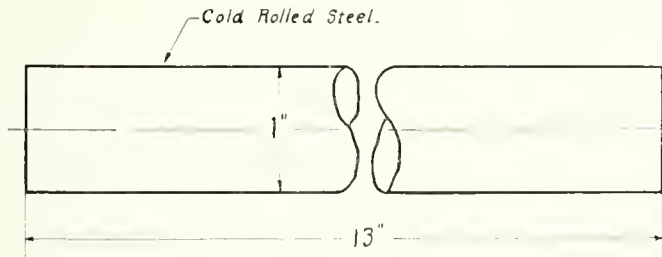
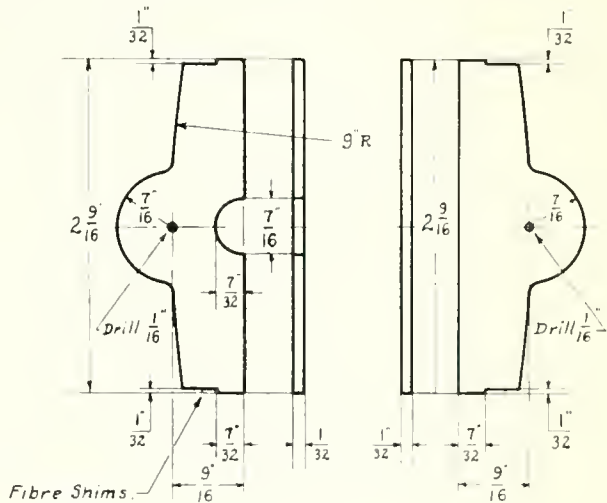
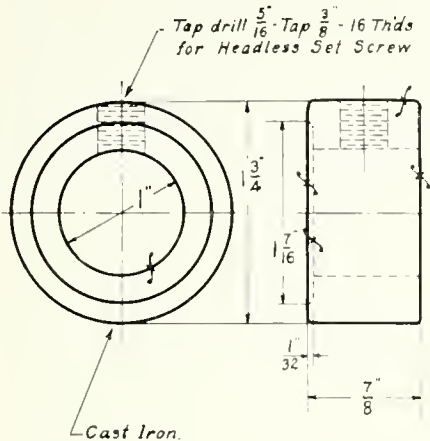

Job No. 16

DRAWING No 206 PART No Special

DETAILS OF BABBITTING JIG.

Scale ----- Work to figures.

SOUTH BEND LATHE WORKS

Job No. 17. Babbitting Jig.

Make a wood frame, as shown on opposite drawing Figure "X." Make it large enough so that the grinder frame can be easily placed inside.

Place the grinder head in the wooden frame and place babbitting shaft on the V ways. Shim up under grinder head with cardboard shims "BB," until the grinder bearings are concentric and parallel to the babbitting shaft. The top of the grinder bearings should be $1/64$ " below the center of the babbitting shaft. Now clamp the grinder head to the wood frame. Measure again to see that the bearing space of the grinder head is concentric and parallel with the shaft at both ends. Remove the shaft and place on it the four adjustable collars, setting each collar as close up to the bearings as possible. The dimensions are shown on drawing. Now with a piece of wood, plug up the four cap screw holes on grinder head. Place the four cardboard shims on top of bearings, so they will fit tight up against the shaft and inside both collars. Fasten each shim to the wood plug with a tack. With a piece of clay or putty, make a ringed dam "E," as shown, between the ends of bearings and collars. These dams are merely to prevent the babbitt from running out of the mould.

If the babbitt has a tendency to run out of the mould at any point, simply make a dam to prevent it. Make another dam "F" on the top of shim. (See Figure "X" also Plan View.) This dam laps

over on to the shaft. It is through this dam, through the hole "G" that the babbitt is poured to fill the bottom bearing.

Before pouring the mould see that the babbitt is hot, not red hot, but hot enough to singe or scorch a pine stick. Make a test by immersing the stick into the molten babbitt. There are a number of small anchor holes in the bearings of the mold, and if the metal is of the right temperature, it will flow readily and fill every crevice and anchor in the mould. If the babbitt does not fill the mould perfectly, the babbitt was not hot enough. In this case remove the babbitt and pour again. Do not attempt to pour both boxes with one ladle of babbitt as the metal cools quickly. Get a fresh supply in ladle for each box.

When both lower boxes have been babbitted, place new shims on all the bearings and attach the caps, screwing them down tight on the shims. Dam up between the ends of caps and collars. (See Figure "Y.") Now make a center dam "X" over this hole. When both caps are babbitted, remove the dam, placing a dog on the end of the babbitting shaft. Loosen the set screws in each collar and remove the shaft by a pulling, twisting movement. Now trim up the ends of each box.

For scraping boxes, see page 42.

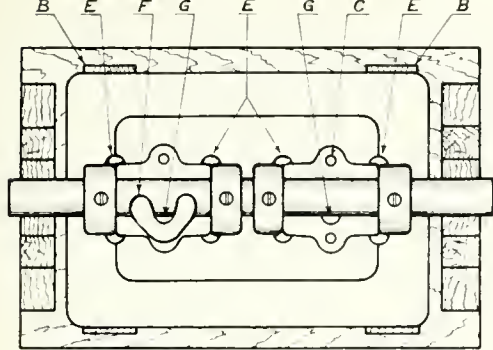

Plan View Fig. X

BABBITTING JIG

JOB No. 17

SOUTH BEND LATHE WORKS

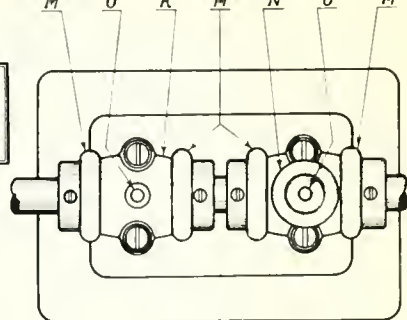

Plan View Fig. Y



Enlarged Section of "F"

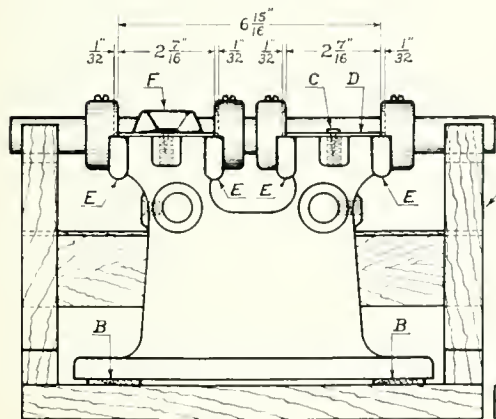
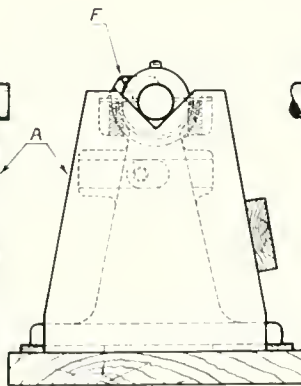

Fig. X



End View Fig. X

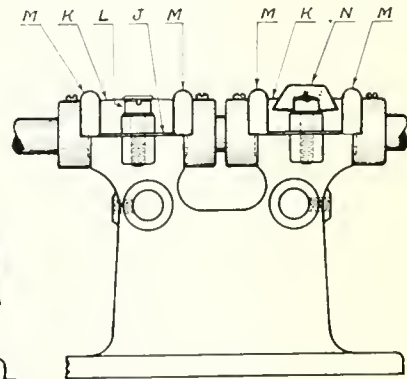

Fig. Y

Job No. 15. Part No. 30.

1. DRILLING HOLES FOR REST BRACKETS. Place the grinder head on two wooden cleats on top of saddle, one end of the cored hole on the head center and the other end on the tail center of lathe, thus lining up the cored hole, shim up under the grinder head, if necessary. Clamp grinder head to saddle if you wish. Now remove head center, and with a $47/64$ " drill in chuck (see drawing), start drilling. The drill should revolve slowly. With the right hand feeding by hand wheel of tail stock and the left hand operating the carriage wheel and the tail center still in cored hole, drill three-quarter way through the casting. Now replace the tail center with a drill pad, a piece of wood between drill pad and grinder, finish drilling the hole. Then size the hole with a $3/4$ " standard reamer. Machine the other hole in the same way.

The two small side holes, through which set screws pass to fasten the bracket, may be drilled by using the same cleats as for drilling the bracket holes.

It will not be necessary, in drilling these holes, to clamp the casting to the lathe carriage. Simply turn the grinder head around, place a $5/16$ " drill in the chuck, lay out the position of the hole in the end of boss on casting, and drill through into the

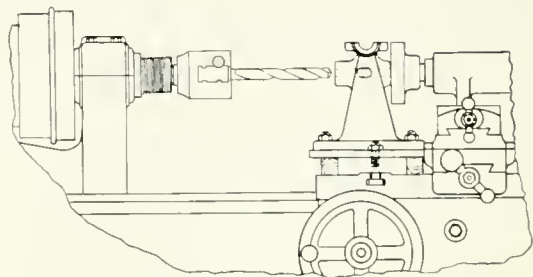

bracket hole, using the tail stock wheel to feed, holding the grinder casting with the left hand. When the hole is drilled, reverse position of the grinder casting, and drill a similar hole in the opposite end of casting.

Now tap the holes with a $3/8$ ", 16-thread, right hand U. S. Standard Tap, running through first with a taper tap, and finishing with a plug tap, using a hand tap wrench.

For castings and material in the rough, also supplies, etc., for building the 8-inch Bench Emery Grinder, see page 55.

Job No. 18. Part No. 15 and 16. Drawing No. 116.

To make a nut, secure a piece of cold drawn hexagon steel, $1\frac{1}{4}$ " across the flats. Place this material in a 3-Jaw Universal Geared Scroll Chuck, letting it extend far enough from the chuck so that two nuts can be made in one chucking.

Face the end of the material, locate the center, then with a $\frac{5}{8}$ " drill in the tail stock of chuck, bore a hole for a depth of two nuts. Then chamfer the end, and with a cutting-off tool, cut the nut the desired length. Repeat this operation on the second nut. Then place the nut back in the chuck, and with a $\frac{3}{4}$ ", 10-thread right hand U. S. Standard Taper Tap, held on tail centers by a monkey wrench, let the end of this tap enter the hole of the nut. (See drawing Figure "E," page 58.) Use plenty of oil on the tap. Then with the right hand feeding the tap, and the left hand pulling the belt, slowly feed the tap through the nut. Using the grinder spindle as an arbor on centers, face the nuts true on both ends.

Perhaps it would be much better to buy these nuts, rather than make them. The $\frac{3}{4}$ " right hand nut can be purchased from the hardware store, and perhaps the $\frac{3}{4}$ " left hand nut also. If not, we can furnish them, finished complete and hardened, at a nominal price.

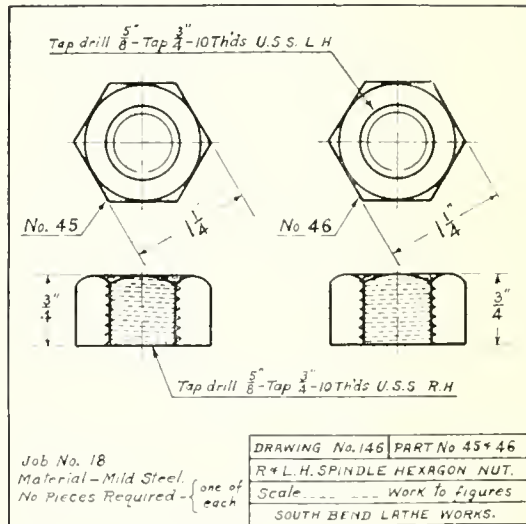

Job No. 27. Part No. 107. Drawing No. 207.

1. MATERIAL. A Lathe Mandrel is usually made of crucible or tool steel, so it may be hardened and tempered all over. However, for large mandrels, mild steel may be used instead of crucible, especially when an arbor is over $\frac{3}{4}$ " diameter, not excessive in length, and where it is not subjected to rough, heavy work. If carbon steel cannot be secured easily, we can use mild steel with good results.

Select a piece of mild steel, $7\frac{1}{8}$ " long. Center both ends, place on centers and face both ends. Take a roughing chip over the entire diameter. With a facing tool on an angle, recess both ends of the arbor to a depth of $\frac{1}{32}$ ". Let this recess extend about $\frac{1}{2}$ " in diameter. The object of this recess is that in driving a pulley or ring on to the arbor, or driving the arbor out of this pulley or ring, when the mallet comes in contact with the end of the arbor, it will not jamb or destroy the center hole.

Now reduce the diameter for a distance of $\frac{3}{4}$ " on each end, as shown. The object of this reduction is to have a suitable place to attach the driving dog. Then file a flat place on both shoulders for

the dog set screw to screw against. Now harden and temper the mandrel all over. If the material is crucible steel, for hardening and tempering follow instructions shown in section 62, page 46, of Lathe Book. If the arbor is made of mild steel, case harden both ends only as far as the shoulders. Follow instructions shown in section 64, page 46, of Lathe Book.

The mandrel has a slight taper, the small end of the fitting surface, finishing $.001$ " under the standard dimensions— $1\frac{1}{8}$ "; while the other end finishes $.002$ " above the standard dimensions. Therefore there is a difference of $.003$ " on the fitting diameter of the arbor, on a length of $5\frac{1}{2}$ ". This is to allow a piece to be driven off and on an arbor easily, and always from the same end.

Where arbors or lathe mandrels are made in quantity, the fitting diameter is finished by grinding; the mandrels are placed on centers in a special grinding machine, and revolve slowly, and are finished by a swiftly revolving emery wheel. A mild steel mandrel can, however, be finished very accurately by turning, and then filing and polishing with emery cloth. It requires care and accurate measurement with a micrometer caliper.

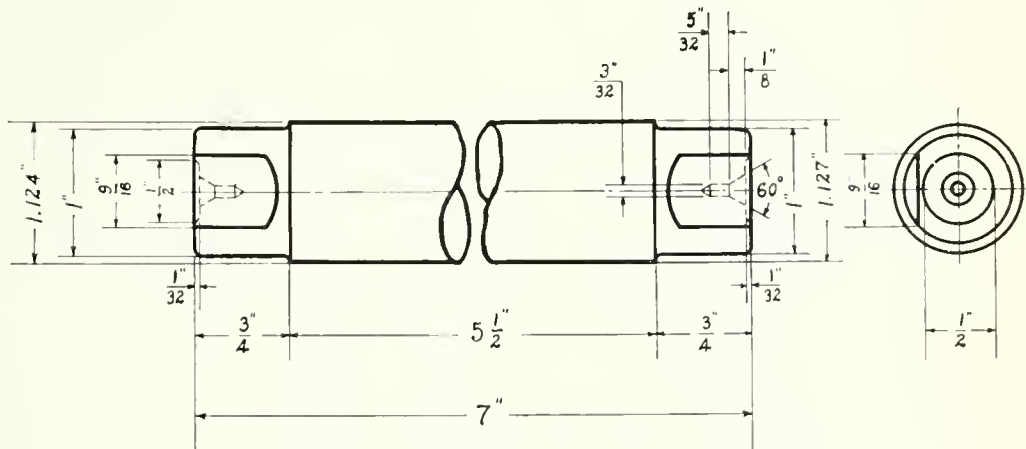

Job No. 27

Material - Carbon Steel.

No. Pieces Required - 1

DRAWING No. 207 PART No. 107

$\frac{1}{8}$ INCH MANDREL

Scale ----- Work to figures

SOUTH BEND LATHE WORKS.

Job No. 30. Part No. 109. Drawing No. 209.

1. MACHINING CHUCK PLATE. The drawing on the opposite page describes a chuck plate, required in fitting a lathe chuck to a lathe. This chuck plate is to be bored and threaded to fit the spindle nose of the 15" South Bend Lathe. The diameter "A" is to fit the recess in the back of chuck.

If there is only one lathe in the shop, and chuck is to be fitted to this lathe, then it would be necessary to swing the chuck plate on the large face plate. (See face plate job, page 58.) Before clamping chuck plate to face plate securely, bring the tail stock center up, and the tail center will tend to center the chuck plate. Now revolve the lathe slowly, and hold a piece of chalk to the hub of the chuck plate, until it runs true; then clamp securely to the face plate.

Take a chip on the face of the hub, and with a boring tool bore to the proper diameter, which is the bottom of the thread on spindle nose. Machine the recess to a diameter slightly in excess of the unthreaded diameter of spindle nose.

2. THREADING. Set the Threading Tool (as shown in Figure 16, page 30, of book "How to Run a Lathe"). Set the adjustable stop to depth of thread and proceed with the thread cutting, taking light chips. When you think the proper depth of thread has been reached, unscrew the face plate,

and without disturbing the chuck plate on the face plate, try the threaded part of the chuck plate on the spindle nose. If the chuck plate will not screw on spindle, take another chip and repeat this operation until the chuck plate screws snugly on the spindle nose.

Chuck plate being fitted, remove it from the face plate, screw it on to spindle nose firmly up against the shoulder. Put a couple drops of oil on threaded part of chuck plate, before screwing it on spindle nose. Then machine the diameter "A" to fit the recess of the chuck to be fitted. Use care in making this fit. Round the corners slightly with a file, on the face of diameter "A," where the bottom fits into the chuck recess.

When this fit is properly made, then place some red lead or chalk on the bottom of the entire recess of the chuck. Now press the chuck plate into recess. Make a center punch mark on the chuck plate and on the chuck, so that you will know the position to replace the chuck plate after holes are drilled. Rap chuck plate several times with a wooden mallet. Remove the chuck plate, and you will find indicated the proper position of the holes through which chuck screws pass. Drill these holes about $\frac{1}{32}$ " larger in diameter than the bolts or screws. Place the chuck plate back in recess of chuck, according to the center punch marks, attach your screws, and chuck is fitted ready for use.

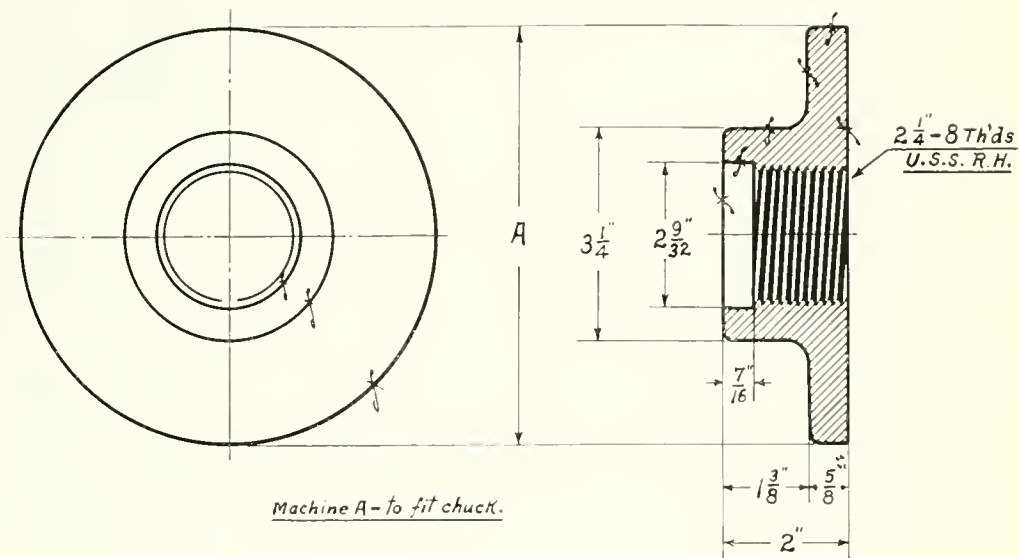

Job No. 30.
 Material - Cast Iron
 No. Pieces Required - 1

DRAWING No. 209	PART No. 109
CHUCK PLATE for 15" LATHE	
Scale ----- Work to figures.	
SOUTH BEND LATHE WORKS.	

Painting and Assembling the Grinder

The grinder should be painted after all machine work has been done. The castings have already been cleaned of all sand, sprues, etc., before machining.

Before applying a coat of paint, be sure that all trace of oil and grease has been removed from the grinder head. Then apply a coat of paint, good quality, any color will serve. This is what we call the priming coat.

After the priming coat is dry, apply a coat of iron filler.

This filler comes prepared in a form something similar to a soft, wet clay. The filler should be cut with turpentine until it resembles a paste as thick as can be applied easily with a brush. Paint the entire casting with a coat of this filler, with the exception of the machined surfaces. The coat will dry in from four to ten hours, depending upon the drying properties of the filler. When dry, rub down with coarse sandpaper in such a manner that you sand only the high spots. Then apply another coat of filler. When this is dry, sand again. If you wish the machine to look unusually nice, you should apply at least four coats of filler, and sand after each coat.

After the casting has been filled, apply a coat of sealer. This may be an oil-proof paint, or an enamel. Enamel makes the best sealer, because it is oil-proof, and it levels evenly. The color may be black, dark blue, or dark green. When the sealer or oil-proof coat of paint is dry, then assemble the machine.

For painting the bracket heads, the angle and T rests, follow the same instructions as given for painting the grinder head.

ASSEMBLING. After the painted parts are dry, assemble the machine. In assembling, place the end of the spindle having the left hand nut on the left hand end of the frame. The reason is, that when the emery wheels are revolving, the nuts should fasten in the direction of the rotation of the emery wheel, because the greater the speed, the greater the tendency to tighten the nuts, whereas, if the direction of the thread was reversed, the tendency would be to loosen the nuts.

When the machine is assembled apply a finishing coat of velvet black, preferably a dull velvet shade.

Safety Guards for Emery Wheels

The drawing herewith shows safety guards for guarding the emery wheels. These guards are made of malleable or cast iron. Malleable iron is recommended.

The guards are used in pairs, right and left. There is no difference in the design or the construction, except in the base. When making the pattern, disconnect the pattern at the base, using a right and left base, so that one large pattern will serve for the hoods.

There is no machine work done on these guards. All that is necessary is to sand and paint them.

INFORMATION ON EMERY WHEELS

- 1—SOUND wheels before MOUNTING to detect possible INJURY in TRANSIT.
- 2—Never FORCE wheels on spindles
- 3—Use RELIEVED flanges where possible.
- 4—Avoid UNNECESSARY tightening of flanges.
- 5—Keep rest CLOSE to wheel.
- 6—Keep wheels TRUE.
- 7—Keep BEARINGS adjusted.
- 8—Have Grinder on SOLID foundation.

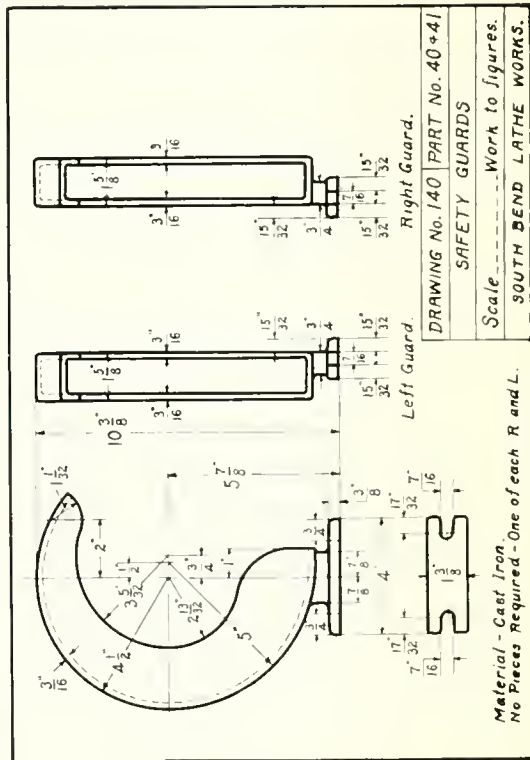

Manufacturing in the School Shop

Several of the larger manual training schools have already started to manufacture in a small way.

From our experience in manufacturing, we know that it is possible for the manual training schools to make something of commercial value in their shops, and the time will come when all manual training schools will require the students to work on something useful, something that can be sold, and a sum can be realized from the sale, at least sufficient to cover the cost of the material and supplies.

The Bench Grinder illustrated and described in this little text book, is a useful tool. It can be made in quantity in the school shop, and sold to other school shops. It can also be sold to the machinery trade.

A large machine shop equipment is not necessary for building the 8-inch Bench Grinder. The entire work can be done on a 15" South Bend Lathe. If the school equipment includes a drill press, milling machine and shaper, the work can be done to better advantage.

If the grinder countershaft is wanted, we can supply the castings and all parts in the rough, together with the necessary drawings and blue prints for the machining of these parts. A drawing of the countershaft may be seen on page 60.

We claim no patent on this grinder. Anyone who wishes to make the machine in part or whole, has our permission. We shall be glad to supply them with text books.

The work may be divided into four departments as follows: -

1. DRAWING ROOM. The students may make a complete set of drawings, using this text book as a guide.
2. PATTERN ROOM. A complete set of working patterns can be made from the above drawings.
3. FOUNDRY AND CORE ROOM. A complete set of cores and castings can be made up if the school has the necessary equipment.
4. MACHINE SHOP. This text book illustrates and describes in detail, the machining of the grinder.

Castings and Supplies for 8-Inch Bench Emery Grinder

For the accommodation of schools who wish to build the Tool Room Grinder, and are not in a position to make patterns or to secure the necessary castings, steel, etc., we shall be pleased to supply all the parts and material in the rough, as per the following list:

For explanation of part numbers and names, see drawing, page 3.

PART NO.	NAME
23	Machine Bolts
29	Grinder Head
30	Caps (2)
31	Spindle
32	Spindle Pulley
33	Rest Brackets, L. (2)
34	"T" Rest
35	"T" Rest Bracket
36	Angle Rest
37	Angle Rest Bracket
38	Inside Flanges (2)
39	Outside Flanges (2)
40-41	Safety Guard, R and L
43	Safety Guard Screws (1)
45-46	Hexagon Nuts, R. & L. H. for Spindle
47	Fillister Head Cap Screws for Bearings (1)

48	Headless Set Screw for Spindle Pulley
49	Sq. Head Set Screws for Rest Brackets (6)
50	Oil Cups (2)
51	Emery Wheels (2)

We can also furnish parts and supplies as follows:

Lathe Tools
 Lathe Dogs
 Babbitt Metal
 Babbitt Heater
 Babbitt Ladle
 Shims for Babbitting
 Babbitting Collars, Rough or Finished
 Babbitting Bar, Rough or Finished
 1 $\frac{1}{8}$ " Arbor, Rough or Finished
 $\frac{3}{4}$ " Arbor, Rough or Finished
 Semi-Machined Chuck Plate
 Chuck Arbor, Rough or Finished

A full set of working blue prints, 6 $\frac{1}{2}$ " x 9"

For prices of all material, castings, etc., in the rough, write for special circular mailed free on request. Address South Bend Lathe Works, Grinder Dept., 128 E. Madison Street, South Bend, Ind.

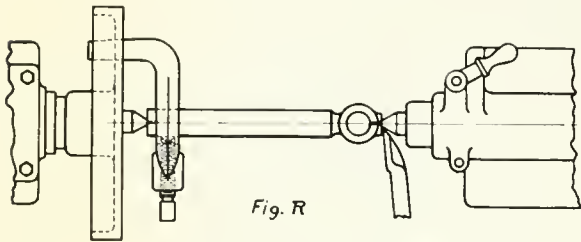

Fig. R
Driving by a Common Dog

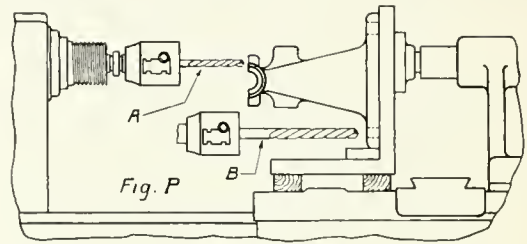

Fig. P
Drilling in the Lathe

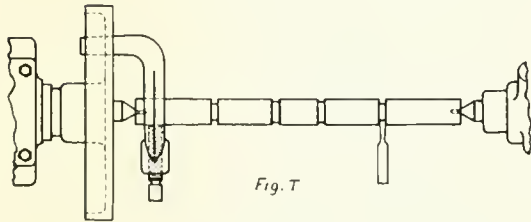

Fig. T
Cutting a Shoulder

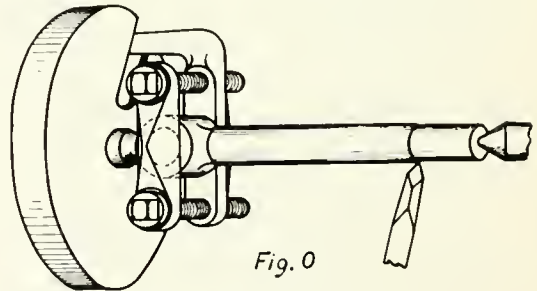

Fig. O
Driving by a Clamp Dog

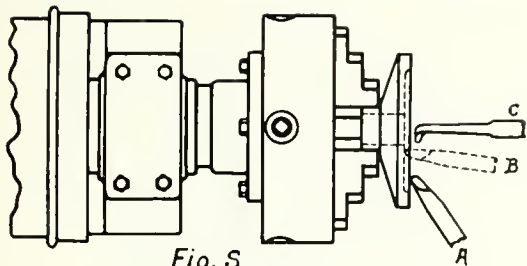

Fig. S
Chucking a Flange

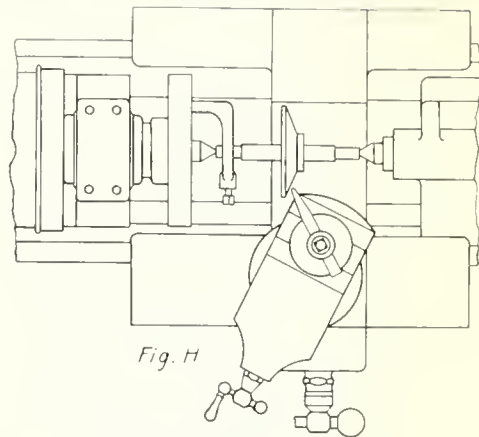

Fig. H
Compound Rest on an Angle

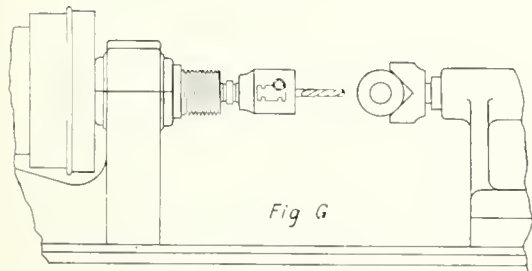

Fig. G
Drilling on the Diameter

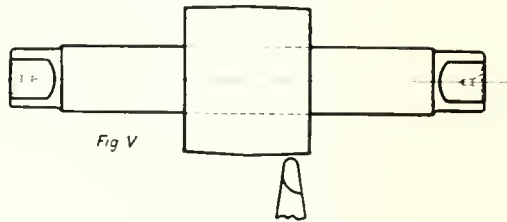

Fig. V
Pulley on Arbor

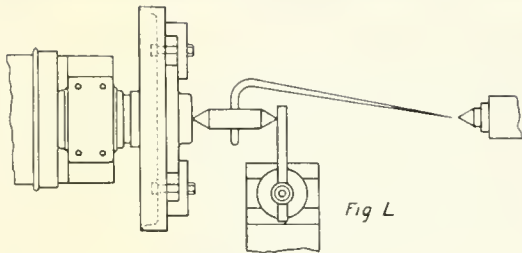

Fig L

Use of an Indicator

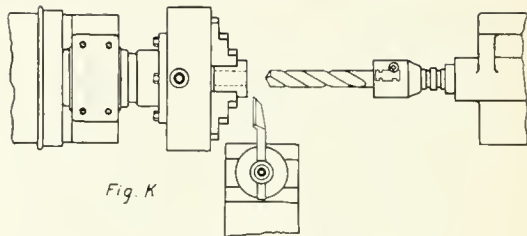
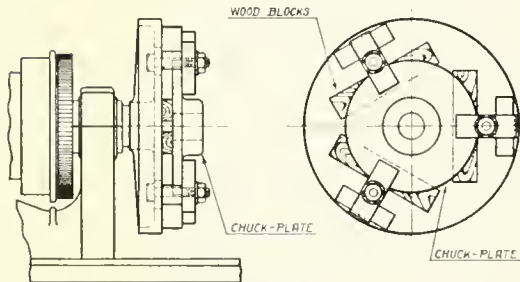

Fig K

Machining a Chuck Job



A Face Plate Job

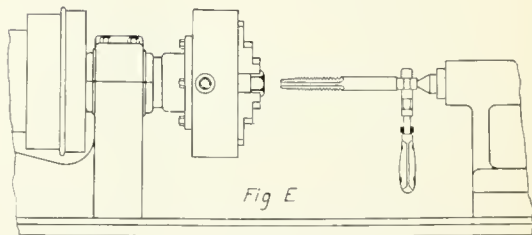
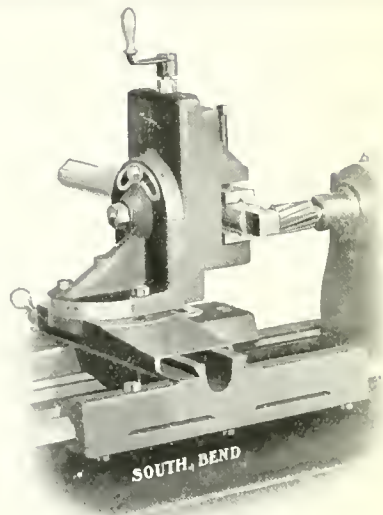
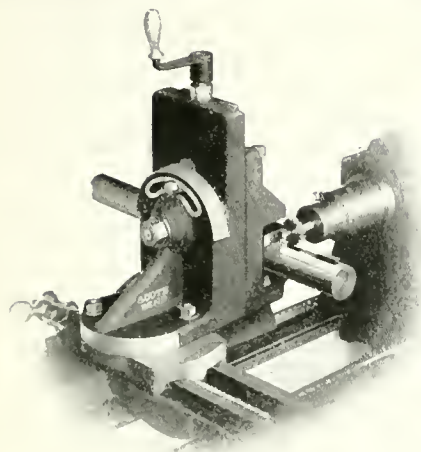

Fig E

Tapping in the Chuck



South Bend Milling and Key-Way Cutting Attachment for Lathes

The above two half-tones show our improved Milling and Key-Way Cutting Attachment for lathes. This attachment is very practical on a lathe in the shop where there is no milling machine or shaper.

The attachment is designed for South Bend lathes, but it can also be fitted by a mechanic to lathes of other makes that are equipped with compound rest. This Milling and Key-Way Cutting Attachment is fully described in South Bend Lathe Catalog. Write for free catalog.

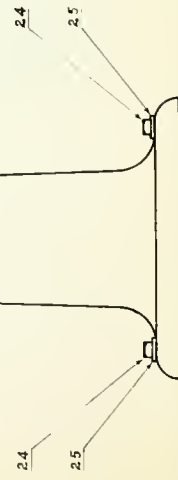
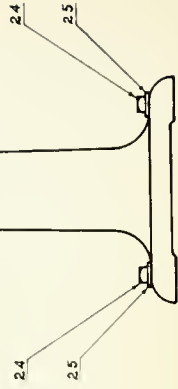
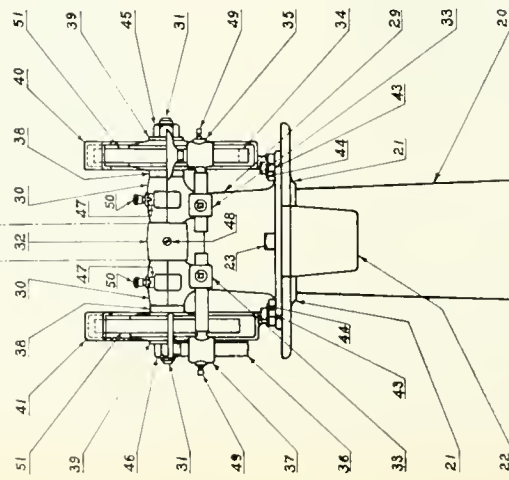
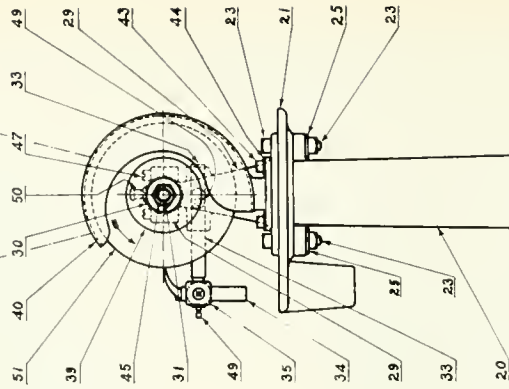
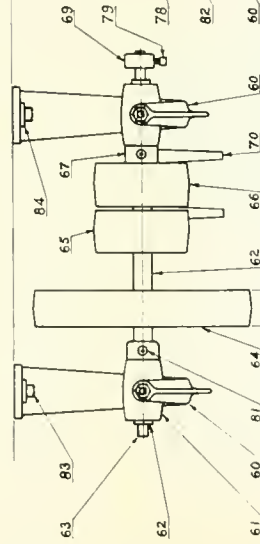
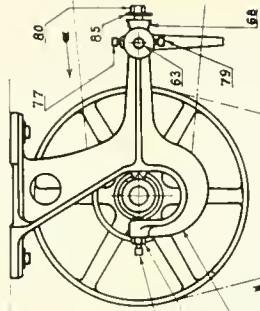

Column or Floor Grinder

The Column Grinder would make an excellent job for some of the larger engineering and manual training schools.

The assembled drawing on the opposite page shows the 8-inch Tool Room Bench Grinder fitted with Column, Pan, Water Pot and Counter-shaft complete. This is what we call a Column or Floor Grinder, because it can be fastened to the floor.

We have numbered each part, and can furnish the castings and parts of the entire machine, in the rough; complete drawings or blue prints.

The drawing shows the arrangement of the countershaft for either the Bench or the Column Grinder.

The distance between the spindle and center of countershaft should not be less than 5 feet. 7 or 8 feet would be better. The side illustration shows the center of countershaft directly over the center of spindle. This is not necessary. In fact, better results are obtained when the center of countershaft is at least 12-inches farther to the rear than the center of grinder spindle.

If the countershaft is used to drive grinder, the countershaft should be driven from a line shaft; the countershaft in turn driving the grinder spindle. An excellent arrangement of this kind is illustrated and described on pages 2 and 3 of Lathe Book, ("How to Run a Lathe").

A $\frac{1}{4}$ -H. P. Motor has ample power for driving either the Bench or Column Grinder through the countershaft.

If, however, the motor is to drive a line shaft, and the grinder countershaft is to be driven from this line shaft, we would recommend a $\frac{1}{2}$ -H. P. motor. If there are a couple of small machines to be driven from the line shaft in addition to the grinder, we would recommend a 1-H. P. motor.

Weight of Bench Grinder, machined.....	50 lbs.
Weight of Countershaft, machined.....	50 lbs.
Weight of Column, Pan and Water Pot, machined.....	112 lbs.
Total Weight.....	212 lbs.

For the accommodation of schools who wish to build the Tool Room Floor Grinder complete, we shall be pleased to furnish castings in the rough and tools and supplies for the Bench Grinder, Countershaft, Column, Pan and Water Pot. The rough castings and material, boxed ready for shipment, will weigh approximately from ten to twenty per cent. more than the finished grinder.

For prices of all material, castings, etc., in the rough, write for special circular mailed free on request. Address South Bend Lathe Works, Grinder Dept., 428 E. Madison St., South Bend, Ind.

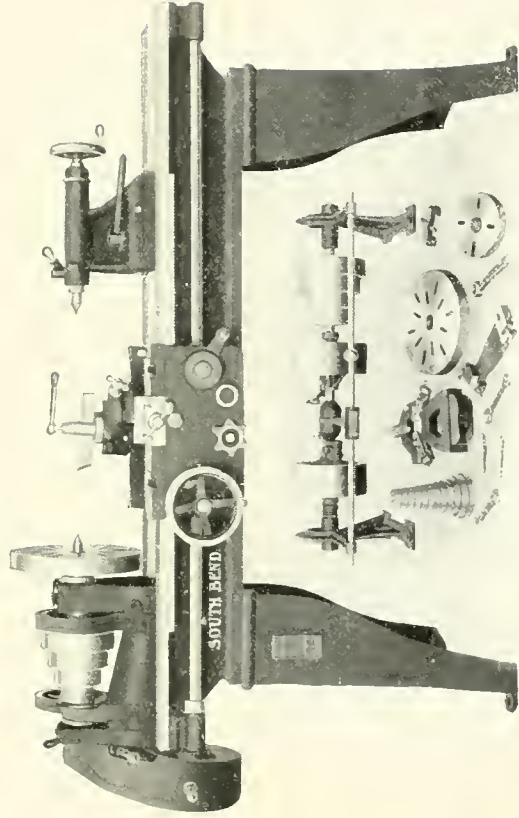

Regular equipment, as illustrated under lathe, is included in price.

The No. 37—15"x6" Lathe

SOUTH BEND SCREW CUTTING ENGINE LATHE

Fitted with Automatic Longitudinal Feed, Automatic Cross Feed
and Compound Rest

The No. 37, 15" x 6" South Bend Lathe, illustrated above, is the most practical size, and the one which we recommend for the school shop.

The South Bend Lathe has been on the market for over ten years. There are now over 12,000 of these lathes in use, principally in industrial and manufacturing lines.

Of late years, the lathe has also become popular with the school trade. The machine that is most practical for the manufacturer in the commercial machine shop, is the one that will also serve to the best interest in the school shop.

South Bend Lathes will be shipped to any school on approval, and if not satisfactory, may be returned. We pay freight both ways.

CATALOG. Free interesting catalog, describing the entire line of South Bend Lathes, showing prices of all lathes and attachments. Catalog mailed free to any address.

SOUTH BEND LATHES ARE MADE IN THE FOLLOWING SIZES:

No. of Lathe	Swing Over Bed	Length of Bed	Distance Between Centers	Hole in Spindle	Approx. Weight Cast	Code Word
No. 34 13-INCH SOUTH BEND LATHE						
34	13 $\frac{1}{4}$ in.	5 ft.	33 in.	3 $\frac{1}{4}$ in.	1000	Haseno
34	13 $\frac{1}{4}$ in.	6 ft.	45 in.	3 $\frac{1}{4}$ in.	1060	Hisorito
34	13 $\frac{1}{4}$ in.	7 ft.	57 in.	3 $\frac{1}{4}$ in.	1140	Horteno
34	13 $\frac{1}{4}$ in.	8 ft.	69 in.	3 $\frac{1}{4}$ in.	1170	Homeo
No. 36 14-INCH SOUTH BEND LATHE						
36	14 $\frac{1}{4}$ in.	5 ft.	30 in.	1 $\frac{1}{2}$ in.	1100	Itaio
36	14 $\frac{1}{4}$ in.	6 ft.	42 in.	1 $\frac{1}{2}$ in.	1175	Irono
36	14 $\frac{1}{4}$ in.	7 ft.	54 in.	1 $\frac{1}{2}$ in.	1250	Issueo
36	14 $\frac{1}{4}$ in.	8 ft.	65 in.	1 $\frac{1}{2}$ in.	1325	Ivonyo
36	14 $\frac{1}{4}$ in.	10 ft.	90 in.	1 $\frac{1}{2}$ in.	1450	Isleto
No. 37 15-INCH SOUTH BEND LATHE						
37	15 $\frac{1}{4}$ in.	5 ft.	28 in.	1 $\frac{1}{8}$ in.	1375	Jasso
37	15 $\frac{1}{4}$ in.	6 ft.	40 in.	1 $\frac{1}{8}$ in.	1455	Jadino
37	15 $\frac{1}{4}$ in.	7 ft.	52 in.	1 $\frac{1}{8}$ in.	1475	Jagilo
37	15 $\frac{1}{4}$ in.	8 ft.	64 in.	1 $\frac{1}{8}$ in.	1500	Jilono
37	15 $\frac{1}{4}$ in.	10 ft.	88 in.	1 $\frac{1}{8}$ in.	1600	Jokero
No. 40 16-INCH SOUTH BEND LATHE						
40	16 $\frac{1}{4}$ in.	6 ft.	36 in.	1 $\frac{1}{8}$ in.	1700	Juddo
40	16 $\frac{1}{4}$ in.	7 ft.	48 in.	1 $\frac{1}{8}$ in.	1750	Judrano
40	16 $\frac{1}{4}$ in.	8 ft.	60 in.	1 $\frac{1}{8}$ in.	1825	Jucyo
40	16 $\frac{1}{4}$ in.	10 ft.	84 in.	1 $\frac{1}{8}$ in.	2025	Jularo
40	16 $\frac{1}{4}$ in.	12 ft.	108 in.	1 $\frac{1}{8}$ in.	2230	Junjero
No. 44 18-INCH SOUTH BEND LATHE						
44	18 $\frac{1}{4}$ in.	6 ft.	35 in.	1 $\frac{1}{8}$ in.	1800	Kameo
44	18 $\frac{1}{4}$ in.	7 ft.	45 in.	1 $\frac{1}{8}$ in.	1875	Karsto
44	18 $\frac{1}{4}$ in.	8 ft.	57 in.	1 $\frac{1}{8}$ in.	2000	Kello
44	18 $\frac{1}{4}$ in.	10 ft.	81 in.	1 $\frac{1}{8}$ in.	2200	Kerro
44	18 $\frac{1}{4}$ in.	12 ft.	105 in.	1 $\frac{1}{8}$ in.	2300	Kosso

We also make lathes 21-inch and 24-inch swing.

University of California
SOUTHERN REGIONAL LIBRARY FACILITY
405 Hilgard Avenue, Los Angeles, CA 90024-1388
Return this material to the library
from which it was borrowed.

OCT 10 1996

AUG 23 2000

UNIVERSITY OF CALIFORNIA

epted

contains
are the

ings, and
likely to

Making and fitting of piston rings.
Truing a valve stem.
Making of ball race and cone.
Drawings and description of standard tapers.
Hardening, tempering and annealing steel.
Case hardening, etc., etc.



B 000 003 235 9

FIRST YEAR LATHE WORK

PRICE 10 CENTS

Coin or stamps accepted.
Postpaid to any address.



We have made the price of this little book as low as possible, so that each student taking shop work can afford to have a copy.

A Partial List of Schools that are Using South Bend Lathes

- | | | |
|----------------------------------------------------|------------------------------------------------------------|--------------------------------------------------------------------|
| U. S. Military Academy, West Point | Kansas City Board of Education | Technical High School, Atlanta, Ga. |
| Chicago Board of Education | University of Southern Minnesota | University of Missouri, Columbia, Mo. |
| New York City Board of Education | New Kensington Borough High School,
New Kensington, Pa. | Miss. Agricultural & Mech. College,
Agricultural College, Miss. |
| University of Chicago | Rice Institute, Houston, Texas | University of Oregon, Eugene, Ore. |
| Lawrence High School, Falmouth,
Mass. | Harvard University | Mass. Agricultural College, Amherst,
Mass. |
| Western State Normal School,
Kalamazoo, Mich. | Leland Stanford University, Palo Alto,
Calif. | Johns Hopkins Medical School,
Baltimore, Md. |
| Valley City, N. D., Board of Education | W. Va. Industrial School for Boys,
Charleston, W. Va. | Quincy Industrial School, Quincy,
Mass. |
| University of Illinois, Champaign, Ill. | Miles Standish School, Boston, Mass. | University of Texas, Austin, Texas |
| Tacoma Public High School, Tacoma,
Wash. | Parkman School, Boston, Mass. | University of Illinois, Urbana, Ill. |
| Detroit, Mich., Board of Education | Arthur Hill Trade School, Saginaw,
Mich. | Akron, Ohio, Board of Education |
| University of City of Cincinnati | South Bend High School, South Bend,
Ind. | Fort Apache Indian School, Holbrook,
Ariz. |
| Boys High School, Frederick, Md. | Jefferson School, Stockton, Calif. | Somerset, Ky., Board of Education |
| U. S. School of Field Artillery | Marinette, Wis., Board of Education | Huntington, W. Va., Board of Education |
| Illinois School for Deaf, Jacksonville,
Ill. | University of Michigan, Ann Arbor,
Mich. | Clark University, Worcester, Mass. |
| Blue Island, Ill., Board of Education | Delaware College, Newark, Del. | Sterling Township High School,
Sterling, Ill. |
| Virginia Polytechnic Institute,
Blacksburg, Va. | School District No. 27, Douglas, Ariz. | Fort Wayne Vocational School,
Fort Wayne, Ind. |
| University of Utah, Salt Lake City,
Utah | Janesville High School, Janesville,
Wis. | University of Porto Rico |
| Dartmouth Medical School, Norwich,
Vermont | Mann Vocational School, Lowell, Mass. | Ridgway-Bore, School Dist., Ridgway,
Pa. |
| Green Bay, Wis., Board of Education | Van Wert, Ohio, Board of Education | Bliss Electric School, Washington,
D. C. |
| Valparaiso University, Valparaiso, Ind. | State Normal School, Oshkosh, Wis. | Centennial High School, Pueblo, Colo. |
| Central High School, Guelph, Canada | Manitowoc, Wis., Board of Industrial
Education | Oswego Normal School, Oswego, N. Y. |
| Portland, Ore., Board of Education | Coronado High School, Coronado,
Calif. | Queen Anne High School, Seattle, Wash. |
| Portland, Maine Board of Education | Galesburg High School, Galesburg, Ill. | Ballard High School, Seattle, Wash. |
| Waverly, N. Y., Board of Education | Illinois Wesleyan University,
Bloomington, Ill. | West Seattle High School, Seattle,
Wash. |
| University of Colorado, Boulder, Col. | | |