

**ARMY TECHNICAL MANUAL TM5-6115-465-34**  
**NAVY PUBLICATION NAVFAC P-8-625-34**  
**AIR FORCE TECHNICAL ORDER TO-35C2-3-446-2**  
**MARINE CORPS TECHNICAL MANUAL TM-06858B/06859D-34**

---

**TECHNICAL MANUAL**

**INTERMEDIATE (FIELD) (DIRECT AND GENERAL SUPPORT)**

**AND DEPOT LEVEL MAINTENANCE MANUAL**

**GENERATOR SET, DIESEL ENGINE DRIVEN, TACTICAL SKID MTD. 30 KW,  
3 PHASE, 4 WIRE, 120/208 AND 240/416 VOLTS**

<u>DOD MODEL</u>	<u>CLASS</u>	<u>HERTZ</u>	<u>FSN</u>
MEP-005A	UTILITY	50/60	6115-118-1240
MEP-104A	PRECISE	50/60	6115-118-1247
MEP-114A	PRECISE	50/60	6115-118-1248

**INCLUDING OPTIONAL KITS**

<u>DOD MODEL</u>	<u>NOMENCLATURE:</u>	<u>FSN</u>
MEP-005AWF	WINTERIZATION KIT, FUEL BURNING	6115-463-9083
MEP-005AWE	WINTERIZATION KIT, ELECTRIC	6115-463-9085
MEP-005ALM	LOAD BANK KIT	6115-463-9088
MEP-005AWM	WHEEL MOUNTING KIT	6115-463-9094

---

**PUBLISHED UNDER THE AUTHORITY OF THE DEPARTMENTS OF THE ARMY, AIR FORCE, AND NAVY  
(INCLUDING U.S. MARINE CORPS)**

**JANUARY 1975**

This copy is a reprint which includes current pages from Changes 1 through 9.



CHANGE

HEADQUARTERS  
DEPARTMENTS OF THE ARMY, NAVY AND AIR FORCE  
AND HEADQUARTERS U.S. MARINE CORPS  
WASHINGTON, D.C., 28 FEBRUARY 1994

No. 12

Intermediate (Field) (Direct and General Support)  
and Depot Level Maintenance Manual

GENERATOR SET, DIESEL ENGINE DRIVEN, TACTICAL SKID MTD. 30 KW,  
3 PHASE, 4 WIRE, 120/208 AND 240/416 VOLTS

<u>DOD MODEL</u>	<u>CLASS</u>	<u>HERTZ</u>	<u>NSN</u>
MEP-005A	UTILITY	50/60	6115-00-118-1240
MEP-104A	PRECISE	50/60	6115-00-118-1247
MEP-114A	PRECISE	50/60	6115-00-118-1248

INCLUDING OPTIONAL KITS

<u>DOD MODEL</u>	<u>NOMENCLATURE</u>	<u>NSN</u>
MEP-005AWF	WINTERIZATION KIT, FUEL BURNING	6115-00-463-9083
MEP-005AWE	WINTERIZATION KIT, ELECTRIC	6115-00-463-9085
MEP-005ALM	LOAD BANK KIT	6115-00-463-9088
MEP-005AWM	WHEEL MOUNTING KIT	6115-00-463-9094
MEP-005MS	ACOUSTIC SUPPRESSION KIT (ARMY ONLY)	6115-01-234-6545

DISTRIBUTION STATEMENT A: Approved for public release; distribution is unlimited.

TM 5-6115-465-34/NAVFAC P-8-625-34/TO 35C2-3-446-2/TM 06858B/06859D-34, 31 January 1975, is changed as follows:

1. Cover is changed from FSN to NSN.
2. Remove and insert pages as indicated below. New or changed text material is indicated by a vertical bar in the margin. An illustration change is indicated by a miniature pointing hand.

Remove pages

Insert pages

1-7 through 1-10

1-7 through 1-10

3. Retain this sheet in front of manual for reference purposes.

TM 5-6115-465-34  
NAVFAC P-6-625-34  
TO 35C2-3-446-2  
TM 06858B/06859D-34  
C 12

By Order of the Secretaries of the Army, Air Force, and Navy (Including the Marine Corps):

Official:

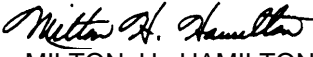
  
MILTON H. HAMILTON  
*Administrative Assistant to the  
Secretary of the Army*  
06517

GORDON R. SULLIVAN  
*General, United States Army  
Chief of Staff*

**MERRILL A. McPEAK**  
*General, USAF  
Chief of Staff*

Official:

**RONALD W. YATES**  
*General, USAF  
Commander, Air Force Materiel Command*

**JACK E. BUFFINGTON**  
*Rear Admiral, CEC, US Navy  
Commander  
Navy Facilities Engineering  
Command*

**D. R. BLOOMER**  
*Colonel, USMC  
Director Program Support  
Marine Corps Systems Command*

Distribution:

To be distributed in accordance with DA Form 12-25-E, block no. 0652, requirements for  
TM 5-6115-465-34.

CHANGE

HEADQUARTERS  
DEPARTMENTS OF THE ARMY, NAVY AND AIR FORCE  
AND HEADQUARTERS U.S. MARINE CORPS  
WASHINGTON D.C., 30 NOVEMBER 1992

NO. 11

Intermediate (Field) (Direct and General Support)  
And Depot Level Maintenance Manual

**GENERATOR SET, DIESEL ENGINE DRIVEN, TACTICAL SKID MTD.  
30 kW, 3 PHASE, 4 WIRE, 120/208 AND 240/416 VOLTS**

<u>DOD MODEL</u>	<u>CLASS</u>	<u>HERTZ</u>	<u>FSN</u>
MEP-005A	UTILITY	50/60	6115-118-1240
MEP-104A	PRECISE	50/60	6115-118-1247
MEP-114A	PRECISE	50/60	6115-118-1248

**INCLUDING OPTIONAL KITS**

<u>DOD MODEL</u>	<u>NOMENCLATURE</u>	<u>FSN</u>
MEP-005AWF	WINTERIZATION KIT, FUEL BURNING	6115-463-9083
MEP-005AWE	WINTERIZATION KIT, ELECTRIC	6115-463-9085
MEP-005ALM	LOAD BANK KIT	6115-463-9088
MEP-005AWM	WHEEL MOUNTING KIT	6115-463-9094
MEP-005AAS	ACOUSTIC SUPPRESSION KIT (ARMY ONLY)	6115-01-234-6545

Approved for public release; Distribution is unlimited

TM 5-6115-465-34/NAVFAC P-8-625-34/TO35C2-3-446-2/TM 06858B/06859D-34, 31 January 1975 is changed as follows:

1. Remove and insert pages as indicated below. New or changed text material is indicated by a vertical bar in the margin. An illustration change is indicated by a miniature pointing hand.

Remove pages

Insert pages

8-43/(8-44 blank)

8-43/(8-44 blank)

2. Retain this sheet in front of manual for reference purposes.

TM5-6115-465-34  
NAVFAC P-8-625-34  
TO 35C2-3-446-2  
TM 06858B/06859D-34  
C 11

By Order of the Secretaries of the Army, Air Force, and Navy (Including the Marine Corps):

Official:

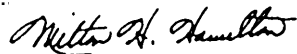

MILTON H. HAMILTON  
*Administrative Assistant to the  
Secretary of the Army*

02982

GORDON R. SULLIVAN  
*General, United States Army  
Chief of Staff*

**MERRILL A. McPEAK**  
*General, USAF  
Chief of Staff*

Official:

RONALD W. YATES  
*General, United States Air Force  
Commander, Air Force Materiel Command*

**DAVID E. BOTTORFF**  
*Rear Admiral, CEC, US Navy  
Commander  
Navy Facilities Engineering Command*

**RONALD D. ELLIOTT**  
*Executive Director  
Marine Corps Systems Command*

DISTRIBUTION:

To be distributed in accordance with DA Form 12-25-E, block no. 0652, requirements for TM 5-6115-465-34.

CHANGE

HEADQUARTERS,  
DEPARTMENTS OF THE ARMY, NAVY AND AIR FORCE  
AND HEADQUARTERS U.S. MARINE CORPS  
WASHINGTON, D.C., 30 September 1991

NO. 10

Intermediate (Field) (Direct and General Support)  
And Depot Level Maintenance Manual

GENERATOR SET, DIESEL ENGINE DRIVEN, TACTICAL SKID MTD., 30 KW,  
3 PHASE, 4 WIRE, 120/208 AND 240/416 VOLTS

<u>DOD MODEL</u>	<u>CLASS</u>	<u>HERTZ</u>	<u>FSN</u>
MEP-005A	UTILITY	50/60	6115-118-1240
MEP-104A	PRECISE	50/60	6115-118-1247
MEP-114A	PRECISE	50/60	6115-118-1248

INCLUDING OPTIONAL KITS

<u>DOD MODEL</u>	<u>NOMENCLATURE</u>	<u>FSN</u>
MEP-005AWF	WINTERIZATION KIT, FUEL BURNING	6115463-9083
MEP-005AWE	WINTERIZATION KIT, ELECTRIC	6115463-9085
MEP-005ALM	LOAD BANK KIT	6115-463-9088
MEP-005AWM	WHEEL MOUNTING KIT	6115-463-9094
MEP-005AAS	ACOUSTIC SUPPRESSION KIT (ARMY ONLY)	6115-01-234-6545

Approved for public release; distribution is unlimited

TM 5-6115-465-34/NAVFAC P-8-625-34/TO 35C2-3-446-2/TM 06858B/06859D-34, 31 January 1975, is changed as follows:

1. Remove and insert pages as indicated below. New or changed text material is indicated by a vertical bar in the margin. An illustration change is indicated by a miniature pointing hand.

Remove pages

Insert pages

3-9 and 3-10

3-9 and 3-10

2. Retain this sheet in front of manual for reference purposes.

TM 5-6115-465-34  
NAVFAC P-8-625-34  
TO 35C2-3-446-2  
TM 06858B/06859D-34  
C 10

By Order of the Secretaries of the Army , Air Force, and Navy (Including the Marine Corps):

**CARL E. VUONO**  
*General, United States Army*  
*Chief of Staff*

Official:

**PATRICIA P. HICKERSON**  
*Brigadier General, United States Army*  
*The Adjutant General*

**MERRILL A. McPEAK**  
*General USAF*  
*Chief of Staff*

Official:

**CHARLES C. McDONALD**  
*General, USAF*  
*Commander, Air Force Logistics Command*

**DAVID E. BOTTORFF**  
*Rear Admiral, CEC, US Navy*  
*Commander*  
*Navy Facilities Engineering Command*

**H.E. REESE**  
*Deputy for Support*  
*Marine Corps Research, Development and*  
*Acquisition Command*

DISTRIBUTION:

To be distributed in accordance with DA Form 12-25E, (qty rqr block no. 0852)



CHANGE

HEADQUARTERS,  
 DEPARTMENTS OF THE ARMY, NAVY AND AIR FORCE  
 AND HEADQUARTERS U.S. MARINE CORPS  
 WASHINGTON, D.C., 18 January 1991

NO. 9

Intermediate (Field) (Direct and General Support)  
 And Depot Level Maintenance Manual

**GENERATOR SET, DIESEL ENGINE DRIVEN, TACTICAL SKID MTD. 30KW,  
 3 PHASE, 4 WIRE, 120/208 AND 240/416 VOLTS**

<u>DOD MODEL</u>	<u>CLASS</u>	<u>HERTZ</u>	<u>FSN</u>
MEP-005A	UTILITY	50/60	6115-118-1240
MEP-104A	PRECISE	50/60	6115-118-1247
MEP-114A	PRECISE	50/60	6115-118-1248

INCLUDING OPTIONAL KITS

<u>DOD MODEL</u>	<u>NOMENCLATURE</u>	<u>FSN</u>
MEP-005AWF	WINTERIZATION KIT, FUEL BURNING	6115-463-9083
MEP-005AWE	WINTERIZATION KIT, ELECTRIC	6115-463-9085
MEP-005ALM	LOAD BANK KIT	6115-463-9088
MEP-005AWM	WHEEL MOUNTING KIT	6115-463-9094
MEP-005AAS	ACOUSTIC SUPPRESSION KIT (ARMY ONLY)	6115-01-234-6545

Approved for public release; distribution is unlimited

TM5-6115-465-34, NAVFAC P-8-625-34, TO 35C2-3-446-2, TM 06858B/06859D-34, 31 January 1975  
 is changed as follows:

1. Remove and insert pages as indicated below. New or changed text material is indicated by a vertical bar in the margin. An illustration change is indicated by a miniature pointing hand.

Remove pages	Insert pages
Warning/A	a/(b blank)
- - -	A/(B blank)
ix and x	ix and x
3-21 and 3-22	3-21 and 3-22
- - -	3-22.1/(3-22.2 blank)
3-23 and 3-24	3-23 and 3-24
3-69 and 3-70	3-69 and 3-70
4-13 and 4-14	4-13 and 4-14
4-19 and 4-20	4-19 and 4-20
5-27 and 5-28	5-27 and 5-28

Remove pages (con't)

5-28.1/(5-28.2 blank)  
5-59 and 5-60  
- - -  
5-69 and 5-70  
8-39 through 8-44  
8-47 and 8-48

Insert pages (con't)

5-28.1 and 5-28.2  
5-59 and 5-60  
5-60.1/(5-60.2 blank)  
5-69 and 5-70  
8-39 though 8-43/(8-44 blank)  
8-47 and 8-48

2. Retain this sheet in front of manual for reference purposes.

By Order of the Secretaries of the Army, Air Force, and Navy (Including the Marine Corps):

**CARL E. VUONO**

*General, United States Army  
Chief of Staff*

Official:

**THOMAS F. SIKORA**

*Brigadier General, United States Army  
The Adjutant General*

**MERRILL A. McPEAK**

*General USAF  
Chief of Staff*

Official:

**CHARLES C. MCDONALD**

*General, USAF  
Commander, Air Force Logistics Command*

**DAVID E. BUTTORFF**

*Rear Admiral, CEC, US Navy  
Commander  
Navy Facilities Engineering Command*

**H.E. REESE**

*Executive Director  
Marine Corps Research, Development and  
Acquisition Command*

DISTRIBUTION:

To be distributed in accordance with DA Form 12-25E, (qty rqr block no. 0852)

Army Technical Manual  
 Navy Publication  
 Air Force Technical Order  
 Marine Corps Technical Manual

TM 5-6115-465-34  
 NAVFAC P-8-625-34  
 TO 35C2-3-446-2  
 TM 06858B/06859D-34  
 C 8

CHANGE }  
 NO. 8 }

DEPARTMENTS OF THE ARMY, THE NAVY  
 AND THE AIR FORCE  
 ( INCLUDING THE US MARINE CORPS)  
 WASHINGTON, D.C., 19 August 1988

Intermediate (Field) (Direct and General Support)  
 And Depot Level Maintenance Manual

GENERAL SET, DIESEL ENGINE DRIVEN, TACTICAL SKID MTD. 30 KW,  
 3 PHASE, 4 WIRE, 120/208 AND 240/416 VOLTS

<u>DOD MODEL</u>	<u>CLASS</u>	<u>HERTZ</u>	<u>FSN</u>
MEP-005A	UTILITY	50/60	6115-118-1240
MEP-104A	PRECISE	50/60	6115-118-1247
MEP-114A	PRECISE	50/60	6115-118-1248

INCLUDING OPTIONAL KITS

<u>DOD MODEL</u>	<u>NOMENCLATURE</u>	<u>FSN</u>
MEP-005AWF	WINTERIZATION KIT, FUEL BURNING	6115-463-9083
MEP-005AWE	WINTERIZATION KIT, ELECTRIC	6115-463-9085
MEP-005ALM	LOAD BANK KIT	6115-463-9088
MEP-005AWM	WHEEL MOUNTING KIT	6115-463-9094
MEP-005AAS	ACOUSTIC SUPPRESSION KIT (ARMY ONLY)	6115-01-234-6545

TM 5-6115-465-34/NAVFAC P-8-625-34/TO 35C2-3-446-2/TM 06858B/06859D-34, 31  
 January 1975, is changed as follows:

1. Title is changed as shown above.

2. Remove and insert pages as indicated below. New or changed text material  
 is indicated by a vertical bar in the margin. An illustration change is indicated  
 by a miniature pointing hand.

Remove pages	Insert pages
v and vi	v and vi
---	xi and xii
1-1 and 1-2	1-1 and 1-2
1-7 and 1-8	1-7 and 1-8
2-1 and 2-2	2-1 and 2-2
2-2.1 and 2-2.2	2-2.1 and 2-2.2
---	2-2.3/2-2.4
3-9 and 3-10	3-9 and 3-10
3-61 through 3-64	3-61 through 3-64
4-40.3 and 4-40.4	4-40.3 and 4-40.4
5-13 and 5-14	5-13 and 5-14
---	8-39 through 8-48
Index 1 and Index 2	Index 1 and Index 2

3. Retain this sheet in front of manual for reference purposes.

TM 5-6115-465-34  
NAVFAC P-8-625-34  
TO 35C2-3-446-2  
TM 06858B.06859D-34

**By Order of the Secretaries of the Army, the Navy, and the Air Force:**

Official:

**R.L. DILWORTH**  
*Brigadier General, United States Army*  
*The Adjutant General*

**CARL E. VUONO**  
*General, United States Army*  
*Chief of Staff*

B. F. MONTOYA,  
Rear Admiral, CEC, US Navy  
Commander  
Naval Facilities Engineering Command

Official:

**ALFRED G. HANSEN**  
*General, USAF, Commander, Air Force*  
*Logistics Command*

**LARRY D. WELCH, General USAF**  
*Chief of Staff*

**H. E. REESE**  
Executive Director  
Marine Corps Research, Development and  
Acquisition Command

**DISTRIBUTION:**

To be distributed in accordance with DA Form 12-25A, Direct Support and General Support Maintenance requirements for Generator Set, Diesel Driven, Tactical, Skid Mounted, 120/208V, 240/416V, 30KW, 3PH, 4 Wire (50/60HZ: MEP-005A, MEP-104A; 400HZ: MEP-114A).

CHANGE }  
 NO. 7 }

DEPARTMENTS OF THE ARMY, THE  
 NAVY, AND THE AIR FORCE (INCLUDING THE  
 US MARINE CORPS)  
 WASHINGTON, D.C., 17 June 1988

Intermediate (Field) (Direct and General  
 Support) and Depot Level Maintenance Manual

GENERATOR SET, DIESEL ENGINE DRIVEN,  
 TACTICAL, SKID MTD., 30 KW, 3 PHASE  
 4 WIRE, 120/208 AND 240/416 VOLTS

DOD MODEL	CLASS	HERTZ	NSN
MEP-005A	Utility	50/60	6115-00-118-1240
MEP-104A	Precise	50/60	6115-00-118-1247
MEP-114A	Precise	400	6115-00-118-1248

INCLUDING OPTIONAL KITS

DOD MODEL	NOMENCLATURE	NSN
MEP-005AWF	Winterization Kit, Fuel Burning	6115-00-463-9083
MEP-005AWE	Winterization Kit, Electric	6115-00-463-9085
MEP-005ALM	Load Bank Kit	6115-00-463-9088
MEP-005AWM	Wheel Mounting Kit	6115-00-463-9094

TM 5-6115-34/NAVFAC P-8-625-34/TO 35C2-3-446-2/TM 06858B/06859D-34,  
 31 January 1975, is changed as follows:

Remove pages

v and vi  
 1-1 and 1-2  
 3-23 and 3-24  
 4-40.3 and 4-40.4  
 5-45 and 5-46  
 7-1 and 7-2  
 ---

Insert pages

v and vi  
 1-1 and 1-2  
 3-23 and 3-24  
 4-40.3 and 4-40.4  
 5-45 and 5-46  
 7-1 and 7-2  
 7-2.1/7-2.2

2. Retain this sheet in front of manual for reference purposes.

TM 5-6115-465-34  
NAVFAC P-8-625-34  
TO 35C2-3-446-2  
TM 06858B/06859D-34  
C7

**By Order of the Secretaries of the Army, the Navy, and the Air Force:**

Official:

**R. L. DILWORTH**  
*Brigadier General, United States Army*  
*The Adjutant General*

**CARL E. VUONO**  
*General, United States Army*  
*Chief of Staff*

**B. F. MONTOYA**  
*Rear Admiral, CEC, US Navy*  
*Commander*  
*Naval Facilities Engineering Command*

Official:

**ALFRED G. HANSEN**  
*General, USAF, Commander, Air Force*  
*Logistics Command*

**LARRY D. WELSH, General USAF**  
*Chief of Staff*

**H. E. REESE**  
*Executive Director*  
*Marine Corps Research, Development and*  
*Acquisition Command*

**DISTRIBUTION:**

To be distributed in accordance with DA Form 12-25A, Direct Support and General Support Maintenance Requirements for Generator Set, Diesel Driven, Tactical, Skid Mounted, 120/208V, 240/416V, 30KW, 3PH, 4 Wire (50/60HZ: MEP-005A, MEP-104A; 400HZ: MEP-114A).

CHANGE }  
 NO. 6 }

DEPARTMENTS OF THE ARMY, THE  
 NAVY, AND THE AIR FORCE (INCLUDING THE  
 US MARINE CORPS)  
 WASHINGTON, D.C., 8 December 1986

Intermediate (Field) (Direct and General  
 Support) and Depot Level Maintenance Manual

GENERATOR SET, DIESEL ENGINE DRIVEN,  
 TACTICAL, SKID MTD., 30 KW, 3 PHASE  
 4 WIRE, 120/208 AND 240/416 VOLTS

DOD MODEL	CLASS	HERTZ	NSN
MEP-005A	Utility	50/60	6115-00-118-1240
MEP-104A	Precise	50/60	6115-00-118-1247
MEP-114A	Precise	400	6115-00-118-1248

INCLUDING OPTIONAL KITS

DOD MODEL	NOMENCLATURE	NSN
MEP-005AWF	Winterization Kit, Fuel Burning	6115-00-463-9083
MEP-005AWE	Winterization Kit, Electric	6115-00-463-9085
MEP-005ALM	Load Bank Kit	6115-00-463-9088
MEP-005AWM	Wheel Mounting Kit	6115-00-463-9094

TM 5-6115-465-34/NAVFAC P-8-625-34/TO 35C2-3-446-2/TM 06858B/06859D-34,  
 31 January 1975, is changed as follows:

1. Remove and insert pages as indicated below. New or changed text material is indicated by a vertical bar in the margin. An illustration change is indicated by a miniature pointing hand.

Remove pages	Insert pages
2-5 and 2-6	2-5 and 2-6
3-73 through 3-76	3-73 through 3-76
4-13 and 4-14	4-13 and 4-14
5-75 and 5-76	5-75 and 5-76
---	5-76.1/5-76.2
8-5 and 8-6	8-5 and 8-6
8-11 and 8-12	8-11 and 8-12
Index 1 and Index 2	Index 1 and Index 2

2. Retain this sheet in front of manual for reference purposes.

TM 5-6115-465-34  
NAVFAC P-8-625-34  
TO 35C2-3-446-2  
TM 06858B/06859D-34  
C6

**By Order of the Secretaries of the Army, the Navy, and the Air Force:**

**JOHN A. WICKHAM, JR.**  
*General, United States Army*  
*Chief of Staff*

Official:

**R. L. DILWORTH**  
*Brigadier General, United States Army*  
*The Adjutant General*

**J. P. JONES, JR.**  
*Rear Admiral, CEC, US Navy*  
*Commander*  
*Naval Facilities Engineering Command*

Official:

**CHARLES A. GABRIEL, General USAF**  
*Chief of Staff*

**EARL T. O'LOUGHLIN**  
*General, USAF, Commander, Air Force*  
*Logistics Command*

**GEORGE B. CRIST**  
*Lieutenant General, USMC*  
*Deputy Chief of Staff for Installation and Logistics*

**DISTRIBUTION:**

To be distributed in accordance with DA Form 12-25A, Direct and General Support Maintenance Requirements for Generator Set, Diesel Driven, Tactical, Skid Mounted, 120/208V, 240/416V, 30KW, 3PH, 4 Wire (50/60HZ: MEP-005A, MEP-104A; 400HZ: MEP-114A) (TM 5-6115-465 Series)



CHANGE }  
 NO. 5 }

DEPARTMENTS OF THE ARMY, THE  
 NAVY, AND THE AIR FORCE (INCLUDING THE  
 US MARINE CORPS)  
 WASHINGTON, D.C., 1 May 1986

Intermediate (Field) (Direct and General  
 Support) and Depot Level Maintenance Manual

GENERATOR SET, DIESEL ENGINE DRIVEN,  
 TACTICAL, SKID MTD., 30 KW, 3 PHASE  
 4 WIRE, 120/208 AND 240/416 VOLTS

DOD MODEL	CLASS	HERTZ	NSN
MEP-005A	Utility	50/60	6115-00-118-1240
MEP-104A	Precise	50/60	6115-00-118-1247
MEP-114A	Precise	400	6115-00-118-1248

INCLUDING OPTIONAL KITS

DOD MODEL	NOMENCLATURE	NSN
MEP-005AWF	Winterization Kit, Fuel Burning	6115-00-463-9083
MEP-005AWE	Winterization Kit, Electric	6115-00-463-9085
MEP-005ALM	Load Bank Kit	6115-00-463-9088
MEP-005AWM	Wheel Mounting Kit	6115-00-463-9094

TM 5-6115-465-34/NAVFAC P-8-625-34/TO 35C2-3-446-2/TM 06858B/06859D-34,  
 31 January 1975, is changed as follows:

1. Remove and insert pages as indicated below. New or changed text material is indicated by a vertical bar in the margin. An illustration change is indicated by a miniature pointing hand.

Remove pages	Insert Pages
i through viii	i through x
1-3 and 1-4	1-3 and 1-4
2-1 and 2-2	2-1 and 2-2
-----	2-2.1 and 2-2.2
2-3 and 2-4	2-3 and 2-4
2-7 and 2-8	2-7 and 2-8
3-49 and 3-50	3-49 and 3-50
4-1 and 4-2	4-1 and 4-2
4-19 and 4-20	4-19 and 4-20
4-25 and 4-26	4-25 and 4-26
4-37 and 4-38	4-37 and 4-38
-----	4-40.1 through 4-40.7/4-40.8
-----	4-44.1 and 4-44.2
5-28.1/5-28.2	5-28.1/5-28.2
5-37 and 5-38	5-37 and 5-38
7-3 and 7-4	7-3 and 7-4

TM 5-6115-465-34  
NAVFAC P-8-625-34  
TO 35C2-3-446-2  
TM 06858B/06859D-34  
C5

2. Retain this sheet in front of manual for reference purposes.

**By Order of the Secretaries of the Army, the Navy, and the Air Force:**

**JOHN A. WICKHAM, JR.**  
*General, United States Army*  
*Chief of Staff*

Official:

**MILDRED E. HEDBERG**  
*Brigadier General, United States Army*  
*The Adjutant General*

**J. P. JONES, JR.**  
*Rear Admiral, CEC, US Navy*  
*Commander*  
*Naval Facilities Engineering Command*

Official:

**CHARLES A. GABRIEL, General USAF**  
*Chief of Staff*

**EARL T. O'LOUGHLIN**  
*General, USAF, Commander, Air Force*  
*Logistics Command*

**GEORGE B. CRIST**  
*Lieutenant General, USMC*  
*Deputy Chief of Staff for Installations and Logistics*

**DISTRIBUTION:**

To be distributed in accordance with DA Form 12-25A, Direct and General Support Maintenance Requirements for Generator Set, Diesel Driven, Tactical, Skid Mounted, 120/208V, 240/416V, 30KW, 3PH, 4 Wire (50/60HZ: MEP-005A, MEP-104A; 400HZ: MEP-114A) (TM 5-6115-465 Series)

TM 5-6115-465-34  
 NAVFAC P-8-625-34  
 TO 35C2-3-446-2  
 TM 06858B/06859D-34  
 C 4

CHANGE }  
 NO. 4 }

DEPARTMENTS OF THE ARMY, THE  
 NAVY, AND THE AIR FORCE (INCLUDING  
 THE US MARINE CORPS)  
 WASHINGTON, D.C., 30 September 1985

Intermediate (Field) (Direct and General  
 Support) and Depot Level Maintenance Manual

GENERATOR SET, DIESEL ENGINE DRIVEN,  
 TACTICAL, SKID MTD., 30 KW, 3 PHASE  
 4 WIRE, 120/208 AND 240/416 VOLTS

DOD MODEL	CLASS	HERTZ	NSN
MEP-005A	Utility	50/60	6115-00-118-1240
MEP-104A	Precise	50/60	6115-00-118-1247
MEP-114A	Precise	400	6115-00-118-1248

INCLUDING OPTIONAL KITS

DOD MODEL	NOMENCLATURE	NSN
MEP-005AWF	Winterization Kit, Fuel Burning	6115-00-463-9083
MEP-005AWE	Winterization Kit, Electric	6115-00-463-9085
MEP-005ALM	Load Bank Kit	6115-00-463-9088
MEP-005AWM	Wheel Mounting Kit	6115-00-463-9094

TM 5-6115-465-34/NAVFAC P-8-625-34/TO 35C2-3-446-2/TM 06858B/06859D-34,  
 31 January 1975, is changed as follows:

1. Remove and insert pages as indicated below. New or changed text material is indicated by a vertical bar in the margin. An illustration change is indicated by a miniature pointing hand.

Remove pages	Insert pages
1-3 and 1-4	1-3 and 1-4
3-5 and 3-6	3-5 and 3-6
3-19 and 3-20	3-19 and 3-20
3-71 and 3-72	3-71 and 3-72
5-23 and 5-24	5-23 and 5-24
5-35 and 5-36	5-35 and 5-36
5-55 and 5-56	5-55 and 5-56

2. Retain this sheet in front of manual for reference purposes.

**By Order of the Secretaries of the Army the Navy, and the Air Force:**

Official:

**JOHN A. WICKHAM, JR.**  
*General, United States Army*  
*Chief of Staff*

**DONALD J. DELANDRO**  
*Brigadier General, United States Army*  
*The Adjutant General*

**J. P. JONES, JR.**  
*Rear Admiral, CEC, US Navy*  
*Commander*  
*Naval Facilities Engineering Command*

Official:

**CHARLES A. GABRIEL, General USAF**  
*Chief of Staff*

**EARL T. O'LOUGHLIN**  
*General, USAF, Commander, Air Force*  
*Logistics Command*

**GEORGE B. CRIST**  
*Lieutenant General, USMC*  
*Deputy Chief of Staff for Installation and Logistics*

**DISTRIBUTION:**

To be distributed in accordance with DA Form 12-25D, Direct and General Support Maintenance Requirements for 30 KW, 60 HZ, Precise Power, and 30 KW, 400 HZ Precise Power.

CHANGE }  
 NO. 3 }

DEPARTMENTS OF THE ARMY, THE NAVY,  
 AND THE AIR FORCE  
 (INCLUDING THE US MARINE CORPS)  
 WASHINGTON, D.C., 9 January 1985

Intermediate (Field) (Direct and General  
 Support) and Depot Level Maintenance Manual

GENERATOR SET, DIESEL ENGINE DRIVEN,  
 TACTICAL, SKID MTD., 30 KW, 3 PHASE  
 4 WIRE, 120/203 AND 240/416 VOLTS

DOD MODEL	CLASS	HERTZ	NSN
MEP-005A	Utility	50/60	6115-00-118-1240
MEP-104A	Precise	50/60	6115-00-118-1247
MEP-114A	Precise	400	6115-00-118-1248

INCLUDING OPTIONAL KITS

DOD MODEL	NOMENCLATURE	NSN
MEP-005AWF	Winterization Kit, Fuel Burning	6115-00-463-9083
MEP-005AWE	Winterization Kit, Electric	6115-00-463-9085
MEP-005ALM	Load Bank Kit	6115-00-463-9088
MEP-005AWM	Wheel Mounting Kit	6115-00-463-9094

TM 5-6115-465-34/NAVFAC P-8-625-34/TO 35C2-3-446-2/TM 06858B/06859D-34,  
 31 January 1975, is changed as follows:

- Title is changed as shown above.
- Remove and insert pages as indicated below. New or changed text material is indicated by a vertical bar in the margin. An illustration change is indicated by a miniature pointing hand.

Remove pages	Insert pages
1-1 and 1-2	1-1 and 1-2
2-5 and 2-6	2-5 and 2-6
----	2-6.1/2-6.2
3-37 and 3-38	3-37 and 3-38
3-57 through 3-60	3-57 through 3-60
----	3-60.1 through 3-60.3/3-60.4
3-71 and 3-72	3-71 and 3-72
5-17 and 5-18	5-17 and 5-18
5-27 and 5-28	5-27 and 5-28
5-57 and 5-58	5-57 and 5-58
5-69 and 5-70	5-69 and 5-70
A-1 and A-2	A-1 and A-2

TM 5-6115-465-34  
NAVFAC P-8-625-34  
TO 35C2-3-446-2  
TM 06858B/06859D-34

C 3

3. New or changed text material is indicated by a vertical bar in the margin. An illustration change is indicated by a miniature pointing hand.

4. Retain this sheet in front of manual for reference purposes

**By Order of the Secretaries of the Army, the Navy, and the Air Force:**

**JOHN A. WICKHAM, JR.**  
*General, United States Army*  
*Chief of Staff*

Official:

**DONALD J. DELANDRO**  
*Brigadier General, United States Army*  
*The Adjutant General*

**W. M. ZOBEL**  
*Rear Admiral, CEC, US Navy*  
*Commander*  
*Naval Facilities Engineering Command*

Official:

**CHARLES A. GABRIEL, General USAF**  
*Chief of Staff*

**JAMES P. MULLINS, General, USAF**  
*Air Force Logistics Command*

**H. A. HATCH**  
*Lieutenant General, USMC*  
*Deputy Chief of Staff for*  
*Installations and Logistics*

**DISTRIBUTION:**

To be distributed in accordance with DA Form 12-25D, Direct and General Support Maintenance requirements for 30 KW, 60 HZ, Precise Power, and 30 KW, 400 KW, 60 HZ Precise Power.

Marine Corps: MARCORPS AGC

Change }  
 No. 2 }

DEPARTMENTS OF THE ARMY, THE NAVY,  
 AND THE AIRFORCE  
 (INCLUDING THE US MARINE CORPS)  
 WASHINGTON, DC., 17 March 1981

**Intermediate (Field) (Direct and General  
 Support) and Depot Level Maintenance Manual**

**GENERATOR SET, DIESEL ENGINE DRIVEN,  
 TACTICAL, SKID MTD., 30KW, 3 PHASE,  
 4 WIRE, 120/208 AND 240/416 VOLTS**

DOD MODEL	CLASS	HERTZ	NSN
MEP-005A	UTILITY	50/60	6115-00-118-1240
MEP-104A	PRECISE	50/60	6115-00-118-1247
MEP-114A	PRECISE	50/60	6115-00-118-1248

**INCLUDING OPTIONAL KITS  
 NOMENCLATURE**

DOD MODEL		NSN
MEP-005AWF	WINTERIZATION KIT, FUEL BURNING	6115-00-463-9083
MEP-005AWE	WINTERIZATION KIT, ELECTRIC	6115-00463-9085
MEP-005ALM	LOAD BANK KIT	6115-00-463-9088
MEP-005AWM	WHEEL MOUNTING KIT	6115-00463-9094

TM5-6115-465-34/NAVFAC P-8-625-34/T.O. 35C2-3-446-2/TM 06858B/06859D-34,  
 31 January 1975, is changed as follows:

- Remove and insert pages as indicated below.
 

	Remove pages	Insert pages
Table of Contents	i thru viii	i thru viii
Chapter 1	1-7 and 1-8	1-7 and 1-8
Chapter 2	2-11/2-12	2-11/2-12
Chapter 3	3-5 and 3-6	3-5 and 3-6
		3-6.1 thru 3-6.5/3-6.6
		3-18.1 and 3-18.2
	3-19 thru 3-24	3-19 thru 3-24
	3-55 and 3-56	3-55 and 3-56
Chapter 4	4-11 and 4-12	4-11 and 4-12
		4-38.1/4-38.2
Chapter 5	5-9 and 5-10	5-9 and 5-10
		5-12.1 thru 5-12.4
	5-13 and 5-14	5-13 and 5-14
	5-19 and 5-20	5-19 and 5-20
		5-28.1/5-28.2
	5-29 and 5-30	5-29 and 5-30
	5-39 and 5-40	5-39 and 5-40
	5-43 thru 5-54	5-43 thru 5-54

	Remove pages	Insert pages
Chapter 5	5-67 and 5-68 5-75 and 5-76	5-67 and 5-68 5-75 and 5-76
Chapter 6	6-1 and 6-2 6-3 and 6-4	6-1 and 6-2 6-2.1/6-2.2 6-3 and 6-4
INDEX	INDEX 1 thru INDEX 4	INDEX 1 thru INDEX 4

2. New or changed text material is indicated by a vertical bar in the margin. An illustration change is indicated by a miniature pointing hand.

3. Retain these sheets in front of manual for reference purposes.

By Order of the Secretaries of the Army, the Navy, and the Air Force:

Official: E. C. MEYER  
General, United States Army  
Chief of Staff

J. C. PENNINGTON  
Major General, United States Army  
The Adjutant General

D. G. ISELIN  
Rear Admiral, CEC, US Navy  
Commander  
Naval Facilities Engineering Command

Official: LEW ALLEN, JR., General USAF  
Chief of Staff

VAN L. CRAWFORD, JR., Colonel, USAF  
Director of Administration

H. A. HATCH  
Major General, USMC  
Deputy Chief of Staff for Installations and Logistics

DISTRIBUTION:  
Active Army:

To be distributed in accordance with DA Form 12-25D, Direct and General Support Maintenance Requirements for Generator Sets, Engine Driven; 30 KW 60 HZ Precise Power and 30 KW 400 HZ Precise Power.

Marine Corps:  
MARCORPS CODE: AGC



C 1

CHANGE }  
 No. 1 }

DEPARTMENTS OF THE ARMY, THE NAVY,  
 AND THE AIR FORCE  
 (INCLUDING THE US MARINE CORPS)  
 WASHINGTON, DC, 10 January 1977

Intermediate (Field) (Direct and General  
 Support) and Depot Level Maintenance Manual

GENERATOR SET, DIESEL ENGINE DRIVEN,  
 TACTICAL, SKID MTD., 30 KW, 3 PHASE,  
 4 WIRE, 120/208 AND 240/416 VOLTS

DOD MODEL	CLASS	HERTZ	NSN
MEP-005A	UTILITY	50/60	611540-118-1240
MEP-104A	PRECISE	50/60	6115-00-118-1247
MEP-114A	PRECISE	50/60	6115-00-118-1248

DOD MODEL	INCLUDING OPTIONAL KITS NOMENCLATURE	NSN
MEP-005AWF	WINTERIZATION KIT, FUEL BURNING	6115-00-463-9083
MEP-005AWE	WINTERIZATION KIT, ELECTRIC	6115-00-463-9085
MEP-005ALM	LOAD BANK KIT	6115-00-463-9088
MEP-005AWM	WHEEL MOUNTING KIT	6115-00-463-9094

TM 5-6115-465-34/NAVFAC P-8-625-34/TO 35C2-446-2/TM 06858B/06869D-34 91 January 1976, is changed as follows:

1. Remove old pages and insert new pages as indicated below. New or changed material is indicated by a vertical bar in the margin of the page. Added or revised illustrations are indicated by a vertical bar adjacent to the identification number.

<i>Remove pages</i>	<i>Insert pages</i>
Warning page and A	Warning page and A
1-1 and 1-2	1-1 and 1-2
3-21 and 3-22	3-21 and 3-22
3-69 and 3-70	3-69 and 3-70
3-75 and 3-76	3-75 and 3-76
5-47 and 5-48	5-47 and 5-48
5-53 and 5-54	5-53 and 5-54
None	DA Form 2028-2

2. File this change sheet in front of the publication for reference purposes.

**By Order of the Secretaries of the Army, the Navy, and the Air Force:**

**BERNARD W. ROGERS**  
*General, United States Army*  
*Chief of Staff*

Official:

**PAUL T. SMITH**  
*Major General, United States Army*  
*The Adjutant General*

**A. R. MARSCHALL,**  
*Rear Admiral, CEC, U.S. Navy*  
*Commander, Naval Facilities*  
*Engineering Command*

Official:

**DAVID C JONES, General, USAF**  
*Chief of Staff*

**JAMES J. SHEPARD, Colonel, USAF**  
*Director of Administration*

**J. R. JONES**  
*Major General, U. S. Marine Corps*  
*Deputy Chief of Staff for Installations and Logistics*

Distribution:

*Active Army:*

To be distributed in accordance with DA Form 12-25D, direct and general support maintenance requirements for generator sets, engine driven 30 kw 60 Hz precise power and 30 kw 400 Hz precise power.

*Marine Corp: MARCORPS AGC*

### **WARNING**

All specific cautions and warnings contained in this manual shall be strictly adhered to. Otherwise, severe injury, death and/or damage to the equipment may result.

### **HIGH VOLTAGE**

is produced when this generator set is in operation.

### **DEATH**

or severe burns may result if personnel fail to observe safety precautions. Do not operate this generator set until the ground terminal stud has been connected to a suitable ground. Disconnect the battery ground cable before removing and installing components on the engine or in the electrical control panel system. Do not attempt to service or otherwise make any adjustments, connections or reconnections of wires or cables until generator set is shutdown and completely deenergized.

### **DANGEROUS GASES**

Batteries generate explosive gas during charging; therefore, utilize extreme caution, do not smoke, or use open flame in vicinity when servicing batteries. Exhaust discharge contains noxious and deadly fumes. Do not operate generator sets in enclosed areas unless exhaust discharge is properly vented to the outside. When filling fuel tank, maintain metal-to-metal contact between filler nozzle and fuel tank. Do not smoke or use an open flame in the vicinity. Use extreme care, should a selenium rectifier malfunction, to avoid inhalation of poisonous fumes.

### **LIQUIDS UNDER PRESSURE**

are generated as a result of operation of the generator set. Do not expose any part of the body to a high pressure leak in the fuel or hydraulic system of the generator set. Relieve pressure from radiator before removing radiator cap.

### **NOISE**

operating level of this generator can cause hearing damage. Ear protectors, as recommended by the medical or safety officer, must be worn when working near this set.

### **CAUTION**

### **DAMAGE**

to the equipment may result if personnel fail to observe the cautions contained in this manual. If generator set is shut down by the operation of a safety device, do not attempt to operate the unit until the cause has been determined and eliminated.

### **WARNING**

Hot refueling of generators while they are running poses a safety hazard and should not be attempted.

Hot engine surfaces and sparks produced from the engine and generator circuitry are possible sources of ignition. Severe injury, death and/or damage to the equipment may result.



Reproduction for non-military use of the information or illustrations contained in this publication is not permitted. The policy for military use reproduction is established for the Army in AR 380-5, for the Navy and Marine Corps in OPNAVINST 5510.1B, and for the Air Force in Air Force Regulation 205-1.

**LIST OF EFFECTIVE PAGES**

Insert latest changed pages; dispose of superseded pages in accordance with applicable regulations.

Total number of pages in this manual is 312 consisting of the following:

<i>Page No.</i>	<i>*Change No.</i>
Warning .....	.1
A .....	.1
i through viii .....	.0
1-1 .....	.1
1-2 through 1-11/(1-12 blank) .....	.0
2-1 through 2-11/(2-12 blank) .....	.0
3-1 through 3-20 .....	.0
3-21 .....	.1
3-22 through 3-69) .....	.0
3-70 .....	.1
3-71 through 3-74 .....	.0
3-75 .....	.1
3-76 through 3-80 .....	.0
4-1 through 4-28 .....	.0
4-28.1 and 4-28.2 .....	.0
4-29 through 4-52 .....	.0
5-1 through 5-46 .....	.0
5-47 .....	.1
5-48 through 5-53 .....	.0
5-54 .....	.1
5-55 through 5-75/(5-76 blank) .....	.0
6-1 through 6-5/(6-6 blank) .....	.0
7-1 through 7-17/(7-18 blank) .....	.0
8-1 through 8-38 .....	.0
A-1 and A-2 .....	.0
INDEX 1 through INDEX 4 .....	.0

Zero in this column indicates an original page.



		Page
LIST OF ILLUSTRATIONS .....		vii
CHAPTER 1.	INTRODUCTION .....	1-1
Section I.	GENERAL .....	1-1
	1-1. Scope .....	1-1
	1-2. Forms and Records .....	1-1
	1-3. Demolition to Prevent Enemy Use .....	1-1
	1-4. Shipment and Storage .....	1-1
Section II.	DESCRIPTION AND DATA .....	1-2
	1-5. Description .....	1-2
	1-6. Tabulated Data .....	1-2
CHAPTER 2.	GENERAL MAINTENANCE INSTRUCTIONS .....	2-1
Section I.	REPAIR PARTS, SPECIAL TOOLS AND EQUIPMENT .....	2-1
	2-1. Tools and Support Equipment .....	2-1
	2-2. Direct Support, General Support, and Depot Maintenance Repair Parts .....	2-1
	2-3. Fabricated Tools and Equipment .....	2-1
Section II.	TROUBLESHOOTING .....	2-3
	2-4. General .....	2-3
Section III.	REMOVAL AND INSTALLATION OF MAJOR COMPONENTS .....	2-9
	2-5. General .....	2-9
	2-6. Engine Assembly Removal and Installation .....	2-9
	2-7. Generator Assembly .....	2-11
CHAPTER 3.	ENGINE REPAIR INSTRUCTIONS .....	3-1
Section I.	ENGINE ELECTRICAL SYSTEM .....	3-1
	3-1. General .....	3-1
	3-2. Batteries .....	3-1
	3-3. Slave Receptacle .....	3-1
	3-4. Starter Assembly .....	3-1
	3-4.1 Starter Assembly (Effective with Serial No. RZ70001 and KZ00001 thru KZ02752) .....	3-5
	3-5. Battery Charging Alternator .....	3-7
	3-6. Speed Switch .....	3-18
	3-6.1 Speed Switch (Effective with Serial No. RZ70001 and KZ00001 thru KZ02752) .....	3-18.2
	3-7. Coolant Temperature Transmitter .....	3-20

		TABLE OF CONTENT (CONT)	Page
	3-8.	Overtemperature Switch .....	3-20
	3-9.	Oil Pressure Transmitter.....	3-20
	3-10.	Low Oil Pressure Switch.....	3-20
	3-11.	Day Tank Fuel Level and Low Fuel Cutoff Switch .....	3-20
	3-12.	Fuel Solenoid Valve .....	3-20
	3-13.	Engine 'Airing Harness Assembly .....	3-20
Section	II.	ENGINE FUEL SYSTEM .....	3-22
	3-14.	General .....	3-22
	3-15.	Main Fuel Tank .....	3-22
	3-16.	Fuel Transfer Pumps .....	3-22
	3-17.	Fuel Strainer and Filter Assembly .....	3-22
	3-18.	Day Tank Assembly .....	3-23
	3-19.	Secondary Fuel Filter Assembly .....	3-23
	3-20.	Fuel Injection Pump Assembly .....	3-25
	3-21.	Fuel Injection Nozzle Holders and Lines .....	3-38
	3-22.	Fuel Lines .....	3-39
	3-23.	Start Aid Assembly .....	3-39
Section	III.	ENGINE COOLING SYSTEM .....	3-41
	3-24.	General .....	3-41
	3-25.	Grille .....	3-41
	3-26.	Shutter Control Assembly .....	3-41
	3-27.	Radiator .....	3-41
	3-28.	Shutter Assembly .....	3-42
	3-29.	Cooling Fan .....	3-43
	3-30.	Water Pump .....	3-43
	3-31.	Coolant Thermostat and Housing .....	3-45
Section	IV.	ENGINE LUBRICATION SYSTEM .....	3-45
	3-32.	General .....	3-45
	3-33.	Lubrication Oil Filter .....	3-45
	3-34.	Oil Level Gauge .....	3-45
	3-35.	Oil Cooler Assembly (400 Hz Sets only) .....	3-45
	3-36.	Oil Pan Assembly .....	3-45
	3-37.	Oil Pump Assembly .....	3-46
Section	V.	HYDRAULIC SYSTEM .....	3-50
	3-38.	General .....	3-50
	3-39.	Hydraulic Sump .....	3-50
	3-40.	Hydraulic Pump Assembly .....	3-50
	3-41.	Hydraulic System Filter Assembly .....	3-54
	3-42.	Hydraulic Actuator Unit .....	3-56



TABLE OF CONTENTS (CONT)		Page
Section VI.	INTAKE AND EXHAUST SYSTEMS AND BREATHER.....	3-61
	3-43. General .....	3-61
	3-44. Air Cleaner Assembly .....	3-61
	3-45. Exhaust Pipe and Muffler .....	3-61
	3-46. Breather and Breather Tube .....	3-61
Section VII.	ENGINE ASSEMBLY .....	3-61
	3-47. General .....	3-61
	3-48. Engine Front Support .....	3-62
	3-49. Flywheel and Flywheel Housing .....	3-62
	3-50. Timing Gears and Cover .....	3-64
	3-51. Intake Manifold .....	3-66
	3-52. Exhaust Manifold .....	3-66
	3-53. Cylinder Head and Rocker Arm Assembly .....	3-67
	3-54. Camshaft .....	3-70
	3-55. Crankshaft, Connecting Rods, and Pistons .....	3-75
	3-56. Cylinder Block Assembly .....	3-78
CHAPTER 4.	GENERATOR SET CONTROLS AND INTERCONNECTING WIRING HARNESS REPAIR INSTRUCTIONS .....	4-1
Section I.	GENERATOR SET CONTROLS .....	4-1
	4-1. General .....	4-1
	4-2. Control Cubicle Assembly .....	4-1
	4-3. Fault Locating Indicator .....	4-7
	4-4. Manual Speed Control .....	4-17
	4-5. DC Control Circuit Breaker .....	4-17
	4-6. Load Measuring Unit .....	4-17
	4-7. Governor Control Unit .....	4-20
	4-7.1 Governor Control Unit (MEP-114A) .....	4-40.1
	4-7.2 Actuator Unit .....	4-40.4
	4-7.3 Electric Governor Magnetic Pickup .....	4-40.4
Section II.	INTERCONNECTING WIRING HARNESES .....	4-41
	4-8. General .....	4-41
	4-9. Tactical Relay Assembly to Special Relay Assembly Wiring Harness .....	4-41
	4-10. Special Relay Assembly to Static Exciter Wiring Harness .....	4-41
	4-11. Load Measuring Unit to Tactical Relay Assembly Wiring Harness .....	4-41
	4-12. Governor Control Unit to Hydraulic Actuator Unit Wiring Harness .....	4-41
	4-13. AC Power Control Wiring Harness .....	4-41
	4-14. Exciter Control Wiring Harness .....	4-41
	4-15. Special Relay Assembly to Fault Locating Indicator Wiring Harness .....	4-49

TABLE OF CONTENTS (CONT)		Page
4-16.	Special Relay Assembly to Control Cubicle Assembly Wiring Harness .....	4-49
4-17.	Precise Relay Assembly to Governor Control Unit Wiring Harness .....	4-49
4-18.	Special Relay Assembly to Precise Relay Assembly Wiring Harness .....	4-49
CHAPTER 5.	GENERATOR REPAIR INSTRUCTIONS .....	5-1
Section I.	CONVENIENCE AND PARALLELING RECEPTACLES AND WIRING HARNESS .....	5-1
5-1.	General .....	5-1
5-2.	Convenience Receptacle and Circuit Breaker . . .	5-1
5-3.	Convenience and Paralleling Receptacles Wiring Harness .....	5-1
Section II.	LOAD CONNECTION GROUP .....	5-1
5-4.	General .....	5-1
5-5.	Voltage Reconnection Board Assembly .....	5-1
5-6.	Main Load Contactor .....	5-1
5-6.1	Main Load Contactor (Effective with Serial No. RZ70001 and KZ00001 thru KZ02752) . . . . .	5-12.1
5-7.	Load Terminal Board Assembly .....	5-13
5-8.	Current Transformer Assemblies .....	5-13
Section III.	RELAY TABLE COMPONENTS .....	5-17
5-9.	General .....	5-17
5-10.	Tactical Relay Assembly .....	5-17
5-11.	Special Relay Assembly .....	5-25
5-12.	Precise Relay Assembly .....	5-28
5-13.	Static Exciter and Voltage Regulator Assembly .	5-37
5-14.	Relay Table Components Adjustments .....	5-47
Section IV.	GENERATOR ASSEMBLIES .....	5-55
5-15.	General .....	5-55
5-16.	Generator Maintenance Instructions .....	5-55
Section V.	ELECTROMAGNETIC INTERFERENCE SUPPRESSION COMPONENTS . . . .	5-76.1
5-17.	Testing for Electromagnetic Interference . . . . .	5-76.1
5-18.	Replacement of Interference Suppression Components .....	5-76.1
CHAPTER 6.	ENCLOSURE ASSEMBLY REPAIR INSTRUCTIONS .....	6-1
Section I.	HOUSING ASSEMBLY .....	6-1
6-1.	General .....	6-1
6-2.	Relay Table Maintenance .....	6-1

TABLE OF CONTENTS (CONT)

	Page
Section IV. LOAD BANK .....	8-25
8-20. General .....	8-25
8-21. Control Box Assembly .....	8-25
8-22. Load Bank Housing .....	8-25
8-23. Wiring Harness .....	8-26
Section V. ACOUSTIC SUPPRESSION KIT .....	8-39
8-24. General .....	8-39
8-25. Acoustic Suppression Kit, Installation and Removal .....	8-39
APPENDIX A. REFERENCES	

LIST OF ILLUSTRATIONS

Figure	Title	Page
2-1.	Engine assembly, removal and Installation .....	2-8
2-2.	Generator assembly, removal and installation .....	2-10
3-1.	Starter assembly, exploded view .....	3-2
3-2.	Starter assembly motoring test circuit .....	3-6
3-3.	Starter assembly stalled torque setup .....	3-6
3-4.	Alternator assembly, exploded view .....	3-8
3-5.	Rotor assembly current draw test circuit .....	3-10
3-6.	Alternator test leads installation .....	3-12
3-7.	Total circuit voltage test .....	3-13
3-8.	Alternator positive output circuit test .....	3-14
3-9.	Alternator negative output circuit test .....	3-14
3-10.	Recitation voltage test .....	3-15
3-11.	Faulty voltage regulator circuit test .....	3-16
3-12.	Field current test .....	3-16
3-13.	Output and voltage protector test .....	3-17
3-14.	Speed switch, exploded view .....	3-18
3-15.	Speed switch test points .....	3-20
3-16.	Engine wiring harness assembly, drawing no. 72-2284 . . .	3-21
3-17.	Main fuel tank, removal and installation .....	3-23
3-18.	Fuel Injection pump, removal and installation .....	3-24
3-19.	Fuel injection pump, exploded view .....	3-26
3-20.	Adjusting fuel injection pump roller-to-roller dimension .....	3-32
3-21.	Throttle linkage adjustment .....	3-35
3-22.	Solenoid armature adjustments .....	3-36
3-23.	Fuel Injection nozzle holder, exploded view .....	3-38
3-24.	Shutter control assembly, exploded view .....	3-40

TABLE OF CONTENTS (CONT)

	Page
CHAPTER 8. REPAIR INSTRUCTIONS FOR MATERIAL USED IN CONJUNCTION WITH THE GENERATOR SET. . . . .	8-1
Section I. FUEL BURNING WINTERIZATION KIT . . . . .	8-1
8-1. General . . . . .	8-1
8-2. Troubleshooting . . . . .	8-1
8-3. Heater Control Assembly . . . . .	8-3
8-4. Heater Assembly . . . . .	8-3
8-5. Coolant Lines and Fittings. . . . .	8-12
8-6. Wiring Harness Assemblies . . . . .	8-12
Section II. ELECTRIC WINTERIZATION KIT . . . . .	8-12
8-7. General . . . . .	8-12
8-8. Troubleshooting . . . . .	8-12
8-9. Heater Control Assembly . . . . .	8-13
8-10. Heater Assembly . . . . .	8-16
8-11. Coolant Pump and Motor Assembly . . . . .	8-16
8-12. Coolant Lines and Fittings . . . . .	8-16
8-13. Wiring Harness . . . . .	8-19
Section III. WHEEL MOUNTING KIT . . . . .	8-21
8-14. General . . . . .	8-21
8-15. Wheel Mounting Kit Installation and Removal. . . . .	8-21
8-16. Wheels and Tires . . . . .	8-21
8-17. Wheel Bearings . . . . .	8-21
8-18. Axle Assemblies . . . . .	8-21
Section IV. LOAD BANK . . . . .	8-25
8-20. General . . . . .	8-25
8-21. Control Box Assembly . . . . .	8-25
8-22. Load Bank Housing . . . . .	8-25
8-23. Wiring Harnesses . . . . .	8-26
Section V. ACOUSTIC SUPPRESSION KIT . . . . .	8-39
8-24. General . . . . .	8-39
8-25. Acoustic Suppression Kit, Installation and Removal . . . . .	8-39
APPENDIX A. REFERENCES . . . . .	A-1

LIST OF ILLUSTRATIONS

Figure	Title	Page
2-0.	Breakout Cable .....	2-2.2
2-1.	Engine assembly, removal and installation .....	2-8
2-2.	Generator assembly, removal and installation .....	2-10
3-1.	Starter assembly, exploded view .....	3-2
3-2.	Starter assembly motoring test circuit .....	3-6
3-3.	Starter assembly stalled torque setup .....	3-6
3-3.1	Starter assembly, exploded view (Effective with Serial No. RZ70001 and KZ00001 thru KZ02752) .....	3-6.1
3-4.	Alternator assembly, exploded view .....	3-8
3-5.	Rotor assembly current draw test circuit .....	3-10
3-6.	Alternator test leads installation .....	3-12
3-7.	Total circuit voltage test .....	3-13
3-8.	Alternator Positive output circuit test .....	3-14
3-9.	Alternator negative output circuit test .....	3-14
3-10.	Excitation voltage test .....	3-15
3-11.	Faulty voltage regulator circuit test .....	3-16
3-12.	Field current test .....	3-16
3-13.	Output and voltage protector test .....	3-17
3-14.	Speed switch, exploded view .....	3-18
3-14.1	Speed switch, exploded view (Effective with Serial No. RZ70001 and KZ00001 thru KZ02752) .....	3-18.2
3-15.	Speed switch test points .....	3-20
3-16.	Engine wiring harness assembly, drawing no. 72-2284 .....	3-21
3-17.	Main fuel tank, removal and installation .....	3-23
3-18.	Fuel injection pump assembly, removal and installation .....	3-24
3-19.	Fuel injection pump, exploded view .....	3-26
3-20.	Adjusting fuel injection pump roller-to-roller dimension .....	3-32
3-21.	Throttle linkage adjustment .....	3-35
3-22.	Solenoid armature adjustments .....	3-36
3-23.	Fuel injection nozzle holder, exploded view .....	3-38
3-24.	Shutter control assembly, exploded view .....	3-40
3-25.	Shutter assembly, exploded view .....	3-42
3-26.	Water pump assembly, exploded view .....	3-43
3-27.	Checking impeller to cover plate clearance .....	3-44
3-28.	Oil cooler assembly, removal and installation .....	3-46
3-29.	Oil pan assembly .....	3-47
3-30.	Oil Pump assembly, exploded view .....	3-48
3-31.	Oil pump assembly dimension .....	3-49
3-32.	Hydraulic sump, removal and installation .....	3-51
3-33.	Hydraulic pump assembly, exploded view .....	3-52
3-34.	Hydraulic system filter assembly, exploded view .....	3-53
3-35.	Hydraulic actuator unit, removal and installation .....	3-55
3-36.	Hydraulic actuator unit, exploded view .....	3-57
3-37.	Transducer and armature coil schematic diagram .....	3-58
3-38.	Hydraulic actuator test .....	3-59
3-39.	Engine front support, removal and Installation .....	3-62
3-40.	Flywheel and flywheel housing, exploded view .....	3-63
3-41.	Checking flywheel concentricity and alignment .....	3-64
3-42.	Timing gears and cover, exploded view .....	3-65
3-43.	Timing gear relationships .....	3-67
3-44.	Cylinder head and rocker arm assembly, exploded view .....	3-68

LIST OF ILLUSTRATIONS (CONT)

Figure	Title	Page
3-45.	Rocker arm mounting blocks installation .....	3-71
3-46.	Rocker arm shaft positioning .....	3-71
3-47.	Cylinder head nut tightening sequence .....	3-72
3-48.	Camshaft, exploded view .....	3-73
3-49.	Dimensional inspection of camshaft .....	3-74
3-50.	Crankshaft, connecting rods and pistons, exploded view .....	3-76
3-51.	Cylinder block assembly, exploded view .....	3-79
4-1.	Frequency meter and transducer test setup .....	4-1
4-2.	Thermal watt converter test circuit schematic .....	4-2
4-3.	Control cubicle housing assembly, exploded view.....	4-4
4-4.	Control cubicle relay assembly, exploded view .....	4-5
4-5.	Control cubicle relay assembly schematic diagram .....	4-6
4-6.	Control cubicle wiring harness, drawing no. 69-677 .....	4-8
4-7.	Fault locating indicator, exploded view .....	4-11
4-8.	Fault locating indicator schematic diagram.....	4-13
4-9.	Fault locating indicator component board assembly .....	4-14
4-10.	Fault locating indicator wiring harness, drawing no. 72-2247.	4-15
4-11.	Load measuring unit, exploded view .....	4-16
4-12.	Load measuring unit wiring harness, drawing no. 69-511 .....	4-18
4-13.	Load measuring unit component test and replacement diagram . .	4-19
4-14.	Load measuring unit test circuit and test data relationship .	4-21
4-15.	Governor control unit, exploded view .....	4-23
4-16.	50/60 Hz governor control unit wiring harness, drawing no. 69-731 .....	4-27
4-17.	400 Hz governor control unit wiring harness, drawing no. 69-814 .....	4-28.1
4-18.	Governor control unit printed circuit board .....	4-29
4-19.	50/60 Hz governor control unit wiring diagram, drawing no. 69-730 .....	4-30
4-20.	400 Hz governor control unit wiring diagram, drawing no. 69-833 .....	4-31
4-21.	50/60 Hz governor control unit schematic diagram, drawing no. 69-729 .....	4-32
4-22.	400 Hz governor control unit schematic diagram, drawing no. 69-812 .....	4-33
4-23.	Positioning of unpotted governor control unit during testing .....	4-34
4-24.	Governor control unit magnetic bias test circuit.....	4-34
4-25.	Governor control unit frequency sensing test circuit .....	4-35
4-26.	Governor control unit rectifier bridge and feedback winding test circuit .....	4-36
4-27.	Governor control unit parallel winding test circuit .....	4-37
4-28.	Approximate position of controls for connecting actuator ....	4-38
4-28.1	Approximate position of controls for connecting actuator (Effective with Serial No. RZ70001 and KZ00001 thru KZ02752) .....	4-38.1
4-29.	Governor control unit control panel .....	4-39

LIST OF ILLUSTRATIONS (CONT)

Figure	Title	Page
4-30.	Tactical relay assembly to special relay assembly wiring harness, drawing no. 72-2224 . . . . .	4-40
4-30.1	Functional theory of operation . . . . .	4-40.2
4-30.2	Governor control unit removal and installation . . . . .	4-40.5
4-30.3	Actuator removal and installation . . . . .	4-40.6
4-30.4	Magnetic pick up removal and installation . . . . .	4-40.7
4-31.	Special relay assembly to static exciter assembly wiring harness, drawing no. 72-2220 . . . . .	4-42
4-32.	Load measuring unit to tactical relay assembly wiring harness, drawing no. 72-2234 . . . . .	4-43
4-33.	Governor control unit to hydraulic actuator unit wiring harness, drawing no. 72-2282 . . . . .	4-44
4-33.1	400 Hz electric governor system wiring harness assembly drawing no. 84-704 . . . . .	4-44.1
4-34.	AC power control wiring harness, drawing no. 72-2259 . . . . .	4-45
4-35.	Exciter control wiring harness, drawing no. 73-2288 . . . . .	4-47
4-36.	Special relay assembly to fault locating indicator wiring harness, drawing no. 76-2247 . . . . .	4-48
4-37.	Special relay assembly to control cubical wiring harness, drawing no. 72-2248 . . . . .	4-40
4-38.	Precise relay assembly to governor control unit wiring harness, drawing no. 72-2245 . . . . .	4-51
4-39.	Special relay assembly to precise relay assembly wiring harness, drawing no. 72-2238 . . . . .	4-52
5-1.	Convenience and paralleling receptacles wiring harness, drawing no. 72-2286 . . . . .	5-2
5-2.	Main load contactor, exploded view . . . . .	5-3
5-3.	Actuator assembly adjustment points . . . . .	5-7
5-4.	Main contact preload check points . . . . .	5-8
5-5.	Main load contactor adjustments. . . . .	5-8
5-6.	Main load contactor schematic diagram, contactor to load terminals wiring harness, drawing no. 72-2290, and contactor to reconnection board wiring harness, drawing no. 72-2225 . . . . .	5-9
5-7.	Load terminal board assembly, exploded view . . . . .	5-12
5-7.1	Main load contactor, exploded view (Effective with Serial No. RZ70001 and KZ00001 thru KZ02752) . . . . .	5-12.1
5-8.	Routing of generator leads through current transformers . . . . .	5-14
5-9.	Current transformers, removal and installation . . . . .	5-15
5-10.	Current transformers test points . . . . .	5-16
5-11.	Tactical relay assembly, exploded view . . . . .	5-18
5-12.	Tactical relay assembly wiring harness, drawing no. 72-2243 . . . . .	5-19
5-13.	Reverse power relay test circuit. . . . .	5-21
5-14.	Overvoltage relay test circuit . . . . .	5-22
5-15.	Short circuit relay test circuit . . . . .	5-23
5-16.	Overload protective device test circuit . . . . .	5-24
5-17.	Tactical relay resistor assembly schematic diagram . . . . .	5-25
5-18.	Tactical relay resistor assembly, exploded view . . . . .	5-26
5-19.	Special relay assembly, exploded view . . . . .	5-27
5-19.1	Connector, Plug, Electrical . . . . .	5-28.1

LIST OF ILLUSTRATIONS (CONT)

Figure	Title	Page
5-20.	Special relay assembly, wiring harness, drawing no. 72-2239 .	5-28.1
5-21.	DC relay assembly schematic diagram .....	5-32
5-22.	DC relay assembly, exploded view.....	5-33
5-23.	Precise relay assembly, exploded view.....	5-34
5-24.	Undervoltage relay test circuit .....	5-35
5-25.	Under frequency relay test circuit .....	5-36
5-26.	Permissive paralleling relay test circuit .....	5-37
5-27.	Electronic components assembly .....	5-38
5-28.	50/60 Hz precise relay assembly wiring harness, drawing no. 72-2242 .....	5-39
5-29.	400 Hz precise relay assembly wiring harness, drawing no. 72-2260 .....	5-41
5-30.	Static exciter and voltage regulator assembly, exploded view.....	5-43
5-31.	50/60 Hz static exciter and voltage regulator assembly schematic diagram, drawing no. 72-2629 .....	5-46
5-32.	400 Hz static exciter and voltage regulator assembly schematic diagram, drawing no. 72-2630 .....	5-49
5-33.	Static exciter wiring harness, drawing no. 72-2628, voltage regulator wiring harness, drawing no. 72-2627, and static l xciter connection wiring diagram, drawing no. 72-2631 .....	5-50
5-34.	Static exciter and voltage regulator assembly sensing circuit bench test .....	5-54
5-35.	Static exciter and voltage regulator assembly power circuit bench test .....	5-54
5-36.	Generator assembly, exploded view .....	5-56
5-37.	Securing generator rotor to stator .....	5-58
5-38.	End bell assembly, exploded view .....	5-58
5-39.	Generator rotor and balance assembly, exploded view .....	5-60
5-40.	Lead block assembly, exploded view .....	5-61
5-41.	Generator stator assembly, exploded view .....	5-62
5-42.	50/60 Hz generator stator winding procedures .....	5-64
5-43.	400 Hz generator stator winding procedures .....	5-66
5-44.	50/60 Hz generator rewind procedures .....	5-68
5-45.	400 Hz generator rotor winding procedures .....	5-69
5-46.	Generator exciter stator winding procedures .....	5-71
5-47.	Generator exciter rotor winding procedures .....	5-73
5-48.	Interference Suppression Components .....	5-76
6-1.	Relay table assembly, exploded view .....	6-2
6-1.1	Relay table assembly, exploded view (effective on generator sets serial no. KZ00001 and up) .....	6-2.1
6-2.	Lifting frame, exploded view .....	6-3
6-3.	Skid base assembly, exploded view .....	6-5
7-1.	Overshoot and undershoot chart recording .....	7-10
8-1.	Fuel burning heater control assembly .....	8-4
8-2.	Fuel burning heater control assembly wiring diagram, drawing no. 72-2863 .....	8-5
8-3.	Fuel burning heater assembly, exploded view .....	8-6
8-4.	Coolant pump test diagram .....	8-8



LIST OF ILLUSTRATIONS (CONT)

Figure	Title	Page
8-5.	Fuel burning winterization kit wiring harness, drawing no. 72-2856 .....	8-10
8-6.	Fuel burning winterization heater control assembly to special relay assembly wiring harness, drawing no. 72-2875 .....	8-11
8-7.	Electric winterization kit heater control assembly, exploded view .....	8-14
8-8.	Transformer test points .....	8-15
8-9.	Electric winterization kit control assembly wiring harness, drawing no. 70-1233 .....	8-17
8-10.	Coolant pump and motor assembly, exploded view .....	8-19
8-11.	Electric winterization kit wiring harness, drawing no. 72-2855 .....	8-20
8-12.	Wheel mounting kit installation . . . . .	8-22
8-13.	Wheel mounting kit, exploded view .....	8-23
8-14.	Load bank control assembly, exploded view .....	8-26
8-15.	Control box assembly, wiring harness, drawing no. 72-2868 .....	8-27
8-16.	Control box assembly branched wiring harness, drawing no. 72-2828 .....	8-28
8-17.	Load bank housing, exploded view .....	8-30
8-18.	Load bank wiring harness, drawing no. 72-2823 . . . . .	8-31
8-19.	Top load bank wiring harness, drawing no. 72-2822 . . . . .	8-33
8-20.	Bottom load bank wiring harness, drawing no. 72-2825 . . . . .	8-35
8-21.	Load bank power wiring harness, drawing no. 72-2829 . . . . .	8-37
8-22.	Load bank signal wiring harness, drawing no. 72-2830 . . . . .	8-38
8-23.	Roof stiffeners, oil drain, sealing angle, isolators bottom panel tray assembly, and trailer bracket . . . . .	8-43
8-24.	Hole locations on skid base assembly . . . . .	8-44
8-25.	Mounting hardware and hole location for side panel assembly .....	8-45
8-26.	Acoustic suppression kit major components . . . . .	8-46

LIST OF TABLES

Table	Title	Page
1-1.	Fits and tolerances .....	1-8
2-1.	Tools and support equipment . . . . .	2-1
2-2.	Troubleshooting .....	2-3
3-1.	Fuel delivery .....	3-37
3-2.	Hydraulic actuator test values .....	3-60
3-3.	Undersized bearing journal dimensions . . . . .	3-76

TM 5-6115-465-34  
TO-35C2-3-446-2  
NAVFAC P-8-625-34  
TM 06858B/06859D-34

LIST OF TABLES (CONT)

Table	Title	Page
4-1.	Component board test values .....	4-12
4-2.	50/60 Hz governor control unit resistance test values .....	4-26
4-3.	400 Hz governor control unit resistance test values . . . .	4-26
5-1.	Static exciter and voltage regulator resistor and capacitor values .....	5-48
7-1.	Operating tests .....	7-3
7-2.	Engine generator set classification chart . . . . .	7-4
7-3.	Electrical performance characteristic parameters AC precise (Class 1) .....	7-5
8-1.	Fuel burning winterization kit troubleshooting chart . . .	8-1
8-2.	Electrical winterization kit troubleshooting chart .....	8-12

CHAPTER 1  
INTRODUCTION

---

SECTION I. GENERAL

1-1. Scope

a. This manual contains instructions for the use of intermediate (field) (direct and general support) and depot maintenance personnel responsible for maintaining the 30 KW Diesel Engine Generator Sets, Models MEP-005A, MEP-104A, and MEP-114A. The maintenance information provided herein is normally beyond the scope of the tools, equipment, personnel and supplies available at the operator and organizational levels. This manual must be used in conjunction with the operator and organizational manual for complete maintenance instructions for the generator sets.

NOTE

Accomplishment of actions/tasks at designated maintenance levels as directed in this manual does not apply to the Air Force. Air Force users shall accomplish maintenance at user level consistent with their capability in accordance with policies established by AFM66-1.

1-2. Forms and Records

NOTE

This manual is used by Army, Air Force, Navy, and Marine Corps personnel. Use of forms as directed in this manual will be accomplished only by personnel of that service to which such forms apply,

a. Maintenance forms and records used by Army personnel will be only those prescribed by DA Pam 738-750. Those to be used by Marine Corps personnel are prescribed in the latest edition of TM 4700-15/1, Air Force forms and records used will be those prescribed by AFM66-1 and the applicable 00-20 Series Technical Orders. Navy users should refer to their appropriate publications to determine the applicable forms and records to be used.

b. Reports of errors, omissions, and recommendations for improvement of this manual by its user is encouraged. Such reports should be submitted by various service personnel as follows:

(1) Air Force. AFTO Form 22 directly to Commander, Sacramento Air Logistics Center, SM-ALC-MMEDTA, McClellan Air Force Base, CA 95652-5609 In accordance With TO-00-5-1.

(2) Army. DA Form 2028 directly to Commander, US Army Troop Support Command, ATTN: AMSTR-MCTS, 4300 Goodfellow Blvd., St. Louis, MO 63120-1798.

(3) Marine Corps. NAVMC 10772 directly to Commanding General, U S Marine Corps, Marine Corps Logistics Base, (Code 850), Albany, GA 31704-5000.

(4) Navy. By letter directly to Commander, Naval Construction Battalion Center, ATTN: Code 15741, Port Hueneme, CA 93043-5000.

1-3. Demolition to Prevent Enemy Use

Demolition of the generator set to prevent enemy use will be in accordance with the requirements of TM 760-244-3 (Procedures for Destruction of Equipment to Prevent Enemy Use for U.S. Army and U.S. Marine Corps).

1-4. Shipment and Storage

a. Preparation for shipment and storage of the generator set for US Air Force will be in accordance with TO 35-1-4.

b. Shipment and storage for US Army and the US Marine Corps will be in accordance with TB 740-97-2.

Section II. DESCRIPTION AND DATA

1-5. Description

The generator set is a fully enclosed, self-contained, skid mounted, portable unit. It is equipped with controls, instruments, and accessories which enable it to be operated as a single unit or in parallel with two or more units of the same size, class, and mode. In addition, the generator sets will accept and operate with fuel and electric winterization kits, load bank kit, wheel mounting kit, automatic transfer panel kits and a remote control box. For a more detailed description of the generator sets, refer to the Operator's and Organizational Maintenance Manual. A more detailed description of specific components and assemblies is found in the applicable maintenance paragraphs of this manual.

1-6. Tabulated Data

a. General. This paragraph contains all maintenance data pertinent to intermediate (field) (direct and general support), and depot maintenance personnel. For additional tabulated data, refer to the Operator's and Organizational Maintenance Manual.

b. Engine Classification and Rating.

Model . . . . . D2998ERX37  
 Installation drawing. . . . . 40-A-8875  
 Bore and stroke . . . . . 33/4 x 4 1/2 inch  
 Number of cylinders . . . . . 6  
 Piston displacement (cu. in.) . . . . . 298  
 Dry weight (approx.) . . . . . 960 pounds  
 Lubricating oil capacity  
 (with filters). . . . . 8 quarts  
 Low idle recommendations . . . . . 1100 to 1200 rpm

Fuel consumption (gals/hr):

1500 rpm (50 Hz, 25 kw) . . . . . 2.35  
 1800 rpm (60Hz, 30 kw) . . . . . 2.85  
 2000 rpm (400Hz, 30 kw) . . . . . 2.90

Heat rejection to coolant (btu/min):

1500 rpm (50Hz, 25kw) . . . . . 1,407  
 1800 rpm (60Hz, 30kw) . . . . . 1,689  
 2000 rpm (400Hz, 30kw) . . . . . 1,767

Air consumption (CFM):

1500 rpm (50 Hz, 25kw) . . . . . 111.3  
 1800 rpm (60Hz, 30kw) . . . . . 134  
 2000 rpm (400 Hz, 30kw) . . . . . 149

Water pump delivery (GPM):

1500 rpm (50 Hz, 25kw) . . . . . 18  
 1800 rpm (60 Hz, 30kw) . . . . . 22  
 2000 rpm (400 Hz, 30kw) . . . . . 24.5

Crankcase:

Material. . . . . Alloy cast iron  
 How Cast . . . . . Integral with block

Crankshaft:

Material. . . . . Special steel, hardened bearing surfaces  
 Number of bearings . . . . . 5  
 Bearing diameter. . . . . 2 7/8 inches

Bearing lengths:

Front . . . . . 1 1/32 inches  
 Center. . . . . 2 1/8 inches  
 Rear . . . . . 1 1/32 inches  
 Intermediate. . . . . 1 1/32 inches

Connecting rod:

Material. . . . . Heat treated steel  
 Bearing diameter. . . . . 2 3/8 inches  
 Bearing length. . . . . 1 11/64 inches  
 Rod length (c to c) . . . . . 8 inches

Piston and piston pin:

Piston material . . . . Heat treated aluminum alloy  
 Pin material . . . . . Alloy steel  
 Pin type . . . . . Full floating

Camshaft:

Number of bearings . . . . . 4  
 Bearing diameter. . . . . 2 1/16 inches

Bearing Length:

Front . . . . . 1 1/16 inches  
 Intermediate. . . . . 13/16 inches  
 Rear . . . . . 1 1/16 inch

Cylinder head:

Material . . . . . Alloy casting  
 Type. . . . . One piece casting  
 Valve arrangement. . . . . Overhead  
 (E-I-E-I-I-E-E-I-I-E-I-E)

Valve material (intake and exhaust . . . . . High alloy forging

c. Starter Assembly Classification and Rating.  
 Stalled current . . . . . 500 amps (max)  
 Stalled torque . . . . . 18 lbs. - ft. (min)  
 Duty classification . . . . . 15 sec on - 15 sec off  
 (2 starting cycles per  
 minute)

Drive type . . . . . Positive indexing with  
 overrun clutch

d. Fuel Injector Pump Classification and  
 Rating.  
 Manufacturer . . . . . Hartford Machine Screw  
 Co., Div. of Standard  
 Screw Co., Inc.

Model . . . . . DBGFC633X1LK  
 Line pressure . . . . . 2500 to 2950 psig  
 Transfer pump pressure. . . . . 130 psig (max)  
 Transfer pump lift . . . . . 15 in. HG (min)  
 Full load rpm . . . . . 1800

Delivery variation  
 between cylinders at  
 full load . . . . . 5% (max)

e. Static Exciter and Voltage Regulator  
 Assembly Classification and Rating.

Type . . . . . Solid state  
 Voltage regulation:  
 MEP-005A . . . . . 3% of rated voltage  
 MEP-104A . . . . . 1% of rated voltage  
 MEP-114A . . . . . 1% of rated voltage

Voltage stability:  
 Short term:  
 MEP-005A . . . . . Within 2% of rated  
 voltage  
 MEP-104A . . . . . Within 1% of rated  
 voltage  
 MEP-114A . . . . . Within 1% of rated  
 voltage

Long term:  
 MEP-005A . . . . . Within 4% of rated  
 voltage  
 MEP-104A . . . . . Within 2% of rated  
 Voltage  
 MEP-114A . . . . . Within 2% of rated  
 voltage

Voltage drift (8 hour  
 period, with tempera-  
 ture variation of up  
 to 60°F)(15.5°C) . . . . . 1%

Transient performance:  
 Resumption of steady state:  
 MEP-005A . . . . . Within 3 sec.  
 MEP-104A . . . . . Within 0.5 sec.  
 MEP-114A . . . . . Within 0.5 sec.

Overshoot/undershoot:  
 MEP-005A . . . . . 20% rated voltage  
 MEP-104A . . . . . 15% rated voltage  
 MEP-114A . . . . . 12% rated voltage

f. Governor Control Unit Classification and  
 Rating.

DOD Drawing Numbers:  
 50/60 Hz . . . . . 69-784-2  
 400 HZ . . . . . 81-4903  
 Type . . . . . Solid state  
 Input volts . . . . . 24 Vdc and 120 Vac  
 Frequency regulation . . . . . 0.25%  
 Power dissipation . . . . . 115 watts (max)  
 Enclosure . . . . . Water-proof, wax-filled  
 casing

f.1 Governor Control Kit Classification and  
 Rating.

DOD Drawing numbers:  
 Governor control unit . . . . . 81-4903  
 Magnetic actuator . . . . . 81-705  
 Magnetic pickup . . . . . 81-4904  
 Type: . . . . . Solid state  
 Input volts . . . . . 11-40 Vdc  
 Frequency regulation . . . . . 0.25%  
 Temperature range . . . . . -65° to 185°F  
 (-55° to 85°C)

g. Overvoltage Relay Classification and  
 Rating.

DOD Drawing number . . . . . 72-2257  
 Nominal voltage . . . . . 120 Vac  
 Actuation voltage . . . . . 153 ± 3 Vac over fre-  
 quency range of 50 to  
 450 Hz  
 Time delay . . . . . 200 m sec sustained  
 overvoltage (rein)  
 Trip time . . . . . Less than 1.0 sec.  
 after sustained pull-  
 in voltage  
 Contact rating . . . . . 10 drop, 28.5V,  
 resistive  
 Temperature range . . . . . -65°F (-58.5°C) to  
 + 170°F (76.7°C)

h. Undervoltage Relay Classification and  
 Rating.

DOD drawing number . . . . . 70-1120  
 Nominal voltage . . . . . 120 Vac  
 Frequency range . . . . . 50 to 450 Hz  
 Drop-out voltage . . . . . 99 ± 4 Vac  
 Pull-in voltage . . . . . 110 ± 3 Vac  
 Time delay . . . . . 6 ± 2 sec. after drop-  
 it (instantaneous at  
 40 Vac and below)

TM 5-6115-465-34  
TO 35C2-3-446-2  
NAVFAC P-8-625-34  
TM 06858B/06859D-34

Contact rating . . . . . 10 amp, 28V, resistive  
Contact arrangement . . . . . 2 pole, double throw  
Temperature range . . . . . -65°F (-58.5°C) to  
+170°F (76.7°C)

Trip voltage variation  
over temperature  
range . . . . . ± 2% max.

i. Underfrequency Relay Classification and Rating.

DOD drawing number:

50/60Hz . . . . . 70-1119  
400 Hz . . . . . 70-1141

Input voltage (nominal) . . 120 Vac

Trip frequency:

400 Hz . . . . . 370 ± 5 Hz  
60 Hz . . . . . 48 ± 3 Hz  
50 Hz . . . . . 43 ± 3 Hz

Voltage input limits . . . + 10 percent

Temperature range . . . . . -65°F (-58.5°C) to  
+170°F (76.7°C)

Trip frequency  
variation over  
temperature range . . . . . ± 2 Hz

j. Short Circuit Relay Classification and Rating.

DOD drawing number . . . . . 72-2256

Trip voltage . . . . . 10 ± Vac (any phase to  
neutral)

Contact rating . . . . . 10 amp, 28 Vdc

Frequency range . . . . . 50 Hz to 450 Hz

Temperature range . . . . . -65°F (-58.5°C) to  
170°F (76.7°C)

Trip variation over  
temperature range . . . . . 5 percent maximum

k. Reverse Power Relay Classification and Rating.

DOD drawing number . . . . . 72-2255

DC input voltage . . . . . 0 to 10 Vdc

AC superimposition . . . . . Up to 20 Vac

Reverse polarity . . . . . 20 percent  
(approximate)

Temperature range . . . . . -65°F (-58.8°C) to  
170°F (76.7°C)

Variations in trip  
voltage over  
temperature range . . . . . ± 3 Vdc (max)

Contact rating . . . . . 10 amp, 28 Vdc,  
resistive

l. Permissive Paralleling Relay Classification and Rating.

DOD drawing number . . . . . 70-1118

Input power . . . . . 24 Vdc

Actuation point . . . . . 8 ± 1 Vac (falling)

Frequency range . . . . . 50 Hz to 400 Hz

Temperature range . . . . . -65°F (-58.8°C) to  
170°F (76.7°C)

Variation of actuation  
point over temperature  
range . . . . . Less than 1 Vac

Contact rating . . . . . 10 amp, 28 Vdc,  
resistive

Thermal Watt Converter Classification and Rating.

DOD drawing number:

50/60 Hz . . . . . 69-589-1  
400 HZ . . . . . 69-589-2

Operating voltage . . . . . 100 to 130 Vac

Current . . . . . 1 amp

Elements . . . . . 3

Phase . . . . . 3

Number of wires . . . . . 4

Output . . . . . 20 MVdc, open circuit

Circuit resistance  
(output) . . . . . 4.97 ohm

Watts per element:

50/60Hz . . . . . 96.26  
400 Hz . . . . . 96.3

n. Main Load Contactor Contactor Classification and Rating.

DOD drawing number . . . . . 69-680

Enclosure . . . . . Gasket sealed casing

KVA . . . . . 125 (max)

Main contact type . . . . . Double break, magnetic

Voltage range . . . . . 120 Vac to 416 Vac

Frequency range . . . . . 50 Hz to 400 Hz

Continuous current . . . . . 350 amp

Interruption current . . . 5000 amp (max)

Auxiliary contacts:

Operating voltage . . . . . 28 Vdc  
Operating current . . . . . 7.5 amp  
AC voltage . . . . . 120 Vac  
Lamp current . . . . . 7.5 amp

Operational lag  
behind main  
contacts . . . . . 0.001 to 0.003 sec.

Coil data:

Operating voltage . . . . . 18 to 30 Vdc  
Actuation time . . . . . 0.035 to 0.050 sec.  
Close coil resistance . . 8 ohm

50/60 Hz Generator Classification and Rating.

Rating . . . . . .30 KW

Kilovolt amperes:

1500 rpm (50 Hz) . . . . . 18.75  
1800 rpm (60 Hz) . . . . . 15.63

o. 50/60 Hz Generator Classification and Rating (Cont):

Winding resistances (total):  
 Winding . . . . . nominal value, in ohms,  
 at 77°F (25°C)  
 Generator field  
 (rotor) . . . . . 3.31  
 Generator armature  
 (stator) . . . . . 0.068  
 Phase . . . . . 3  
 Temperature rise . . . . . 167°F (75°C)  
 Degree of enclosure . . . . Drip-proof  
 Lubrication  
 requirements . . . . . None

p. 400 Hz Generator Classification and Rating:

Rating . . . . . 30 KW  
 Kilovolt amperes . . . . . 37.50  
 Winding resistances (total):  
 Winding . . . . . Nominal value, in ohms,  
 at 77°F (25°C)  
 Generator field  
 (rotor) . . . . . 2.61  
 Generator armature  
 (stator) . . . . . 0.033  
 Phase . . . . . 3  
 Temperature rise . . . . . 167°F (75°C)  
 Degree of enclosure . . . . Drip-proof  
 Lubrication  
 requirements . . . . . None

50/60 Hz and 400 Hz Generator Exciter Classification and Rating.

Manufacturer . . . . . Electric Machinery Mfg.  
 Co., Inc.  
 Type . . . . . Rotating armature with  
 externally mounted static  
 excitation and voltage  
 regulation assembly  
 Kilovolt amperes . . . . . 1.63  
 Winding resistances:  
 Winding . . . . . Nominal value, in ohms,  
 at 77°F (25°C)  
 Exciter field  
 (total) . . . . . 2.19  
 Exciter armature  
 (single coil) . . . . . 0.10  
 Phase . . . . . 3  
 Operating frequency:  
 50 Hz generator . . . . . 100 Hz  
 60 Hz generator . . . . . 120 Hz  
 400 Hz generator . . . . . 133 Hz

Volts . . . . . 62.5  
 Amperes . . . . . 26  
 Duty classification . . . . . Continuous  
 Field winding (stator) . . . . Series  
 Degree of enclosure . . . . . Drip-proof  
 Cooling . . . . . Convection

r. 50/60 Hz Generator Repair and Replacement standards.

Rotor:

Number of coils . . . . . 4  
 Turns per coil . . . . . 335  
 Wires per turn . . . . . 2  
 Wire size . . . . . #15 Rd.  
 Number of slots . . . . . 8  
 Coils per slot . . . . . 2  
 Turns per coil . . . . . 710  
 Coil connection . . . . . Series  
 Field volts . . . . . 53  
 Total resistance . . . . . 2.94 ohm  
 Pole length . . . . . 5.75 inches  
 Insulating materials . . . Varnish, type M Grade  
 CL155, MIL-I-24092  
 Dripping compound . . . . Varnish, fungus-  
 resistant, MIL-V-173

Stator:

Number of poles . . . . . 4  
 Number of slots . . . . . 54  
 Number of coils . . . . . 54  
 Turns per coil . . . . . 7  
 Coils per slot . . . . . 1  
 Turns per slot . . . . . 7  
 Wires per turn . . . . . 3  
 Wires per slot . . . . . 3  
 Pitch Of coils . . . . . 1 and 12  
 Grouping of coils . . . . . 12 groups of 2  
 6 groups of 5  
 Wire size . . . . . #16 Rd.  
 Gap bore . . . . . 11.0 inches  
 Skew at gap . . . . . 0.64 inches

Insulating materials:

Slot insulators . . . . . 54  
 Phase insulators . . . . . 12  
 Varnish . . . . . Type M, Grade CL155,  
 MIL-V-173.

r. 50/60 Hz Generator Repair and Replacement Standards (Cont):

Dipping compound . . . . . Varnish, fungus-resistant, MIL-V-173

s. 400 Hz Generator Repair and Replacement Standards.

Rotor:

Number of coils . . . . . 24  
Turns per coil . . . . . 56  
Wires per turn . . . . . 2  
Wire size . . . . . #10 Rd.  
Number of slots . . . . . 108  
Coils per slot . . . . . 2  
Turns per slot . . . . . 102  
Coil connection . . . . . Series  
Field volts . . . . . 53  
Total resistance . . . . . 2.61 ohms  
Pole length . . . . . 3.5 inches  
Insulating material . . . . Varnish, type M, Grade CL155, MIL-I-24092  
Dipping compound . . . . . Varnish, fungus-resistant, MIL-V-173

Stator:

Number of poles . . . . . 24  
Number of slots . . . . . 108  
Number of coils . . . . . 108  
Turns per coil . . . . . 8  
Coils per slot . . . . . 1  
Turns per slot . . . . . 8  
Wires per turn . . . . . 2  
Wires per slot . . . . . 2  
Pitch of coils . . . . . 1 and 4  
Grouping of coils . . . . . 36 groups of 1; 36 groups of 2 (1-2-1-2-1-2 repeated 12 times)  
Wire size . . . . . #16 Rd.  
Gap bore . . . . . 13.5 inches  
Skew at gap . . . . . 0.40 inches  
Insulating materials:  
Slot insulators . . . . . 108  
Phase insulators . . . . . 12  
Varnish . . . . . Type M, Grade CL155, MIL-I-24092  
Dipping compound . . . . . Varnish, fungus-resistant, MIL-V-173

t. 50/60 Hz and 400 Hz Generation Exciter Repair and Replacement Standards.

Rotor :

Number of coils . . . . . 4  
Turns per coil . . . . . 200  
Wires per turn . . . . . 1  
Wire size . . . . . #15 Rd.  
Number of Slots . . . . . 8  
Coils per slot . . . . . 1  
Turns per slot . . . . . 200  
Coil connection . . . . . Series  
Field volts . . . . . 62.5  
Total resistance . . . . . 2.19 ohms  
Pole length . . . . . 1.6 inches  
Rotor diameter . . . . . 7.42 inches  
Insulating material . . . . Varnish, type M, Grade CL155, MIL-I-24092  
Dipping compound . . . . . Varnish, fungus-resistant, MIL-V-173

Stator:

Number of poles . . . . . 8  
Number of slots . . . . . 24  
Number of coils . . . . . 8  
Turns per coil . . . . . 8  
Coils per slot . . . . . 1  
Turns per slot . . . . . 8  
Wires per turn . . . . . 3  
Wires per slot . . . . . 3  
Pitch of coils . . . . . 1 and 3  
Grouping of coils . . . . . 24 groups of 1 (1 group repeated 24 times)  
Wire size . . . . . #18 Rd.  
Gap bore . . . . . 7.5 inches  
Skew at gap . . . . . 0  
Insulating materials:  
slot insulators . . . . . 24  
Phase insulators . . . . . 12  
Varnish . . . . . Type M, Grade CL155, MIL-I-24092  
Dipping compound . . . . . Varnish, fungus resistant, MIL-V-173

u. Engine Repair and Replacement Standards. Table 1-1 lists manufacturer's sizes, maximum allowable wear, and maximum allowable clearances for the engine assembly.



**v. Nut and Bolt Torque Data.**

Engine:

Cylinder head nuts: .....	
9/16 dia. studs .....	160 ft-lb
5/8 dia. stud .....	175 ft-lb
Nozzle holder attaching screw .....	23 ft-lb
Connecting rod bolt .....	70 ft-lb
Main bearing cap bolt: .....	
9/16 inch .....	130 ft-lb
1/2 inch .....	100 ft-lb
Camshaft gear nut .....	130 ft-lb
Flywheel bolts .....	80 ft-lb
Manifold attaching .....	
nut .....	18-20 ft-lb
Fuel pump gear .....	60-65 ft-lb
nut .....	
Crankshaft pulley nut .....	125 ft-lb
Bellhousing screw .....	75 ft-lb
Idler shaft screw .....	24-27 ft-lb
Oil pan bolts .....	21 ft-lb
Fuel injection pump:	
Fuel injection .....	
mounting screw .....	30-40 ft-lb
End plate capscrew .....	30 in-lb
Body plugs (side) .....	215-265 in-lb
Body plug (bottom) .....	40-50 in-lb
Connector screw .....	420 in-lb
Cam advance screw .....	400 in-lb
Cap and filter assy .....	240 in-lb
Guide stud .....	115 in-lb
Cover hold down	
screw .....	40 in-lb
Shutoff lever	
retaining screw .....	30 in-lb
Pivot shaft	
retainer nut, .....	25 in-lb
Torque screw nut .....	25 in-lb
Timing line cover screw .....	20 in-lb
Head locating screw .....	300 in-lb
Head locking screws .....	175 in-lb
Cam locking screw .....	500 in-lb
End plate plug .....	60 in-lb
End plate pipe plug .....	360 in-lb
Fuel pump to	
drive gear nut .....	35-40 ft-lb

Generators

Lockplate attaching	
screw .....	120 ft-lb
Main rotor diode .....	30 ft-lb
Stator mounting screw .....	17 ft-lb
Rotor mounting screw .....	17 ft-lb
Balance weight	
attaching screw .....	31 ft-lb
Exciter stator	
mounting screw .....	17 ft-lb
Exciter rotor	
mounting screw .....	17 ft-lb
Exciter rotor	
diode .....	28 in-lb
Exciter rotor to rotor	
shaft .....	60 in-lb
Rectifiers .....	28 in-lb
Blower assembly to	
screws .....	75 ft-lb
End bell assembly	
to stator .....	31 ft-lb
Bearing housing	
screws .....	31 ft-lb
Bearing adapter .....	88 ft-lb
Mounting screws	
(and nuts) .....	200-220 ft-lbs

w. Wiring Diagrams and Schematic  
 Diagrams. Refer to the Operator and  
 Organizational Maintenance Manual for  
 the Generator Set wiring diagrams and  
 schematic diagrams.

Table 1-1. FITS AND TOLERANCES

Component	Mfg's Tolerances		Desired Clearance		Maximum Allowable Wear	Maximum Allowable Clearance
	Minimum	Maximum	Minimum	Maximum		
<b>CYLINDER BLOCK:</b>						
Cylinder bore dia.	3.7490	3.7510		0.0050		
Cylinder bore dia (Bohn)	3.7505	3.7515				
Cylinder bore out of round		0.0005		0.0030		
Cylinder bore taper		0.0005		0.0020		
Main brg. bore-less brgs.	3.0005	3.0870				
Camshaft brg. bore-less brgs.	2.1870	2.1880				
Oil pump bore	2.0000	2.0005				
Valve tappet bore	0.748	0.7500				
Warpage		0.0003				
Milling		0.00(-)5				
<b>CRANKSHAFT:</b>						
Main brg. journal dia.	2.8734	2.8744		0.0030		
Main brg. journal out of round		0.0003		0.0020		
Main brg. journal taper		0.0003		0.0015		
Main brg. run-out at center		0.0020		(.)0030		
Corm. rod journal dia.	2.3730	2.3740		0.0020		
Corm. rod journal out of round		0.0003		0.0020		
Corm. rod journal taper		0.0003		0.0015		
Fillet radii	0.1400	0.1700				
Crankshaft main brg. clearance			0.0009	0.0034		0.0070
Crankshaft thrust clearance			0.0050	0.0100		0.0150
Seal surface dia. - rear	4.3100	4.3150			0.0150	
Seal surface dia. - front	1.8740	1.8750			0.0150	
<b>CONNECTING ROD:</b>						
Length - c to c	7.9980	8.0020				
Baring bore-less bearings	2.5260	2.5270				
Br. to crankshaft clearance			0.0010	0.0030		0.0050
Corm rod side clearance			0.0050	0.0120		0.0200
Piston pin bushing bore	1.2503	1.2508			0.0015	
Piston pin bushing bore-Icss bushing	1.4370	1.4380				
<b>CAMSHAFT:</b>						
Bearing journal dia.	2.0530	2.0540			0.0020	
Lobe diameter - base to tip	1.6890	1.7250			0.0100	
Journal run-out in vee blocks		0.0010			0.0040	
Bearing clearance			0.0015	0.0035		0.0060
End thrust			0.0015	0.0055		0.0120
Back lash camshaft to crank gear			0.001	0.003		
<b>PISTON:</b>						
Clearance in cyl. bore (pull on 1/2x0.0050 ribbon)	5 lb.	8 lb.				
Clearance in cyl. bore (pull on 1/2 x .005 ribbon (Bohn))	3.7445	3.7455				
Piston pin bore	1.2500	1.2502			0.0010	
Width of ring groove - top - Keystone	1/8 nom.					
Width of ring groove - 2nd & 3rd comp.	0.0975	0.0990			0.0050	
Width of ring groove - top -oil control	0.1880	0.1895			0.0050	
Width of ring groove - lower oil control	0.1880	0.1890			0.0050	
<b>PISTON PIN:</b>						
Length	3.0350	3.0400				
Diameter	1.2498	1.2499			0.0020	
Clearance in piston			0.0000	0.0005		0.0020
Clearance in connecting rod			0.0005	0.0012		0.0050

Table 1-1. FITS AND TOLERANCES (CONT)

Component	Mfg's Tolerances		Desired Clearance		Maximum Allowable Wear	Maximum Allowable Clearance
	Minimum	Maximum	Minimum	Maximum		
PISTON RING: Clearance in groove - top Clearance in groove - 2nd & 3rd comp. Clearance in groove - oil control Gap	Keystone 0.0040 0.0015 0.0100	Taper 0.0060 0.0030 0.0200				0.0080 0.0080 0.0400
VALVE, INTAKE: Head diameter Stem diameter Stem to guide clearance Stem to rocker arm clearance-hot Seat diameter in head Seat width in head Top of valve recessed below cyl. hd deck Valve seat angle	1.6825 0.3725   1.6470  0.0210 30°	1.6925 0.3735   1.6530 7/64   	0.0005 0.0150	0.0025	0.0025   1/8	0.0050
VALVE, EXHAUST: Head diameter Stem diameter Stem to guide clearance Stem to rocker arm clearance-hot Seat diameter in head Seat width in head Top of valve recessed below cyl. hd deck Valve seat angle	1.4950 0.3725   1.4510  0.0210 45°	1.5050 0.3732   1.4560 7/64   	0.0015 0.0150	0.0035	0.0025   1/8	0.0060
VALVE GUIDE: Length Outside diameter Bore diameter - intake - ream Bore diameter - exhaust - ream Depth below cyl. head deck	2.0325 0.6265 0.3740 0.3750 1.3700	2,9524 0.6270 0.3750 0.3760 1.3800			0.0030 0.0030	
TAPPET. VALVE LIFTER (PUSH ROD): Body diameter Overall length Clearance in bore (block)	0.7485 2.2450	0.7490 2.2550	0.0005	0.0015	0.0030	0.0050
VALVE SPRINGS - INTAKE & EXHAUST: Free length Total coils Diameter wire Outside diameter Test load at 1.4920 inches (lbs) Test load at 1.0820 inches (lbs)	1.7960 6-1/4 0.1770 1.2920 72 163	1.8360   1.3020 82 180				

Table 1-1. FITS AND TOLERANCES (CONT)

Component	Mfg's Tolerances		Desired	Clearance	Maximum Allowable Wear	Maximum Allowable Clearance
	Minimum	Maximum	Minimum	Maximum		
OIL PUMP BODY: Shaft bore diameter - main Shaft bore diameter - idler Pump gear bore diameter Pump gear bore depth Mounting flange & top of drive flange	0.6255 0.6255 1.5005 1.5640	0.6265 0.6265 1.5015 1.5650	4.83375	4.85373	0.0030 0.0030 0.0050 0.0040 0.010	
SHAFTS: Length - main Length - idler Diameter - main Diameter - idler Shaft clearance In body	9.2400 2.7450 0.6240 0.6240	9.2500 2.7550 0.6245 0.6245	0.0010	0.0025	0.0020 0.0020 0.0030	0.0060
GEARS: Outside diameter - 15th Length-both Clearance in body bore End clearance to body Backlash, drive gear to cam-shaft	1.4975 1.5610	1.4985 1.5620	0.0020 0.0020 0.0060	0.0040 0.0040 0.0120	0.0020	0.0070 0.0080 0.0200
FLYWHEEL: Clutch face run out at 6 in. rad. Pilot bore eccentricity		0.0080 0.0050				
FLYWHEEL HOUSING: Clutch attaching face deviation Clutch housing bore eccentricity		0.0080 0.0050				
ROCKER ARM MECHANISM: Rocker shaft length-6 cyl. Rocker shaft diameter Rocker arm bore diameter Rocker arm clearance on shaft Tappet adjusting screw torque ft-lbs	13.7400 0.8590 0.8625 3	13.7600 0.8600 0.8635 10	0.0025	0.0045	0.0030 0.0030	0.0120
STARTER: Commutator diameter	1.6470					
FUEL PUMP: Throttle shaft and linkage hook Impeller to cover plete	0.210	0.225	0.217 0.010			
CYLINDER HEAD: Warpage (longitudinally) Warpage (laterally)					0.005 0.003	
GENERATOR ASSEMBLIES: Bearing housing, ID Bearing adapter, OD			3.19492 1.3780	3.19502 1.3784		
FUEL BURNING WINTERIZATION KIT: Heater assembly, metering orifice pin hole diameter Adapter face (parallel) Adapter bore diameter			0.012 0.315	0.012 0.318	0.001	

**Table 1-1. FITS AND TOLERANCES (CONT)**

Component	Mfg's. Tolerances		Desired Clearance		Maximum Allowable Wear	Maximum Allowable Clearance
	Minimum	Maximum	Minimum	Maximum		
FUEL BURNING WINTERIZATION KIT: (CONT) Adapter face (parallel with rotor side of adapter ) Pump, cam ring to rotor clearance			0.002		0.001	
FUEL PUMP: Roller to roller dimension Transfer pump blades (determine wear by measuring length)	1.9635	1.9645	0.538			
MAIN BEARING: Clearance			0.0009	0.0034		



CHAPTER 2

GENERAL MAINTENANCE INSTRUCTIONS

Section I. REPAIR PARTS, SPECIAL TOOLS, AND EQUIPMENT

2-1. TOOLS AND SUPPORT EQUIPMENT.

There are no special tools or support equipment required to perform any level of maintenance on generator set Models MEP-005A, MEP-104A, and MEP-114A. Table 2-1 contains a list of recommended tools and support equipment normally required to maintain the generator sets at the intermediate (field) (direct and general support) and depot maintenance levels. References or illustrations indicating the need **or** use of these or similar tools-are as listed in the table.

2-2. DIRECT SUPPORT, GENERAL SUPPORT AND DEPOT MAINTENANCE REPAIR PARTS.

Direct support, general support and depot maintenance repair parts are listed and illustrated in the Organizational, Intermediate (Field) (Direct and General Support) and Depot Maintenance Repair Parts and Special Tools List).

2-3. FABRICATED TOOLS AND EQUIPMENT.

A breakout cable is required to troubleshoot the electric governor system of MEP-114A. The breakout cable-is used to gain access to the Governor Control Unit's MS3106R20-29 connector. Figure 2-0 gives fabrication instructions for the breakout cable.

Table 2-1. TOOLS AND SUPPORT EQUIPMENT

Item	FSN or Part No.	Reference		Use
		Figure	Para.	
Torch outfit, cutting and welding (Tool Set L/W67706)	3433-357-6311 or equal		6-2	Removing extensively damaged housing components
Oscilloscope	6625-643-1740 or equal		5-13	Testing voltage regulators
Hoist, chain, 3 ton	3950-292-9879 or equal	2-1	2-6,	Removing and Installing engine and generator assemblies
Trestle, host, portable, 5 ton	3950-449-7005 or equal	2-1,2-2	2-6, 2-7	Removing and installing engine and generator assemblies
Multimeter, spilt core	6625-892-1497 or equal		5-16	Testing resistance of generator assembly windings
Mutimeter, digital	6625-00-495-3513		4-7.1	Troubleshooting the electric governor MEP 114A only
Ohmmeter	6625-581-2466 or equal		5-16	Testing continuity of generator assembly components
Puller attachment (component of puller kit 5180-701-8046)	5180-711-6753 or equal		5-16,	Removing generator bearing.
Solder outfit, electric	3439-853-8760 or equal		5-16	Soldering electrical leads to generator assembly rectifiers
Test stand, actuator	4940-152-2107 or equal		3-42	Testing performance of hydraulic actuator
Test gauge and hose assy	4910-774-9343 or equal		3-40	Testing hydraulic pump assembly
Tachometer, stroboscopic	6680-892-1510 or equal		3-6	Testing speed switch elements trip speed
Test stand, ignition magneto	4910-912-3960 or equal		3-6	Testing of speed switch

Table 2-1. TOOLS AND SUPPORT EQUIPMENT (CONT)

Item	FSN or Part No.	Reference		Use
		Figure	Para .	
Gauge, thickness	5210-221-1999 or equal		5-6	Adjusting main load contactor
Test set, armature	6625-233-1459 or equal		3-4	Testing starter assembly armature
Tool kit, diesel injector repair	4910-317-8265 or equal		3-21	Repair of fuel Injection nozzle holder
Winding kit, valve seat	4910-473-6437 or equal		3-53	Regrinding cylinder head assembly valve seats
Wrench, torque	5120-542-5577 or equal		3-53	Tightening cylinder head nuts
Grinding machine, valve face	4910-540-4679 or equal		3-53	Refacing valves
Lifter, valve spring	5120-239-8686 or equal		3-53	Remove and installing valve springs
Remover and replacer valve guide	5120-219-8404 or equal		3-53	Removing and installing valve guides
Caliper, micrometer, outside, 1 inch to 2 inch	5210-243-2933 or equal		3-55 3-54	Checking piston pins, camshaft, and crankshaft for wear
Indicator, connecting rod alignment	4910-733-2487 or equal		3-56	Checking connecting rod alignment
Wrench, torque	5120-640-6364 or equal		3-55	Tightening connecting rod bears cap screws
Gauge set, telescoping	5210-473-9350 or equal		3-56	Checking taper and out-of-roundness of cylinder bores
Gauge, thickness	5210-517-8097 or equal		3-55	Checking thickness of piston rings
Compressor, piston ring	5120-894-0753 or equal		3-56	Installing piston into cylinder bores
Expander, piston ring	5120-393-0549 or equal		3-56	Installing rings on pistons



Table 2-1. TOOLS AND SUPPORT EQUIPMENT (CONT)

Item	FSN or Part No.	Reference		Use
		Figure	Para	
Caliper, micrometer	5210-255-7364 or equal		3-56	Checking main bearings for wear
Caliper, micrometer	5210-221-1934 or equal		3-56	Checking crankshaft main bearing journals for wear
Wrench, torque, 0-150 in-lb	5120-542-4489 or equal		3-20	Maintenance of fuel injection pump
Wrench, torque, 100-700 in-lb	5120-821-3441 or equal		3-20	Maintenance of fuel injection
Dial Indicator			3-20	Checking of fuel injection pump
Oven			5-16	Used for rotor and stator disassembly
Ring groove tool			3-55	Used for cleaning piston ring grooves
Shop equipment, electrical	4940-294-9517 or equal		8-24	Used to install acoustic suppression kit
Installation tool, hex, 5/16 inch	4940-268		8-24	Used to install acoustic suppression kit
Sling, lifting	1670-622-3632 or equal		8-24	Used to install acoustic suppression kit
Strap, lifting	4940-407		8-24	Used to install acoustic suppression kit

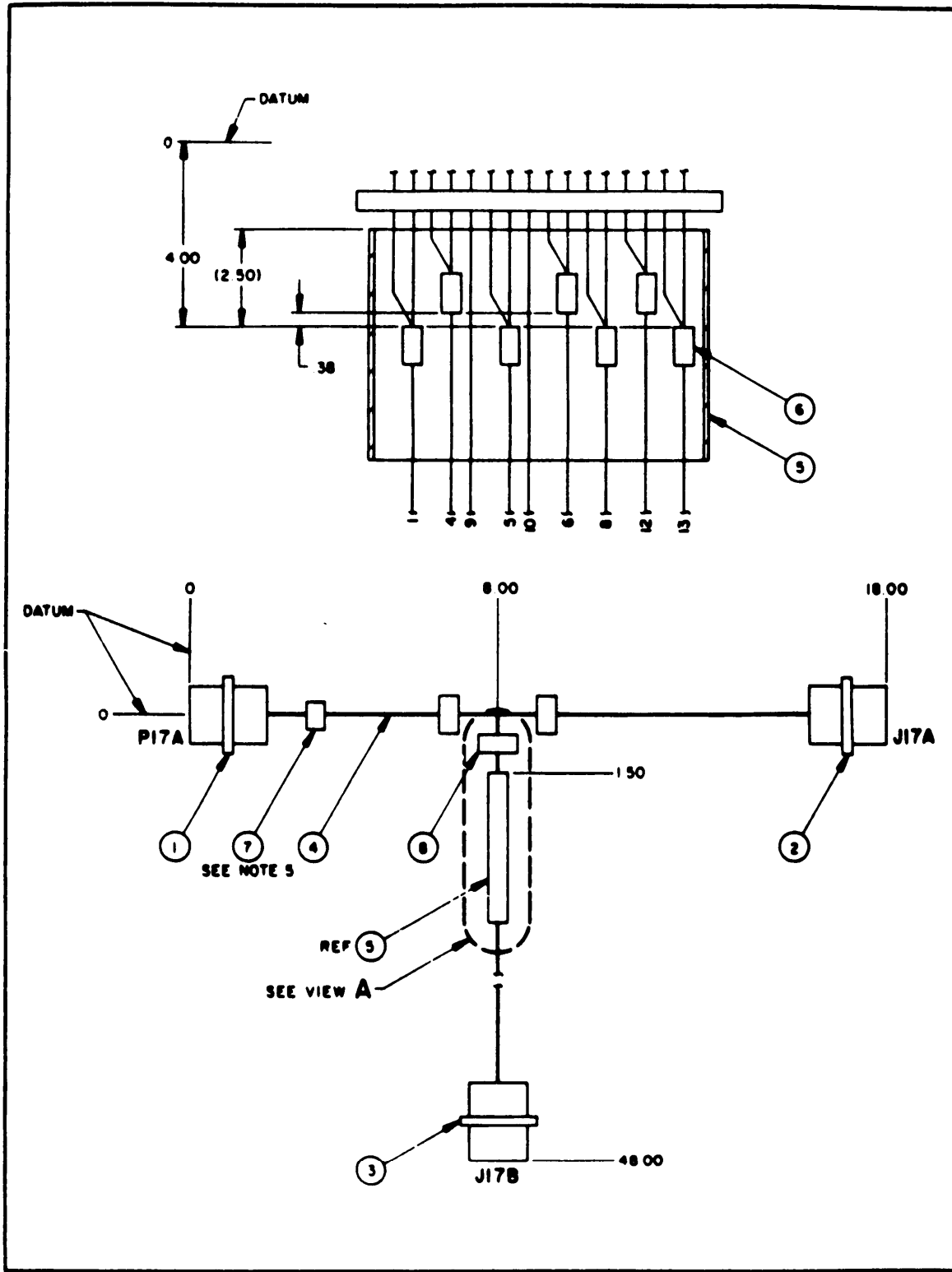

Figure 2-0. Breakout Cable (Sheet 1 of 2)

NOTES:

1. ALL CONDUCTORS SHALL BE STRIPPED .50 ±.12 AND TINNED BEFORE ASSEMBLY USING SOLDER. FIND NO. 11.
2. SOLDER IN ACCORDANCE WITH MIL-STD-454, REQUIREMENT 9, USING SOLDER. FIND NO. 11.
3. TIEDOWN STRAPS, FIND NO. 8, SHALL BE LOCATED APPROXIMATELY 3 00 APART AND AT ALL BREAKOUTS
4. CONNECTORS, FIND NO. 1, 2 AND 3 SHALL BE RUBBER STAMPED OR STENCILED WITH REFERENCE DESIGNATIONS, IN .25 HIGH, UPPER CASE GOTHIC STYLE CHARACTERS. PERMANENCY AND LEGIBILITY SHALL BE IN ACCORDANCE WITH MIL-STD-130.
5. STEEL STAMP BAND MARKER, FIND NO. 7, WITH PART NO. "30954-83-2036" IN ACCORDANCE WITH MIL-STD-130.
6. ALL UNUSED CONNECTIONS IN CONNECTORS, FIND NO. 1, 2 AND 3 SHALL BE SEALED USING PLUG, FIND NO. 10.
7. EACH WIRE SHALL BE MARKED AT 6 INCH INTERVALS WITH THE APPROPRIATE PIN LETTER IN ACCORDANCE WITH MIL-STD-130.
8. IN LIEU OF USING TERMINAL SPLICES, FIND NO. 6, WIRES MAY BE TWISTED TOGETHER AND SOLDERED AT THREE WIRE SPLICES AND COVERED WITH HEAT SHRINKABLE TUBING, FIND NO. 5.

WIRE NO.	TERMINATION		TERMINATION	
	FROM	FIND NO.	TO	FIND NO.
1	P17A-B	1	J17A-B	2
	P17A-B	1	J17B-B	3
2	P17A-C	1	J17A-C	2
3	P17A-D	1	J17A-D	2
4	P17A-F	1	J17A-F	2
	P17A-F	1	J17B-F	3
5	P17A-G	1	J17A-G	2
	P17A-G	1	J17B-G	3
6	P17A-H	1	J17A-H	2
	P17A-H	1	J17B-H	3
7	P17A-J	1	J17A-J	2
8	P17A-K	1	J17A-K	2
	P17A-K	1	J17B-K	3
9	P17A-L	1	J17B-L	3
10	P17A-M	1	J17B-M	3
11	P17A-R	1	J17A-R	2
12	P17A-S	1	J17A-S	2
	P17A-S	1	J17B-S	3
13	P17A-T	1	J17A-T	2
	P17A-T	1	J17B-T	3

11			SM60WRP2	AR	SOLDER		(Q-S-571)	
10			MS20251-10	10	PLUG, END SEAL ELECTRIC CONNLCTOP			
9			M23053/7-104-0	AR	INSULATION SLEEVING, ELEC HEAT-SHRINKABLE 125 10		MIL-I-23053/7	
8			MS3367-5-0	AR	STRAP, TIEDOWN ELECTRICAL			
7			MN3436/1-3	1	BAND MARKER, CRIMP STYLE		MIL-B-43436/1	
6			M7920/5-4	7	TERMINAL, SPLICE		MIL-T-7920/5	
5			M23053/7-100-0	1	INSULATION SLEEVING, ELEC HEAT-SHRINKABLE 6 00 L 75 10		MIL-I-23053/7	
4			MS000/2-10-0	AR	WIRE, ELECTRICAL, 16 AWG, COLOR WHT		MIL-B-5000/2	
3			MS3101R20-205	1	CONNECTOR, ELECTRICAL			
2			MS3101R20-20P	1	CONNECTOR, ELECTRICAL			
1			MS3106R20-205	1	CONNECTOR, ELECTRICAL			
FIND NO	FSM	QWG SIZE	PART OR IDENTIFYING NO	QTY REQD	NOMENCLATURE OR DESCRIPTION	SPECIFICATION	MATERIAL	

Figure 2-0. Breakout Cable (Sheet 2 of 2)



Section II. TROUBLESHOOTING

2-4. GENERAL .

This section provides information useful in diagnosing and correcting unsatisfactory operation or failure of the generator sets and their components. Malfunctions which may occur are listed in table 2-2. Each malfunction is followed by an alphabetical listing of probable causes. The corresponding alphabetical listing

of corrective actions contains references to applicable maintenance paragraphs for correction in the malfunction.

NOTE

Refer to the Operator and Organizational Maintenance Manual for troubleshooting information applicable to lower levels of maintenance.

Table 2-2. TROUBLESHOOTING

MALFUNCTION	PROBABLE CAUSE	CORRECTIVE ACTION
1. Engine fails to crank	a. Defective cranking relay K3 (34, figure 5-19). b. Defective reverse polarity diode (CR3) (see figure 5-21). c. Defective starter solenoid (7, figure 3-1). d. Defective starter motor (figure 3-1). e. Defective starter drive assembly (figure 3-1).	a. Replace defective cranking relay (para. 5-11b.). b. Replace reverse polarity diode (para. 5-11b.). c. Repair or replace starter solenoid (para. 3-4). d. Repair or replace starter assembly (para. 3-4). e. Repair or replace starter drive assembly (para. 3-4).
2. Engine cranks, but fails to start	a. Defective fuel nozzle assembly (figure 3-23). b. Defective speed switch (figure 3-14). c. Defective fuel injection pump (figure 3-19). d. Governor actuator improperly positioned.	a. Clean, adjust, repair, or replace fuel nozzle assembly (para. 3-21). b. Repair or replace speed switch (para. 3-6). c. Repair or replace fuel injection pump (para. 3-20). d. Check governor (para. 4-7, MEP 104A, or 4-7.1, MEP 114A).
3. Engine cranks, but stops when START-RUN-STOP switch is released	a. Defective relay (K1). b. Defective relay (K2). c. Defective relay (K8).  NOTE See Dc schematic diagram on left engine cover door for location of relays.	a. Replace relay K1 (para. 4-2). b. Replace relay K2 (para. 5-10). c. Replace relay K8 (para. 5-11).
4. Engine misses or runs erratically	a. Dirty or defective fuel injection nozzle holder (figure 3-23). b. Fuel injection pump out of time or defective (figure 3-19).	a. Clean, repair or replace fuel injection nozzle holders (para. 3-21). b. Correct timing, repair, or replace fuel injection pump (para. 3-20).

Table 2-2. TROUBLESHOOTING (CONT)

MALFUNCTION	PROBABLE CAUSE	CORRECTIVE ACTION
4. Engine misses or runs erratically (Cont)	<p>c. Burned or sticking valves (28 and 29, figure 3-44).</p> <p>d. Defective head gasket (n, figure 3-44).</p> <p>e. Improper governor adjustment.</p>	<p>c. Repair or replace valves (para. 3-53).</p> <p>d. Replace head gasket (para. 3-53).</p> <p>e. Adjust governor (para. 4-7), MEP 104A, or 4-7.19 MEP114A).</p>
5. Engine stops suddenly	<p>a. Defective fuel injection pump (figure 3-19).</p> <p>b. Defective speed switch (figure 3-14).</p> <p>c. Defective protective relay assembly (24, figure 5-19).</p>	<p>a. Repair or replace fuel injection pump (para. 3-20).</p> <p>b. Repair or replace speed switch (para. 3-6).</p> <p>c. Test and replace relay assembly (para. 5-11).</p>
6. Engine lacks power	<p>a. Defective fuel injection pump (figure 3-19).</p> <p>b. Dirty or defective fuel injection nozzles (figure 3-23).</p> <p>c. Burned or sticking valves (28 and 29, figure 3-44).</p> <p>d. Weak or broken valve springs (26 and 27, figure 3-44).</p> <p>e. Worn or broken piston rings (20, figure 3-50).</p> <p>f. Actuator unit defective or out of adjustment (figure 3-35, MEP 104A, or 4-30.4, MEP 114A).</p> <p>g. Defective hydraulic pump (figure 3-33).</p> <p>h. Defective cylinder head gasket (11, figure 3-44).</p> <p>i. Improper governor adjustment.</p>	<p>a. Repair or replace fuel injection pump (para. 3-20).</p> <p>b. Clean, repair or replace fuel injection nozzles (para. 3-21).</p> <p>c. Repair or replace valves (para. 3-52).</p> <p>d. Replace valve springs (para. 3-53).</p> <p>e. Replace piston rings (para. 3-55).</p> <p>f. Adjust or repair hydraulic actuator unit (para. 3-42 or electric actuator (para. 4-7.2).</p> <p>g. Test and repair hydraulic pump (para. 3-40).</p> <p>h. Replace defective cylinder head gasket (para. 3-53).</p> <p>i. Adjust governor (para. 4-7, MEP 104A, or 4-7.1, MEP 114A).</p>
7. Engine will not idle smoothly	<p>a. Burned or sticking valves (28 and 29, figure 3-44).</p> <p>b. Weak or broken valve springs (26 and 27, figure 3-44).</p> <p>c. Fuel injection nozzles out of adjustment, dirty or defective (figure 3-23).</p> <p>d. Defective camshaft (figure 3-48).</p> <p>e. Fuel injection pump defective or out of time (figure 3-19).</p>	<p>a. Repair or replace valves (para. 3-53).</p> <p>b. Replace valve springs (para. 3-53).</p> <p>c. Clean, adjust, or replace fuel injection nozzles (para. 3-21).</p> <p>d. Replace camshaft (para. 3-54).</p> <p>e. Adjust, repair, or replace fuel injection pump (para. 3-20).</p>

Table 2-2. TROUBLESHOOTING (CONT)

MALFUNCTION	PROBABLE CAUSE	CORRECTIVE ACTION
8. Engine over-heats	a. Defective shutter control or linkage (figure 3-24). b. Defective water pump assembly (figure 3-26). c. Clogged or defective radiator. d. Oil pump defective.	a. Replace shutter control linkage (para. 3-28). b. Repair or replace water pump assembly (para. 3-30). c. Clean, repair, or replace radiator (para. 3-27). d. Repair or replace oil pump (para. 3-38).
9. Engine 'knocks"	a. Fuel injection nozzle sticking (figure 3-23). b. Fuel injection pump timing advanced (figure 3-19). c. Main bearings worn (figure 3-50). d. Connecting rod bearings or wrist pins worn (figure 3-50). e. Worn. timing gear train (figure 3-42). f. Loose flywheel (figure 3-40). g. Loose generator coupling. h. Incorrect valve adjustment.	a. Clean, repair, or replace fuel injection nozzles (para. 3-21). b. Adjust fuel injection pump timing (para. 3-20). c. Replace main bearings (para. 3-55). d. Replace connecting rod bearings or wrist pins (para. 3-55). e. Replace timing gears (para. 3-50). f. Tighten flywheel mounting hardware (para. 3-50). g. Tighten generator coupling (para. 2-6). h.. Check valve adjustment. (Operator and Organizational Maintenance Manual.)
10. Engine exhaust smoke excessive	a. Fuel injection nozzle holders out of adjustment, dirty or defective (figure 3-23). b. Worn, broken, or stuck piston rings (20, figure 3-50). c. Worn valve guides or seals (figure 3-44). d. Burned valves (figure 3-44). e. Defective head gasket (11, figure 3-44).	a. Clean, adjust, or replace fuel injection nozzles (para. 3-21). b. Replace piston rings (para. 3-55). c. Replace valve guides and seals (para. 3-53). d. Replace or repair burned valves (para. 3-53). e. Replace defective head gasket (para. 3-53).
11. Engine oil consumption excessive	a. Leaking seals (figure 3-41). b. Sticking, dirty, or defective oil pump pressure relief valve (4, figure 3-30).	a. Check crankshaft seals in timing gear cover. Check bell housing for dripping oil. Replace seals as necessary (para. 3-49, 3-50). b. Clean, repair or replace oil pump pressure relief valve (para. 3-36).

Table 2-2. TROUBLESHOOTING (CONT)

MALFUNCTION	PROBABLE CAUSE	CORRECTIVE ACTION
11. Engine oil consumption excessive (Cent)	<ul style="list-style-type: none"> <li>c. Worn, broken, or stuck piston rings (20, figure 3-50).</li> <li>d. Worn valve guides, valve stems, or valve stem seals (figure 3-44).</li> <li>e. Oil return passages clogged (figure 3-51).</li> </ul>	<ul style="list-style-type: none"> <li>c. Replace piston rings (para. 3- 55).</li> <li>d. Replace valve guides, valves, and seals (para. 3- 53).</li> <li>e. Clean oil return passages (para. 3- 56).</li> </ul>
12. Engine oil pressure low	<ul style="list-style-type: none"> <li>a. Dirty, sticking, or defective oil pump pressure relief valve (4, figure 3- 30).</li> <li>b. Main bearings worn (figure 3-50).</li> <li>c. Defective oil pump (figure 3-30).</li> <li>d. Worn camshaft bearings (figure 3- 51).</li> </ul>	<ul style="list-style-type: none"> <li>a. Clean, repair, or replace defective oil pump pressure relief valve (para. 3-38).</li> <li>b. Replace main bearings (para. 3-55)</li> <li>c. Repair or replace oil pump (para. 3-38).</li> <li>d. Replace camshaft bearings (para. 3-54).</li> </ul>
13. Battery charging ammeter shows no charge when batteries are low	<ul style="list-style-type: none"> <li>a. Battery charging alternator voltage regulator out of adjustment or defective.</li> <li>b. Defective alternator rotor (figure 3-4).</li> <li>c* Worn alternator brushes (figure 3-4).</li> <li>d. Defective diode rectifier assembly (figure 3-4).</li> </ul>	<ul style="list-style-type: none"> <li>a. Adjust or replace battery charging alternator voltage regulator and cover assembly (para. 3-5).</li> <li>b. Repair or replace alternator rotor (para. 3-5).</li> <li>c. Replace alternator brushes (para. 3-5).</li> <li>d. Replace diode rectifier and plate assembly.</li> </ul>
14. Generator fails to build up rated voltage or voltage goes to "0" when START-RUN-STOP switch is released.	Defective voltage regulator assembly (figure 5-30).	Test and repair regulator (para. 5- 13)
14. No voltage observed during acceleration.	Field flash circuit.	Perform static check of field flash circuit. Refer to Operator/Organizational Maintenance Manual for generator set schematic and wiring diagrams (para 5-16.1).
15. Generator no-load terminal voltage too low or too high	Defective voltage regulator (figure 5-30).	Test and repair voltage regulator (para. 5-13).
16. Generator terminal voltage unstable	Defective voltage regulator (figure 5-30).	Test and repair voltage regulator (para. 5-13).
17. Main load contactor fails to close	<ul style="list-style-type: none"> <li>a. Defective contactor switch S3.</li> <li>b. Defective main load contactor (figure 5-2).</li> </ul>	<ul style="list-style-type: none"> <li>a. Check switch S3. Replace if defective.</li> <li>b. Repair or replace main load contactor (para. 5-6).</li> </ul>



Table 2-2. TROUBLESHOOTING (CONT)

MALFUNCTION	PROBABLE CAUSE	CORRECTIVE ACTION
17. Main load contactor fails to close (Cent)	c. Defective short circuit relay K13. d. Defective overload reload relay K14. e. Defective reverse power relay K15. f. Defective undervoltage relay K11 (Precise Sets Only). g. Defective under-frequency relay K12. h. Defective permissive paralleling relay K16.  NOTE  See DC schematic diagram on left engine cover door for location of relays.	c. Check relay K13. Replace if defective (para. 5-10). d. Check relay K14. Replace if defective (para. 5-10), e. Check relay K15. Replace if defective (para. 5-10). f. Check relay K11. Replace if defective (para. 5-12). g. Check relay K12. Replace if defective (para. 5-12). h. Check relay K16. Replace if defective (para. 5-12).



Table 2-2. TROUBLESHOOTING (CONT)

MALFUNCTION	PROABABLE CAUSE	CORRECTIVE ACTION
18. Generator terminal voltage drops when load is applied	a. Defective voltage regulator assembly ( figure 5-30). b. Loose electrical connection ( figure 5-30).	a. Repair voltage regulator assembly (para. 5-13). b. Check and tighten electrical connection.
19. Poor voltage, regulation	a. operations switch set to parallel operation. b. Defective voltage regulator ( figure 5-30). c. Defective current transformer CT4, CT5, or CT6 (4, figure 5-9).	a. Place operations switch to single unit position (para. 4-2). b. Repair voltage regulator assembly (para. 5-13). c. Replace current transformer assembly (para. 5-8).
20. Generators do not parallel properly	a. Governor control unit defective or out of adjustment (Precise). b. Improper speed droop or voltage droop adjustment (utility).	a. Align or replace governor control unit (para. 4-7, MEP104A, or para. 4-7.1, MEP 114A). b. Check and adjust voltage and speed droop as necessary ( para. 3-20).
21. Frequency meter does not register	a. Defective control cubicle wiring harness assembly (figure 4-6). b. Defective frequency converter or frequency meter.	a. Repair or replace control cubicle wiring harness assembly (para. 4-2). b. Test or replace frequency converter and frequency meter (para. 4-2).
22. AC ammeter fails to register	a. Defective control cubicle wiring harness assembly (figure 4-6). b. Defective volts-amps transfer switch. c. Defective ac ammeter. d. Defective current transformer CT1, CT2, or CT3 (10, figure 5-9)	a. Repair or replace control cubicle wiring harness assembly (para. 4-2). b. Replace volts- amps transfer switch (para. 4-2). c. Replace ac ammeter ( para. 4-2). d. Test and replace defective transformers (para. 5-8).
23. Watt meter fails to register	a. Defective control cubicle wiring harness assembly (figure 4-6). b. Defective thermal watt converter or watt meter.	a. Repair or replace control cubicle wiring harness assembly ( para. 4-2). b. Replace thermal watt converter and watt meter (para. 4-2).
24. Frequency drifts.	a. Governor control unit out of alignment (Precise sets only). b. Engine runs erratically.	a. Align governor control unit (para. 4-7, MEP 104A, or 4-7.1, MEP 114A). b. See Malfunction 4 of this table.

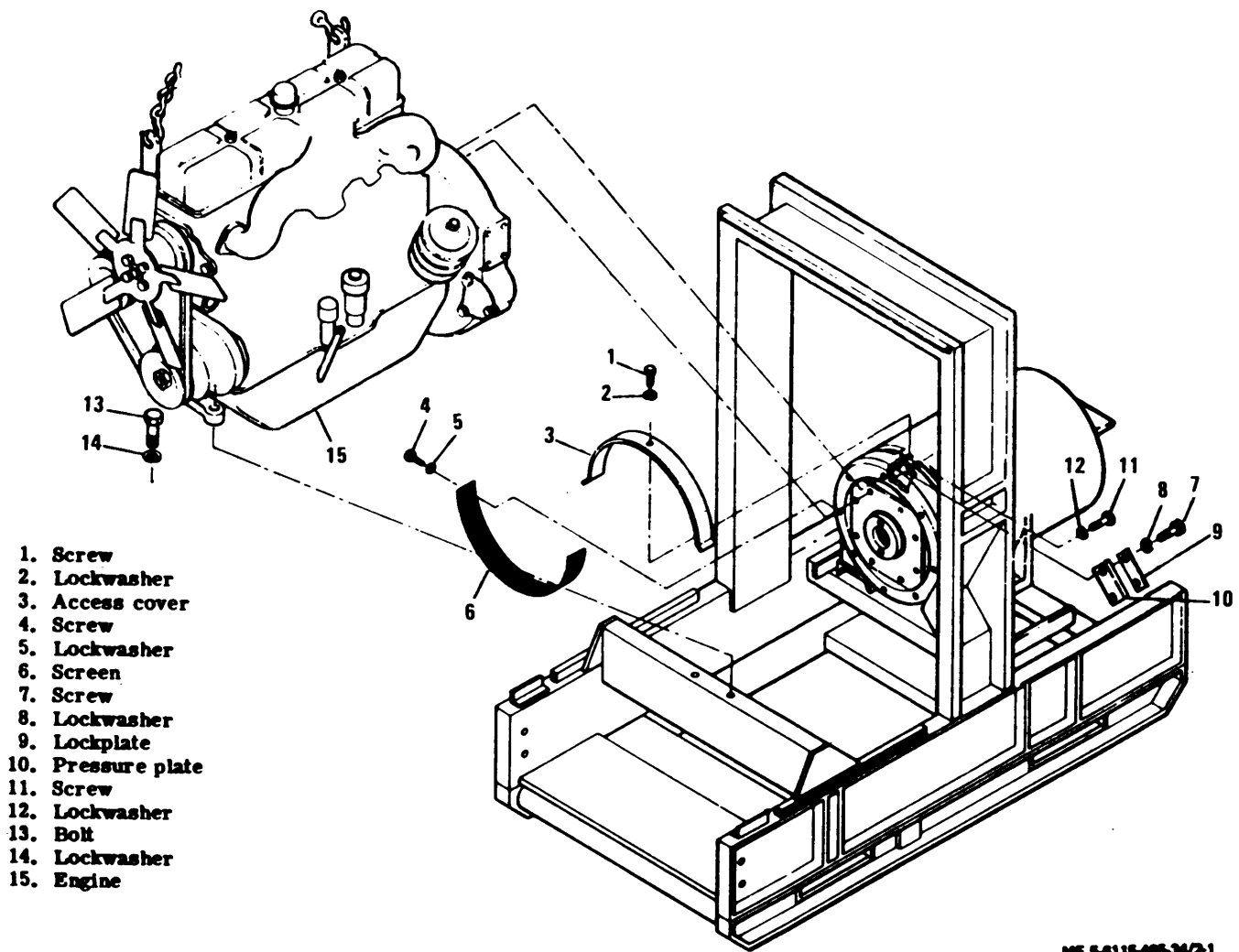

ME 5-6115-465-34/2-1

Figure 2-1. Engine Assembly, Removal And Installation

### Section III. REMOVAL AND INSTALLATION OF MAJOR COMPONENTS

#### 2-5. GENERAL.

a. The engine and generator are rigidly bolted together at the engine flywheel housing. This assembly is mounted on the skid base at three points. the front engine trunnion and the two generator feet. Rotation and cooling of the generator is accomplished by a blower and coupling disc assembly which is bolted to the engine flywheel. This arrangement allows the engine and generator to be removed as an assembly or independently of each other.

b. To remove the engine, it is first necessary to remove the radiator and shell assembly and disassemble the front housing assembly, rear housing assembly, and relay table (including relay table components, see Section III, Chapter 5). Engine accessories may either be removed or remain on the engine during removal.

c. To remove the generator, remove the rear housing assembly with cooling grille as a single unit. The relay table with the two side brackets can be removed as a unit by removing four bolts at base of side brackets and disconnecting wiring harness. Prior to loosening the bolts which couple the generator housing to the engine flywheel housing, the engine supporting bracket must be installed between the engine rear lifting bracket and the center support assembly.

d. In rare cases, it may be beneficial to remove the engine and generator as an assembly. To accomplish this, the housing assembly must be disassembled completely (a combination of the disassembly of sub-paragraphs b. and c. above) and the center support assembly removed. The lifting mechanism must be so arranged as to support both the engine and the generator to avoid undue stress on the engine-generator coupling.

#### 2-6. ENGINE ASSEMBLY REMOVAL AND INSTALLATION.

##### a. Removal.

(1) Refer to the operator and organizational maintenance manual and accomplish the following.

(a) Drain engine lubricating and cooling systems.

#### WARNING

To avoid short circuits which could damage equipment or injure personnel, always disconnect negative battery cable before performing maintenance on the electrical system,

(h) Remove radiator, radiator hoses, shell assembly, and shutter assembly.

(c) Remove front housing, doors and top panel.

(d) Disconnect fuel lines to fuel strainer, filter assembly, secondary fuel filter, and remove day tank.

(e) Drain hydraulic sump and disconnect hydraulic lines to hydraulic pump assembly (precise generator sets only).

(f) Tag and disconnect electrical leads to engine accessories and remove any clamps securing leads to engine.

(g) Remove air cleaner assembly and muffler.

(h) Disconnect starting aid tube assembly from engine intake manifold.

(i) If winterization kits are installed, tag and disconnect electrical leads to engine sensors and disconnect coolant lines from engine oil pan.

#### CAUTION

Do not use a lifting device of less than 1000 lb. capacity.

(2) Attach a suitable lifting device to engine lifting brackets.

(3) Disconnect engine crankcase oil drain tube from fitting in skid base.

(4) Remove screw (1, figure 2-1), lockwasher (2), and access cover (3).

(5) Remove screws (4), lockwashers (5) and air inlet screen (6).

(6) Remove screws (7) and lockwashers (8), lockplate (9) and pressure plate (10).

#### CAUTION

Take slack from hoisting sling prior to loosening generator and engine coupling bolts.

(7) Remove screws (11) and lockwasher (12).

(8) Remove bolts (13) and lockwashers (14).

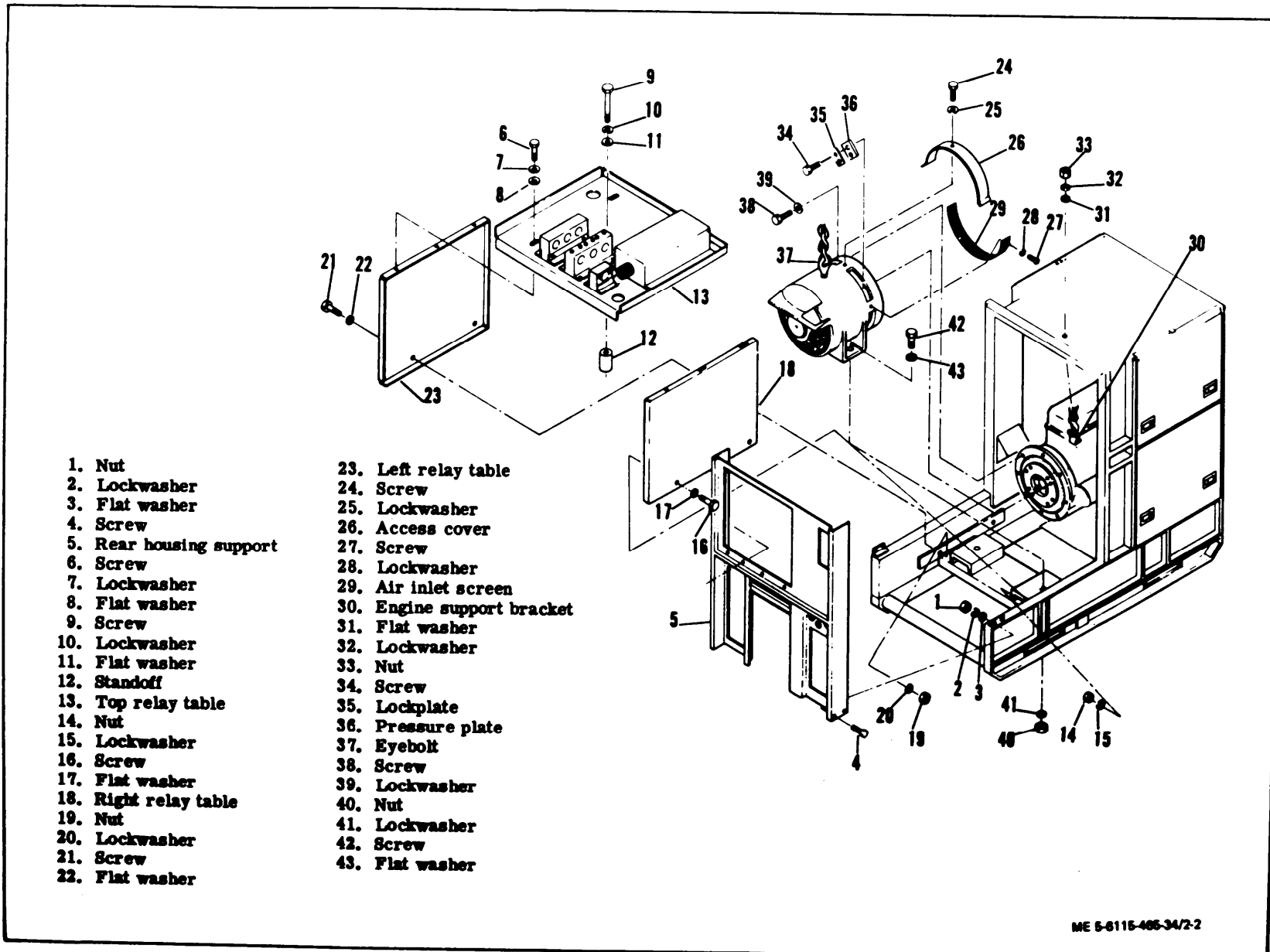

Figure 2-2. Generator Assembly, Removal and Installation

CAUTION

Make a final, thorough check to ascertain that the engine is completely disconnected from the generator set prior to attempting to hoist it clear.

(9) Carefully move the engine up and forward until generator coupling disc clears engine flywheel housing.

b. Installation. Install engine assembly in reverse order of removal procedures, with following additions:

(1) Alignment pins with 5/8 inch headless bolt should be screwed into holes in the flywheel to facilitate alignment.

(2) To install engine, use a suitable lifting device to lift engine by the hooks located on the engine.

(3) Tighten down engine bolts located in front of the engine to secure alignment. Torque according to paragraph 1-6v.

2-7. GENERATOR ASSEMBLY.

a. Removal.

(1) Refer to the Operator and Organizational Maintenance Manual and accomplish the following:

(a) Remove rear housing assembly, doors, top panel, and grille.

(b) Tag and disconnect wiring harnesses from control cubicle and relay table components.

NOTE

Record location and position of wiring harness support clamps prior to removal to facilitate installation.

(2) Tag and disconnect generator leads to voltage reconnection board.

NOTE

Record routing of generator leads through current transformers to facilitate installation.

(3) Tag and disconnect electrical leads between voltage reconnection board and load terminal board.

(4) Remove voltage reconnection board (see the Operator and Organizational Maintenance Manual).

(5) Remove main load contactor and special relay assembly (paragraphs 5-6 and 5-11).

(6) Remove nuts (1, figure 2-2), lockwashers (2), flat washers (3) and screws (4) to remove rear housing support (5).

(7) Remove screws (6), lockwashers (7) and flat washers (8).

(8) Remove screw (9), lockwasher (10), flat washer (11) and standoff (12) to remove top relay table (13).

(9) Remove nuts (14), lockwashers (15), screws (16) and flat washers (17) to remove right relay table (18).

(10) Remove nuts (19), lockwashers (20), screws (21) and flat washers (22) to remove left relay table (23).

(11) Remove screw (24), lockwasher (25) and access cover (26).

(12) Remove screws (27), lockwashers (28), and air inlet screen (29).

(13) Install engine support bracket (30), flat washer (31), lockwasher (32) and nut (33).

(14) Remove screws (34), lockplates (35), and pressure plates (36).

(15) Remove eyebolt (37) from generator set tool box and install into generator.

CAUTION

Do not use a lifting device of less than 1000 lb. capacity.

(16) Attach a lifting device to generator lifting eyebolt.

(17) Remove screws (38), lockwashers (39), nuts (40), lockwashers (41), screws (42) and flat washers (43).

(18) Carefully lift generator while moving it to the rear until coupling disc clears engine flywheel housing.

b. Installation.

(1) Install generator assembly in reverse order of removal instructions.

(2) Torque lock plate attaching screws (34, figure 2-2) to 120 ft.-lb. Bend lockplate over screw.

(3) Torque mounting screws and nuts (42 and 40, figure 2-2) to 200-220 ft.-lb.





## CHAPTER 3

### ENGINE REPAIR INSTRUCTIONS

#### Section I. ENGINE ELECTRICAL SYSTEM

##### 3-1. GENERAL

The engine electrical system consists of a starting circuit, a battery charging circuit, and protective and monitoring devices. Electrical power for cranking the engine is supplied by two 12 volt, 100 amp-hour lead-acid type batteries connected in series. A slave receptacle facilitates external connection to the batteries. The starter assembly is a 24 volt, heavy duty unit consisting of a starting motor, a solenoid, and a drive assembly. The battery charging alternator with integral voltage regulator and diode rectifier recharges and maintains the batteries in a fully charged condition after starting.

##### 3-2. BATTERIES

Refer to the Operator and Organizational Maintenance Manual for battery maintenance procedures.

##### 3-3. SLAVE RECEPTACLE.

Refer to the Operator and Organizational Maintenance Manual for slave receptacle maintenance procedures.

##### 3-4. STARTER ASSEMBLY.

a. Removal. Refer to the Operator and Organizational Maintenance Manual for starter removal procedures.

b. Disassembly.

(1) Remove nut (1, figure 3-1), lockwasher (2) and terminal lead (3).

(2) Remove screws (4) to remove solenoid assembly (5) from starter assembly.

(3) Remove nut (6), flat washer (7), and insulating washer (8).

(4) Remove nut (9), lockwasher (10), nut (11), flat washer (12) and insulating washer (13).

(5) Remove screws (14) and flat washers (15) to remove cover (16) and gasket (17) from frame assembly (18). Discard gasket.

(6) Remove nuts (19), lockwashers (20), nuts (21), flat washers (22), and insulating washers (23) to remove terminal studs (24 and 25) and contact strip (26).

(7) Remove spring (27) and contact assembly (28).

(8) Remove plug (29), retaining ring (30), pin (31) and boot clamp (32) to remove plunger (33).

(9) Remove retaining ring (34) to remove spring retainer (35), spring (36), boot (37), spring retainer (38), washer (39), and retaining ring (40) from plunger (33).

(10) Remove bolts (41) to remove commutator end frame (42), packing (43) and spacer washer (44).

(11) Remove plug (45) and oil wick (46).

(12) Do not remove bushing (47) unless inspection reveals defective parts.

(13) Remove pin (48) to remove brush spring (49) and brushholders (50).

(14) Remove screws (51), electrical leads (52) and brushes (53) from brushholders (50).

#### CAUTION

Use care when removing armature to prevent damage to windings.

(15) Slide armature (54) from housing (55).

(16) Remove nut (56), flat washer (57), and insulating washer (58).

(17) Remove screws (59) to remove pole shoes (60), field coil assembly (61) and insulator (62).

(18) Remove and discard o-ring (63) and packing (64).

(19) Remove screws (65) and lockwashers (66) to remove drive housing (67) and gasket (68). Discard gasket.

(20) Remove plug (69) and oil wick (70).

(21) Do not remove bushing (71) unless inspection reveals defects.

(22) Remove plug (72) to remove pivot pin (72).

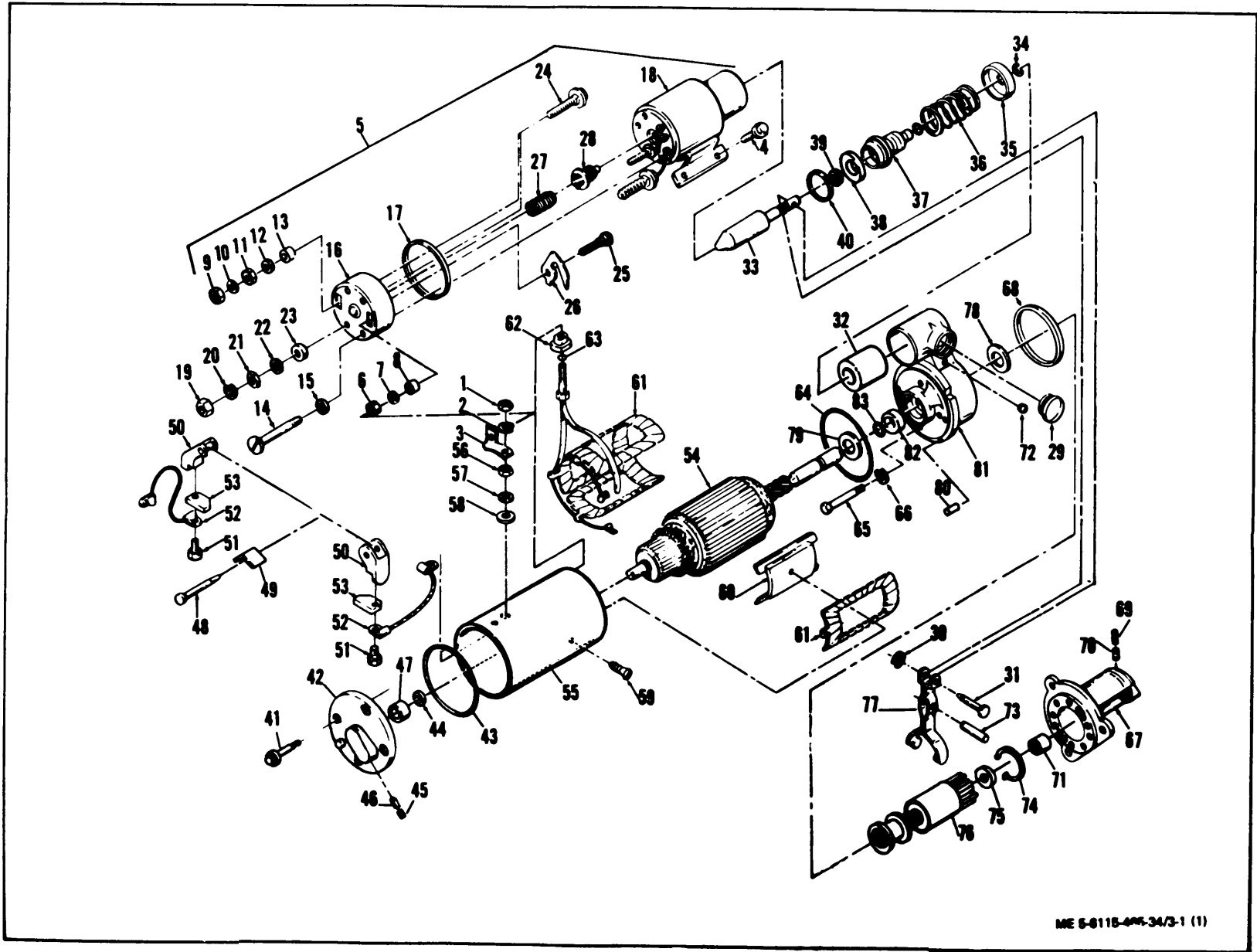

Figure 3-1. Starter Assembly, Exploded View (Sheet 1 of 2)

TM 5-6115-465-34  
TO 35C2-3-446-2  
NAVFAC P-8-625-34  
TM 06858B/06859D-34

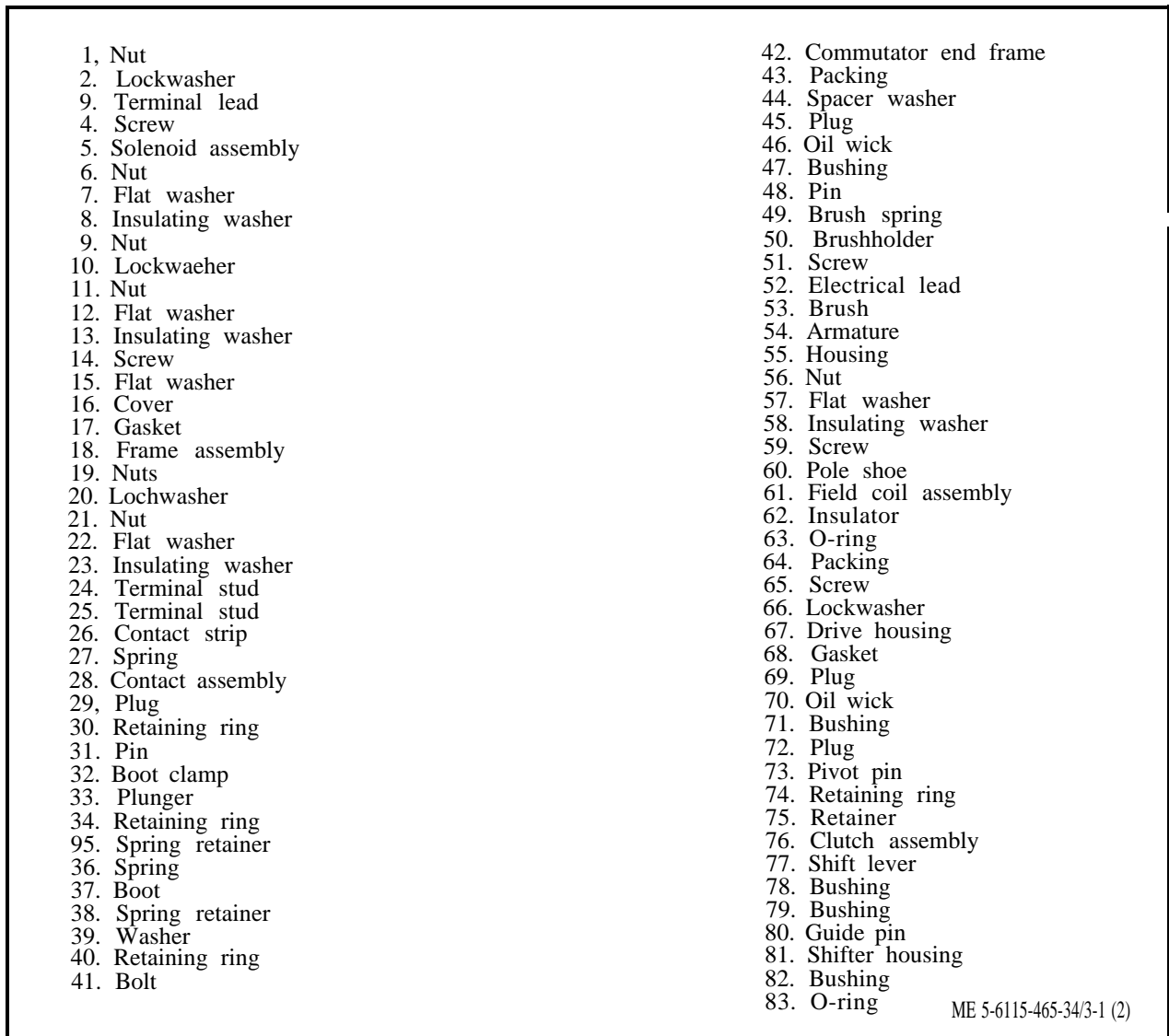

Figure 3-1. Starter Assembly, Exploded View (Sheet 2 of 2)

(23) Remove retaining ring (74) and retainer (75).

(24) Rotate clutch assembly (76) counterclockwise to remove from shaft of armature (54),

(25) Remove shift lever (77), but do not remove bushings (78 and 79) or guide pin (80) from shifter housing (81) unless inspection reveals defects.

(26) Remove bushing (82) and o-ring (83).

c. Cleaning, Inspection, and Repair.

**CAUTION**

Do not use dry cleaning solvent to clean electrical parts.

(1) Clean all metal non-electrical parts in an approved solvent and dry thoroughly with filtered compressed air.

**CAUTION**

When cleaning field coils, use extreme care to avoid damaging protective insulation.

(2) Clean field coils with a clean, lint-free cloth lightly moistened with an approved solvent and dry thoroughly with filtered compressed air.

(3) Remove loose particles from armature with filtered compressed air and wipe clean with a cloth lightly moistened with an approved solvent. Clean commutator lightly with No. 00 grit sand paper. Remove all traces of dust with low pressure compressed air.

(4) Clean non-metallic washers, insulators, and seals with a clean, lint-free cloth lightly moistened with an approved solvent.

#### CAUTION

Do not allow solvent to contact brushes.

(5) Clean brushes with a clean, lint-free cloth.

(6) Inspect housings and frames for cracks, corrosion, and distortion. Replace defective parts.

(7) Inspect bushings for wear, galling, and scores. Replace defective parts.

(8) Test armature for grounding as follows:

(a) Connect one lead of a test light to the armature core.

(b) Touch the other test lead to each commutator riser.

(c) If test light glows, armature is grounded and must be replaced.

(9) Test armature for short circuits as follows :

(a) Place armature on a growler fixture.

(b) Activate the fixture and slowly rotate armature while touching armature lightly with a steel strip.

(c) Strip will vibrate against armature over a shorted area.

(d) Replace armature if a short is indicated.

(10) Turn down armature if scored or out of round. Under cut mica to a depth of 0.025 to 0.032 inch below surface of commutator. Use care to avoid widening commutator slots.

#### NOTE

Check diameter of commutator after removing material. Diameter shall not be less than 1.6470 inches.

(11) Use an ohmmeter to check field coils for insulation breakdown as follows:

(a) Attach one lead to field housing and the other lead to field coil terminal.

(b) Replace field coil if a reading of less than 1 megohm is indicated.

(12) Inspect drive assembly for badly worn or broken teeth. Check internal spline for wear and damage. Check spring for cracks, breaks, and distortion. Replace drive assembly if defective.

(13) Inspect brushholders and support for cracks, corrosion, and other damage. Replace defective parts.

(14) Measure brush length. Replace brushes if length is 5/16 inch or less.

(15) Test brush spring tension with a spring tester. Tension shall be 36 ounces to 40 ounces. Replace brush springs if tension is less than specified.

(16) Inspect all threaded parts for trussed, stripped or peened threads. Replace damaged parts.

(17) Using an ohmmeter, test for continuity across terminals of solenoid frame assembly. There shall be no sign of open circuit.

(18) Check solenoid frame assembly for grounding by touching one lead of ohmmeter to either lead and the other to the frame casing. There shall be no sign of continuity.

(19) Smooth scratches, burrs, and nicks on any machined surfaces using a fine file. Remove all filings before reassembly.

(20) Repair minor thread damage using thread chasers, taps, and dies. Clean threads to remove metal particles.

(21) Remove minor rough spots, scores, and scratches from bushings using fine crocus cloth or a fine stone dipped in cleaning solvent. Wash the bushings thoroughly in cleaning solvent to remove all grit and metal particles.

d. Assembly.

(1) Assemble starter assembly in reverse order of removal procedures using new gaskets.

(2) If brushes were replaced, run in new brushes as follows:

(a) Cover armature commutator with a piece of No. 00 grit sandpaper.

(b) Temporarily install brushes and commutator end frame and run in brushes.

(c) Disassemble, remove sandpaper, and clean armature commutator and brushholder assembly with filtered compressed air.

e. Testing

(1) Test overrun clutch as follows:

(a) Rotate drive gear back and forth, Gear should turn freely in direction of motor rotation and rotate armature shaft in other direction.

(b) If gear turns armature shaft in both directions, the overrun clutch is binding and must be replaced.

(c) If gear does not rotate armature shaft in either direction, the overrun clutch is slipping and must be replaced.

(2) Test starter solenoid assembly as follows:

(a) Remove terminal lead (3, figure 3.1).

(b) Apply 24 Vdc between the negative terminal and the small terminal of the solenoid assembly.

(c) Solenoid actuation will be indicated by an audible "click" and rearward movement of the drive gear.

(d) Remove 24 Vdc from solenoid assembly terminals.

(e) The drive gear should move forward with an audible click.

(f) Replace solenoid assembly if it fails to function properly.

(g) Install terminal lead.

(3) Conduct starter assembly motoring test as follows:

(a) Remove terminal lead (3, figure 3-1).

(b) Install starter assembly into motoring test circuit shown in figure 3-2.

(c) Adjust rheostat until voltmeter indicates 22.5 volts.

(d) Check indications of ammeter and tachometer.

(e) Ammeter should indicate 58 amperes maximum with starter turning at 9300 rpm.

(f) If current and speed are low, disassemble starter and check for high resistance at internal connections.

(g) If current is high and rpm low, disassemble and inspect armature shaft and bushings for wear or misalignment.

(h) Do not install terminal lead (3, figure 3-1) until stalled torque test is completed.

(4) Conduct starter assembly stalled torque test as follows:

**CAUTION**

Rheostat must have a minimum capacity of 1000 amperes.

(a) Install starter assembly in test setup shown in figure 3-3.

(b) Adjust rheostat until voltmeter indicates 14 Vdc.

(c) Ammeter should indicate 540 amperes maximum at a minimum torque of 26 ft-lb indicated on scale.

(d) If both current and torque are low, disassemble the starter and check for poor internal connections or improper brush contact. Both of these conditions would result in high internal resistance.

(e) High current and low torque may be caused by defective armature or field coil assembly.

(f) Remove starter assembly from test setup and install terminal lead (3, figure 3-1).

f. Installation. Refer to the Operator and Organizational Maintenance Manual for starter assembly installation procedures.

3-4.1. STARTER ASSEMBLY. Effective with serial numbers RZ70001 and KZ00001 thru KZ02752).

a. Removal. Refer to the Operator and Organizational Maintenance Manual for starter removal procedures.

b. Disassembly.

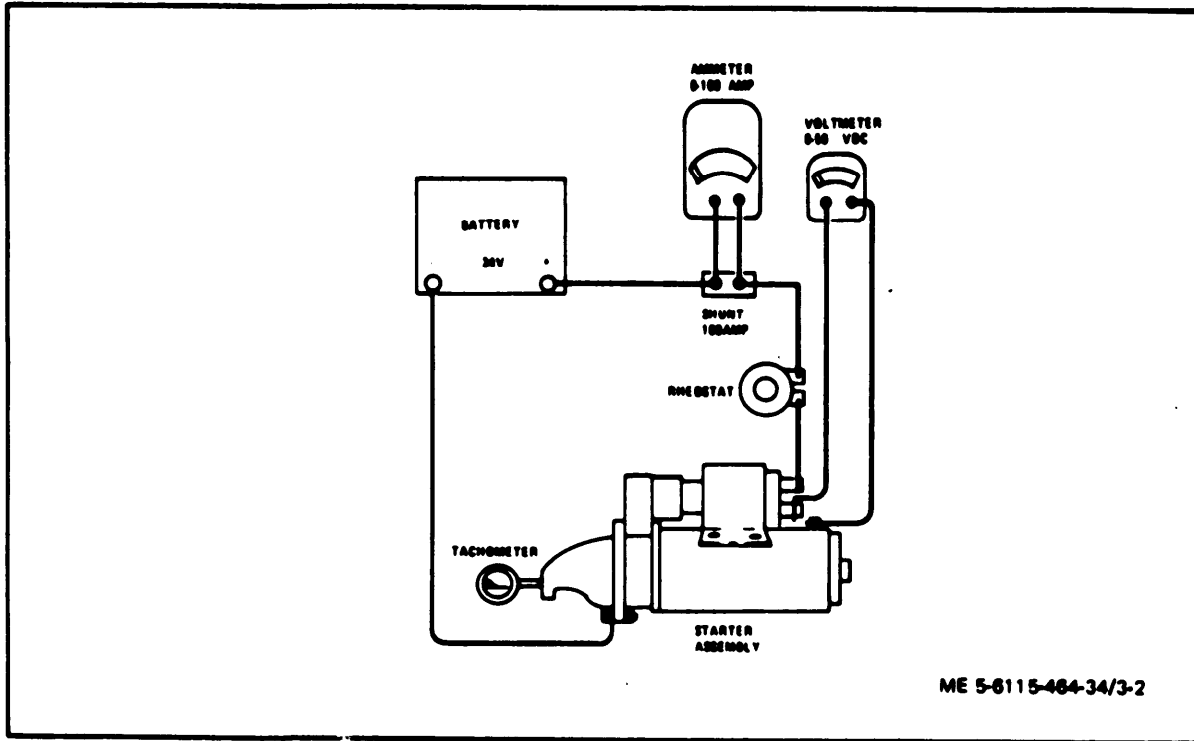

Figure 3-2. Starter Assembly Motoring Test Circuit

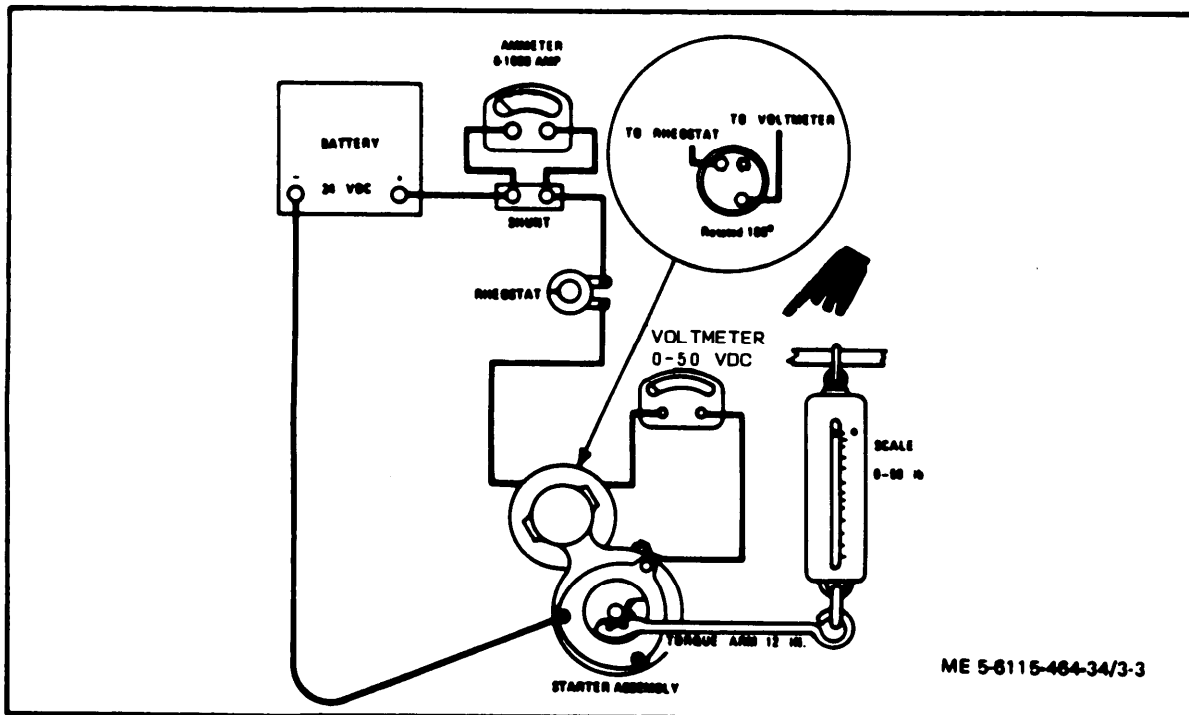

Figure 3-3. Starter Assembly Stalled Torque Setup

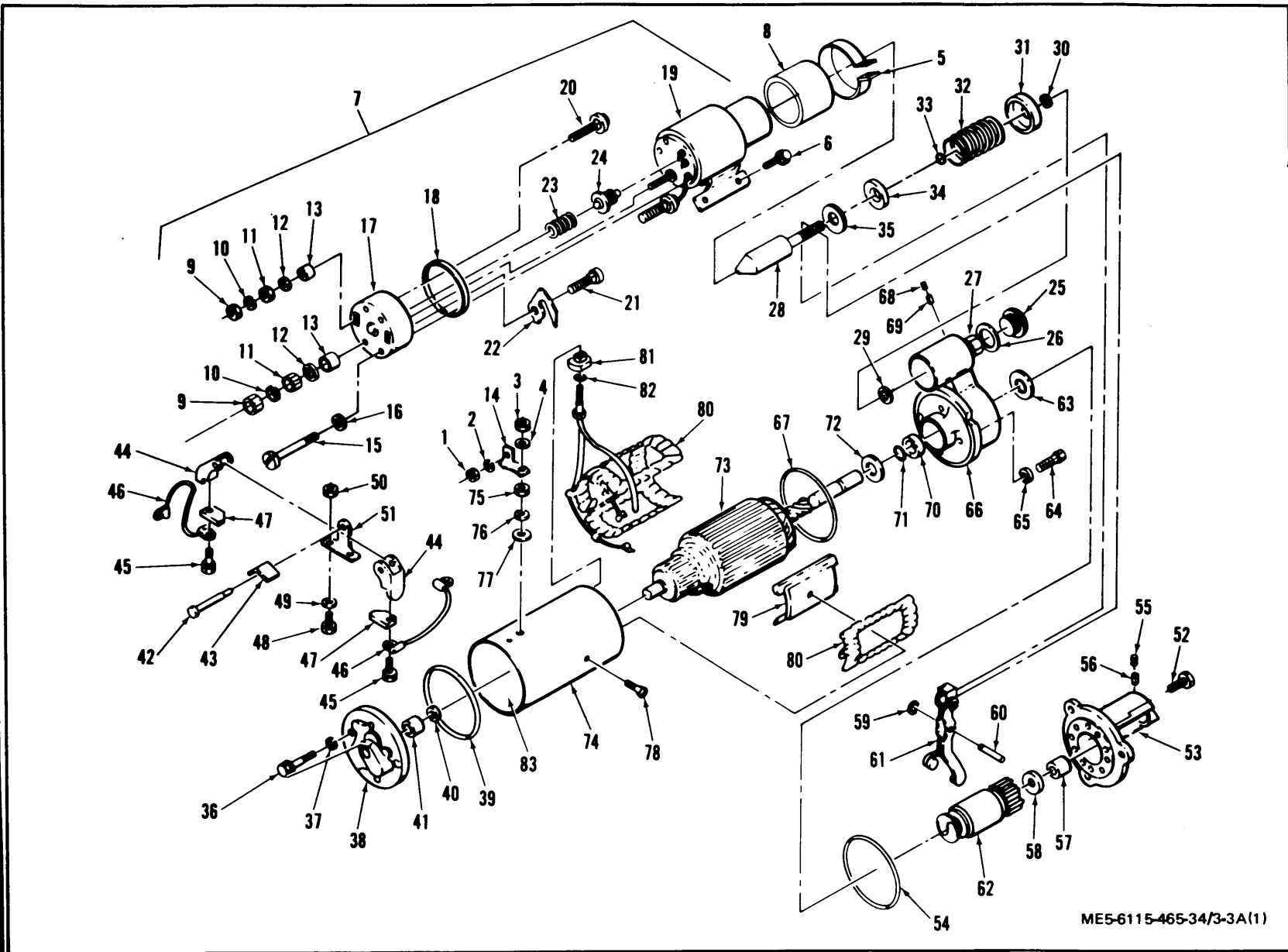

Figure 3-31.1. Starter Assembly, Exploded View (Effective with Serial No. RZ70001 and KZ00001 thru KZ02752) (Sheet 1 of 2).

TMS-6115-465-34  
NAVFAC P-8-625-34  
T.O. 35C2-3-446-2  
TM 06858B/06859D-34

1. Nut	43. Brush spring
2. Lockwasher	44. Brushholder
3. Nut	45. Screw
4. Lockwasher	46. Electrical lead
5. Clamp	47. Brush
6. Screw	48. Screw
7. Solenoid Assembly	49. Lockwasher
8. Boot	50. Nut
9. Nut	51. Brush support
10. Lockwasher	52. Screw
11. Nut	53. Drive housl
12. Flat washer	54. O-ring
13. Insulating washer	55. Plug
14. Connector	56. Wick
15. Screw	57. Bushing
16. Flat washer	58. Washer
17. Cover	59. Snap ring
18. Gasket	60. Lever shaft
19. Solenoid frame assy	61. Lever
20. Terminal stud	62. Motor drive
21. Terminal stud	63. Brake washer
22. Terminal clip	64. Screw
23. Spring	65. Lockwasher
24. Contact	66. Lever housing
25. Inspection plug	67. O-ring
26. Gasket	68. Plug
27. Adjusting nut	69. Wick
28. Plunger	70. Bushing
29. Snap ring	71. O-ring
30. O-ring	72. Space washer
31. Spring retainer	73. Armature
32. Spring	74. Field frame
33. O-ring	75. Nut
34. Spring retainer	76. Washer
35. Washer	77. Insulating washer
36. Screw	78. Screw
37. Lockwasher	79. Pole shoe
38. Commutator end fraem	80. Field coil
39. O-ring	81. Insulator
40. Space washer	82. O-ring
41. Bushing	83. Insulation
42. Pin	

ME5.6115-W65-34/3-3A(2)

Figure 3.31.1. Starter Assembly. Exploded View (Effective with Serial No. RZ70001 and KZ00001 thru KZ02752) (Sheet 2 of 2)

(1) Remove nut (1, figure 3-3. 1), lockwasher (2), nut (3) and lockwasher (4).

(2) Loosen clamp (5) and remove screws (6) to remove solenoid assembly (7) from starter assembly.

(3) Remove boot (8) and clamp (5).

c. Solenoid disassembly.

(1) Remove nuts (9), lockwashers ( 10), nuts(11 ), flat

washers (12), insulating washers (13) and connector (14).

(2) Remove screws (15) and flat washers (16) to remove cover (17) and gasket ( 18) from solenoid frame assembly (19)

(3) Remove terminal studs (20 and 21) and terminal clip (22) from cover (17). Remove spring (23) and contact (24).

d. Starter Disassembly.



(1) Remove inspection plug(25) and gasket (26). Remove adjusting nut (27) to remove plunger (28).

(2) Remove snap ring(29), o-ring (30), spring retainer(31 ), spring (32), o-ring (33), spring retainer (34) and washer (35) from plunger (28).

(3) Remove screws (36) and lockwashers (37) to remove commutator end frame (38), o-ring (39) and space washer (40).

(4) Do not remove bushing (41) unless inspection reveals damaged parts.

(5) Remove pins (42) to remove brush springs (43) and brushholders (44).

(6) Remove screws (45), electrical leads (46) and brushes (47) from brushholders(44).

(7) Remove screws (48), lockwashers (49), and nuts (5C) to remove brush supports (51).

(8) Remove screws (52) to remove drive housing (53) and o-ring (54).

(9) Remove plug (55) and wick (56).

(10) Do not remove bushing (57) unless inspection reveals damage,

(11) Remove drive end washer (58).

(12) Remove snap ring (59), lever shaft (60), lever (61 ), motor drive (62), and brake washer (63).

(13) Remove screws (64) and lockwashers (65) to remove lever housing (66) and o-ring (67).

(14) Remove plug (68) and wick (69).

(15) Remove bushing (70) o-ring (71 ) and spacer washer (72).

#### CAUTION

Use care when removing armature to prevent damage to windings.

(16) Slide armature (73) from field frame (74).

(17) Remove nut (75), washer (76) and insulating washer (77).

(18) Remove screws (78) to remove pole shoes (79), field coil (80) and insulator (81 ). Remove o-ring (82).

(19) Inspect field coil insulation (83). Replace if damage is evident.

e. Cleaning, Inspection and Repair.

#### CAUTION

Do not use dry cleaning solvent to clean electrical parts.

(1) Clean all metal nonelectrical parts in an approved solvent and dry thoroughly with filtered compressed air.

#### CAUTION

When cleaning field coils, use extreme care to avoid damaging protective insulation.

(2) Clean field coils with a clean, lint-free cloth lightly moistened with an approved solvent and dry thoroughly with filtered compressed air.

(3) Remove loose particles from armature with filtered compressed air and wipe clean with a cloth lightly moistened with an approved solvent. Clean commutator lightly with No. 00 grit sandpaper. Remove all traces of dust with low pressure compressed air.

(4) Clean non-metallic washers, insulators, and seals with a clean, lint-free cloth lightly moistened with an approved solvent.

#### CAUTION

Do not allow solvent to contact brushes.

(5) Clean brushes with a clean, lint-free cloth.

(6) Inspect housing and frames for cracks, corrosion, and distortion. Replace defective parts.

(7) Inspect bushings for wear, galling, and scores. Replace defective parts.

(8) Test armature for grounding as follows:

(a) Connect one lead of a test light to the armature core.

(b) Touch the other test lead to each commutator riser.

(c) If test light glows, armature is grounded and must be replaced.

(9) Test armature for short circuits as follows:

(a) Place armature on a growler fixture.

(b) Activate the fixture and slowly rotate armature while touching armature lightly with a steel strip.

(c) Strip will vibrate against armature over a shorted area.

(d) Replace armature if a short is indicated.

(10) Turn down armature if scored or out of round. Under cut mica to a depth of 0.025 to 0.032 inch below surface of commutator. Use care to avoid widening commutator slots.

NOTE

Check diameter of commutator after removing material. Diameter shall not be less than 1.6470 inches.

(11) Use an ohmmeter to check field coils for insulation breakdown as follows:

(a) Attach one lead to field housing and the other lead to field coil terminal.

(b) Replace field coil if a reading of less than 1 megohm is indicated.

(12) Inspect drive assembly for badly worn or broken teeth. Check internal spline for wear and damage. Replace drive assembly if defective.

(13) Inspect brushholders and support for cracks, corrosion, and other damage. Replace defective parts.

(14) Measure brush length. Replace brushes if length is 5/16 inch or less.

(15) Test brush spring tension with a spring tester. Tension shall be 36 ounces to 40 ounces. Replace brush springs if tension is less than specified.

(16) Inspect all threaded parts for crossed, stripped or panned threads. Replace damaged parts.

(17) Using an ohmmeter, test for continuity across terminals of solenoid frame assembly. *There* shall be no sign of open circuit,

(18) Check solenoid frame assembly for grounding by touching one lead of ohmmeter to either lead and the other to the frame casing. There shall be no sign of continuity.

(19) Smooth scratches, burrs, and nicks on any machined surfaces using a fine file. Remove all fillings before re-assembly.

(20) Repair minor thread damage using thread chasers, taps and dies. Clean threads to remove metal particles.

(21) Remove minor rough spots, scores, and scratches from bushings using crocus cloth or a fine stone dipped in cleaning solvent. Wash the bushings thoroughly in cleaning solvent to remove all grit and metal particles.

f. Assembly.

(1) Assemble starter and solenoid in reverse order of disassembly procedures using new gaskets and o-rings. Inspect all insulating washers and bushings. Replace if defective.

(2) If brushes were replaced, run in new brushes as follows:

(a) Cover armature commutator with a piece of No. 00 grit sandpaper.

(b) Temporarily install brushes and commutator end frame and run in brushes.

(c) Disassemble, remove sandpaper, and clean armature commutator and brushholder assembly with filtered compressed air.

g. Testing.

(1) Test starter solenoid assembly as follows:

(a) Remove connector (14, Figure 3-3. 1).

(b) Apply 24 Vdc Between the negative terminal and the small terminal of the solenoid assembly.

(c) Solenoid actuation will be indicated by an audible "click" and rearward movement of the drive gear.

(d) Remove 24 Vdc from solenoid assembly terminals.

(e) The drive gear should move forward with an audible click.

(f) Replace solenoid assembly if it fails to function properly.

(g) Install connector.

(2) Conduct starter assembly motoring test as follows:

(a) Remove connector (14, Figure 3-3. 1).

(b) Install starter assembly into motoring test circuit shown in figure 3-2.

(c) Adjust rheostat until voltmeter indicates 22.5 volts.

(d) Check indications of ammeter and tachometer.

(e) Ammeter should indicate 58 amperes maximum with starter turning at 9300 rpm.

(f) If current and speed are low, disassemble starter, and check for high resistance at internal connection.

(g) If current is high and rpm low, disassemble and inspect armature shaft and bushings for wear or misalignment.

(h) Do not install connector (14, Figure 3-3.1) until stalled torque test is completed.

(3) Conduct starter assembly stalled torque, test as follows:

CAUTION

Rheostat must have a minimum capacity of 1000 amperes.

(a) Install starter assembly in test setup shown in figure 3-3.

(b) Adjust rheostat until voltmeter indicates 14 Vdc.

(c) Ammeter should indicate 540 amperes maximum at a minimum torque of 26 ft-lb indicated on scale.

(d) If both current and torque are low, disassemble the starter and check for poor internal connections or improper brush contact. Both of these conditions would result in high internal resistance.

(e) High current and low torque may be caused by defective armature or field coil assembly.

(f) Remove starter assembly from test setup and install connector (14, Figure 3-3.1).

h. Installation. Refer to the Operator and Organizational Maintenance Manual for starter assembly installation procedures.



### 3-5. BATTERY CHARGING ALTERATOR

Removal Refer to the Operator and Organizational Maintenance Manual for battery charging alternator removal procedures.

#### b. Disassembly.

(1) Remove screws (1, figure 3-4) and carefully pull regulator and cover assembly (2) away from alternator.

(2) Tag and disconnect electrical leads to completely separate regulator and cover assembly from alternator.

(3) Unsolder blue and brown leads from fuse holder (3). Remove nut (4), fuse holder (3) and washer (5) from cover assembly (2).

(4) Remove fuse holder cap (6) and fuse (7).

(5) Remove screws (8) and cover band (9).

(6) Remove thru bolts (10) and remove head assembly (11).

(7) Remove nuts (12 and 13), lockwasher (14) and lead (15).

(8) Remove screws (16), lockwashers (17), insulating plate (18), brushholder (19) and brush and spring assembly (20).

(9) Remove nuts (21, 22, and 23), lockwasher (24), screw (25) and flat washers (26) to remove capacitor and clamp assembly (27).

#### NOTE

If capacitor and clamp assembly (28) was not removed and tagged when performing step 3-5b. (2) above, remove and tag at this time.

(10) Remove nuts (29 and 30), flat washers (31, 32, 33 and 34). Remove rear part of insulating brushings (36, 37, 38, and 39), and remove rectifier and stator assembly (40) from head assembly (11).

(11) Unsolder leads and remove negative plate and rectifier assembly (41) and positive plate and rectifier assembly (42) from stator (43). Remove

front part of insulating bushings (36, 37, 38 and 39) and Studs (35).

(12) Clamp pulley in a soft-jawed vise and remove nut (44).

(13) Remove assembly from vise and remove pulley (45) and fan (46).

#### NOTE

Use of a puller may be necessary if pulley sticks to rotor shaft.

(14) Pry woodruff key (47) from keyway in rotor shaft and remove spacer (48).

(15) Support head assembly (49) and using a center punch in the indentation in the end of the rotor shaft, drive the rotor assembly (50) out of the head assembly (49).

(16) Remove snap ring (51) and bearing (52) and o-ring (55).

#### NOTE

It may be necessary to press or drive the bearing (52) out of the head assembly (49).

(17) Use a bearing puller to remove rear bearing (53) from rotor assembly (50).

(18) Remove cover (54) and o-ring (55).

#### c. Cleaning, Inspection, and Repair.

(1) Clean all non-electrical parts (housing fan, bearings, etc. ) in an approved solvent and dry with filtered compressed air.

(2) Clean all electrical parts with a soft bristled brush and filtered compressed air.

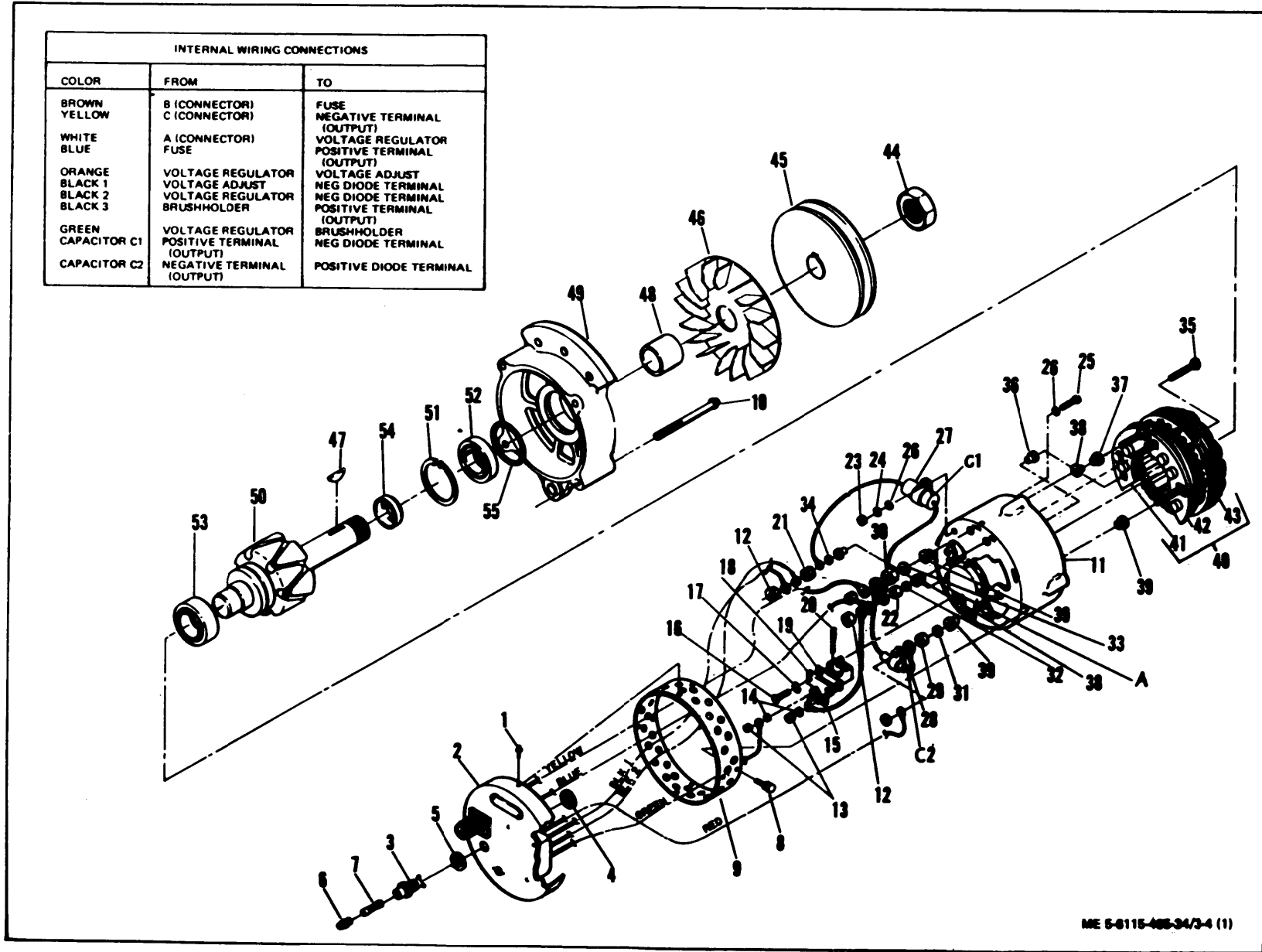

Figure 3-4. Alternator Assembly, Exploded View (Sheet 1 of 2)

TM 5-6115-465-34  
 TO35C2-3-446-2  
 NAVPAC P-8-625-34  
 TM06858B/06859D-34

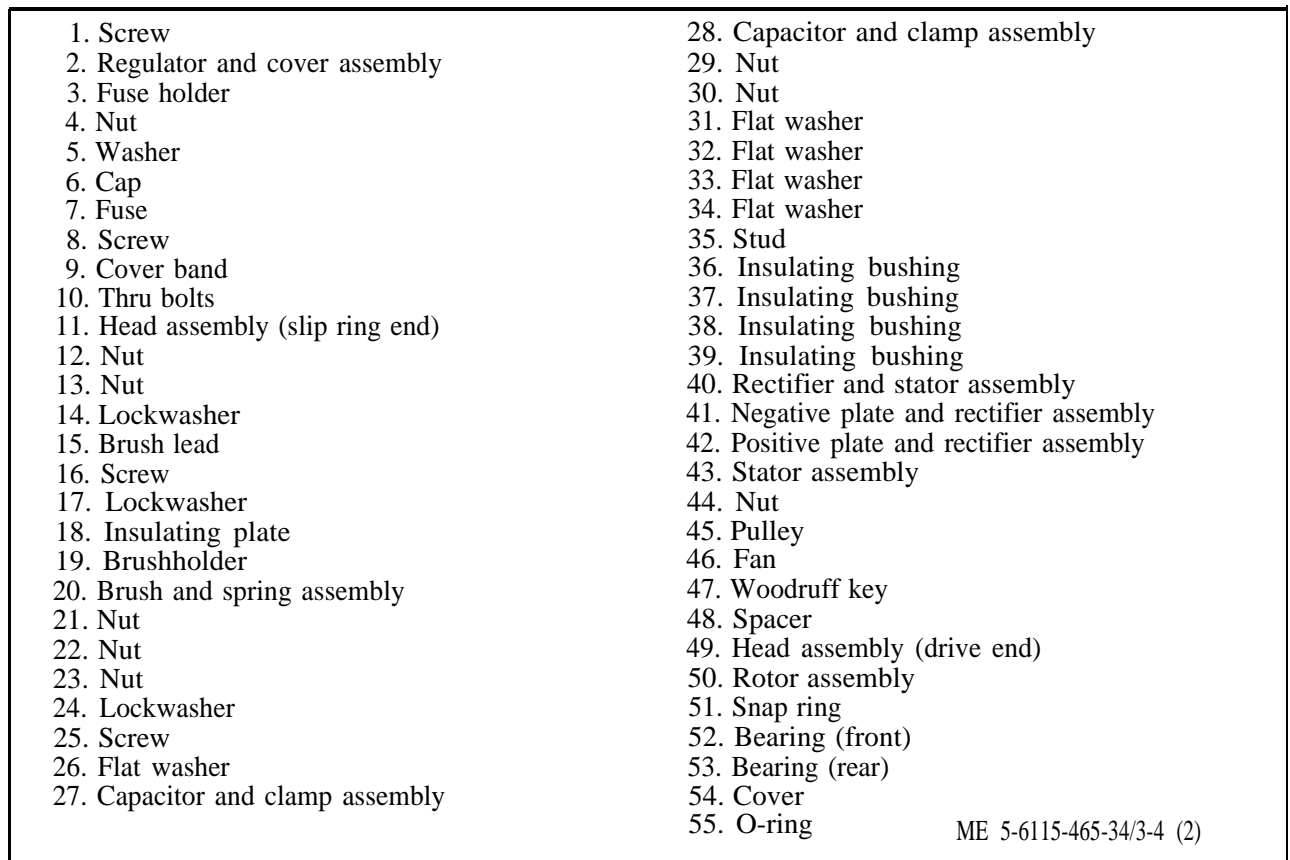

Figure 3-4. Alternator Assembly, Exploded View (Sheet 2 of 2)

(3) Inspect plate and rectifier assemblies for cracks, corrosion, and evidence of shorting or other damage.

(4) Using an ohmmeter or similar testing device, test positive diode rectifier assembly as follows:

(a) Connect positive lead of tester to heat sink and touch negative lead to lead of each diode. Tester should indicate open circuit at each diode.

(b) Connect negative lead to heat sink and touch positive lead to each diode lead. Tester should indicate continuity at each diode.

(c) Replace positive diode rectifier assembly if any of the diodes fail to test correctly.

(5) Test negative diode rectifier assembly as follows:

(a) Connect negative lead of tester to heat sink and touch positive lead to lead of each diode. Tester should indicate open circuit at each diode.

(b) Connect positive lead of tester to heat sink and touch negative lead to lead of each diode. Tester should indicate continuity at each diode.

(c) Replace negative diode rectifier assembly if any diode fails to test correctly.

(6) Visually inspect stator assembly for rub marks on the interior diameter, evidence of burned or shorted windings, and other damage.

(7) Using an ohmmeter, check continuity of each phase of stator assembly. Replace stator assembly if ohmmeter indicates open circuit of one or more phase.

(8) Visually inspect rotor assembly for rub marks and bums or other evidence of shorting. Inspect shaft for worn key slot and bearing surfaces.

(9) Test rotor assembly as follows:

(a) Install rotor assembly in test setup shown in figure 3-5.

(b) Adjust rheostat until voltmeter indicates 20 Vdc.

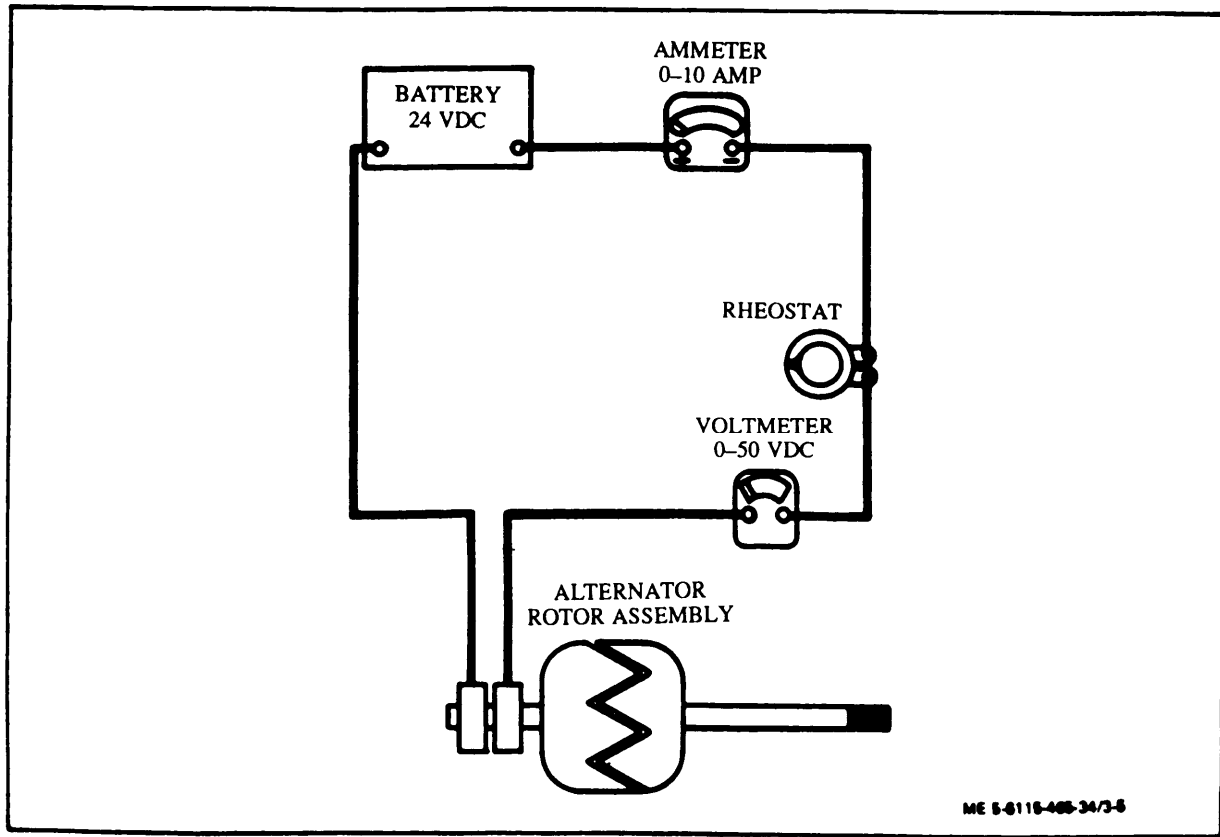

Figure 3-5. Rotor Assembly Current Draw Test Circuit.

(c) Ammeter should indicate 2.8 to 3.0 amperes at 70° to 80°F (21.1° to 26.7°C).

(d) High current reading on ammeter indicates low resistance or a shorted rotor warning.

(e) Using an ohmmeter, check resistance across slip rings. Resistance should be 7.5 to 8.0 ohms at an ambient temperature of 70° to 80°F (21.1° to 26.7°C).

(10) Replace rotor assembly if inspection and test requirements are not met.

(11) Inspect voltage regulator connector, cover assembly, and voltage adjust for cracks, corrosion, and evidence of shorting or other damage.

(12) Inspect fuse holder for cracks, corrosion, and other damage. Check fuse for burned out condition. Check fuse for continuity if in doubt.

(13) Inspect brush assembly for corrosion and excessive wear.

NOTE

The brushes are excessively worn if 3/16 inch or less extends beyond the bottom of the holder.

(14) Check brush spring tension. A force of 4 to 6 ounces should move brush against spring.

(15) Using an ohmmeter, test brushholder assembly as follows:

(a) Attach one test lead to brushholder and touch other lead to each terminal and each brush. There should be no indication of continuity between brushholder and any terminal or brush.

(b) Check for continuity between each terminal and its respective brush.

(16) Replace brushholder assembly if inspection and test requirements are not met.

(17) Inspect pulley for excessive wear at pulley groove, cracks, corrosion, and other damage.



(18) Inspect fan for cracks, corrosion, bent blades and other damage.

(19) Inspect bearings for pitting, excessive wear, and other damage.

(20) Inspect head assemblies (11 and 49) for cracks, breaks, and corrosion.

(21) Inspect all threads for crossing, stripping, and peening.

d. Assembly.

(1) Install positive diode rectifier assembly (42, figure 3-4) and negative diode rectifier assembly (41 ) onto stator assembly (43) and solder diode leads.

(2) Using a driver which exerts pressure on the inter race only, install front bearing (52 ) into front head (49) and secure with snap ring (51).

(3) Install cover (54) and support rear bearing area of rotor assembly (50) on a suitable press and fit assembled front head and bearing over rotor shaft. Using a driver which exerts pressure on the inner race sly, press front head down until front bearing contacts cover (54) on rotor shaft.

(4) Support front of rotor assembly shaft on a suitable press. Using a driver which contacts the inner race only, press rear bearing (53) onto rotor shaft until it contacts shoulder on shaft. Remove rotor assembly from press.

(5) Install spacer (48), woodruff key (47), fan (46), pulley (45), and nut (44). Torque nut to 35 to 50 ft-lbs

(6) Fit front part of insulating bushings (36, 37, 38, and 39) over rectifier studs.

(7) Position stator and rectifier assembly (40) into rear head assembly (11).

(8) Install rear part of insulating bushings (36, 37, 38 and 39) and washers (31, 32, 33, and 34).

(9) Install brushholder (19), insulating plate (18), lockwashers (17) and screws (16).

NOTE

Insure that the contour of the brushes correspond to the contour of the com - mutator when installing brushes in the brushholder.

(10) Install brush and spring assemblies (20) in brushholder (19).

(11) Insert a wire of sufficient stiffness in the access hole provided (point A, figure 3-4), to hold the brushes (20) depressed into the brushholder (19).

(12) Install the rotor (50) with assembled front head (49) into rear head (11), assembled together with rectifier and stator assembly (40).

(13) Install thru bolts (10).

(14) Remove wire, inserted in step 3-5d. (11).

NOTE

Perform steps in paragraph 3-5e(1) before proceeding with assembly.

(15) Install capacitor and clamp assembly (27), screw (25), washers (26), lockwasher (24) and nut (23). Install nuts (22 and 21).

(16) Install capacitor and clamp assembly (28) and brush lead (15).

(17) Install ventilated cover band (9) with screws (8).

(18) Install all electrical leads that were tagged and disconnected during disassembly in step 3-5b. (2). (See figure 3-4. )

(19) Install washer (5), fuse holder (3), and nut (4). Resolder leads to fuse holder.

(20) Install fuse (7) and cap (6).

NOTE

Install test leads as indicated in e.(2) below.

NOTE

Complete testing of alternator sub-paragraph e. (2) below prior to completing assembly.

e. Testing.

(1) Manufacture test leads as follows:

(a) From No. 8 or No. 10 insulated wire, cut three lengths, one 10 inches long and two 5 inches long.

(b) Strip both ends of all three leads and tin with solder.

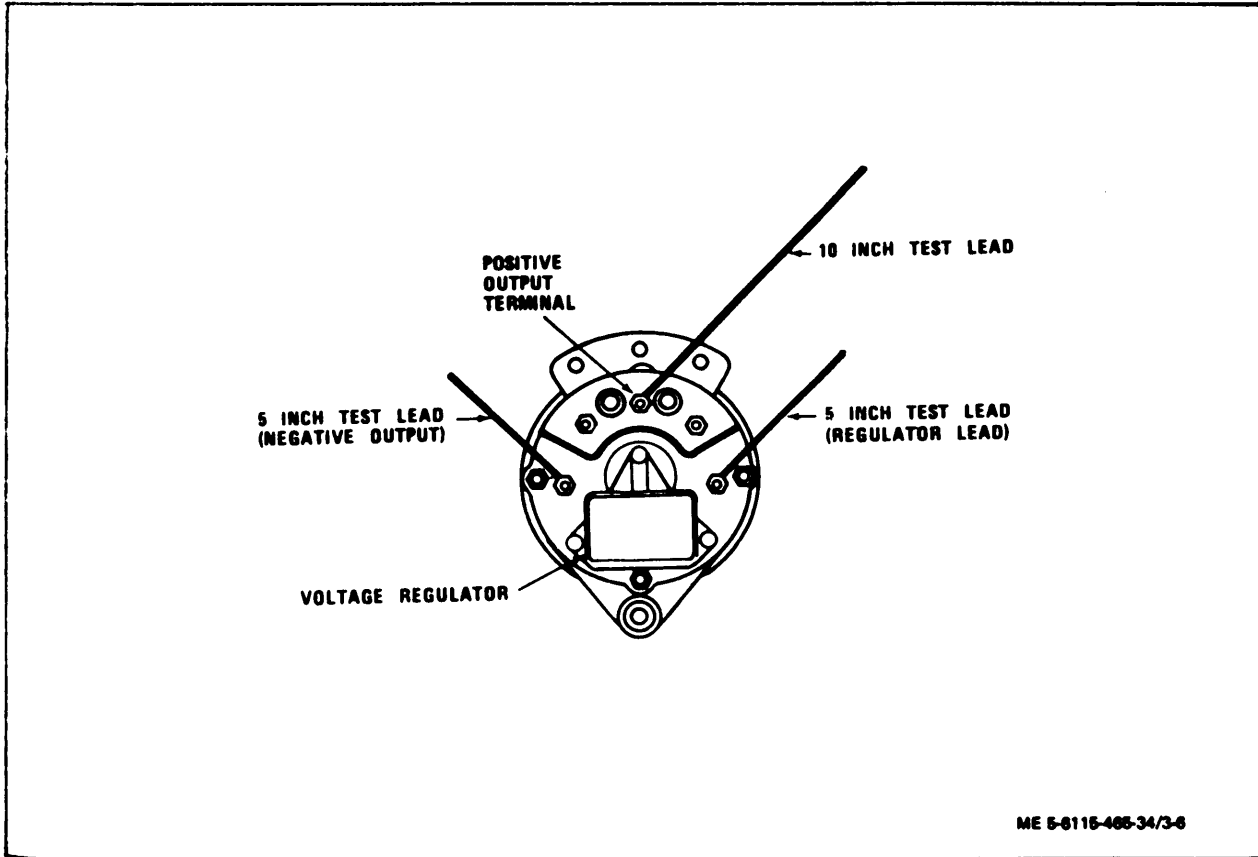

Figure 3-6. Alternator Test Leads Installation

(c) Attach a 1/4 inch ring terminal to one end of the 10 inch lead.

(d) Attach a No. 10 ring terminal to one end of each 5 inch lead.

(2) Install test leads as follows:

(a) Attach test leads as shown in figure 3-6. Pass the free end of each lead through the ventilated band cover (9, figure 3-4).

(b) Install regulator and cover assembly (2) and secure with screws (1).

(3) Check alternator total circuit voltage as follows:

(a) Install alternator in test circuit as shown in figure 3-7.

**NOTE**

The test circuit is identical to the alternator installation circuit. If an operational generator set is available, the alternator may be installed on it for testing.

**NOTE (CONT)**

(Refer to the Operator and Organizational Maintenance Manual for installation instructions.

(b) With switch open, compare voltage readings at V1 and V2. The readings should be identical

**NOTE**

While checking voltage at V2, check to see if the reading varies when the cable or the connector plug on the alternator cover assembly is disturbed. This could indicate inadequate test connections which must be corrected before proceeding with the tests.

(c) If voltage at V2. is low or zero, the alternator positive and negative output circuits must be tested as indicated in steps (4) and (5) below.

(d) If voltage readings at V1 and V2 are identical, proceed with alternator output and voltage protector test in step (10) below.

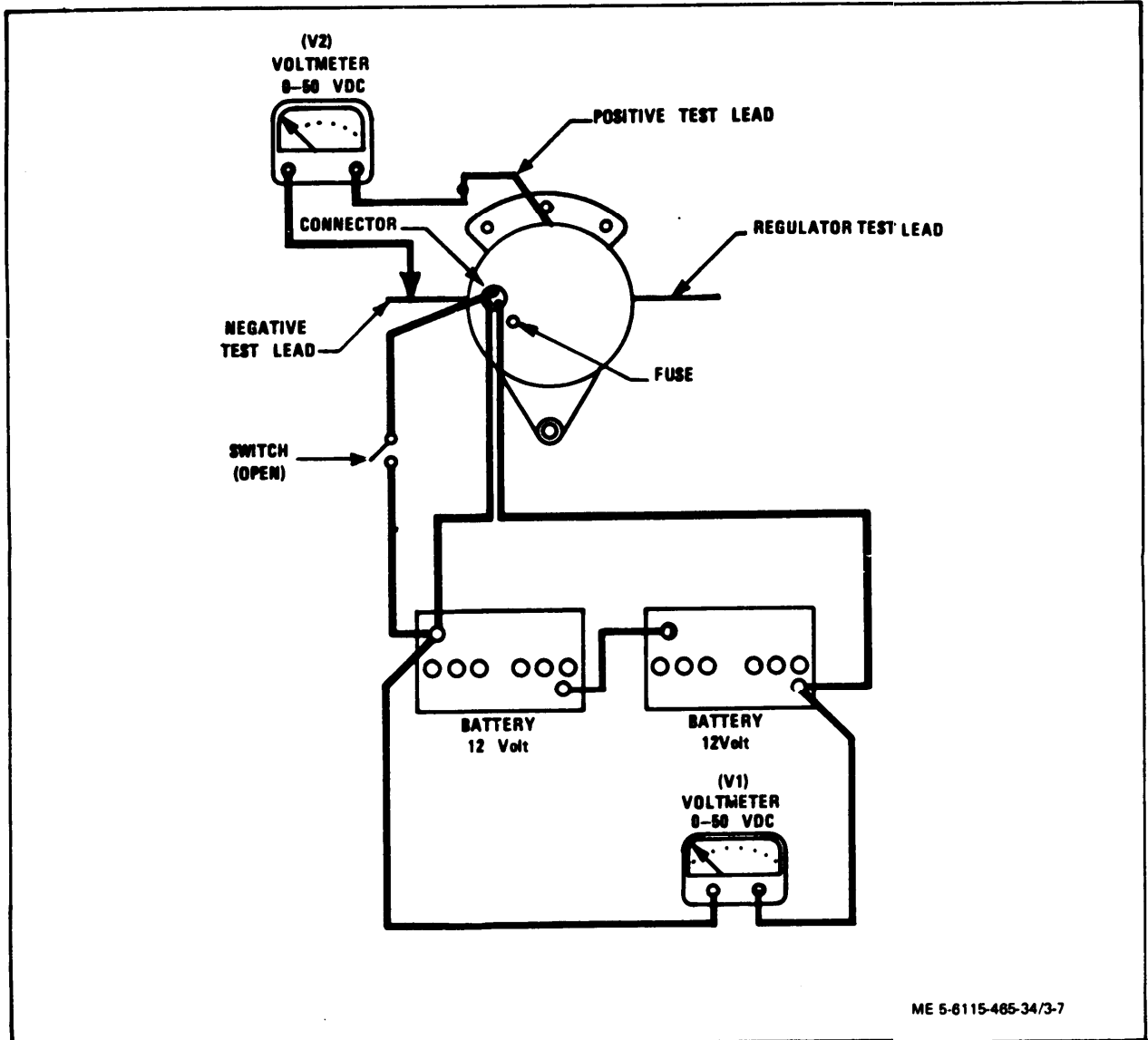

Figure 3-7. Total Circuit Voltage Test

(4) Test alternator positive output circuit as follows:

(a) Check voltage at V3 as shown in figure 3-8.

(b) If voltage is zero, check fuse (11, figure 3-4).

(c) If voltage is greater than zero, but below voltage V1 in figure 3-7, check for poor circuit conditions between battery positive terminal and alternator positive output terminal.

(d) Correct any discrepancies before proceeding with operational tests.

(e) If voltage indicated is equal to voltage V1, test alternator negative output circuit as directed in step (5) below.

(5) Test alternator output circuit as follows:

(a) Check voltage V4 as indicated in figure 3-9.

(b) If voltage is below voltage at V1 (figure 3-7), check for inadequate circuit conditions between

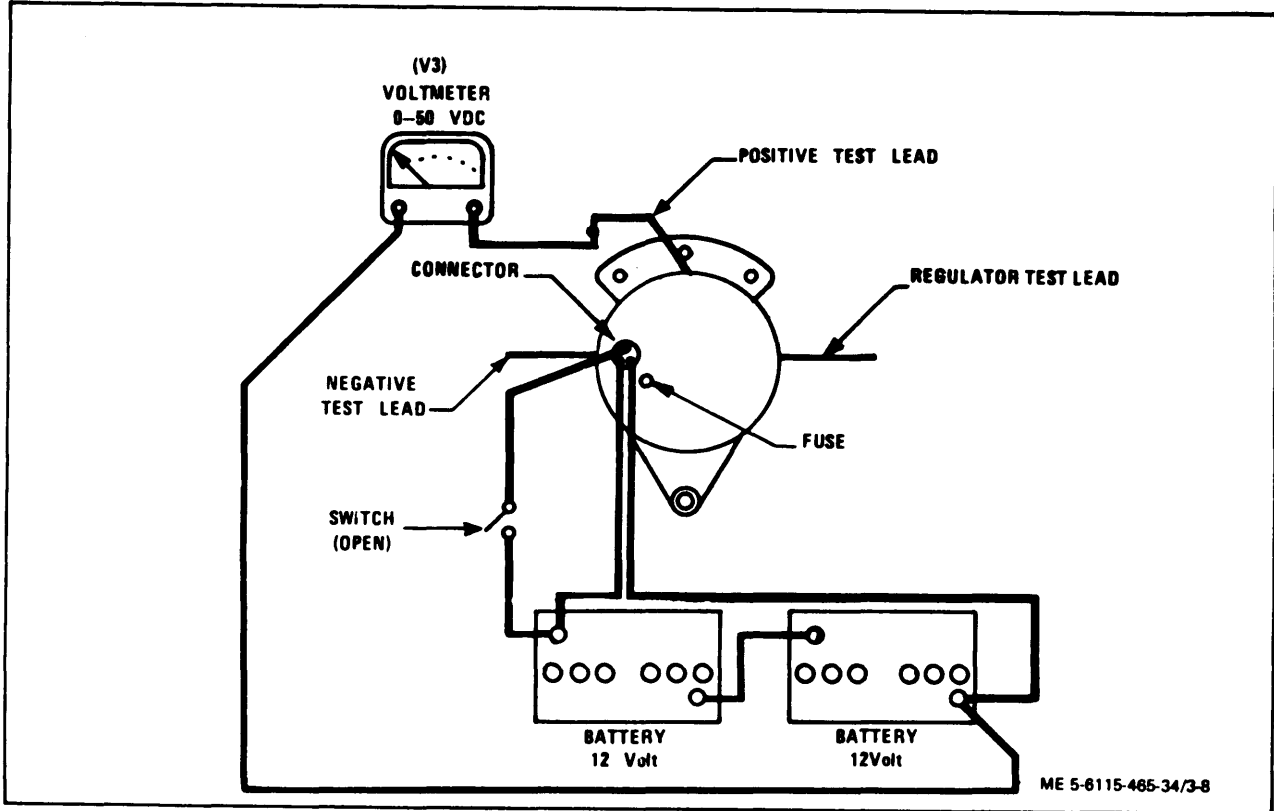

Figure 3-8. Alternator Positive Output Circuit Test

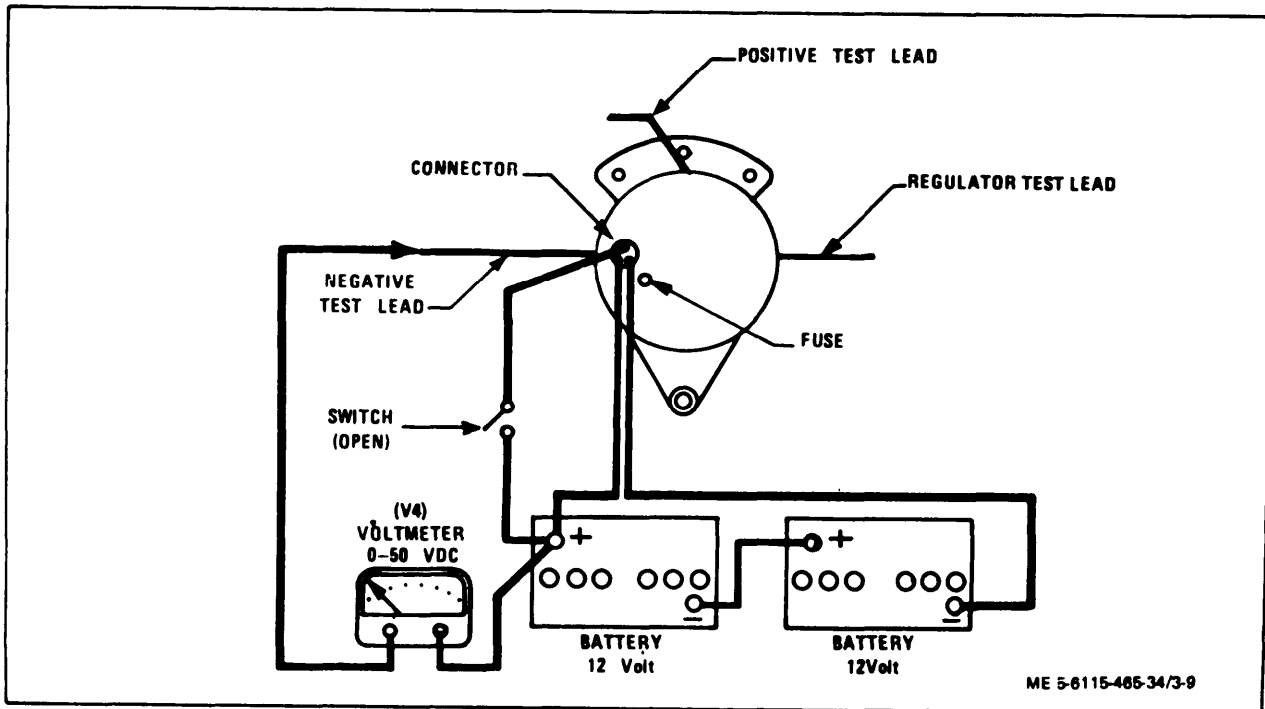

Figure 3-9. Alternator Negative Output Circuit Test

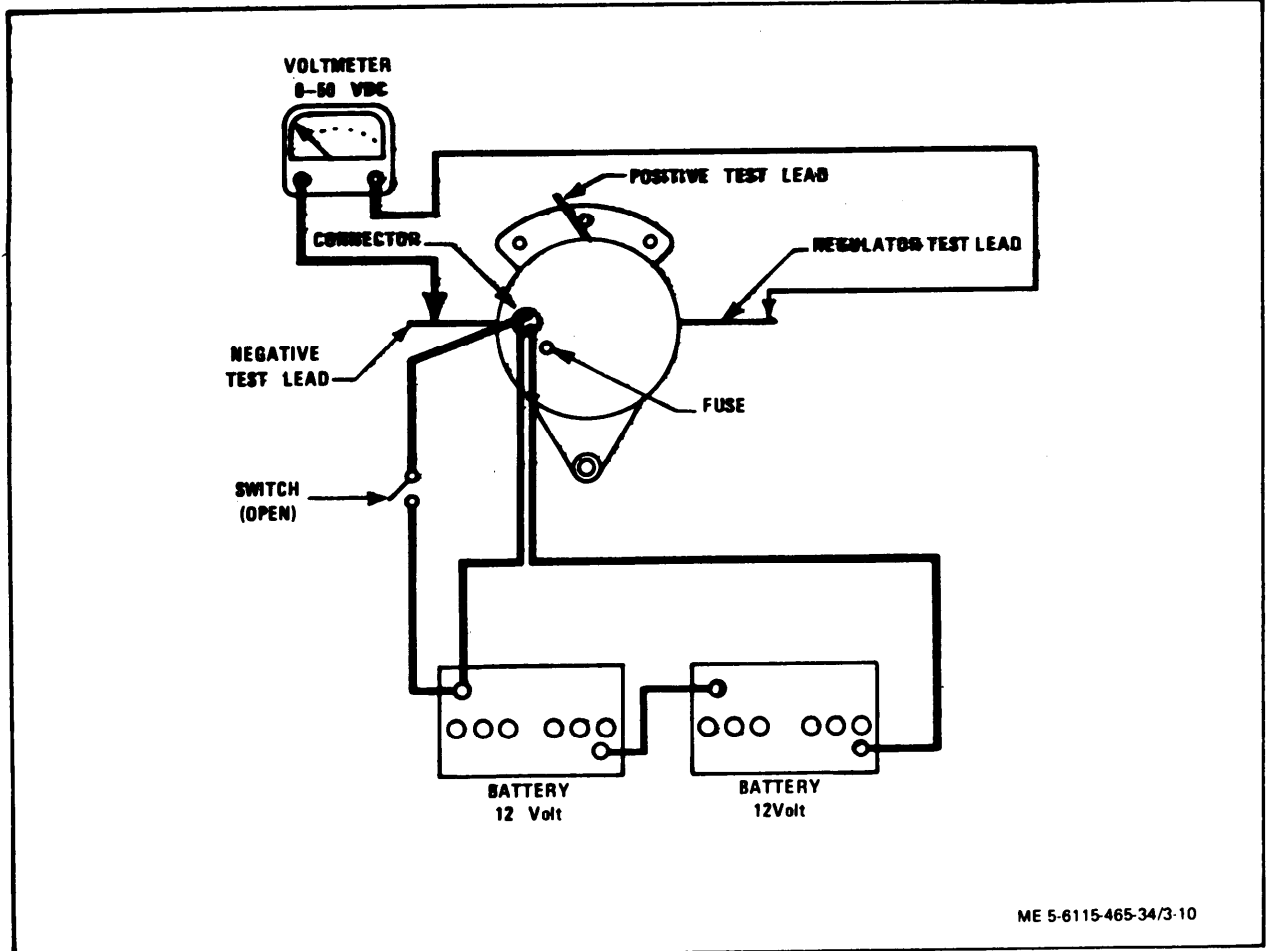

Figure 3-10. Excitation Voltage Test

battery negative terminal and alternator negative output-terminal.

(c) Correct any discrepancies before conducting operational tests.

(6) Conduct excitation voltage test as follows:

(a) With voltmeter connected as in figure 3-10, close switch.

(b) Voltmeter should indicate  $3.5 \pm 0.2$  Vdc.

(c) If voltmeter indicates zero volts, test voltage regulator as directed in step (8) below.

(d) If voltmeter indication is greater than 3.7 Vdc, test for open circuit of alternator field (rotor) as directed in step (9) below.

(e) If voltmeter indication is as specified, proceed with voltage regulator, alternator output,

and voltage protector test as outlined in step (10) below.

(8) Test for faulty alternator voltage regulator as follows:

(a) Remove screws (1, figure 3-4) and cover assembly (2).

(b) Disconnect voltage regulator by disconnecting and tagging the red, green and black leads.

(c) Disconnect and tag the blue and yellow output leads.

(d) Install a jumper from the GND terminal to brush terminal as shown in figure 3-11.

(e) Install alternator in test circuit as shown in figure 3-11.

**NOTE**

A means of rotating the alternator at 2000 to 3000 RPM must be provided. This test can be performed with the alternator installed on an operational generator set, and operating the set at rated frequency.

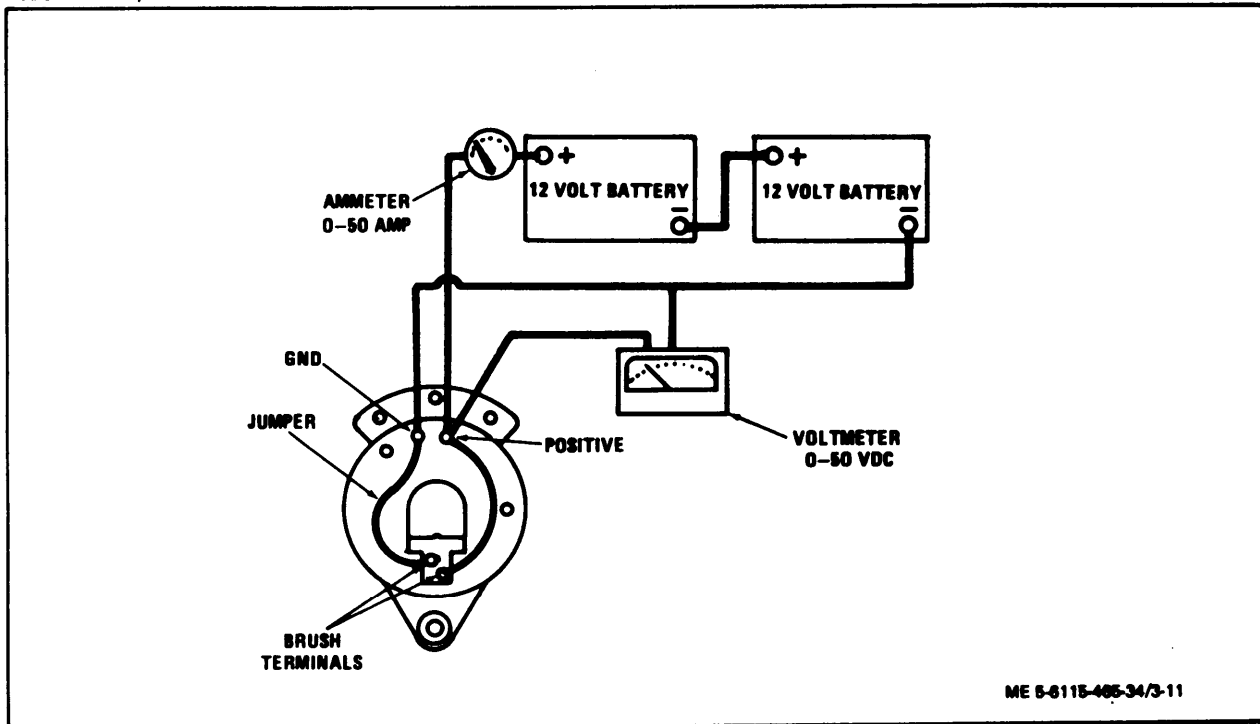

Figure 3-11 Faulty Voltage Regulator Circuit Test

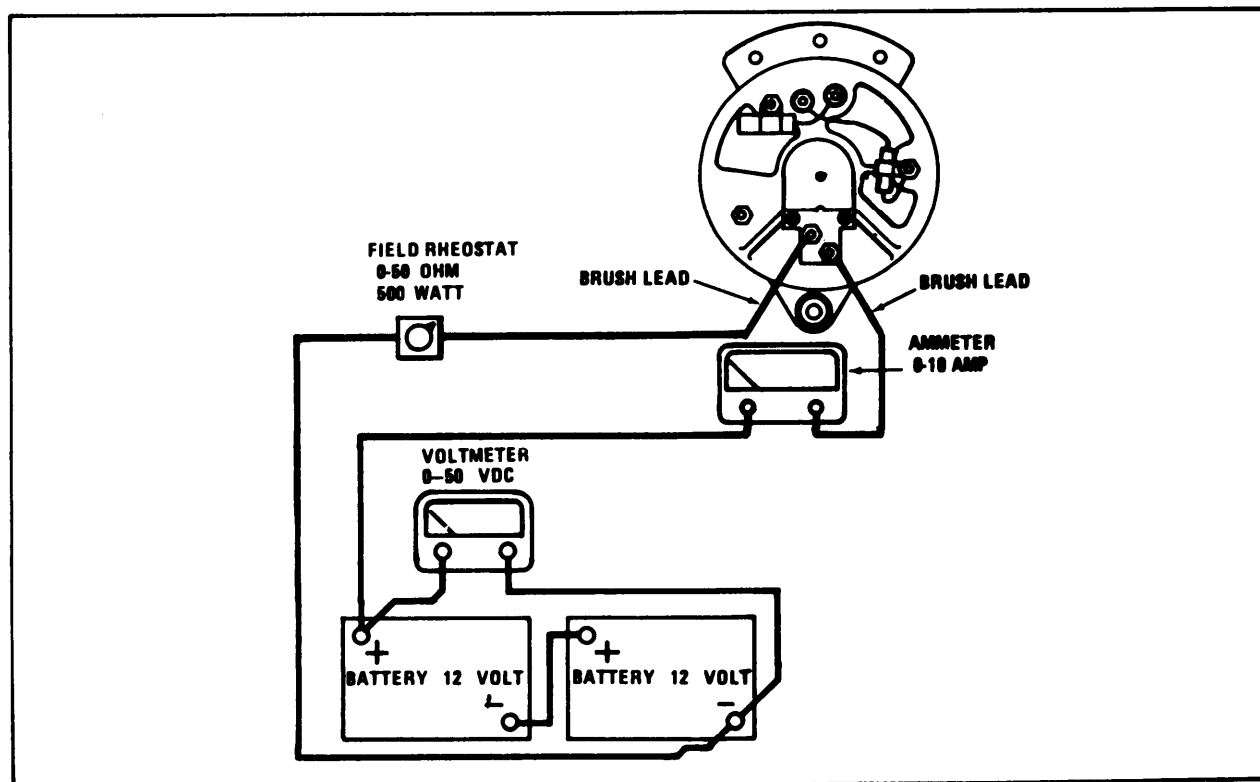

Figure 3-12. Field Current Test

(f) With the alternator rotating at 2500 RPM the voltmeter should indicate 24 to 28 volts and the ammeter should indicate 32 to 35 amperes.

(g) If the alternator tests satisfactorily, this indicates that the voltage regulator was faulty.

(h) If the alternator does not test satisfactorily, this indicates that the voltage regulator is good and the trouble is in the alternator.

(i) If the regulator is faulty, remove the jumper (figure 3-11) and install a new regulator and cover assembly using the tagged leads on the old cover assembly as a guide when making connections.

(9) **Conduct** field current test as follows:

**CAUTION**

Rheostat must be set in maximum resistance position to protect the ammeter in the event the field circuit is short circuited.

(a) Install alternator in test circuit as shown in figure 3-12.

(b) Slowly reduce field rheostat resistance while observing ammeter and voltmeter.

(c) When field rheostat reaches zero ohms, ammeter should indicate 3.0 to 3.5 amperes with voltmeter indicating 24 Vdc.

(d) **If** current is not as specified, check for poor connections and inadequate brush contact.

(10) Conduct alternator output and voltage protector test as follows:

(a) Install alternator in test circuit shown in figure 3-13.

**NOTE**

If alternator is not installed on generator set for this test, a means of rotating the alternator at 2,000 to 3,000 RPM must be provided.

(b) Adjust the drive device to provide 2500 RPM.

(c) Note the voltmeter indication. Nominal voltage should be 28 Vdc  $\pm$  0.3Vdc

(d) If voltage is not as specified, adjust the voltage regulator rheostat on the alternator rear cover.

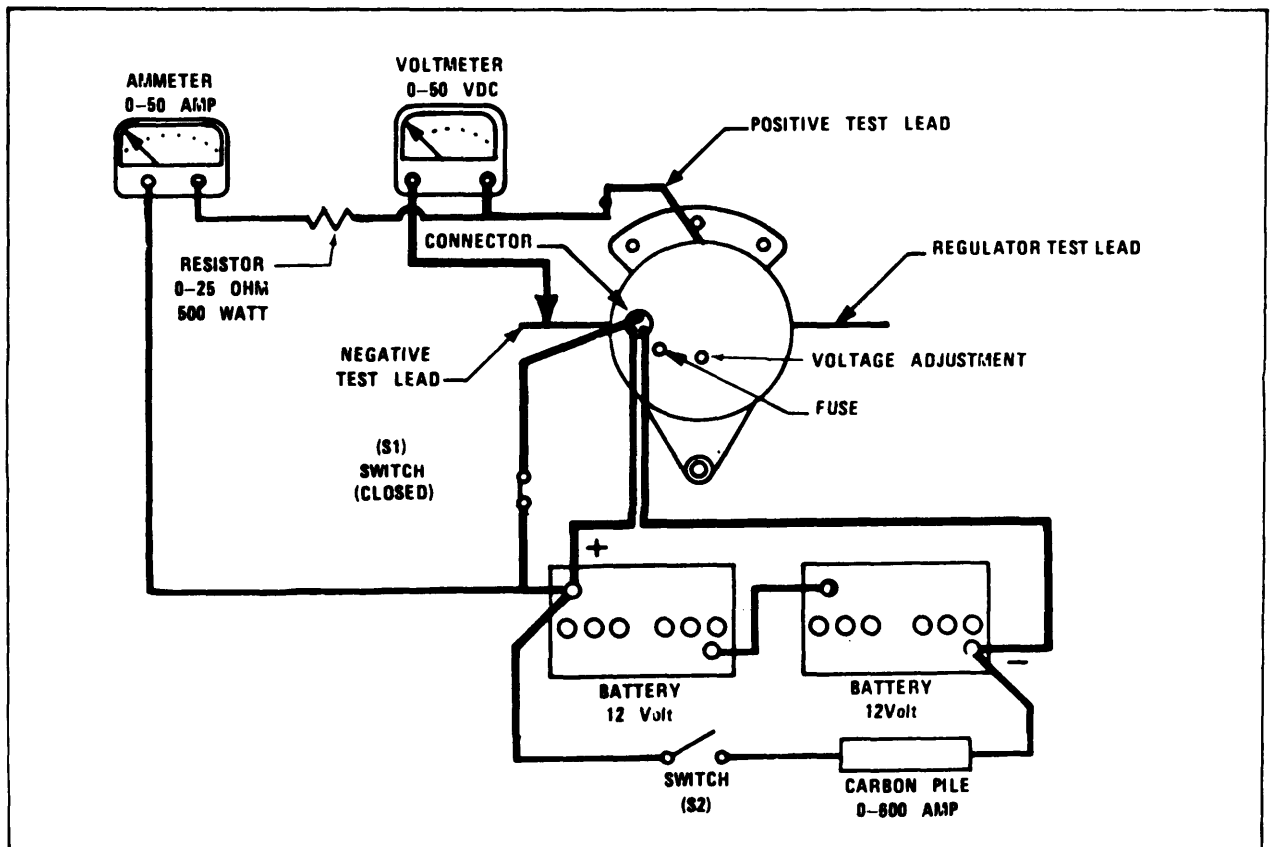

Figure 3-13. Output and Voltage Protector Test

(e) Close switch (S2) to put carbon pile load on the batteries.

(f) Check ammeter and voltmeter indications. Nominal current output should be 20-25 amperes with charging voltage exceeding 25.0 Vdc.

**CAUTION**

Open switch (S2) immediately after current test to avoid discharging the batteries.

(g) If nominal voltage cannot be obtained, disassemble alternator and correct difficulty.

(h) Remove alternator from test circuit, remove rear cover assembly and disconnect test leads.

(i) Reinstall rear cover assembly and fuse.

f. Installation. Refer to Operator and Organizational Maintenance Manual for battery charging alternator installation instructions.

3-6. SPEED SWITCH.

a. Removal. Refer to Operator and Organizational Maintenance Manual for speed switch removal instructions.

b. Disassembly.

(1) Remove screws (1, figure 3-14) to remove rotor assembly (2) from electronics assembly (12).

(2) Remove rotor cap (3), cotter pin (4), and rotor (5).

(3) Remove retaining rings (6 and 7), bearing (8), shaft (9) and base (10).

c. Cleaning, Inspection, and Repair.

**CAUTION**

Do not submerge the electronics assembly (12) and base assembly (11) in cleaning solvent.

(1) Wipe the exterior of the electronics assembly (12) and base assembly (11) with a clean rag, lightly moistened in cleaning solvent.

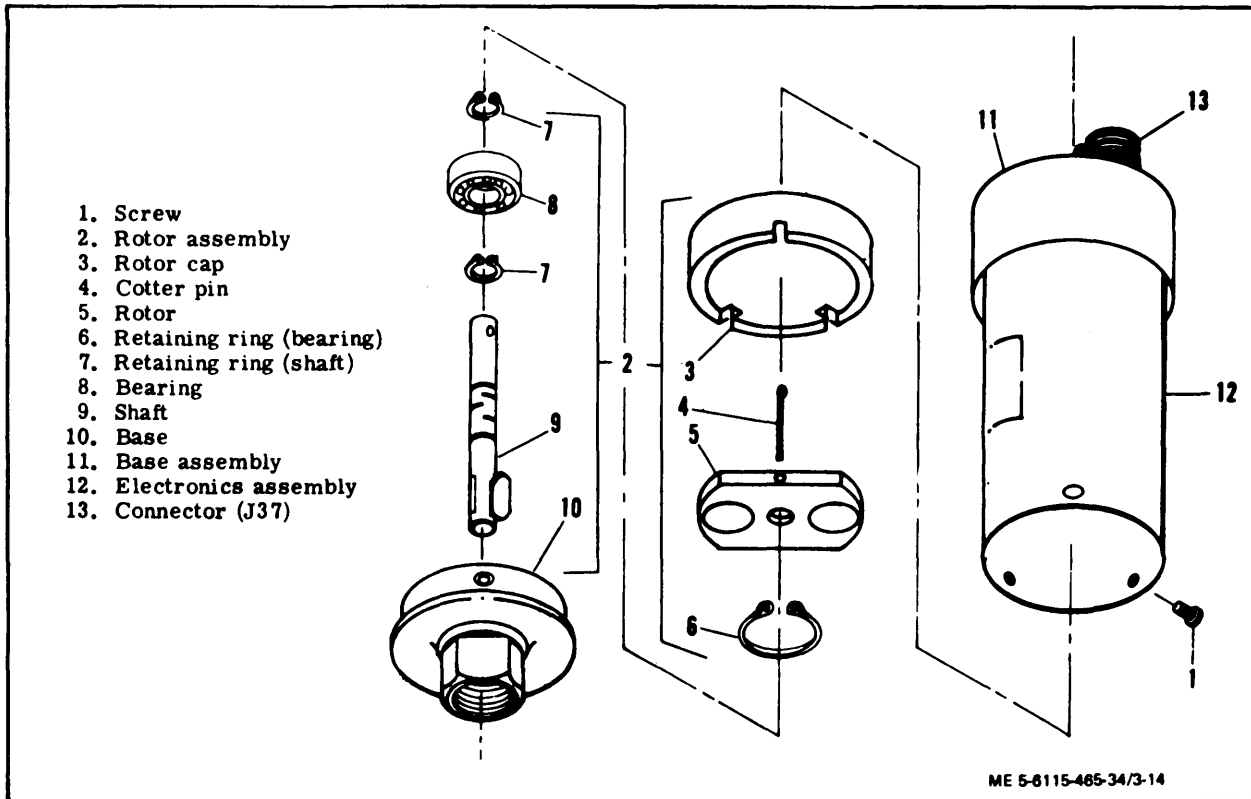

Figure 3-14. Speed Switch, Exploded View



(2) Clean all other parts with cleaning solvent and dry thoroughly.

(3) Inspect base, rotor cap, electronics and base assemblies for cracks, corrosion, or other damage.

(4) Check rotor and shaft for cracks, corrosion, or other damage.

(5) Check the bearing (8) for excessive wear.

(6) Replace any worn or defective parts.

NOTE

There are no repair procedures for the electronics and base assemblies. If this portion of the speed switch is malfunctioning, replace both assemblies as a unit.

c. Test Equipment. The following test equipment will be required to properly test the speed switch.

(1) Tachometer test stand or speed switch tester with O. 187 tach takeoff fitting, capable of operation up to 1225 RPM.

(2) 24 Vdc power supply.

(3) VOM suitable for measuring continuity and 24 volts dc.

(4) Mating connector and cable for MS3102R-18-1P connector.

d. Testing. Refer to figure 3-15 for schematic diagram of pins to be used during test, and perform the following procedures.

(1) Screw the tachometer fitting onto the test stand.

(2) Attach the connector and cable to J37 of the speed switch.

(3) Connect 24 volts dc to pins E, G and I with the polarity indicated in the test circuit.

(4) Using the VOM test for the conditions listed below:

Element No. 1:

Pins A & B . . . . . Continuity  
 Pins A & C . . . . . open circuit

Element No. 2:

Pin D . . . . . 0 volts dc to ground

Element No. 3:

Pins F & J . . . . . open circuit  
 Pin H . . . . . 24 volts dc to ground

(5) Connect the VOM to read continuity between pins A and B.

(6) Slowly bring up shaft speed of the tester. At 290 to 310 rpm Element No. 1 should trip causing an open circuit to appear between pins A and B.

(7) After Element 1 has tripped, check with the VOM for continuity between pins A and C.

(8) Proper tripping of Element No. 1 is indicated by meeting the conditions of steps (4), (6) and (7).

(9) Connect the VOM to read voltage on pin D with respect to ground.

(10) Slowly increase the tester shaft speed while monitoring the VOM. When Element No. 2 trips, the reading will go from 0 volts to 24 volts. Trip speed for Element No. 2 (50/60 Hz) is 590 to 610 RPM. Trip speed for Element No. 2 (400 Hz) is 825 to 850 RPM.

(11) Continue increasing shaft speed while monitoring pin H for voltage. It should be at 24 volts, dropping to 0 volts when the third element trips. Trip speed for Element No. 3 is 1200 to 1225 RPM.

(12) After Element No. 3 has tripped, connect the VOM between pins F and J to check for continuity. Continuity should exist after Element No. 3 has tripped.

(13) Slowly decrease shaft speed while monitoring pin D with the VOM for voltage. There should be 24 volts present, dropping to 0 volts when Element No. 2 resets. "Reset speed", for Element No. 2, should be no more than 100 RPM below the trip speed noted in Step (10).

(14) Continue decreasing shaft speed while measuring for continuity between pins A and C with the VOM. Continuity should exist between these two pins until Element No. 1 resets, then an open circuit should exist. Reset speed for Element No. 1 should be no more than 100 RPM below the trip speed noted in step (6).

(15) Decrease shaft speed to 0 RPM. Monitor pin H for voltage with the VOM. Element No. 3 should still remain in the tripped condition, resulting in 0 volts on pin H, and continuity between pins F and J.

(16) Depress and release the reset switch, S1, on the speed switch. Pin H should now read 24 volts on the VOM.

e. Assembly. Assemble speed switch in reverse order of disassembly.

f. Installation Refer to Operator and Organizational Maintenance Manual and install speed switch in reverse order of removal.

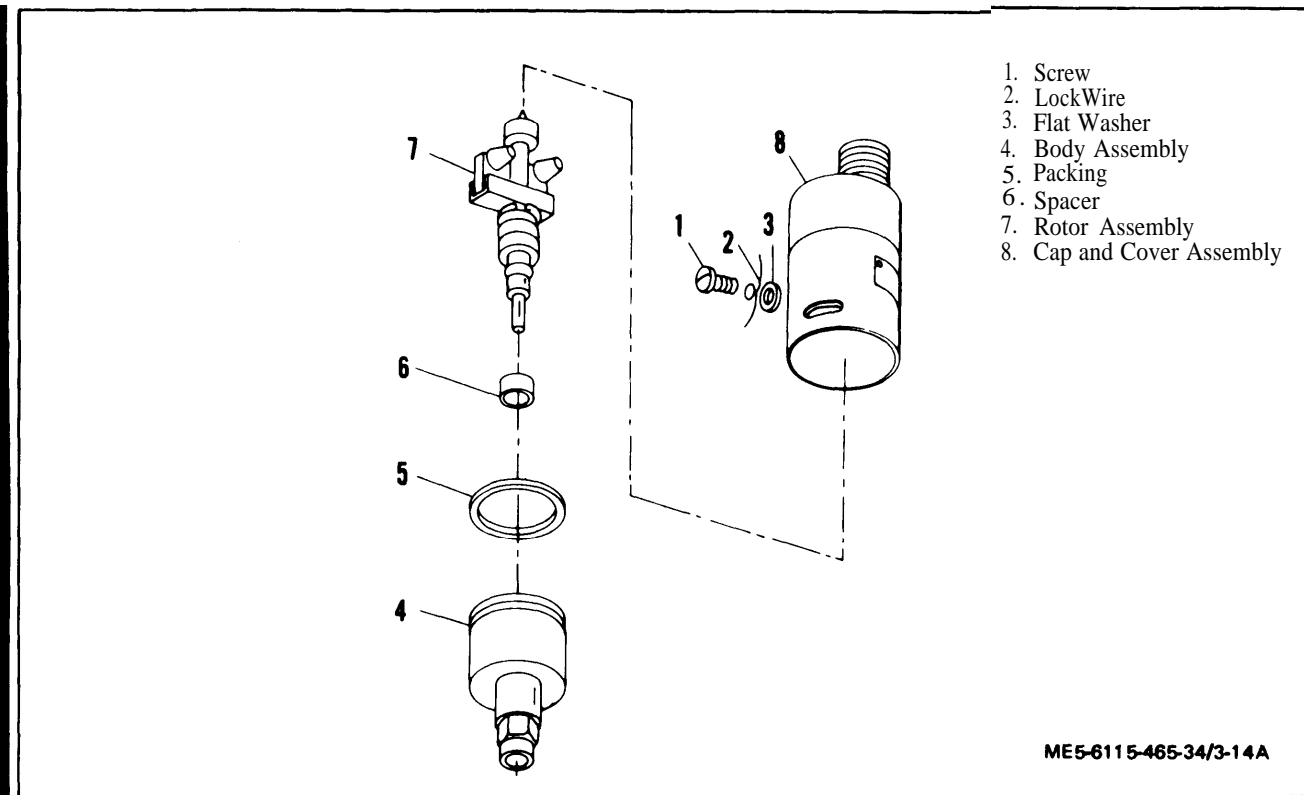

Figure 3-14.1 Speed Switch. Exploded View Effective with Serial No. RZ70001 and KZ027251 thru KZ027520

3-6.1. **SPEED SWITCH** (Effective with serial number RZ70001 and KZ00001 thru KZ02752).

a. Removal. Refer to Operator and Organizational Maintenance Manual for speed switch removal instructions.

b. Disassembly.

(1) Remove screws (1, figure 3-14.1), lock wire (2) and flat washers (3).

(2) Remove body assembly (4), packing (5), spacer (6) and rotor assembly (7) from cap and cover assembly (8),

c. Cleaning, Inspection, and Repair.

**CAUTION**

Do not submerge the cap and cover assembly (8) in cleaning solvent.

(1) Wipe the exterior of the cap and cover assembly (8) with a clean rag moistened in cleaning solvent.

(2) Clean all other parts with cleaning solvent and dry thoroughly,

(3) Inspect cap and cover, body assembly, and rotor

assembly for cracks, corrosion, or other damage.

(4) Replace any worn or defective parts.

**NOTE**

There are no repair procedures for the cap and cover assembly,

d. Test Equipment. The following test equipment will be required to properly test the speed switch.

(1) Tachometer test stand or speed switch tester with 0.187 tach takeoff fitting, capable of operation up to 1225 RPM.

(2) 24 Vdc power supply.

(3) VOM suitable for measuring continuity and 24 volts dc.

(4) Mating connector and cable for MS3102R-18-1P connector.

e. Testing. Refer to figure 3-15 for schematic diagram of pins to be used during test, and perform the following procedures.

- (1) Screw the tachometer fitting onto the test stand.
- (2) Attach the connector and cable to J37 of the speed switch.
- (3) Connect 24 volts dc to pins E, G and 1 with the polarity indicated in the test circuit.
- (4) Using the VOM test for the conditions listed below:

Element No. 1:

Pins A&B ..... continuity  
Pins A&C ..... open circuit

Element No. 2:

Pin D ..... 0 volts dc to ground

Element No. 3:

Pins F&J ..... open circuit  
Pin H ..... 24 volts dc to ground

- (5) Connect the VOM to read continuity between pins A and B.
- (6) Slowly bring up shaft speed of the tester. At 290 to 310 rpm Element No. 1 should trip causing an open circuit to appear between pins A and B.
- (7) After Element I has tripped, check with the VOM for continuity between pins A and C.
- (8) Proper tripping of Element No. I is indicated by meeting the conditions of steps (4), (6) and (7).
- (9) Connect the VOM to read voltage on pin D with respect to ground.

(10) Slowly increase the tester shaft speed while monitoring the VOM. When Element No. 2 trips, the reading will go from 0 volts to 24 volts. Trip speed for Element No. 2 (50/60 Hz) is 590 to 610 RPM. Trip speed for Element No. 2 (400 Hz) is 825 to 850 RPM.

(11) Continue increasing shaft speed while monitoring pin H for voltage. It should be at 24 volts, dropping to 0 volts when the third element trips. Trip speed for Element No. 3 is 1200 to 1250 RPM.

(12) After Element No. 3 has tripped, connect the VOM between pins F and J to check for continuity. Continuity should exist after Element No. 3 has tripped.

(13) Slowly decrease shaft speed while monitoring pin D with the VOM for voltage. There should be 24 volts present, dropping to 0 volts when Element No. 2 resets. "Reset Speed" for Element No. 2, should be no more than 100 RPM below the trip speed noted in Step (10).

(14) Continue decreasing shaft speed while measuring for continuity between pins A and C with the VOM. Continuity should exist between these two pins until Element No. 1 resets, then an open circuit should exist. Reset speed for Element No. 1 should be no more than 100 RPM below the trip speed noted in step (6).

(15) Decrease shaft speed to 0 RPM. Monitor pin H for voltage with the VOM. Element No. 3 should still remain in the tripped condition, resulting in 0 volts on pin H, and continuity between pins F and J.

(16) Depress and release the reset switch, S1, on the speed switch. Pin H should not read 24 volts on the VOM.

f. Assembly. Assemble speed switch in reverse order of disassembly.

g. Installation. Refer to Operator and Organizational Maintenance Manual and install speed switch in reverse order of removal.

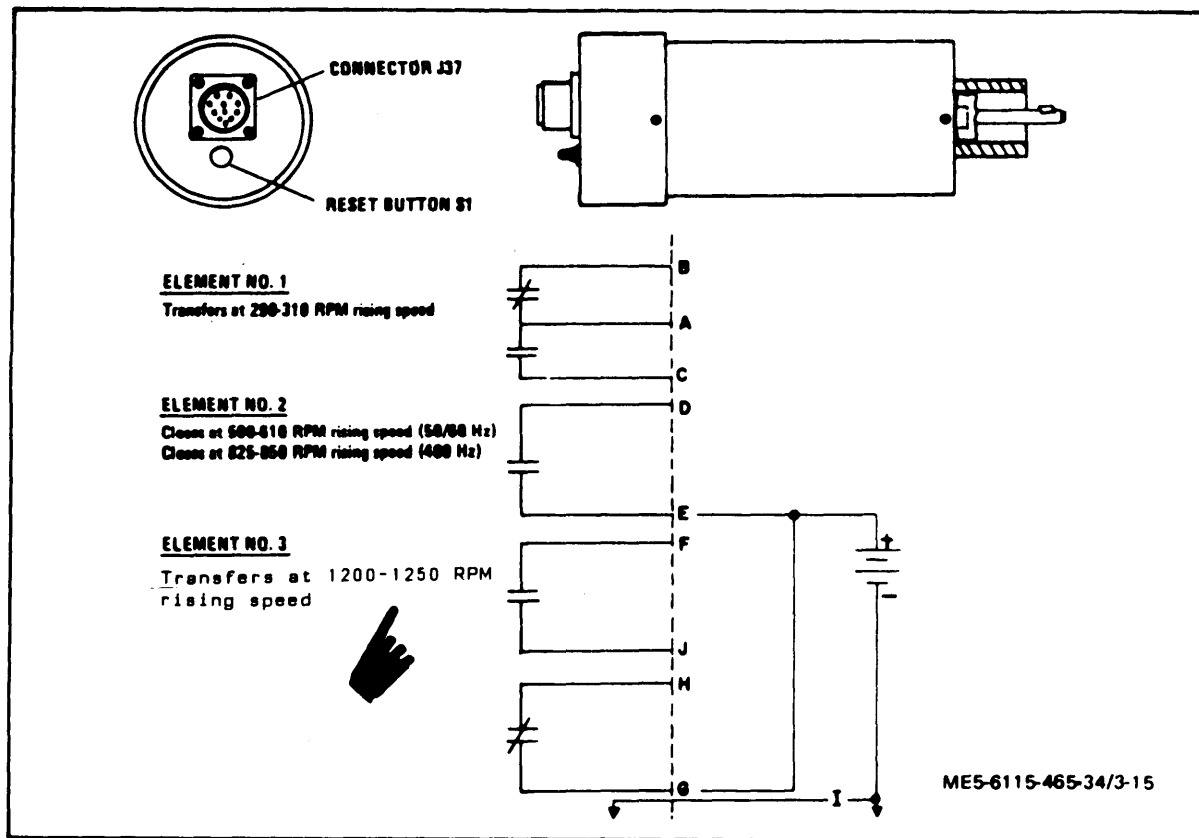

Figure 3-15. Speed Switch Test Points

3-7. COOLANT TEMPERATURE TRANSMITTER.

Refer to the Operator and Organizational Maintenance Manual for coolant temperature transmitter maintenance procedures.

3-8. OVERTEMPERATURE SWITCH.

Refer to the Operator and Organizational Maintenance Manual for overtemperature switch maintenance procedures.

3-9. OIL PRESSURE TRANSMITTER.

Refer to the Operator and Organizational Maintenance Manual for oil pressure transmitter maintenance procedures.

3-10. LOW OIL PRESSURE SWITCH.

Refer to the Operator and organizational Maintenance Manual for low oil pressure switch maintenance procedures.

3-11. DAY TANK FUEL LEVEL AND LOW FUEL CUTOFF SWITCH.

Refer to the Operator and Organizational Maintenance Manual for day tank fuel level and low fuel cutoff switch maintenance procedures.

3-12. FUEL SOLENOID VALVE.

Refer to the Operator and Organizational Maintenance Manual for fuel solenoid valve maintenance procedures.

3-13. ENGINE WIRING HARNESS ASSEMBLY.

a. Removal Refer to the Operator and Organizational Maintenance Manual for engine wiring harness removal instructions.

b. Cleaning, Inspection, and Repair. Refer to the Operator and Organizational Maintenance Manual for engine wiring harness cleaning, inspection, and repair procedures.



c. Rebuild. If the wiring harness has sustained damage and requires repair or rebuild, refer to figure 3-16 for layout, Identification, and material requirements and appendix A for detailed soldering and replacement

procedures.

d. Installation. Refer to the Operator's and Organizational Maintenance Manual for engine wiring harness installation procedure.

## Section II. ENGINE FUEL SYSTEM

### 3-14. GENERAL

Fuel for generator set operation is supplied from either the integral main fuel main tank or an auxiliary source as determined by the fuel selector valve. Fuel is pumped through the strainer and filter assembly and fuel solenoid valve into into by day tank by two electrically driven fuel transfer pumps. The day tank fuel level and low fuel cutoff switch controls the operation of the fuel transfer pumps and the fuel solenoid valve. Fuel from the day tank is drawn through the secondary fuel filter assembly by the fuel injection pump. This single cylinder, opposed plunger, inlet metering type pump forces a metered amount of fuel under high pressure and in timed sequence to the fuel injection nozzle holders in the engine cylinder head. The nozzle holders spray a metered amount of fuel into each combustion chamber. Unused fuel is returned to the day tank through the fuel return line.

### 3-15. MAIN FUEL TANK.

#### a Removal.

(1) Refer to the Operator's and Organizational Maintenance Manual and accomplish the following:

- (a) Drain the main fuel tank assembly.
- (b) Disconnect fuel lines and fittings from main fuel tank.
- (c) Disconnect fuel vent system from main fuel tank
- (d) Disconnect engine wiring harness from fuel level gauge.
- (e) Remove left and right ventilation doors, ventilation louver panel, and lower cover panels from rear of generator set housing.

(2) Remove main fuel tank (metal) by following the ascending numerical sequence of index numbers 1 through 20 assigned to figure 3-17.

(3) Remove main fuel tank (plastic) by following the ascending numerical sequence numbers 1-17, as per figure 3-17A.

#### b. Cleaning, Inspection, and Repair.

(1) Clean exterior surfaces of fuel tank and other nonmelectrical parts with dry cleaning solvent (Federal specification P-D-680).

(2) Flush interior of fuel tank with an approved solvent.

(3) Inspect fuel tank assembly for cracked or broken welds, dents, leaks, and other damage.

(4) Test fuel level sensor in accordance with instructions provided in Operator and Organizational Maintenance Manual.

(5) Check filler hose for damage or deterioration.

(6) Check all threads for crossing, stripping, and peening.

### WARNING

Steam clean interior of fuel tank for a minimum of 2 hours to remove residual vapors before attempting to repair welds. Serious injury or death may result from failure to observe this warning.

(7) Repair cracked or broken welds and leaks by welding. Refer to Appedix A for detailed instructions.

(8) Repair damaged threads with a thread chaser.

(9) Replace any parts which are extensively damaged.

#### c. Installation.

(1) Install fuel tank (metal) in reverse order of removal procedurcs. Refer to figure 3-17.

### NOTE

Install filler neck hose with vent holes to top and outboard.

(2) Install main fuel tank (plastic) in reverse order of removal procedurcs, as per figure 3-17A.

### NOTE

Install filter neck hose with vent holes to top and outboard.

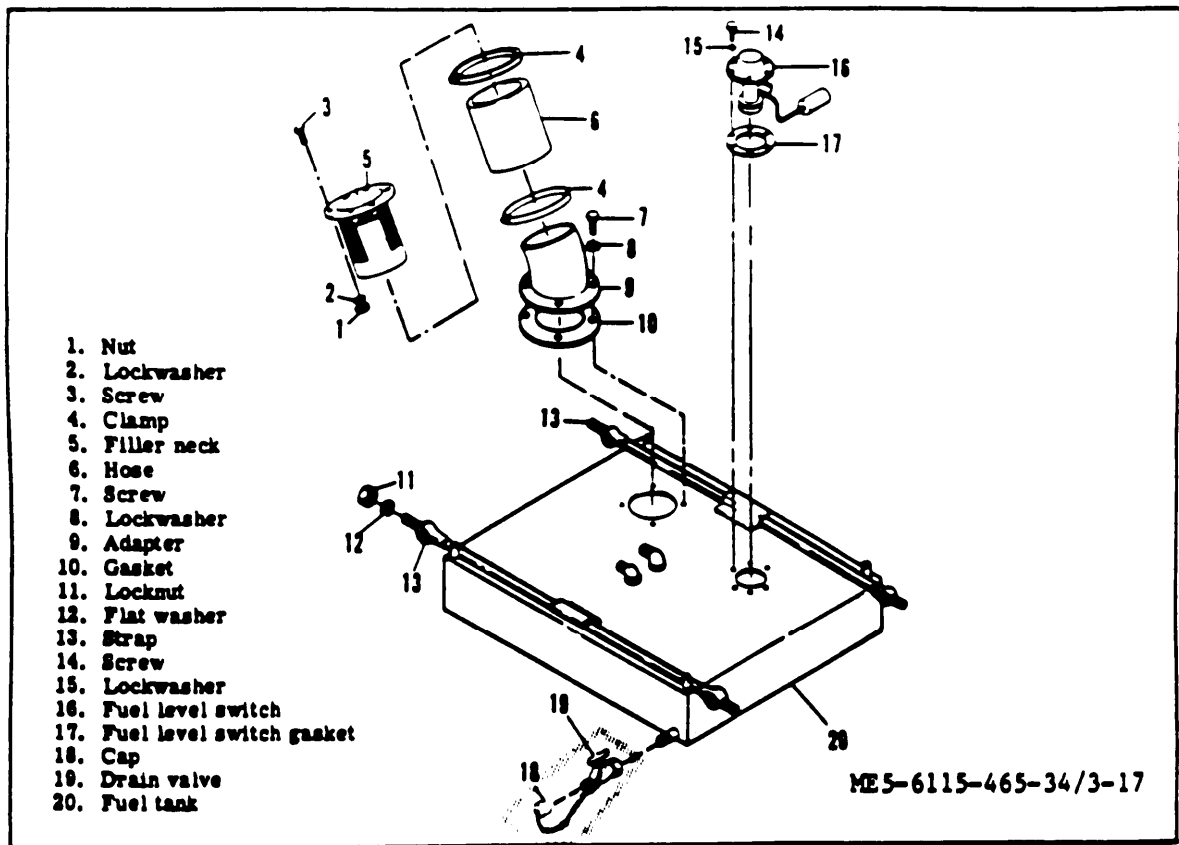

Figure 3-17. Main Fuel Tank (Metal), Removal and Installation

3-16. FUEL TRANSFER PUMPS.

Refer to the Operator's and Organizational Maintenance Manual for fuel transfer pumps maintenance procedures.

3-17. FUEL STRAINER AND FILTER ASSEMBLY.

Refer to the Operator's and Organizational Maintenance Manual for fuel strainer and filter assembly maintenance procedures.

3-18. DAY TANK ASSEMBLY.

a. Removal. Refer to the Operator and Organizational Maintenance Manual for day tank assembly removal instructions.

b. Cleaning, Inspection, and Repair.

(1) Clean exterior surfaces with dry cleaning solvent (Federal Specification P-D-680) and dry with filtered compressed air.

(2) Flush interior of day tank with an approved solvent.

(3) Inspect day tank assembly for cracked or broken welds, dents, and damaged threads.

(4) Check interior of tank for scale formation and hardened sediment deposits.

(5) Test for leaks as follows:

(a) Plug all openings except one.

(b) Install a firing and attach a compressed air line to the unplugged opening.

(c) Submerge day tank in a container of water and apply 5 psig air pressure.

(d) Check for bubble formations which will indicate leakage.





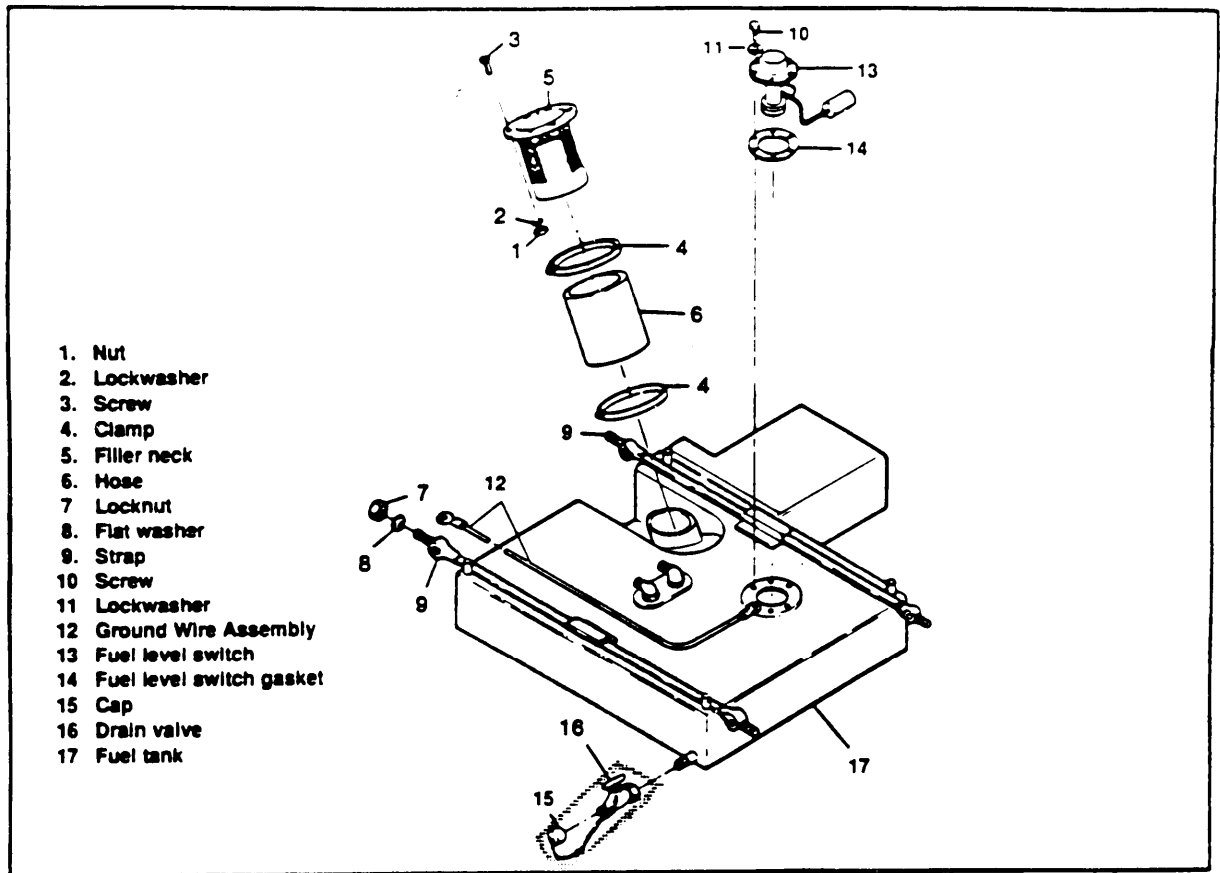

1. Nut
2. Lockwasher
3. Screw
4. Clamp
5. Filler neck
6. Hose
7. Locknut
8. Flat washer
9. Strap
10. Screw
11. Lockwasher
12. Ground Wire Assembly
13. Fuel level switch
14. Fuel level switch gasket
15. Cap
16. Drain valve
17. Fuel tank

Figure 3-17A. Main Fuel Tank (Plastic), Removal and Installation

**WARNING**

Steam clean interior of day tank a minimum of 2 hours to dissipate residual fuel vapors before attempting to repair welds. Serious injury or death may result from failure to observe this warning.

(6) Repair cracked or broken welds and leaks by welding.

(7) Repair damaged threads with a thread chaser,

d. Installation. Install day tank in reverse order of removal procedures.

3-19. **SECONDARY FUEL FILTER ASSEMBLY.**

Refer to the Operator and Organizational Maintenance Manual for secondary fuel filter assembly maintenance procedures.

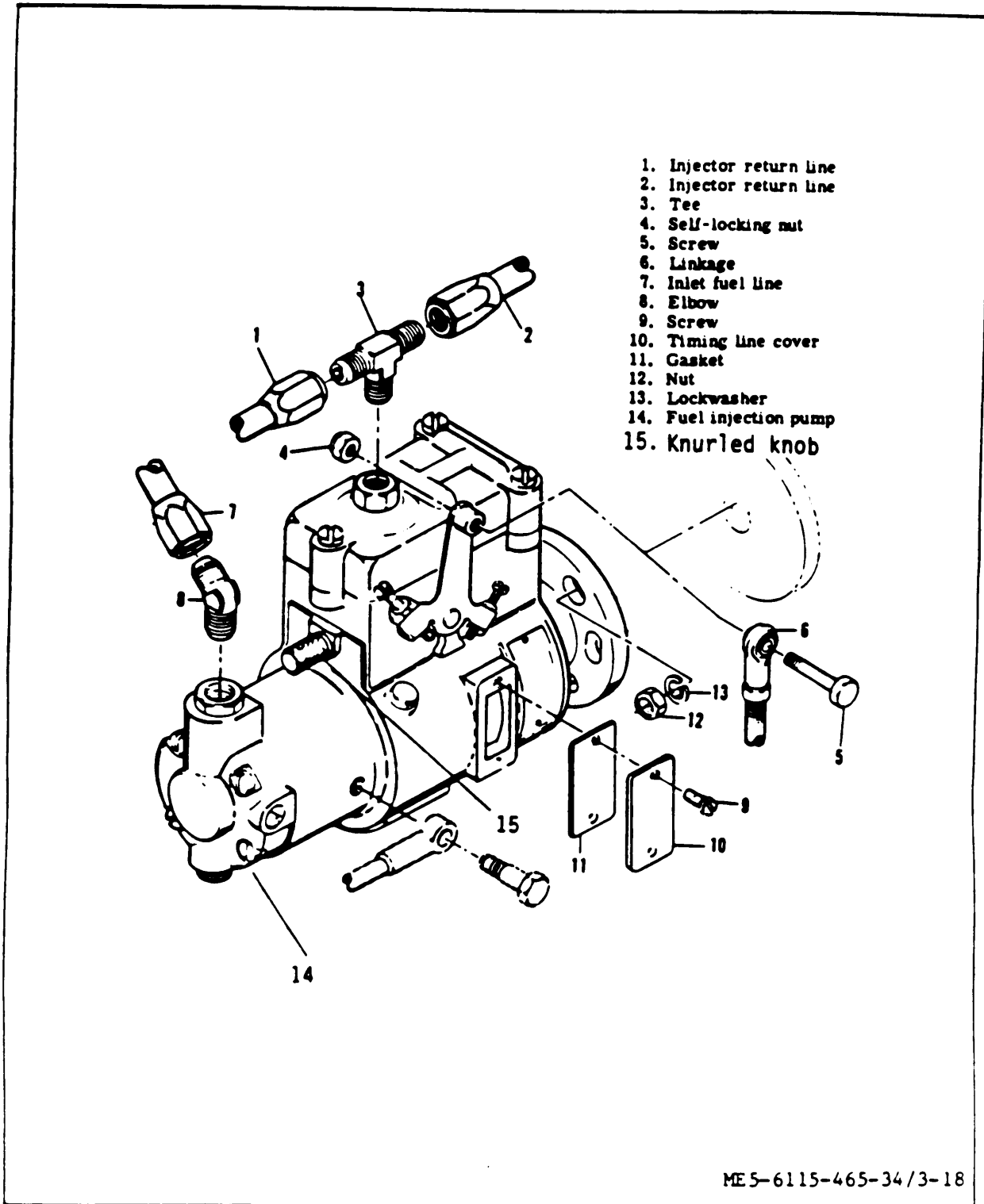

Figure 3-18. Fuel Injection Pump Assembly, Removal and Installation

### 3-20. FUEL INJECTION PUMP ASSEMBLY.

a. General. The Roosa Master Fuel Injection Pump is mounted on the timing gear case and is gear driven through an idler gear arrangement by the crankcase gear. The end thrust of the fuel injection pump gear and shaft is controlled by a spring loaded thrust button located in the inspection cover on the timing gear housing cover. It is advisable when removing or installing the fuel injection pump that the gear housing inspection cover be removed from the timing gear cover to relieve the spring tension of the thrust button. The fuel injection pump attaching flange holes are elongated to permit accurate adjustment of the fuel pump timing.

b. Removal.

#### CAUTION

Thoroughly clean the fuel injection pump prior to removal. Cap or plug all fittings and lines to prevent dirt from entering the pump and fuel system.

(1) Refer to the Operator and Organizational Maintenance Manual and drain the day tank assembly.

(2) Disconnect injector return lines (1 and 2, figure 3-18) and remove tee (3).

(3) On precise sets, remove self-locking nut (4) and screw (5) to disconnect hydraulic actuator linkage (6). On utility sets disconnect the manual speed control.

#### NOTE

When fuel pump is removed from the engine for repair, the throttle lever should be tied in the wide open position while it is in transit or storage. This prevents the governor weights from lodging inside the pump housing.

(4) Disconnect inlet fuel line (7) and remove elbow (8).

(5) Refer to the Operator and Organizational Maintenance Manual and disconnect fuel injector lines.

(6) Remove screws (9), timing line cover (10), and gasket (11).

(7) Using a suitable wrench on the crankshaft pulley, bar the engine over in the direction of rotation until the timing line on the governor retainer hub aligns with the timing line on the pump cam.

(8) Remove nuts (12) and lockwashers (13).

#### CAUTION

Do not allow the pump to 'cock' as it is removed, as damage to the pilot tube will result.

(9) Carefully slide fuel injection pump (14) from the timing gear housing.

c. Disassembly. Disassemble the fuel injection pump in the ascending sequence of item numbers assigned to figure 3-19 while observing the following:

#### NOTE

Place all parts in a pan containing clean oil. Discard all o-rings and gaskets.

#### CAUTION

Never clamp the pump in a vice without using the fixture.

(1) Mount the pump in holding fixture and secure.

(2) Remove three screws (1) and remove cover containing solenoid.

(3) Rotate shut-off lever (21) to full shutoff position; place a screwdriver between housing and linkage hook (50) and pry off shutoff cam (25). Discard shutoff cam.

(4) Partially withdraw throttle shaft assembly (26) and lift out throttle shaft lever (45), spacers and damper barrel assembly (88).

(5) Remove throttle shaft assembly and shutoff shaft assembly (24).

(6) Loosen end plate sleeve.

(7) Remove screws (63), lockwashers (64), flat washers (65), and transfer pump and plate (66).

(8) Remove thrust plate (67).

(9) Remove the pressure regulating sleeve (55) from end plate (66). Slid off filter element (57). Remove adjusting plug (54). Shake out the regulating spring (60) and piston (61). Reverse the assembly and remove the regulating piston seal (62).

(10) To disassemble transfer pump, lift out transfer pump seal (68), liner (72), blades (71), and springs (70).

(11) Remove the speed droop adjusting cap assembly (73) by pulling it from control rod guide (75).

1. Screw, cover
2. Washer, lock
3. Washer, flat
4. Cover, mechanical governor
5. Connector, return line
6. Gasket
7. Nut
8. Nut, lock
9. Washer, contact
10. Washer, insulating
11. Tube, insulating
12. Tube, insulating
13. Spring, shutdown arm
14. Sleeve, spring
15. Arm assembly, shutdown
16. Frame assembly, solenoid

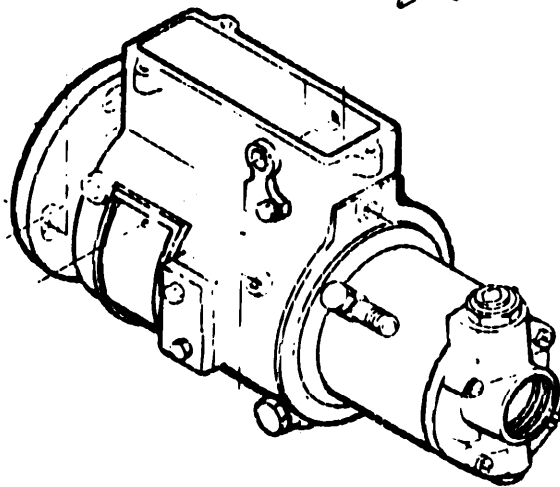
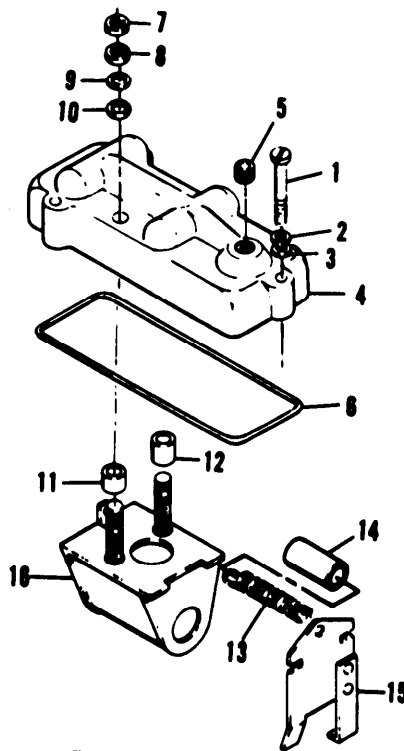

ME 5-6115-465-34/3-19 (1)

Figure 3-19. Fuel Injection Pump, Exploded View (Sheet 1 of 7)

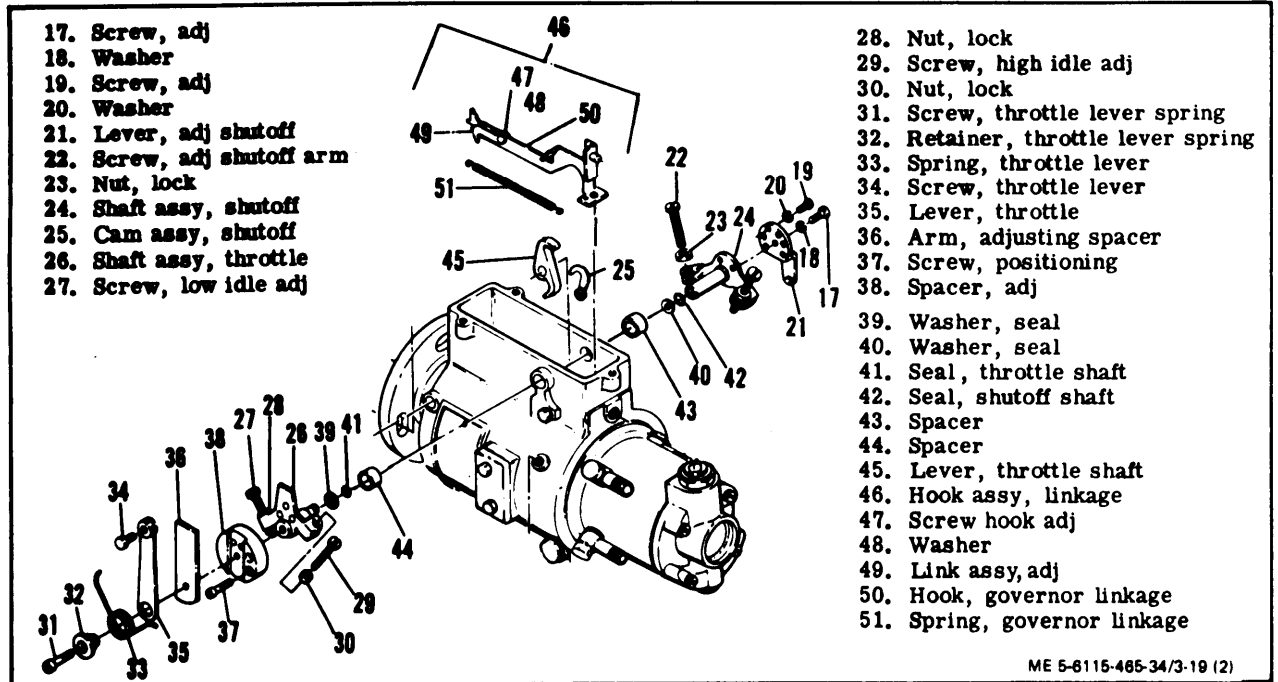

Figure 3-19. Fuel Injection Pump, Exploded View (Sheet 2 of 7)

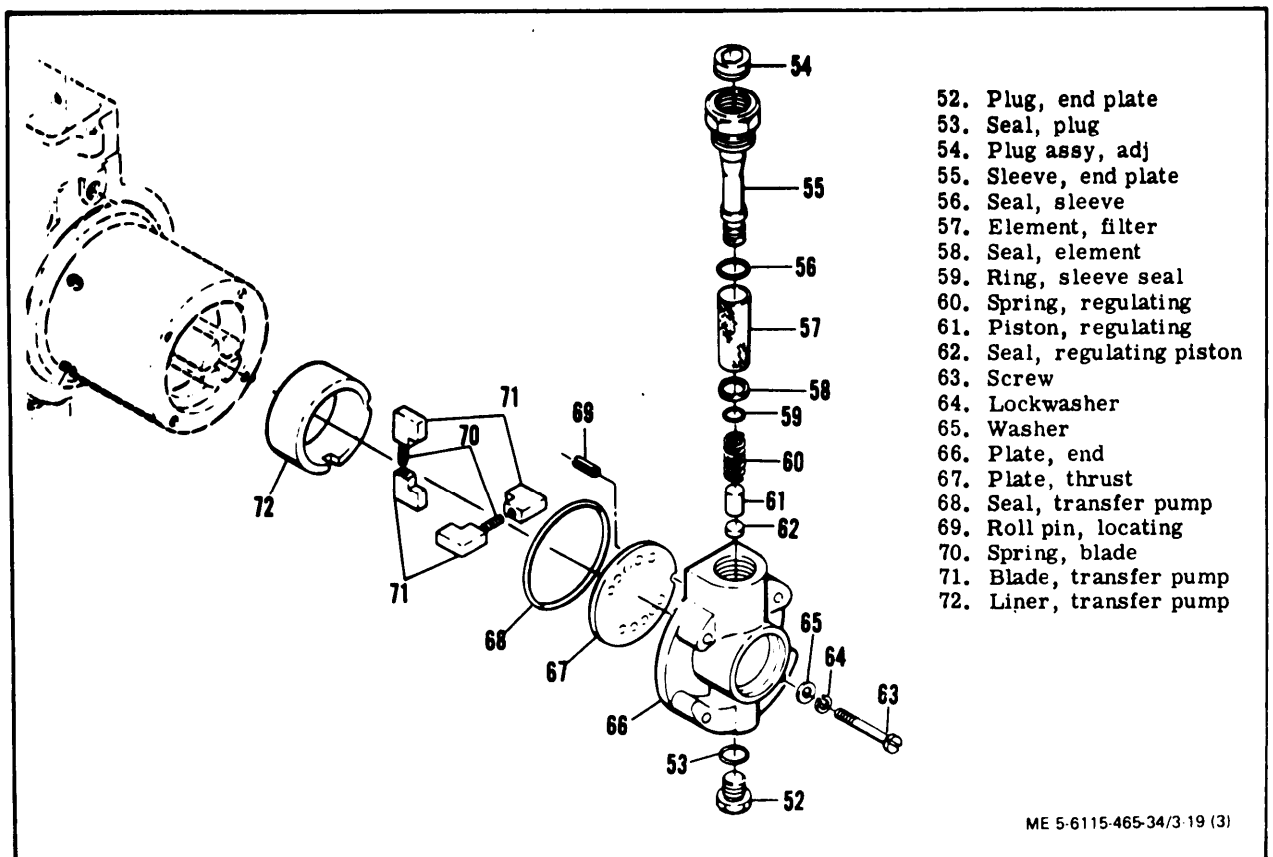

Figure 3-19. Fuel Injection Pump, Exploded View (Sheet 3 of 7)

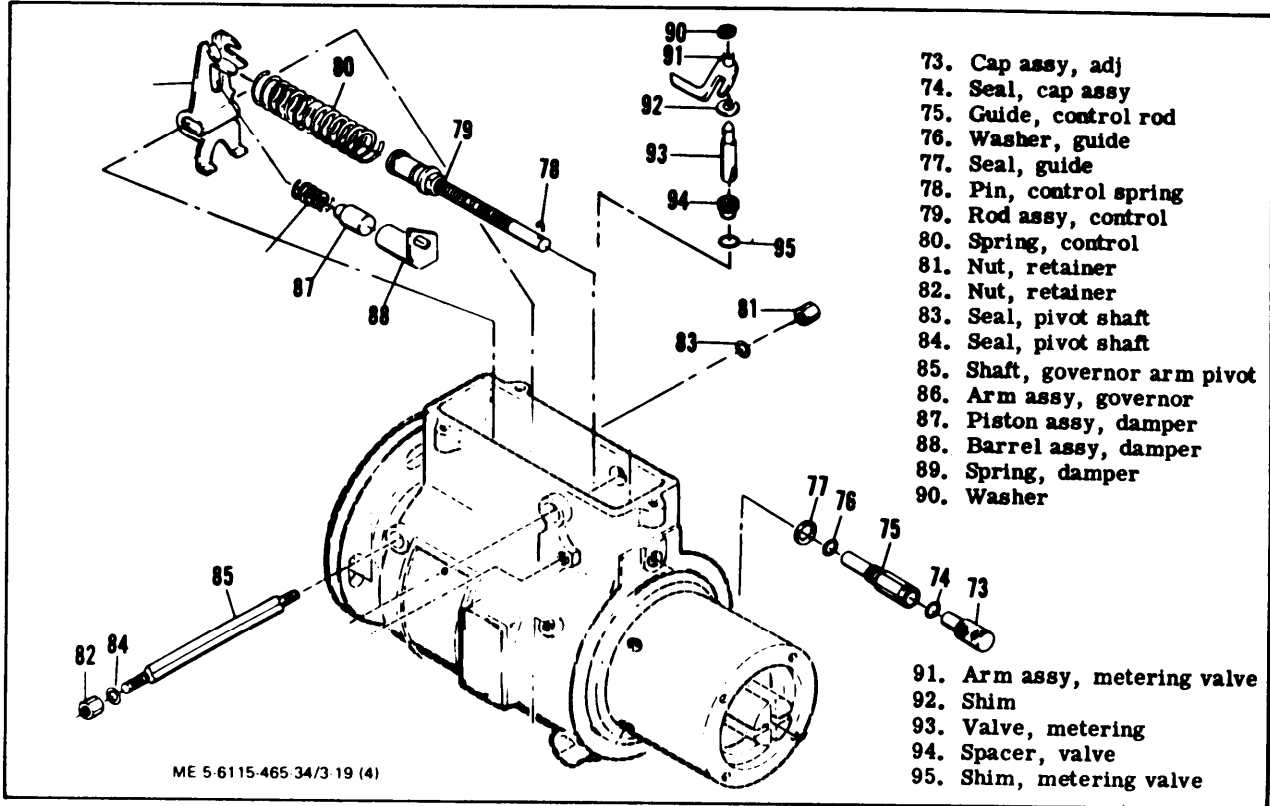

Figure 3-19. Fuel Injection Pump, Exploded View (Sheet 4 of 7)

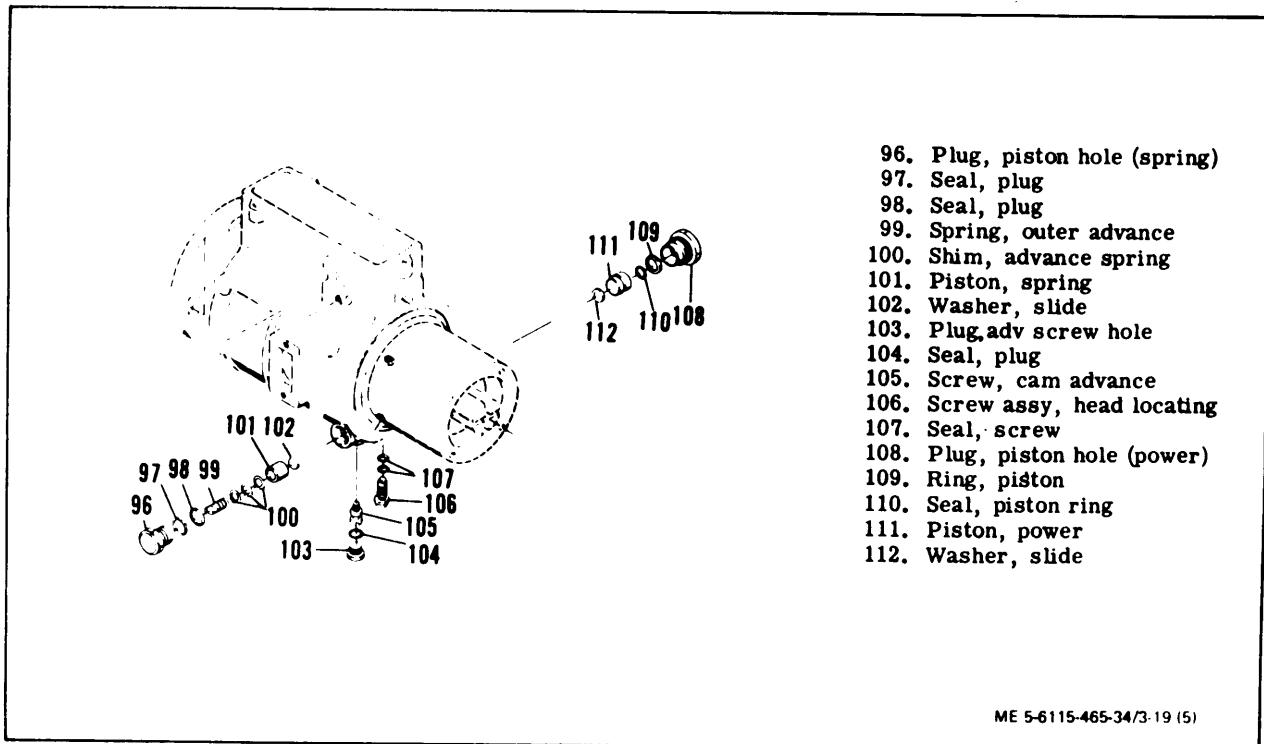

Figure 3-19. Fuel Injection Pump, Exploded View (Sheet 5 of 7)

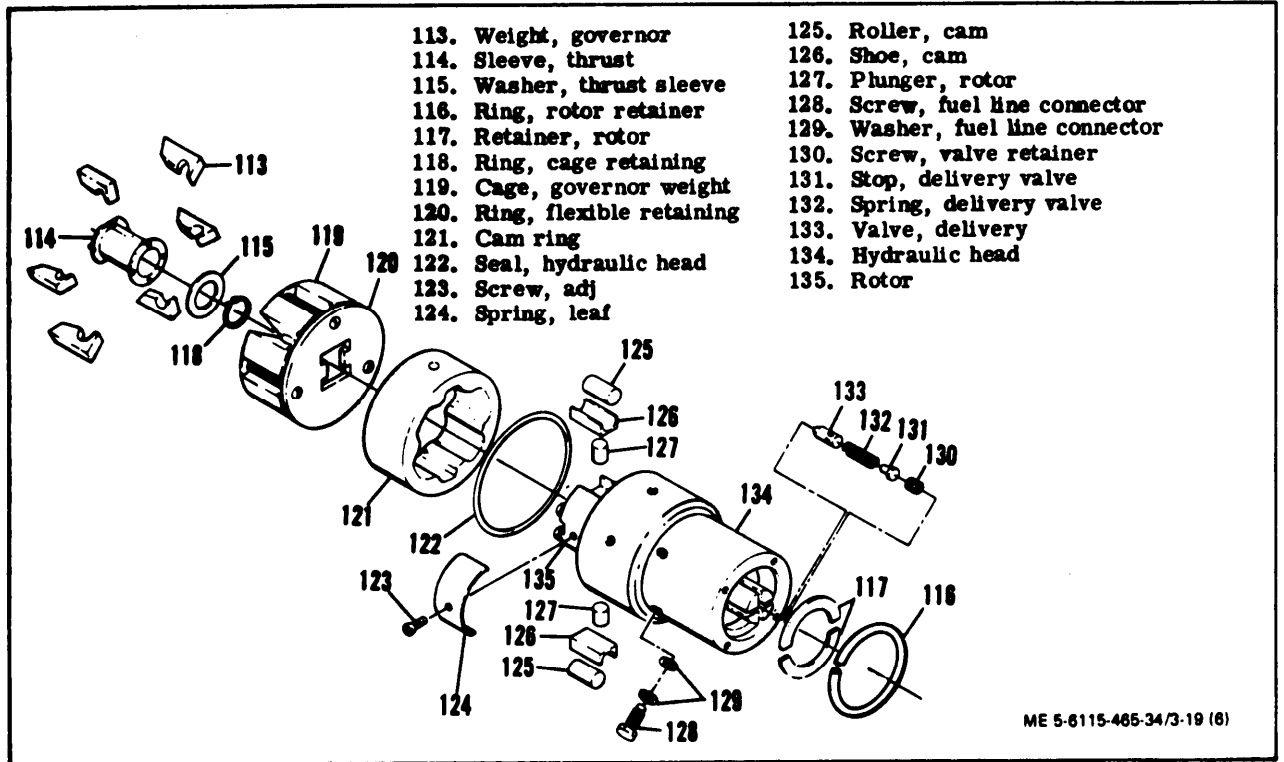

Figure 3-19. Fuel Injection Pump, Exploded View (Sheet 6 of 7)

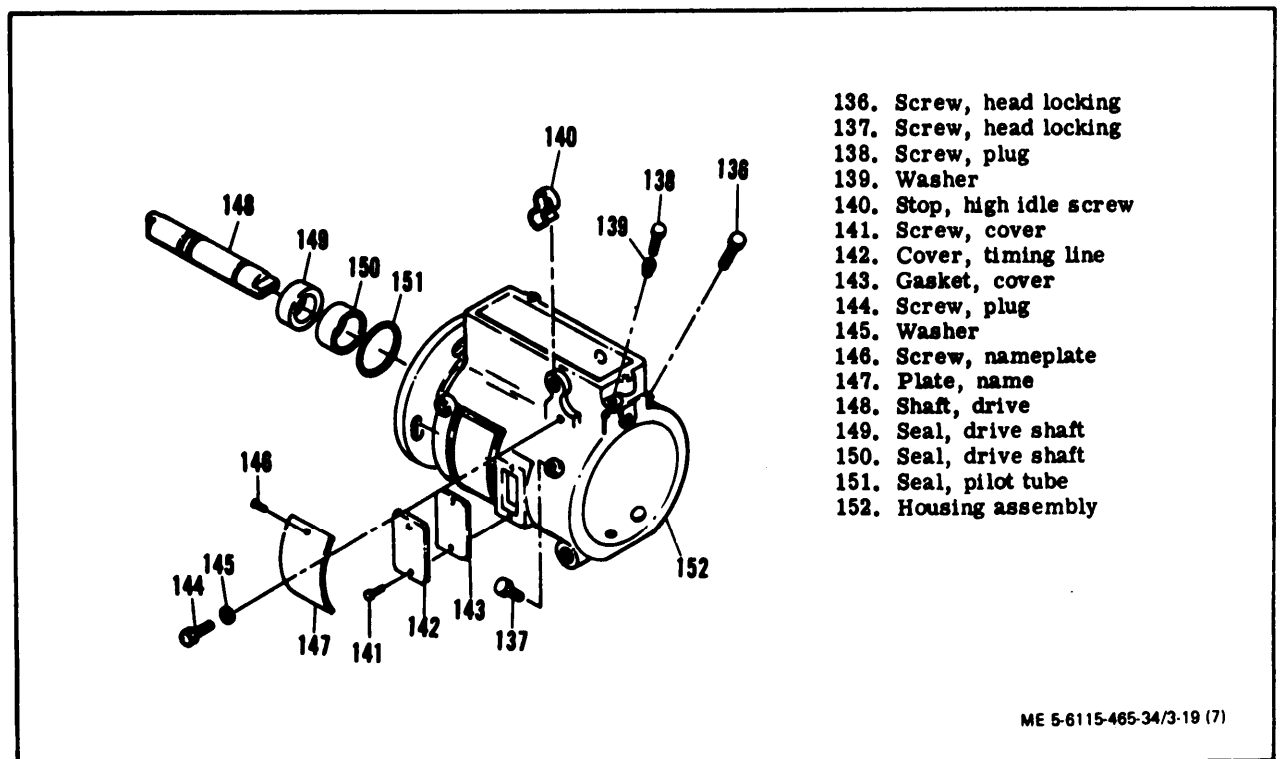

Figure 3-19. Fuel Injection Pump, Exploded View (Sheet 7 of 7)

(12) Remove and discard control spring pin (78).

(13) Discard seals (74 and 77), control rod guide (75) and washer (76).

**CAUTION**

Use care not to bend control rod.

(14) Disengage governor spring (80) from the governor arm (86), then remove the governor spring and control rod assembly (79).

(15) Remove the metering valve (93) and arm assembly (91) from the hydraulic head.

(16) Remove head locking screws (136 and 137) from the pump housing (152).

(17) Invert pump and holding fixture as a unit and remove head locating screw (106), advance screw hole plug (103). Remove the advance spring and power piston plugs (96 and 108). Using the cam advance screw removal bushing, part number 15500, and the Bristol socket cam advance screw wrench, part number 15499, remove the cam advance screw (105).

**NOTE**

The sides of the housing just above the advance bears a "C" denoting clockwise pump rotation as viewed from the drive end. The power side of the piston is located on the "C" side of a clockwise rotation pump.

(18) Invert the holding fixture in the vise. Grasp the hydraulic head firmly in both hands and withdraw with a slight rotary motion. Use caution not to drop the governor weights (113).

(19) To disassemble the governor, invert the hydraulic head and rotor assembly and let the governor weights (113), governor thrust sleeve (114) and governor thrust sleeve washer (115) fall into your hand.

(20) Place the hydraulic head assembly on pump holding fixture so that the governor weight retainer (119) engages the bar on the fixture.

(21) Remove pivot shaft nut (81) and seal (83) from one side of pivot shaft (85). Slide pivot shaft out one side of the housing and lift out governor arm (86).

(22) Using a 5/32 inch Allen wrench, loosen the delivery valve retainer screw (130) and remove it.

(23) Lift head and rotor assembly and shake delivery valve stop (131), spring (132), and delivery valve (133) into the hand. If delivery valve sticks, remove using extractor. Discard delivery stop.

(24) Using a small-bladed screwdriver or a dull scribe, disengage and remove the rotor retainer snap ring (116). This releases the rotor retainers which should now be moved outward as far as possible to clear the rotor.

**CAUTION**

When the rotor retainers are removed, the rotor is no longer retained in the head.

(25) Gently lift the hydraulic head off the distributor rotor (135). Invert the hydraulic head and shake out the rotor retainers (117).

(26) Lift off the cam ring (121). Check and record the roller-to-roller dimension as instructed in the assembly procedures. This dimension should be  $1.9640 \pm 0.0005$  inches. Remove rollers (125), shoes (126), plungers (127), and leaf springs (124). Discard spring screws (123).

**CAUTION**

Do not handle rotor shank.

(27) Remove governor weight retainer snap ring (118) with snap ring pliers.

(28) The flexible retaining ring (120) should be replaced whenever the pump is disassembled. Insert the snap ring plier, in the closed position, under the edge of the retaining ring between only two of the rivets. Spread the pliers while applying pressure in an upward direction. A slight twisting motion will snap the ring off the rivet. Repeat the process until the retaining ring is free from all rivets. Discard the retaining ring.

**d. Cleaning, Inspection, and Repair.**

(1) Inspect all springs, bores, grooves, and seal seats for wear, breakage, or damage. Repair or replace as necessary.

(2) Carefully inspect transfer pump blades for chipping on any edges, pitting, imbedded foreign particles, or wear on the rounded ends. Visually check flat surfaces for scores. Determine blade wear by measuring the length (0.538 inches minimum).

**CAUTION**

Do not handle the rotor shank. Do not force the plungers into their bore.



(3) While holding the rotor under fuel, insert the plungers into their bore. With thumb and fore-finger over the guide slots, tilt the rotor from side to side several times to insure complete freedom of movement of the plungers. Interchanging or reversing their individual positions may be necessary, as these are mated parts. Replace defective parts. If plungers are not visibly damaged, clean them with a soft brush and a lacquer removing solvent such as lacquer thinner or acetone.

(4) Examine the radii of the rotor which is contacted by the leaf springs, and the weight retainer for wear. Check all slots, charging and discharge parts of the hydraulic head for chipping or erosion of edges. Check the rotor shank for scratches.

#### NOTE

The rotor and hydraulic head are matched parts and shall be replaced as a unit.

(5) Check the vent wire in the hydraulic head air bleed passage for freedom of movement. If the wire is free, flush the head and blow out all passages with clean, dry compressed air. If the wire is stuck, replace it after thoroughly cleaning the passages.

(6) Check each cam roller for freedom of rotation in its shoe. Check each shoe for chipping or wear on the surface contacted by the leaf spring.

(7) Check the leaf springs for cracks, nicks, chipping, or distortion. Check for damage and wear along rotor radii contact points and steps which retain roller shoes.

(8) Examine the retainer sockets of governor weight retainer and the pivot point of each governor weight for evidence of wear or damage. Replace the flexible snap ring (120) of the weight retainer.

(9) Inspect the pivot points of the governor arm (86) pivot shaft for wear. Check the governor arm tabs at the point which contacts the thrust sleeve. If either tab is worn flat, replace the governor arm.

(10) Examine the junction points of the metering valve pin hole in the linkage hook, throttle lever, shutoff cam, and shutoff lever for looseness and burrs.

(11) Check the metering valve body for wear. Ascertain that the metering valve arm is well seated and there is no radial movement of the arm on the valve. Check the metering valve arm pin for wear or looseness.

(12) Carefully inspect the bore and edges of all flat surfaces of the cam. If evidence of spalling or flaking out exists, replace the cam.

#### NOTE

Since only the working portions of the cam lobes on the bore are ground, the tool marks between lobes should not be considered as damage. The cam finish is mottled from heat treatment rather than operation.

(13) Visually inspect the drive shaft for undue wear or cracking. Check the diameter where the thrust sleeve slides for scores. Check for smoothness of seal grooves. They must be absolutely smooth.

(14) Check the regulating piston for freedom of movement in the end plate sleeve. Check all threads for damage. The filter element should bear no evidence of damage. Clean all dirt or rust from the element.

#### CAUTION

Check for tightness of the orifice plate. Replace adjusting plug if plate is loose.

(15) Check that the damper piston (87) moves freely in the damper barrel (88). Inspect for chipping of piston or scratches to the piston and damper barrel bore. The bleed orifice should allow free flow when the piston is inserted. Replace components as necessary.

e. Assembly.

#### NOTE

All parts should be flushed in clean oil as they are assembled. Replace all seals and gaskets.

#### CAUTION

Install piston seal dry. Do not use grease.

(1) Insert regulating piston seal (62) into the lower end of the regulating sleeve assembly (55) far enough to expose retaining ring groove. Install retaining ring (59).

(2) Install regulating piston (61) and spring (60) into the sleeve making sure that the piston slides to the bottom of the sleeve bore without binding.

(3) Install end plate adjusting plug (54) into the sleeve until all threads are just below port "A".

#### CAUTION

Do not exceed this position as excessive transfer pump pressure could occur.

(4) Insert regulating sleeve assembly into the bore in end plate (66).

(5) Fit the transfer pump thrust plate (67) on the end plate (66).

**NOTE**

The thrust plate may be reversed if one side appears worn or scratched. A small amount of grease may be used to hold the thrust plate in place.

**CAUTION**

Do not use force when inserting rotor. Binding may be caused by the presence of foreign particles. If rotor binds, withdraw it, rinse the rotor and hydraulic head in clean fuel and attempt to assemble again.

(6) Immerse rotor (135) and hydraulic head (134) in clean oil and assemble with it slight rotary motion.

(7) Install delivery valve (133) making sure that it moves freely in its bore. Install spring (132) and stop (131). Install screw (130) and torque to 85-90 inch-pounds.

**NOTE**

The screw (130) has one end which is relieved to clear the delivery stop. Be sure that this end faces the stop.

(8) Place the hydraulic head and rotor in the holding fixture. Insert plungers (127) into the rotor bores. Install shoes (126), rollers (125) and leaf springs (124).

(9) Adjust roller-to-roller dimension as follows: (See figure 3-20)

(a) Apply clean, dry air at 30 to 100 pounds per square inch by means of a suitable fitting to any one of the head outlets.

(b) Rotate the rotor until the rollers are pushed to their extreme outward position.

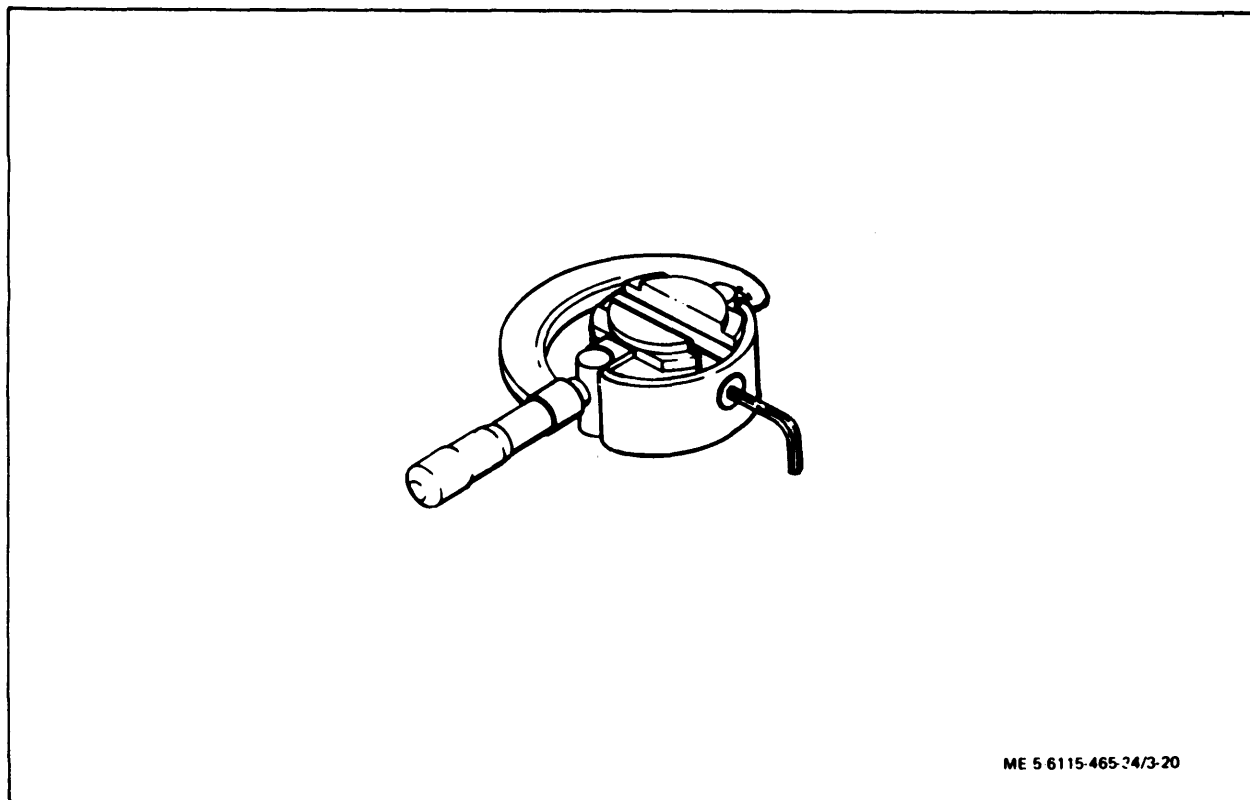

Figure 3-20. Adjusting Fuel Injection Pump Roller-to-Roller Dimension

(c) Using a 1 inch to 2 inch micrometer, measure the roller-to-roller dimension. If roller-to-roller dimension is not  $1.964 \pm 0.0005$  inch, adjust screw (123, figure 3-19).

#### NOTE

Turning screw clockwise increases the roller-to-roller dimension. Turning screw counterclockwise reduces roller-to-roller dimension.

(10) Place the cam ring (121, figure 3-19) atop the hydraulic head, making sure that the rotation arrow points clockwise.

(11) Place the governor weight retainer (119) over the drive of the distributor rotor. Make sure that the assembly marks on the weight retainer and the rotor align with each other. Install retaining ring (118).

#### CAUTION

Use care when inverting the hydraulic head, as the rotor not retained and could easily fall out.

(12) Invert the hydraulic head in the holding fixture so that the governor weight retainer engages the bar.

(13) Lift the hydraulic head slightly so that its inside face aligns with the rotor end and install retainers (117). Install retaining (116).

(14) Insert the transfer pump liner (72) into the hydraulic head so that the large slot is in line with the head locating screw hole and the letter 'C', which signifies pump rotation, is up. This will correctly position the liner locating sick to accept the end plate locating pin.

(15) Carefully insert the transfer pump blades (71) and springs (70) taking care to to cock them. Rotate the liner several times to check for freedom of movement. Return the liner to the correct position.

(16) Install transfer pump seal (68).

(17) Slip the head and rotor assembly, drive end up, into the holding fixture. Place the six governor weights (113) in their sockets with the slots facing the bore of the assembly. Place the thrust sleeve washer (115) against the thrust sleeve (114) so that the camfered edge faces the sleeve. Insert the forefinger into the bore of the sleeve and washer, holding them together, and insert them into the slots of the governor weights by tilting the weights slightly back. The two slots on the thrust sleeve flange should face up. Sight across the tops of the assembled weights to ascertain correct positioning. One weight higher than others indicates incorrect assembly of the thrust washer.

(18) Place the governor arm (86) in position with the fork for the governor linkage hook facing the end plate. Insert pivot shaft (85) with the knife edge facing the end plate and assemble the two seals (82 and 84) and nuts (81 and 82). Tighten the nuts simultaneously to a torque of 20 to 25 inch-Pounds.

(19) Install a new seal (122) on the hydraulic head. Rotate the cam ring so that the unthreaded hole is in line with the metering valve bore to insure proper positioning of the cam. Apply a light film of clean grease around the inside edge of the housing (152).

#### CAUTION

Do not use force. If the hydraulic head should cock during insertion, withdraw and start over.

(20) Grasp the hydraulic head firmly in both hands and insert it into the housing with a slight rotary motion.

#### NOTE

Make sure that the assembly is wrung into position past the hydraulic head seal (122). Failure to do this may result in leakage.

(21) Rotate the hydraulic head until the head locking screw holes are aligned. Install head locking screws (136 and 137) finger tight.

(22) Invert the pump and holding fixture in the vise so that the bottom faces up.

(23) Install seals (107) and head locating screw (106).

(24) Install seals on piston plugs (96 and 108).

(25) Install piston ring seal (110) and piston ring (109).

(26) Install cam advance screw (105) using tool number 15500 and 15499 and torque to 400 inch-pounds. Install seal (104) and plug (103).

(27) Using the piston ring installing tool (part number 16199), slide power piston plug (108) over piston (111).

(28) Install spring (99), shim (100), piston (101), and slide washer (102) into plug (96). Install seal (98) onto plug (96).

(29) Install plugs (96 and 108) with their assembled parts into the housing and torque to 215 to 265 inch-pads.

NOTE

Make sure that the power piston plug is on the right side of the pump as viewed from the transfer pump end.

(30) Torque plug (103) to 40 to 50 inch-pounds.

(31) Torque head locating screw (106) to 300 inch-pounds.

(32) Torque head locking screws (136 and 137) to 175 inch-pounds.

(33) Invert the pump and holding fixture in the vise.

CAUTION

Never sand or polish off the special treatment on the valve.

(34) Install the metering valve (93) and shims (95) into its bore. Depress and rotate the valve several times to insure freedom of movement. If valve sticks, lap it carefully in clean oil.

(35) Metering Valve Setup:

(a) Install No. 11610 shim and No. 16575 spacer on metering valve.

(b) Thread control rod guide No. 20223 into pump (finger tight).

(c) Check clearance between valve and control rod guide. Add shim No. 16576 through 16583 (as required) to control clearance between 0.002 in. and 0.005 in. maximum.

(36) Pull back on the governor linkage hook (50) stretching the spring just enough to connect the hook correctly to the fork on the governor arm (86). Position the other end over the pin on the metering valve arm (91). Check all governor parts again for freedom of movement.

(37) With the end plate (66) removed, install the speed droop control rod through threaded hole from inside of pump housing.

(38) Slide speed droop guide (75) with seal (77), assembled over end of rod (79) and thread into the housing. Tighten securely.

(39) Insert control spring pin (78) into hole at end of rod (79).

(40) Assemble seal (74) to groove at end of guide (75) and install speed droop cap assembly (73) over seal.

(41) Install end plate (66), making sure that guide pin (69) enters the slot in the transfer pump

liner (72). Install flat washers (65), lockwashers (64), and screws (63) and torque to 25 to 30 inch-pounds.

(42) Thread five full turns of spring (80) onto speed droop control rod (79). Slip the free end of the spring over the formed ends of the governor arm (86) with the bent-in ends of the spring between the two tabs.

NOTE

The apparent looseness in the governor parts is normal. Lost motion is immediately taken up as soon as the pump actuates.

(43) Assemble the throttle shaft assembly (26) with lever (35) installed partially into position through the housing. Slide the spacer bushing (44) and the throttle shaft lever (45) over the throttle shaft so that the projection on the throttle shaft lever bore engages the keyway on the shaft. Position the throttle lever so that its forward tab straddles the linkage hook tab. Apply a light coat of grease to the throttle and shut off seals (41 and 42). Assemble the shutoff shaft assembly (24) from the opposite side of the housing with a slight rotary motion. Locate and secure shutoff cam (25),

(44) Rotate the shaft until a click is heard. This is the governor arm (86) engaging the governor thrust sleeve.

(45) With the throttle shaft in the wide open position, check the clearance between the rear of the throttle shaft (B) and the vertical tab (A) on the linkage hook. This clearance should be 0.210 to 0.225 inch. (See figure 3-21.)

NOTE

Adjustment of this clearance is made by changing the effective length of the linkage hook.

(46) With adjusting screw (C) tight, apply pressure to tab (A). At the same time, rotate one or two complete revolutions to assure that the linkage is in the full forward position. Loosen adjusting screw (C) and slide the linkage to the full forward position. Insert linkage gauge No. 18914 between the vertical tab (A) and the shutoff shaft (B). Slide the linkage hook until the face of the tab is flush against the gauge. Tighten adjusting screw (C) and remove gauge. Check the adjustment and reset if necessary.

(47) Check all governor parts for freedom of movement.

(48) Assemble frame assembly (16, figure 3-19), spring sleeve (14), spring (13) and arm assembly (15).

(49) Adjust armature as illustrated in figure 3-22.

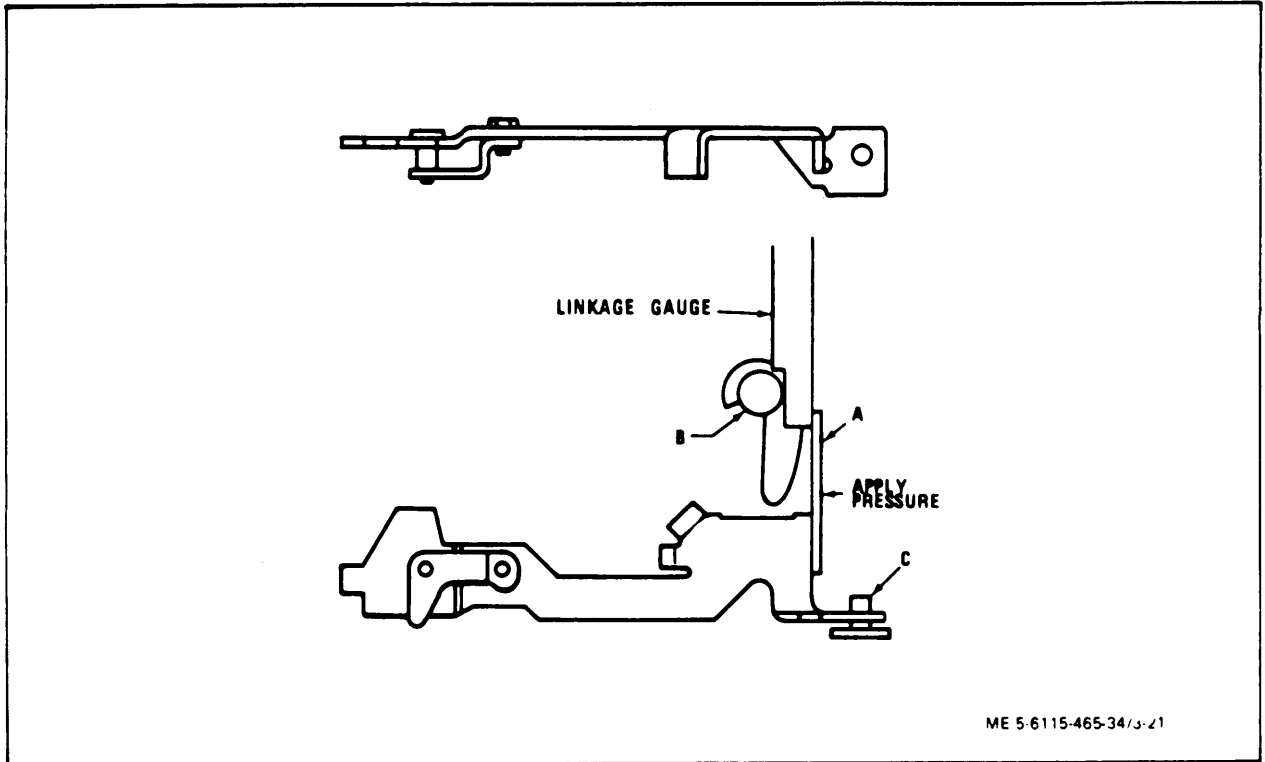

Figure 3-21. Throttle Linkage Adjustment

(50) Install new insulating tubes (11 and 12, figure 3-19) and secure frame to cover (4) with insulating washers (10), contact washers (9), and lock-nuts (8).

(51) Install new gasket (6) to cover (4) and secure cover to pump with flat washers (3), lock-washers (2) and screws (1).

f. Fuel Injection Pump Bench Test.

(1) General. The bench test procedure is based on the following conditions:

(a) Injection lines are 3/32 inch ID by 30 inches long.

(b) Fuel readings are based on fuel with a viscosity of 34-36 SSU at 100 F.

(c) Fuel temperature at 110 to 115°F.

(d) Nozzles, part number 12SD12, adjusted to opening pressure of 2500 psi (170 ATS).

(2) Test procedure.

(a) Mount pump securely in diesel injector test stand using a suitable adapter. The drive adapter, usually with a ball bearing, supports the shaft. This pump must be tested with an intermediate support

bearing. Install high pressure injection lines using new gaskets. Leave fuel line connector screws at pump and injection line nuts at the nozzles loose. Install fuel inlet and return lines. Install transfer pump pressure gauge with a shutoff valve as close to the transfer pump as possible.

NOTE

Transfer pump pressure gauge must be isolated by shutoff valve at the fuel injection pump when checking fuel delivery and advance movement.

(b) Set counter and tachometer switches to clockwise position.

NOTE

Pump runs at half the engine speed.

(c) Start the test stand at lowest speed and check for clockwise rotation. Move throttle to full-load position. When transfer pump picks up suction, allow fuel to bleed for several seconds from loosened connector screws and injection line nuts, then tighten securely.

(d) Operate pump at 500 rpm for 10 minutes. Dry off completely with compressed air.

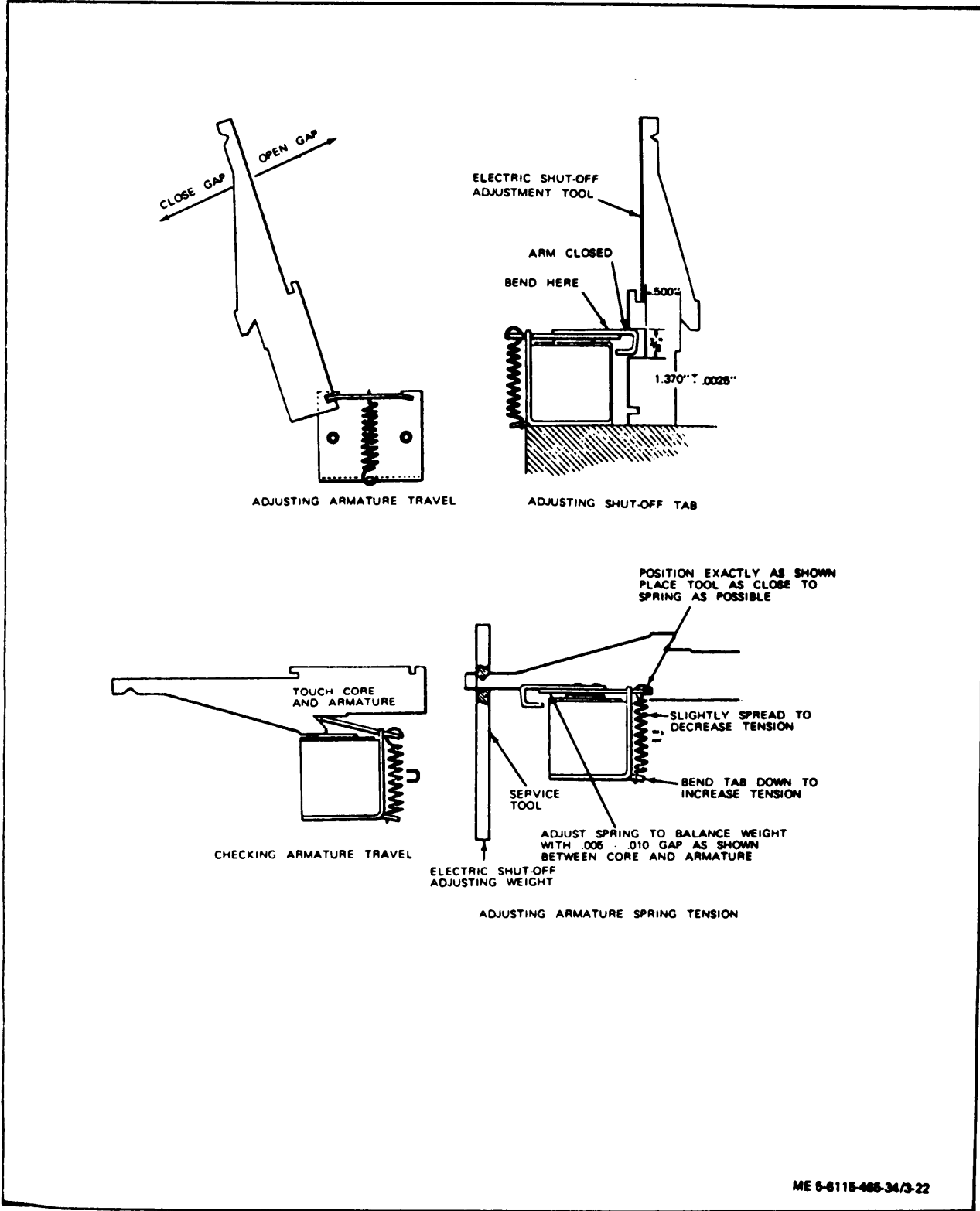

Figure 3-22. Solenoid Armature Adjustments

Table 3-1. FUEL DELIVERY

PUMP RPM	DELIVERY (mm <sup>3</sup> /stroke)	PRESSURE PSIG	MAX VAR BETWEEN CYLINDERS
900	56-59	70-75	3
750	55-58		4
927 (high idle)	15-20		

Observe for leaks and correct as necessary. Back out high idle stop screw.

**NOTE**

The inlet to the fuel transfer pump should never be pressurized during beach testing.

(e) Close valve in reapply line - transfer pump must pull at least 18 inches of mercury at 200 rpm. If it does not, check for air leaks on suction side or malfunction of end plate and transfer pump parts.

(f) Pill graduates to bleed air from teat stand and to wet glass.

(g) Observe return oil. Return should be at rated 100-450 cc/minute at 35 psi transfer pump pressure.

**CAUTION**

Under no circumstances should 130 psi be exceeded, as the pump will be damaged.

(h) Operate pump, with wide open throttle and observe transfer pump pressure. Pressure should be 70 to 75 psig. If it is not, use a hex key wrench and adjust pressure regulating spring by 1/4 turns, clockwise to raise pressure - counterclockwise to lower pressure.

(i) Perform automatic advance check as follows:

**NOTE**

Each mark on the timing window is 2 pump degrees.

1. Check at 250 to 400 rpm for one degree cam movement.

2. Drain burettes for 30 seconds minimum.

3. Check at 450 to 550 rpm for 3-1/2 degree cam movement.

(j) Perform speed droop adjustment as follows: (See table 3-1.)

1. At 900 rpm and wide open throttle adjust high idle screw temporarily for 15-20 mm<sup>3</sup> delivery per stroke.

2. Raise pump speed to 927 rpm and turn the droop adjustment cap assembly clockwise as viewed from the trader pump end of injection pump to obtain a delivery of 15-20 mm<sup>3</sup> per stroke.

3. Lower pump speed to 900 rpm and check fill load delivery rate. If 56-59 mm<sup>3</sup> delivery rate is not realized, repeat steps 1. and 2. above until 56-59 mm<sup>3</sup> is obtained.

4. When step 3. requirements are met, lock the high idle adjusting screw.

5. If fuel pump is to be used for 400 Hz application, reset high idle speed screw to 1125 rpm.

(k) Check delivery at 750 rpm. If delivery is not 55-58 mm per stroke, repeat step (j) above until it is.

(l) Raise pump speed to 950 rpm and check for a delivery rate of 5 mm<sup>3</sup> maximum.

(m) Lower pump speed to 900 rpm and de-energize the solenoid, Check for 5 mm<sup>3</sup> maximum delivery rate.

(n) At the same speed, energize the solenoid and check the manual shutoff for the same delivery rate of 5 mm<sup>3</sup> maximum.

(o) At a pump speed of 200 rpm repeat steps (n) and (o). Delivery shall be 2 mm<sup>3</sup> maximum.

(p) Check minimum cranking speed delivery as follows:

1. Check transfer pump for 8 psig minimum and close the shutoff valve to gauge.

2. Check for 35 mm<sup>3</sup> per stroke, minimum, at 75 rpm.

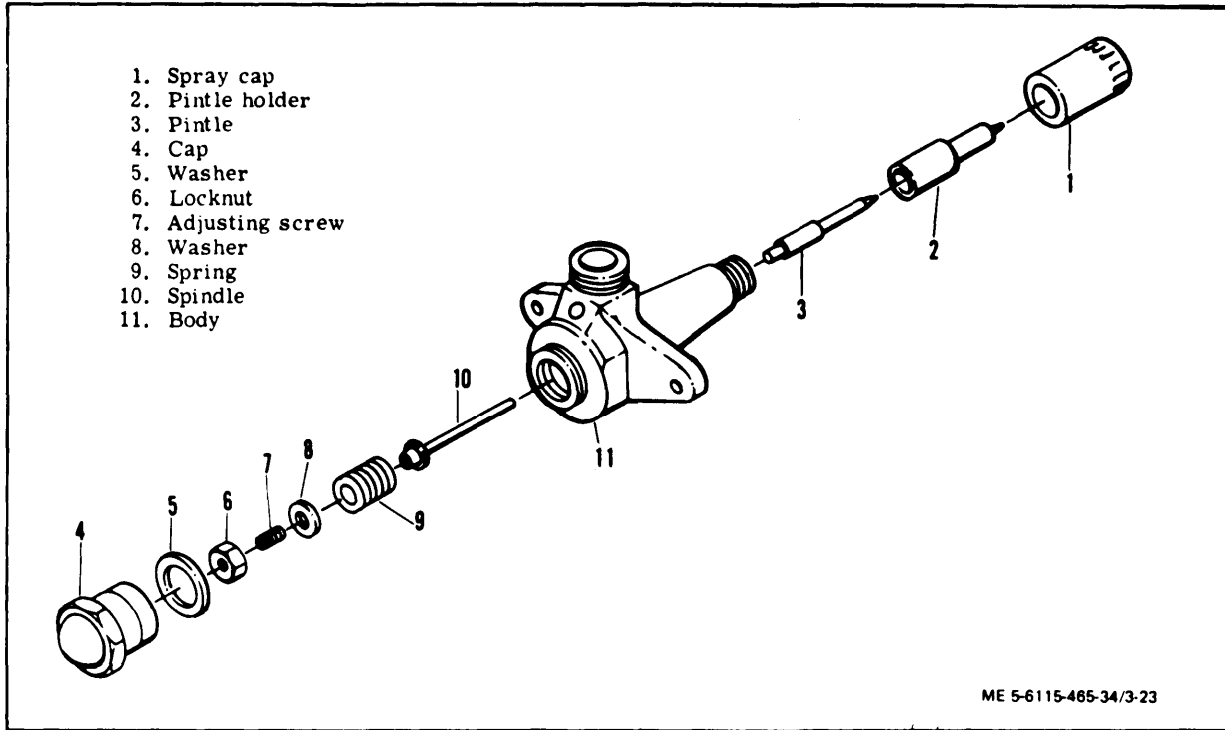

Figure 3-23. Fuel Injection Nozzle Holder, Exploded View

(q) Remove pump from test stand.

g. Installation.

(1) Remove fuel injector nozzle from No. 1 cylinder.

(2) Turn the engine over until the 20 degree before top dead center (BTDC) mark on the flywheel is lined up with the timing mark on the flywheel housing, and No. 1 cylinder is on compression stroke.

(3) Remove the timing hole cover on the injection pump and rotate the pump shaft until the timing marks line up.

NOTE

The pump shaft should never be turned backwards to align internal timing marks.

(4) Install pump on engine and install attaching hardware.

(5) Recheck flywheel timing marks, then rotate the fuel pump body until the pump timing marks are exactly in line. Tighten pump attaching nuts to 35 to 40 ft-lb.

NOTE

After fuel injection pump is installed, rotate engine 180 degrees backwards. Then rotate engine in correct rotation until 20° BTDC timing marks on the flywheel appears in flywheel timing hole and recheck pump timing marks.

(6) Install pump timing hole cover.

(7) Install fuel injection lines.

NOTE

New injection pumps received from supply have a high idle adjustment of 1860 rpm for 60 Hz applications. Installation on 400 Hz generator sets requires resetting the high idle adjustment screw, (29, figure 3-19) to 2250 rpm. Adjustment is accomplished using an engine speed tachometer with actuator linkage (6, figure 3-18) disconnected, the shutoff lever, (21, figure 3-19) in the on-fuel condition, then manually operating the throttle lever (35, figure 3-19) against high idle stop.

NOTE

When replacing the fuel lines, always use new gaskets.

(8) Connect throttle linkage and stop control.

(9) Connect fuel supply and return lines.

(10) Replace No. 1 fuel injection nozzle in No. 1 cylinder.

(11) Bleed the air from the fuel system.

3-21. FUEL INJECTION NOZZLE HOLDERS AND LINES.

a. Removal. Refer to the Operator and Organizational maintenance Manual for fuel injection nozzle holders and lines removal instructions.



b. Disassembly.

(1) Unscrew spray cap (1, figure 3-23) and remove pintle holder (2) and pintle (3).

(2) Remove cap (4) and washer (5).

(3) Remove lock nut (6), adjusting screw (7), and washer (8) to remove spring (9) and spindle (10) from body (11).

c. Cleaning and Inspection.

(1) Soak nozzle holder parts in a container of clean fuel and dry with a clean, lid-free cloth.

(2) Inspect pintle, pintle holder and spray cap for cracks, corrosion, erosion from fuel flow and other damage.

(3) Check body, spindle, and cap for cracks, corrosion, breaks, and other damage.

(4) Check spring for fretting, cracks, breaks, corrosion, and distortion.

(5) Check all threaded parts for cross, stripped, or otherwise damaged threads.

d. Repair. Repair nozzle holder by replacing defective parts.

e. Assembly.

(1) Install spindle (10, figure 3-23) and spring (9) into body (11).

(2) Install washer (8), adjusting screw (7) and locknut (6).

(3) Insert pintle (3) into pintle holder (2).

(4) Position pintle holder in body and secure with spray cap (1).

(5) Do not install washer (5) and cap (4) until after adjustment.

f. Testing and Adjustment.

(1) Install repaired nozzle holder on a standard static fuel nozzle testing fixture.

(2) Tighten adjusting screw all the way down.

(3) Apply fuel at 2500-2950 psig and slowly loosen adjusting screw until nozzle begins to open.

(4) Tighten locknut while holding adjusting screw with screwdriver.

(5) Lower fuel pressure. Nozzle holder assembly shall close.

(6) Slowly increase fuel pressure. Nozzle holder shall open at 2500-2950 psig.

(7) Observe fuel spray. Fuel spray shall be even and smooth. Spray cone shall be same thickness at a distance of 5 inches. There shall be no signs of leakage.

(8) Remove fuel pressure and remove nozzle holder from testing fixture.

(9) Install washer (5, figure 3-23) and cap (4).

g. Installation. Refer to the Operator and Organizational Maintenance Manual for fuel injection nozzle holder and lines installation procedures.

3-22. FUEL LINES.

Refer to the Operator and Organizational Maintenance Manual for fuel lines maintenance instructions.

3-23. START AID ASSEMBLY.

Refer to the Operator and Organizational Maintenance Manual for start aid assembly maintenance instructions.

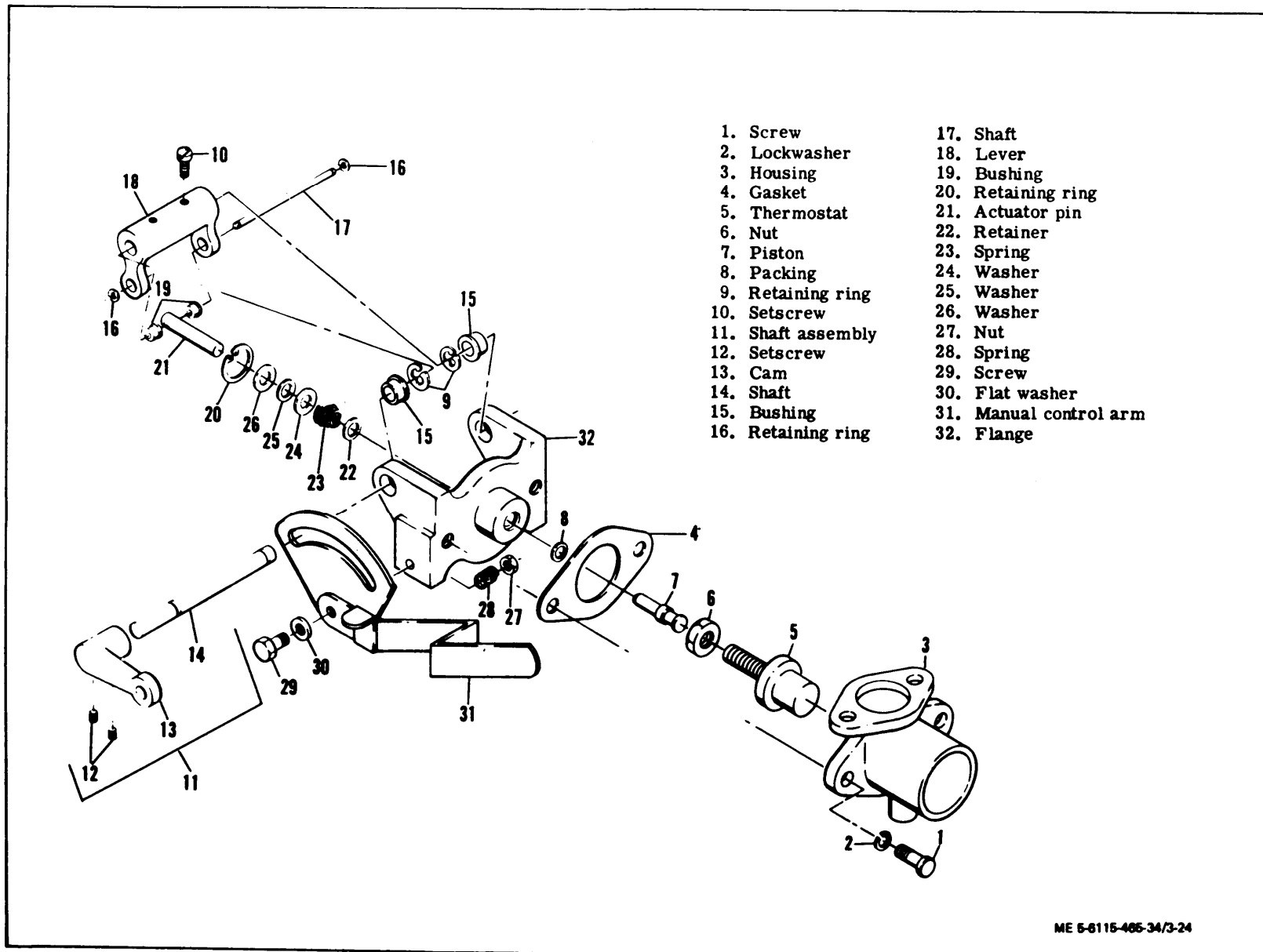

Figure 3-24. Shutter Control Assembly, Exploded View

### Section III. ENGINE COOLING SYSTEM

#### 3-24. GENERAL

The engine cooling system is a circulating pressure type system. It consists of a radiator, a belt driven cooling fan and centrifugal water pump, a coolant control thermostat, a thermostatically controlled shutter assembly, and a protective grille. The water pump receives coolant from the lower radiator hose and circulates it through the engine cylinder block and cylinder head. As it circulates through the engine, the coolant absorbs heat generated by engine operations. When the engine reaches normal operating temperature, the coolant control thermostat opens and the coolant returns to the radiator through the upper radiator hose. As the heated coolant circulates through the radiator, the cooling fan blows air through the radiator air passages which dissipates the heat. The shutter assembly blocks the flow of cooling air until the coolant in the radiator reaches normal engine operating temperature.

#### 3-25. GRILLE

Refer to the Operator and Organizational Maintenance Manual for grille maintenance instructions.

#### 3-26. SHUTTER CONTROL ASSEMBLY

a. Removal Refer to the Operator and Organizational Maintenance Manual for shutter control assembly removal instructions.

##### b. Disassembly.

(1) Remove screws (1, figure 3-24) and lockwashers (2) to remove housing (3), gasket (4), thermostat (5), nut (6) and piston (7). Discard gasket.

(2) Remove and discard packing (8).

(3) Remove retaining rings (9) and loosen setscrews (10) to remove shaft assembly (11). Do not disassemble setscrews (12), cam (19) and shaft (14) unless inspection reveals damage.

(4) Remove bushings (15).

(5) Remove retaining rings (16) to remove shaft (17), lever (18) and bushings (19).

(6) Remove retaining ring (20) to remove actuator pin (21) with assembled parts.

(7) Remove retainer, spring (29) and washers (24, 25, and 26) from actuator pin.

(8) Remove nut (27), spring (28), screw (29), and flat washer (30) to remove manual control arm (31) from flange (32).

##### c. Cleaning, Inspection, and Repair.

(1) Clean all parts with dry cleaning solvent (Federal Specification P-D-680) and dry thoroughly.

(2) Visually inspect housing and flange for cracks, breaks, corrosion, and other damage.

(3) Inspect shafts and pin for scores, deep water patterns and other damage.

(4) Inspect manual control arm for cracks, corrosion and excessive wear.

(5) Check springs for cracks, corrosion, breaks, chaffing and distortion.

(6) Inspect lever for cracks, corrosion, and excessive wear.

(7) Inspect bushings for scores and excessive wear.

(8) Refer to the Operator and Organizational Maintenance Manual and test thermostat.

(9) Replace any damaged or defective parts.

d. Assembly. Assemble shutter control assembly in reverse order of disassembly procedures.

e. Installation. Refer to the Operator and Organizational Maintenance Manual for shutter control installation procedures.

#### 3-27. RADIATOR

a. Removal. Refer to the Operator and Organizational Maintenance Manual for radiator removal procedures.

##### b. Cleaning, Inspection, and Repair.

#### **WARNING**

Always wear protective glasses when using compressed air to clean radiator air passages. Injury to the eyes may result from failure to observe this warning.

(1) Clean foreign particles from radiator core air passages with filtered compressed air.

(2) Clean exterior surface of radiator with dry cleaning solvent (Federal Specification P-D-680).

(3) Visually inspect radiator for excessive corrosion, cracked or broken brazing, and bent cooling fan.

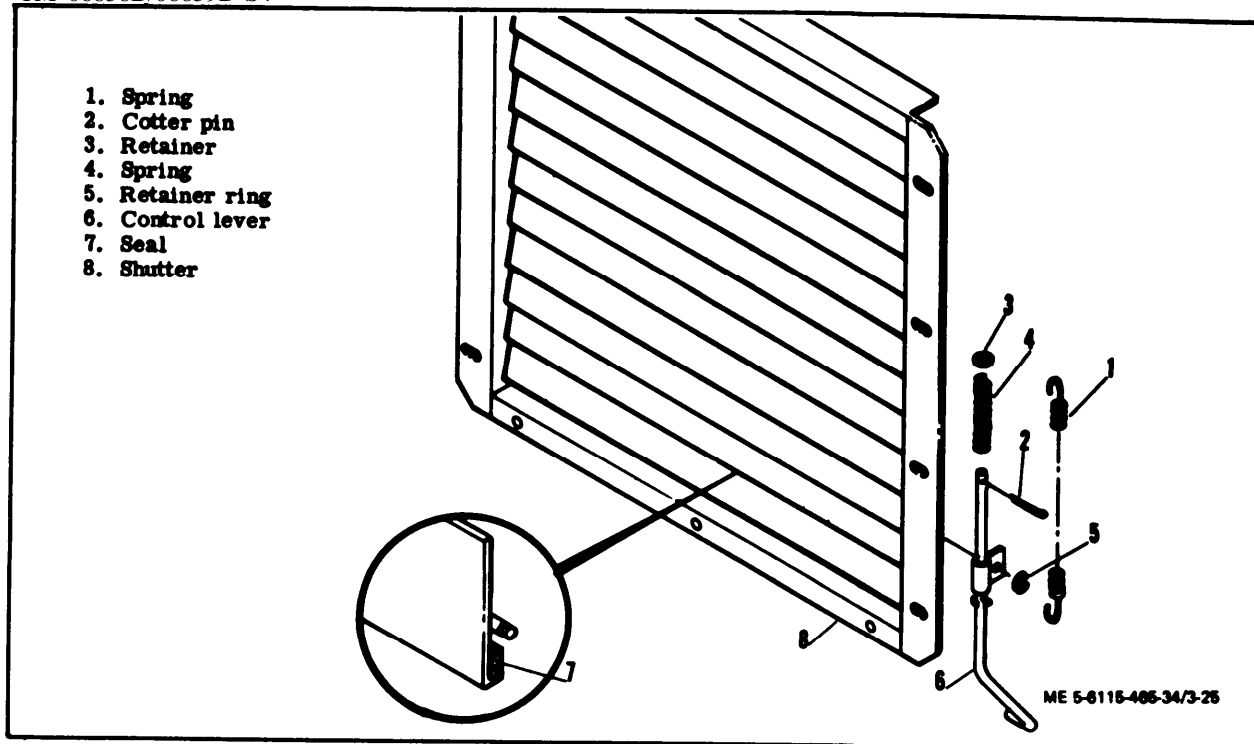

Figure 3-25. Shutter Assembly, Exploded View

(4) Check interior of radiator for rust and scale deposits.

(5) Test radiator for leaks as follows:

(a) Provide an air line fitting at one of the radiator openings. Seal all other openings.

(b) Attach an air line to the fitting and submerge the radiator in a container of water.

(c) Pressurize the radiator to 10 to 15 psig and check for air bubbles which will indicate leakage.

(6) Repair radiator as follows:

(a) Straighten bent cooling fins.

(b) Remove light corrosion with number 00 grit abrasive paper.

(c) Repair leaks and cracked or broken brazing by brazing or soldering.

(7) Replace radiator if damaged beyond repair.

### 3-28. SHUTTER ASSEMBLY.

**Removal.** Refer to the Operator and Organizational Maintenance Manual for shutter removal instructions.

**b. Disassembly.**

(1) Remove spring (1, figure 3-25).

(2) Remove cotter pin (2) to remove retainer (3) and spring (4).

(3) Remove retainer (5) to remove control lever (6).

(4) Remove any damaged or deteriorated seals (7) from vanes of shutter (8).

**c. Cleaning, Inspection, and Repair.**

(1) Clean all parts in dry cleaning solvent (Federal Specification P-D-680) and dry thoroughly.

(2) Visually inspect springs for cracks, breaks, and distortion.

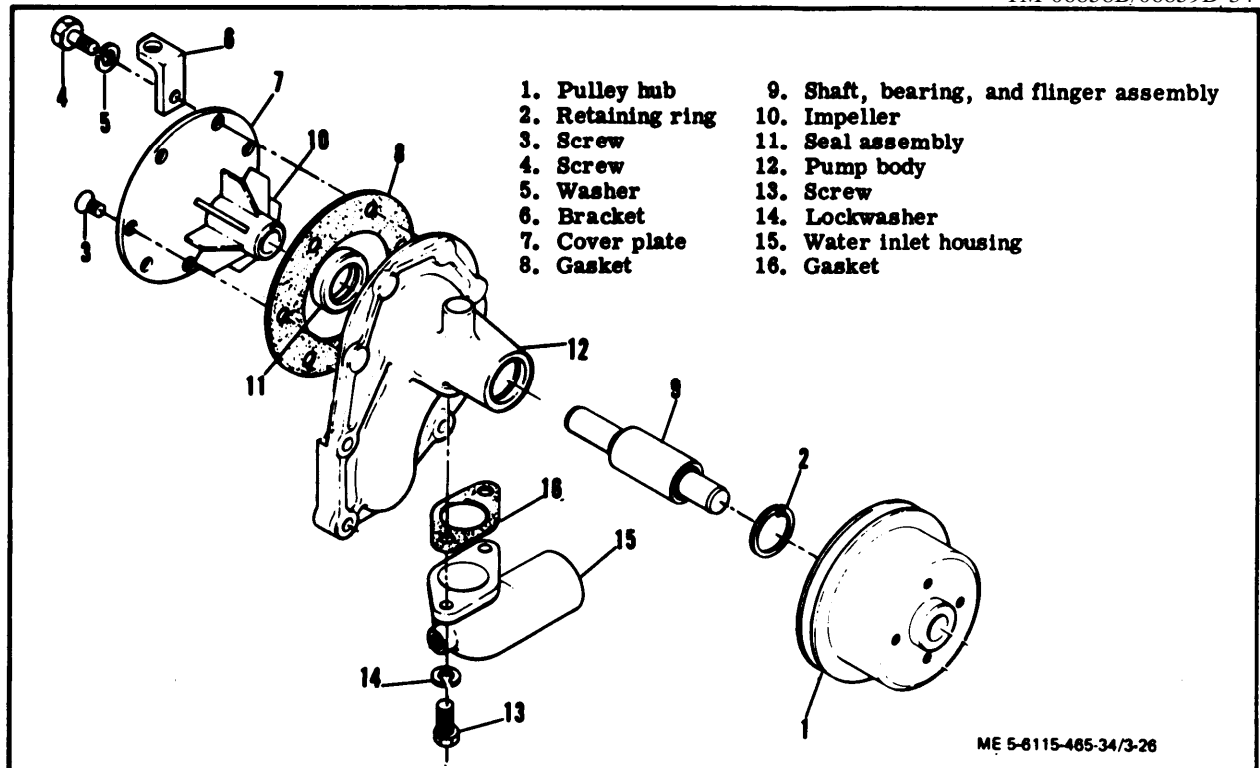

Figure 3-26. Water Pump Assembly, Exploded View

(3) Inspect control lever for cracks, bends, and excessive-wear.

(4) Inspect seals for damage and deterioration.

(5) Inspect shutter for bent or damaged vanes and support brackets, defective paint and other damage.

(6) Straighten bent control rod.

(7) Remove defective paint, treat, and repaint.

(8) Replace any parts damaged beyond repair.

d. Assembly. Assemble shutter assembly in reverse order of disassembly procedures.

e. Installation. Refer to the Operator and Organizational Manual for shutter assembly installation procedures.

### 3-29. COOLING FAN.

Refer to the Operator and Organizational Maintenance Manual for cooling fan maintenance procedures.

### 3-30. WATER PUMP.

a. Removal. Refer to the Operator and Organizational Maintenance Manual for cooling fan maintenance procedures.

b. Disassembly.

(1) Using a suitable puller, remove pulley hub (1, figure 3-26).

(2) Remove retaining ring (2).

(3) Remove screws (3 and 4), lockwasher (5) and bracket (6) to remove cover plate (7) and gasket (8).

(4) Support front end of pump in bed of arbor press and press shaft bearing and flinger assembly (9) from impeller (10), seal assembly (11), and pump body (12).

#### NOTE

Shaft, bearing and flinger assembly (9) is a unit. Do not attempt to disassemble.

(5) Press seal assembly (11) from pump body. Discard seal.

(6) Disconnect water inlet housing (15) by removing screw (13) and lockwasher (14). Discard gasket (16).

c. Cleaning, Inspection and Repair.

(1) Clean all parts in dry cleaning solvent (Federal Specification P-D-680) and dry thoroughly.

(2) Visually inspect cooling fan pulley for cracks, corrosion, and excessive wear.

(3) Check pulley hub for cracks, corrosion, and other damage.

(4) Inspect cover plate for cracks, corrosion, and rub marks on inner face.

(5) Inspect pump body for cracks, breaks, and excessive wear.

(6) Inspect shaft and bearing assembly for deep wear patterns, scores, pitting and other damage. Rotate bearing on shaft. If bearing is binding or feels rough, the shaft and bearing assembly must be replaced.

(7) Check impeller for erosion, cracking, and other damage.

(8) Replace any damaged or defective parts.

d. Assembly.

**CAUTION**

When installing seal, press on outer flange to avoid damaging the seal

(1) Press replacement seal (11) into pump body (12).

**CAUTION**

When installing shaft and bearing assembly, press on outer bearing face and not on end of shaft.

(2) Press shaft, bearing and flinger assembly (9) into pump body and install retaining ring (2).

(3) Support pump on outer end of shaft and press impeller (10) onto shaft, bearing and flinger assembly to obtain 0.010 inch clearance between impeller and cover plate (figure 3-27).

(4) Install gasket (8) and cover plate (7) and secure with screws (3). Install bracket (6) with screw (4) and washer (5).

(5) Press pulley hub (1) onto shaft (9) until shaft is flush with front of pulley.

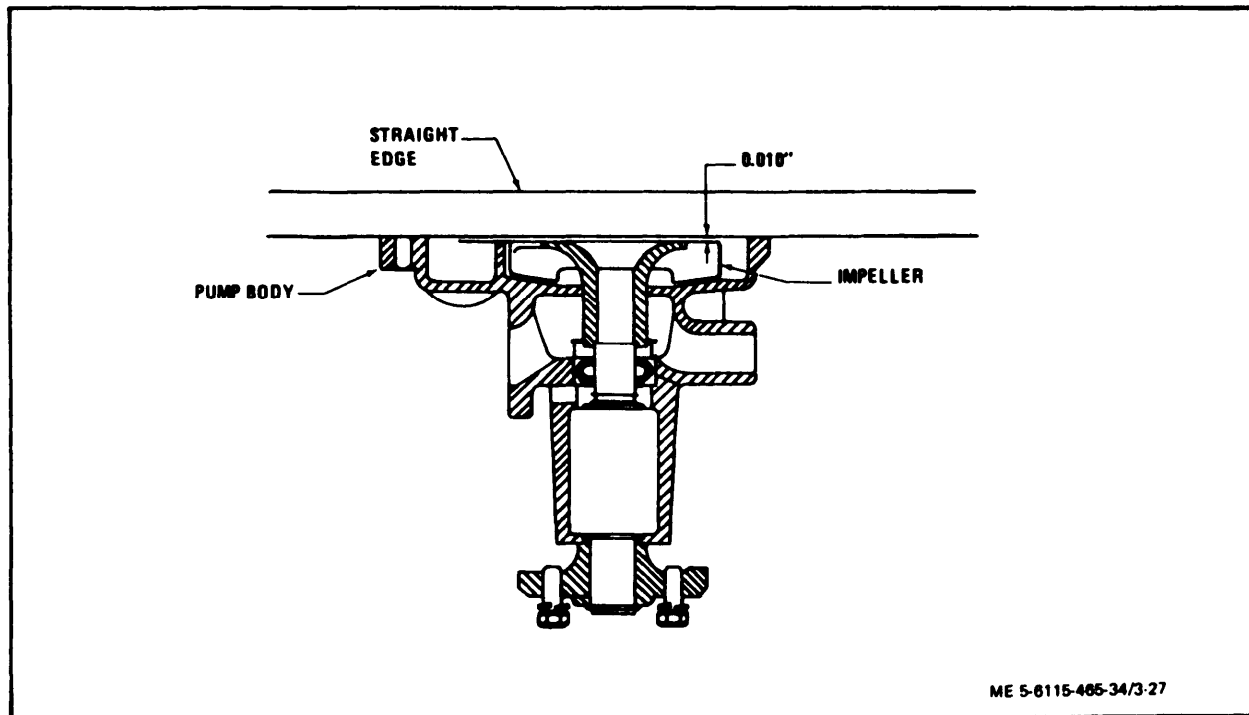

Figure 3-27. Checking Impeller to Cover Plate Clearance

(6) Install water inlet housing (15) and new gasket (16) with screws (19) and lockwasher (14).

Installation. Refer to the Operator and Organizational Maintenance Manual for water pump installation procedures.

### 3-31. COOLANT THERMOSTAT AND HOUSING.

Refer to the Operator and Organizational Maintenance Manual for coolant thermostat and housing maintenance procedures.

## Section Iv. ENGINE LUBRICATION SYSTEM

### 3-32. GENERAL.

The engine oil pan serves as a reservoir for lubricating oil. It is equipped with a bayonet type gauge for checking the all level in the pan. Oil is drawn into a gear type, positive displacement pump through a screen which prevents the entry of coarse abrasives. The oil pump forces the oil through a full flow type oil filter which removes minute abrasives. From the oil filter, the oil flows into the header, a drilled passage in the cylinder block, from which it is distributed to the internal engine components. A pressure transmitter measures oil pressure in the header and transmits it electrically to the oil pressure gauge. Header oil pressure is also measured by a low oil pressure switch which shuts down the engine if oil pressure falls to a dangerously low level.

### 3-33. LUBRICATION OIL FILTER.

Refer to the Operator and Organizational Maintenance Manual for lubrication oil filter maintenance procedures.

### 3-34. OIL LEVEL GAUGE.

Refer to the Operator and Organizational Maintenance Manual for oil level gauge maintenance procedures.

### 3-35. OIL COOLER ASSEMBLY (400 Hz Sets Only)

#### a. Removal.

(1) Refer to the Operator and Organizational Maintenance Manual and drain the engine lubrication system.

(2) Remove the plug (1, figure 3-28) from the oil filter assembly (2) and allow the 011 to drain into a suitable container.

(3) Disconnect hoses (3) from the oil cooler assembly.

(4) Open band clamps (6) and remove oil cooler assembly (7).

#### b. Cleaning, Inspection, and Repair.

(1) Clean oil cooler assembly in dry cleaning solvent (Federal Specification P-D-680) using a stiff bristle brush as necessary to remove caked deposits.

(2) Flush the interior of the oil cooler assembly to remove sludge deposits.

(3) Visually inspect the oil cooler assembly for cracks, bent cooling fins, corrosion, stripped threads and other damage.

(4) Straighten bent cooling fins and remove minor corrosion with fine grit abrasive paper.

(5) Repair minor thread damage with a thread chaser.

(6) If cracks, heavy corrosion and other damage is present, replace the oil cooler assembly.

#### c. Installation.

(1) Install 011 cooler assembly and tighten band clamps.

(2) Connect hoses to the oil cooler assembly.

(3) Refer to the Operator and Organizational Maintenance Manual and service the lube oil filter.

### 3-36. OIL PAN ASSEMBLY.

#### a. Removal.

(1) If generator set has winterization kits installed, refer to Operator and organizational Maintenance Manual and remove kits.

(2) Remove oil level gauge (1, figure 3-29).

(3) Remove elbow (7) from oil pan.

(4) Remove screws (2) and lockwashers (3) to lower oil pan (4) and remove gaskets (5), and seals (6). Discard seals and gaskets. Refer to paragraph 3-37 and remove oil pump assembly. Remove oil pan.

#### b. Cleaning, Inspection, and Repair.

(1) Clean all parts with dry cleaning solvent (Federal Specification P-D-680) and a stiff bristle brush. Dry thoroughly with filtered, compressed air.

(2) Scrape gasket remains from oil pan and cylinder block mating surfaces.

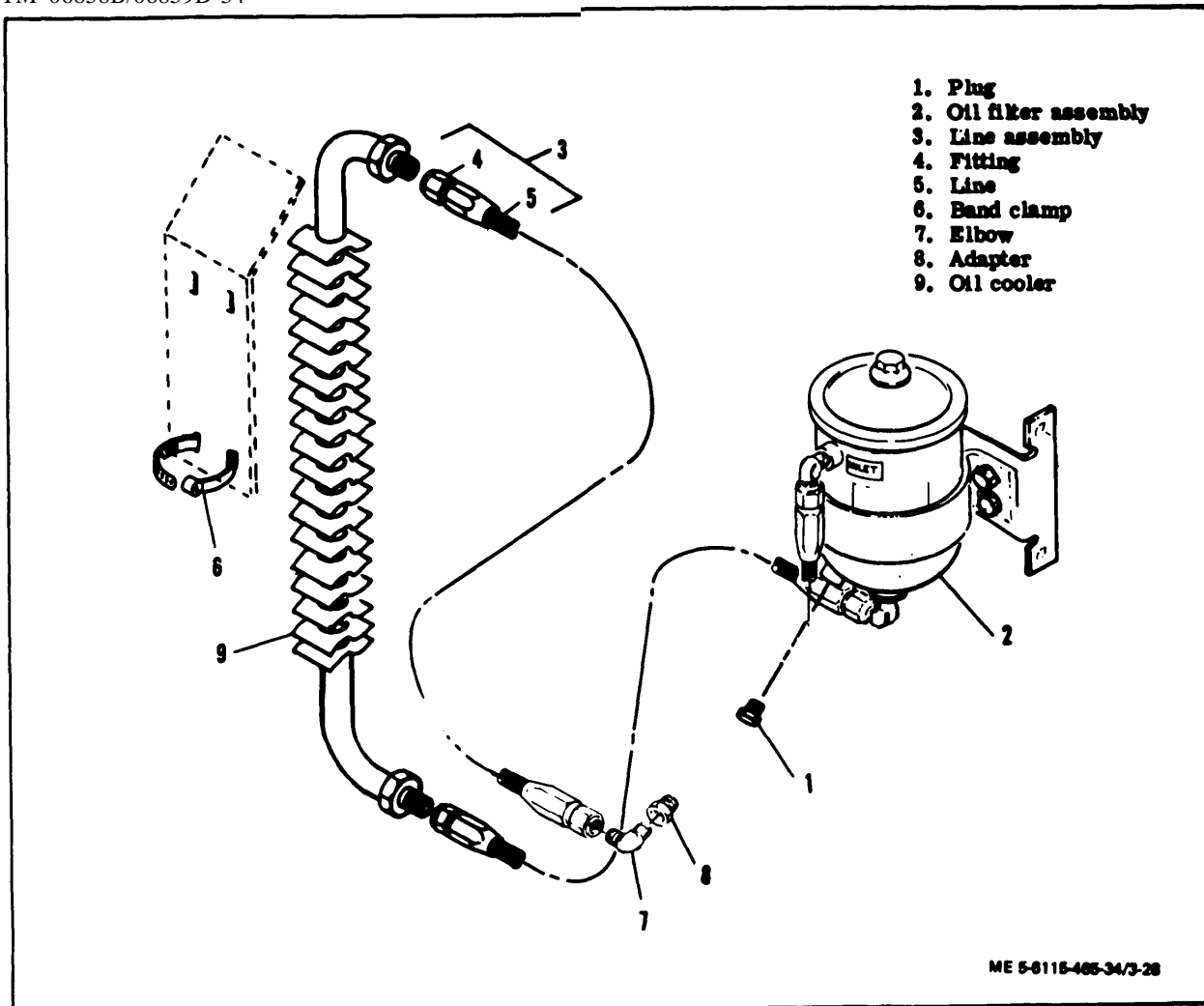

Figure 3-28. Oil Cooler Assembly Removal and Installation

(3) Inspect and replace oil level gauge in accordance with instructions provided in the Operator and Organizational Maintenance Manual.

(4) Inspect oil pan for cracks, dents, broken welds and leaks.

(5) Check all threads for crossing, stripping and peening.

(6) Repair cracks and broken welds in oil pan by welding.

(7) Repeat minor thread damage with a thread chaser.

(8) Replace any parts damaged beyond repair.

c. Installation. Using new gaskets and seals, install oil pan assembly in reverse order of removal procedures.

3-37. OIL PUMP ASSEMBLY.

a. Removal.

(1) Remove oil pan assembly (paragraph 3-36).  
 (2) Remove screws (1, figure 3-30) and lock-washers (2) to remove oil pump.

b. Disassembly.

(1) Remove oil pickup screen (3).  
 (2) Remove pressure relief valve (4), lock-washers (5) and seal (6). Discard seal.

CAUTION

Spring is under tension. Use care when removing roll pin.

(3) Remove roll pin (7) and withdraw retainer (8), spring (9) and plug (10) from valve body (11).



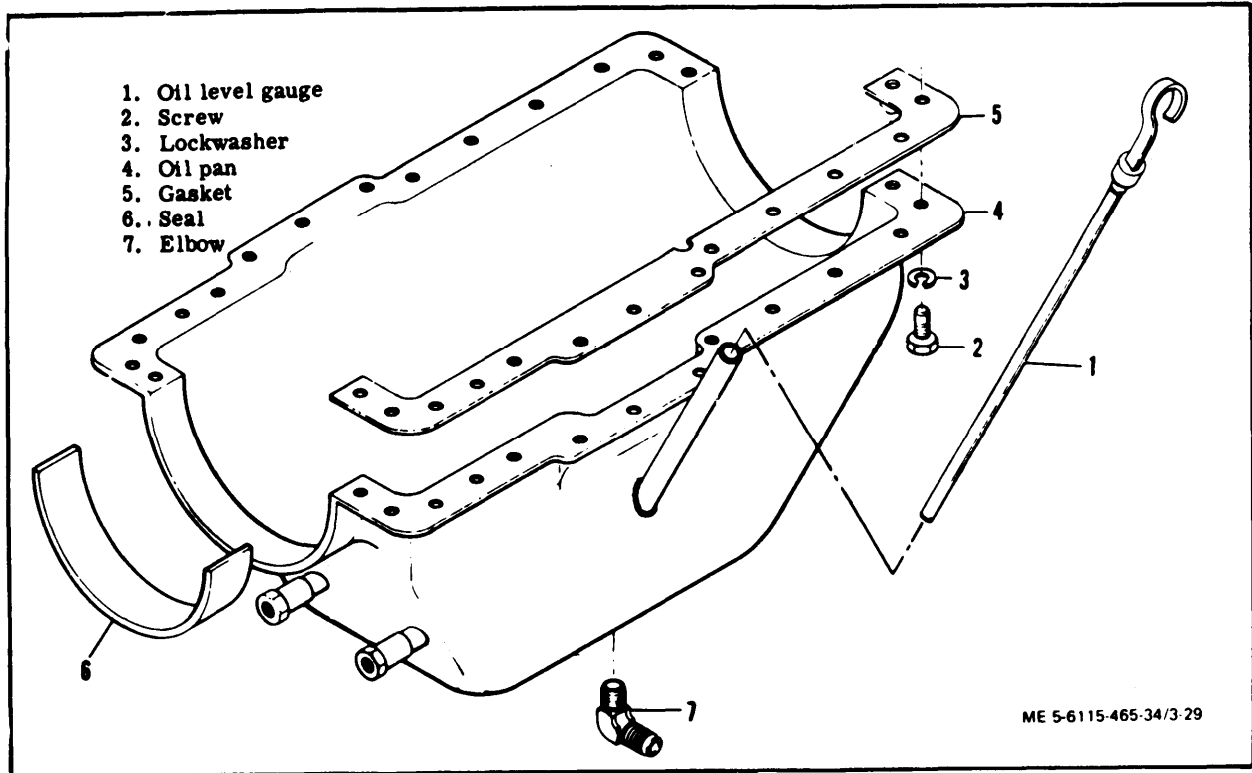

Figure 3-29. Oil Pan Assembly

- (4) Using a suitable puller, remove gear (12).
  - (5) Remove screws (13 and 15) and lockwashers (14 and 16) to remove cover plate (17).
  - (6) Remove driven gear (18).
  - (7) Withdraw drive gear (19) and drive shaft (20) as a unit. Press gear from shaft.
  - (8) Press shaft (21) from pump body (22).
- c. Cleaning, Inspection, and Repair.
- (1) Clean all parts in dry cleaning solvent (Federal Specification P-D-680) and dry thoroughly.
  - (2) Inspect spring (9, figure 3-30) for cracks, breaks and distortion.
  - (3) Inspect plunger (10) and bore of valve body (n) for scores, scratches, and deep wear patterns. Check that plunger moves freely in valve body.
  - (4) Check gear (12) for chipped or broken teeth, excessive wear, or other damage.
  - (5) Inspect cover plate for cracks and warpage. Check inner face for deep wear marks or scores from contact with gears.
  - (6) Inspect gears (18 and 19) for chipped or broken teeth, excessive wear or other damage.
  - (7) Inspect shafts (20 and 21) for cracks, scores and deep wear patterns. Check that shaft (20) rotates freely in pump body. Check that gear (18) rotates freely on shaft (21).
  - (8) Inspect pump body (22) for cracks, breaks, and other damage. Check gear bores for rub marks from contact with pumping gears.
  - (9) Check all threads for crossing, stripping or peening.
  - (10) Inspect screen (3) for rips, tears, breaks and clogging.
  - (11) Repair minor thread damage with a thread chaser.
  - (12) Remove minor nicks and burrs with crocus cloth and oil. Clean the part in dry cleaning solvent and dry thoroughly with filtered compressed air.
  - (13) Replace any parts worn or damaged beyond repair.
- d. Assembly.
- (1) Press drive gear (19, figure 3-30) onto shaft (20).

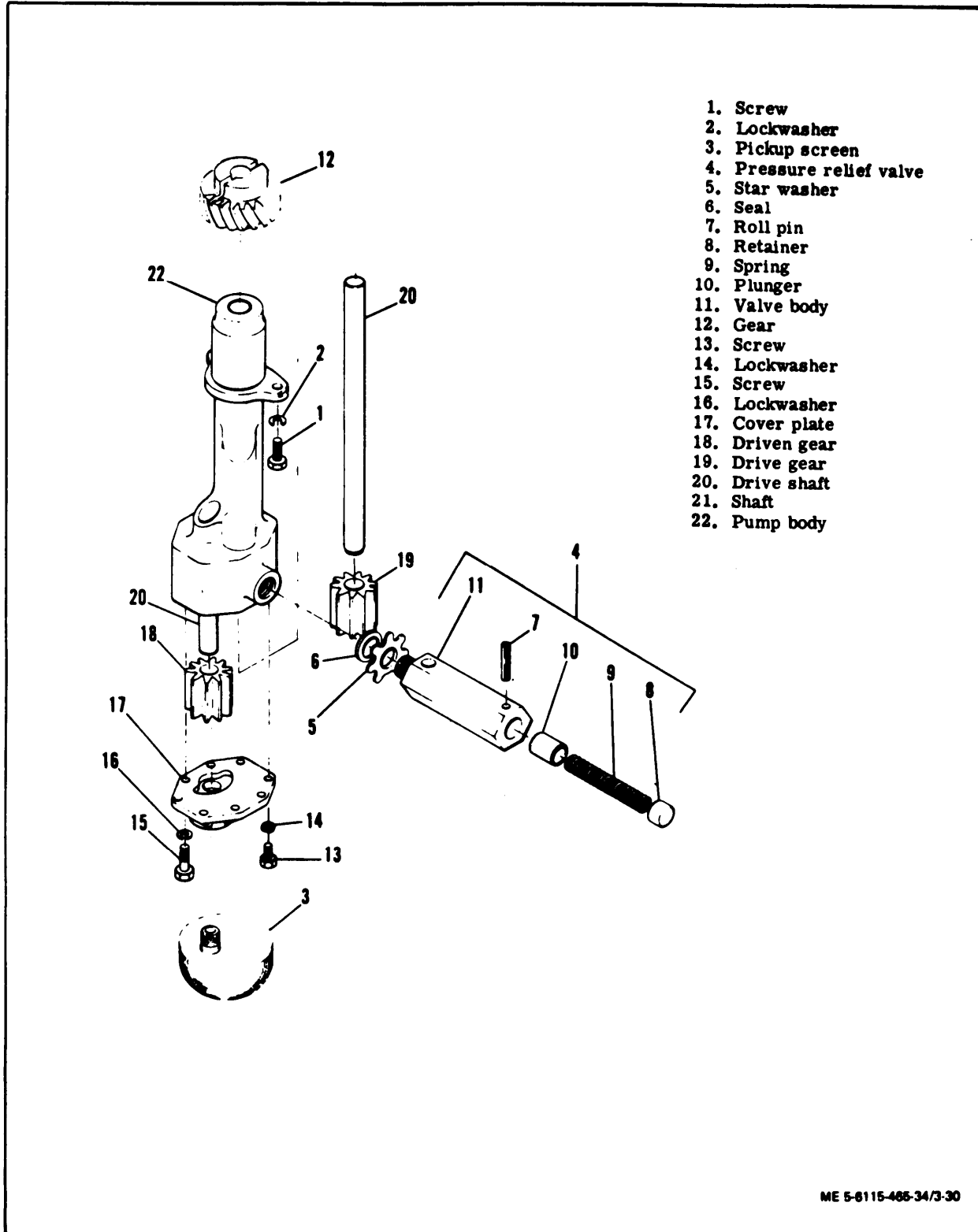

Figure 3-30. Oil Pump Assembly, Exploded View

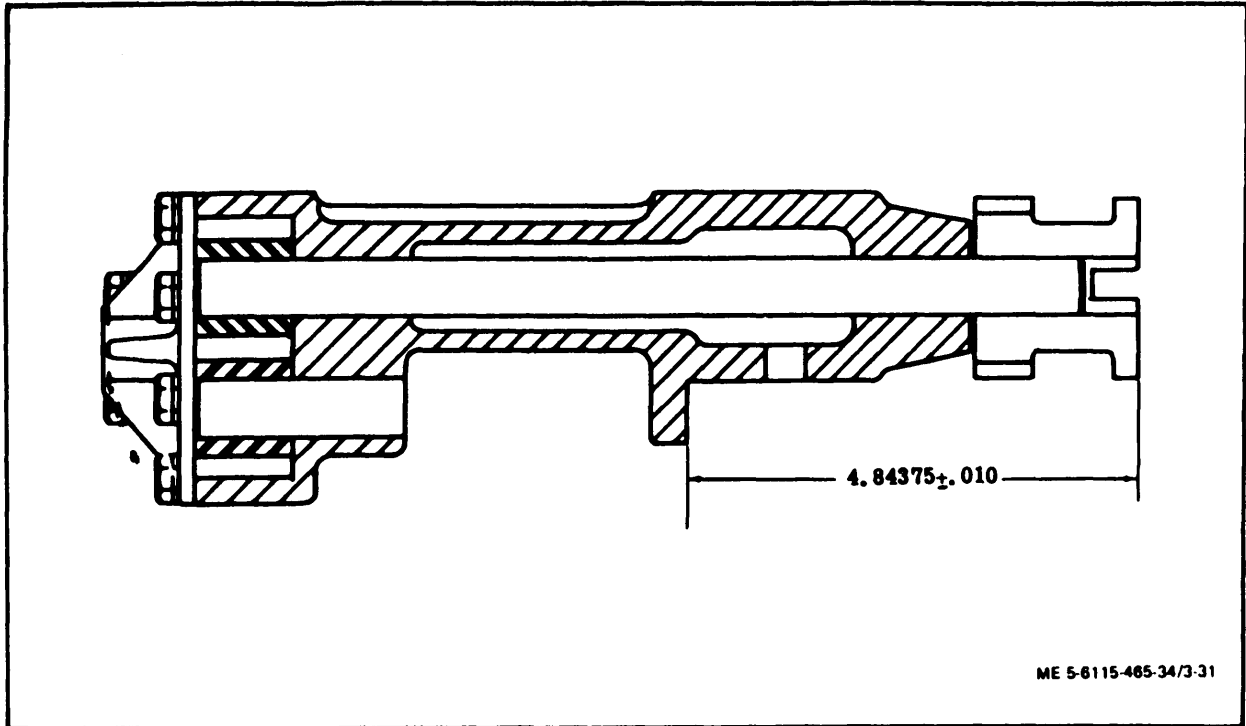

Figure 3-31. Oil Pump Assembly Dimension

(2) Insert shaft into pump body (22) and press gear (12) onto shaft until a dimension of  $4.84375 \pm 0.010$  inches is obtained between the mounting flange and the top of the drive flange (figure 3-31).

(3) Press shaft (21, figure 3-30) into pump body and install driven gear (18).

(4) Install cover plate (17) and secure with lockwashers (16 and 14) and screws (15 and 13).

(5) Insert plunger (10) into valve body (11). Install spring (9) and retainer (8) and secure with roll pin (7).

(6) Install new seal (6), lockwasher (5) and pressure relief valve (4).

(7) Check that drive shaft rotates freely. If shaft binds, disassemble pump and ascertain cause before installing.

(8) Install pickup screen (3) and tighten.

NOTE

Pickup screen must be in the horizontal position when the pump is installed in the engine.

e. Installation.

(1) Install oil pump, making sure that drive gear mates correctly with speed switch drive assembly.

(2) Install oil pan (paragraph 3-36).

## Section V. HYDRAULIC SYSTEM

### 3-38. GENERAL.

The hydraulic system used on MEP-104A sets only provides a means of precise frequency control on precise generator sets. The system consists of a sump, a replaceable element type filter, a gear type positive displacement pump and a hydraulic actuator unit. The hydraulic pump draws oil from the sump and forces it through the filter. From the filter, the oil flows to the hydraulic actuator unit. An electrically controlled set of valves alters the path of the oil which determines the positioning of the governor control linkage. The position of the governor control linkage determines the fuel pump governor setting, which sets engine speed. Changes in engine speed causes a corresponding increase or decrease in generator output frequency.

### 3-390 HYDRAULIC SUMP.

#### a. Removal.

(1) Refer to the Operator and Organizational Maintenance Manual and draft the hydraulic sump.

(2) Disconnect hydraulic lines (1, figure 3-32).

(3) Remove nuts (2), lockwashers (3) and screws (4) to remove hydraulic sump (5).

(4) Remove cap and dipstick assembly (6) and elbows (7) from sump.

#### b. Cleaning, Inspection, and Repair.

(1) Clean all parts in an approved solvent and dry thoroughly with filtered compressed air.

(2) Flush interior of sump with an approved solvent and dry thoroughly.

(3) Visually inspect hydraulic sump for cracked or broken welds, defective paint, illegible markings, and dents.

(4) Inspect cap and dipstick assembly for corrosion, bent dipstick, and other damage.

(5) Check all threads for crossing, stripping, and peening.

(6) Test hydraulic sump for leaks as follows:

(a) Securely install cap and dipstick assembly.

(b) Install a plug in outlet connection.

(c) Install a fitting in inlet opening and connect an air line.

(d) Submerge hydraulic sump in a container of water and pressurize at 10 to 15 psig air pressure.

(e) Check for air bubble formations which will indicate leaks.

(f) Remove hydraulic sump from container. Release air pressure. Thoroughly dry exterior prior to removing cap and dipstick assembly, plug, or fitting in prevent entry of water into hydraulic sump.

#### CAUTION

Steam clean the interior of the sump for a period of 2 hours to remove residual vapors prior to welding.

(7) Repair leaks and cracked or broken welds by welding.

(8) Test repairs as outlined in step (6) above.

(9) Remove defective paint, treat, and repaint.

(10) Markings shall be in accordance with using service requirements.

(11) Repair minor thread damage with a thread chaser.

(12) Replace any excessively damaged parts.

#### c. Installation.

(1) Install elbows (7, figure 3-32).

(2) Install cap and dipstick assembly (6) in hydraulic sump (5) and secure with screws (4), lockwashers (3) and nuts (2).

(3) Connect hydraulic lines (1).

### 3-40. HYDRAULIC PUMP ASSEMBLY.

#### a. Removal.

(1) Refer to the Operator and Organizational Maintenance Manual and drain the hydraulic sump.

(2) Remove hydraulic lines and fittings from hydraulic pump assembly.

(3) Remove lockwires (1, figure 3-33), screws (2) and flat washers (3) to remove hydraulic pump assembly and gasket (4). Discard gasket.

b. Disassembly. Disassemble hydraulic pump assembly (items 5 through 31) as required to clean, inspect and replace parts.

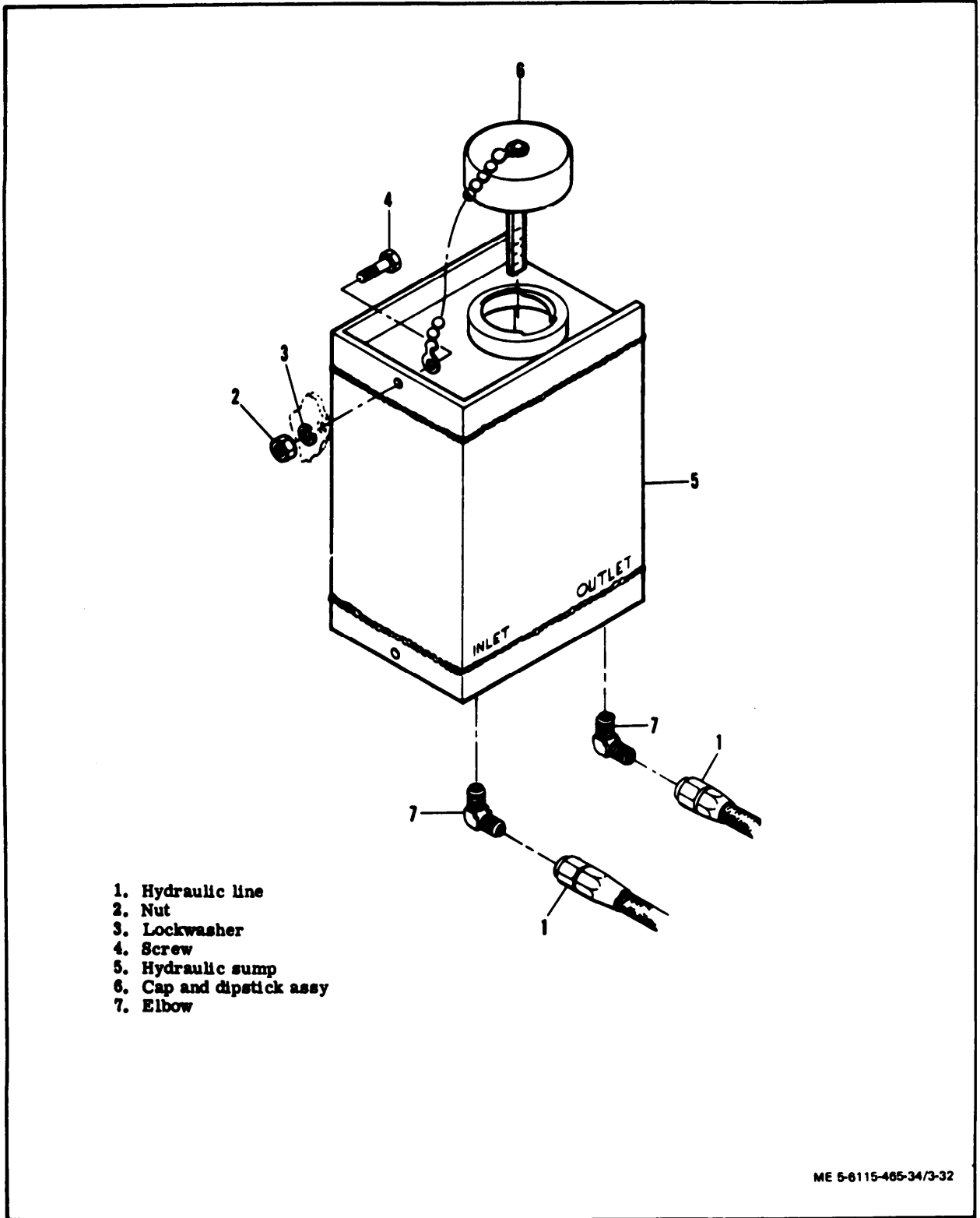
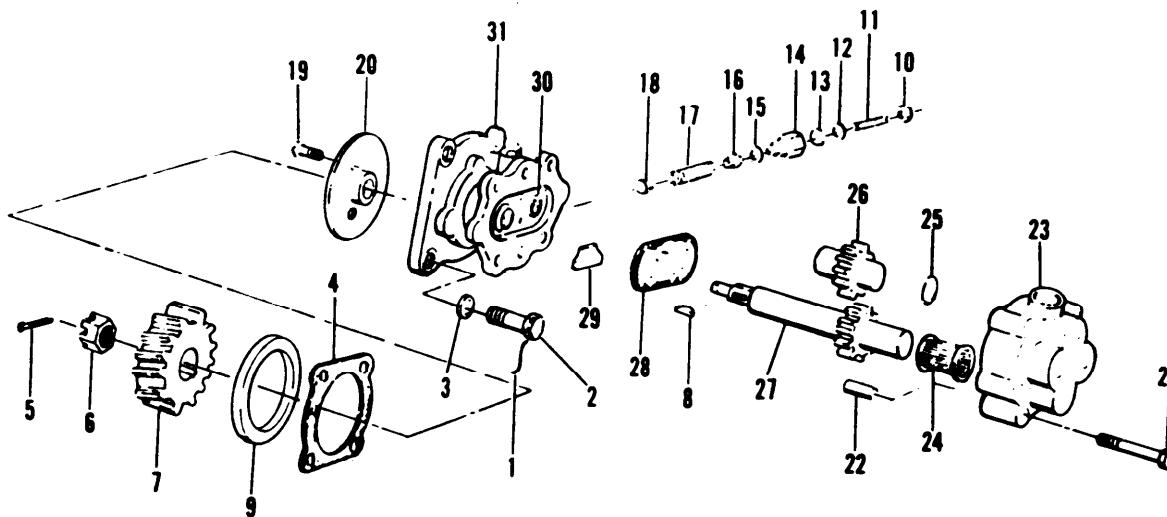

Figure 3-32. Hydraulic Sump, Removal and Installation

1. Lockwire
2. Screw
3. Flat washer
4. Gasket
5. Cotter pin
6. Castellated nut
7. Drive gear
8. Woodruff key
9. Adapter
10. Locknut
11. Pressure setscrew
12. Flat washer
13. Sealing washer
14. Pressure valve block
15. O-ring
16. Valve plug
17. Spring
18. Flange eyelet
19. Screw
20. Seal plate
21. Screw
22. Dowel pin
23. Cover
24. Needle bearing
25. O-ring
26. Idler gear
27. Drive shaft and gear assy
28. Plate and seal assy
29. Check valve
30. Needle bearing
31. Body



ME 5-6115-465-34/3-33

Figure 3-33. Hydraulic Pump Assembly, Exploded View

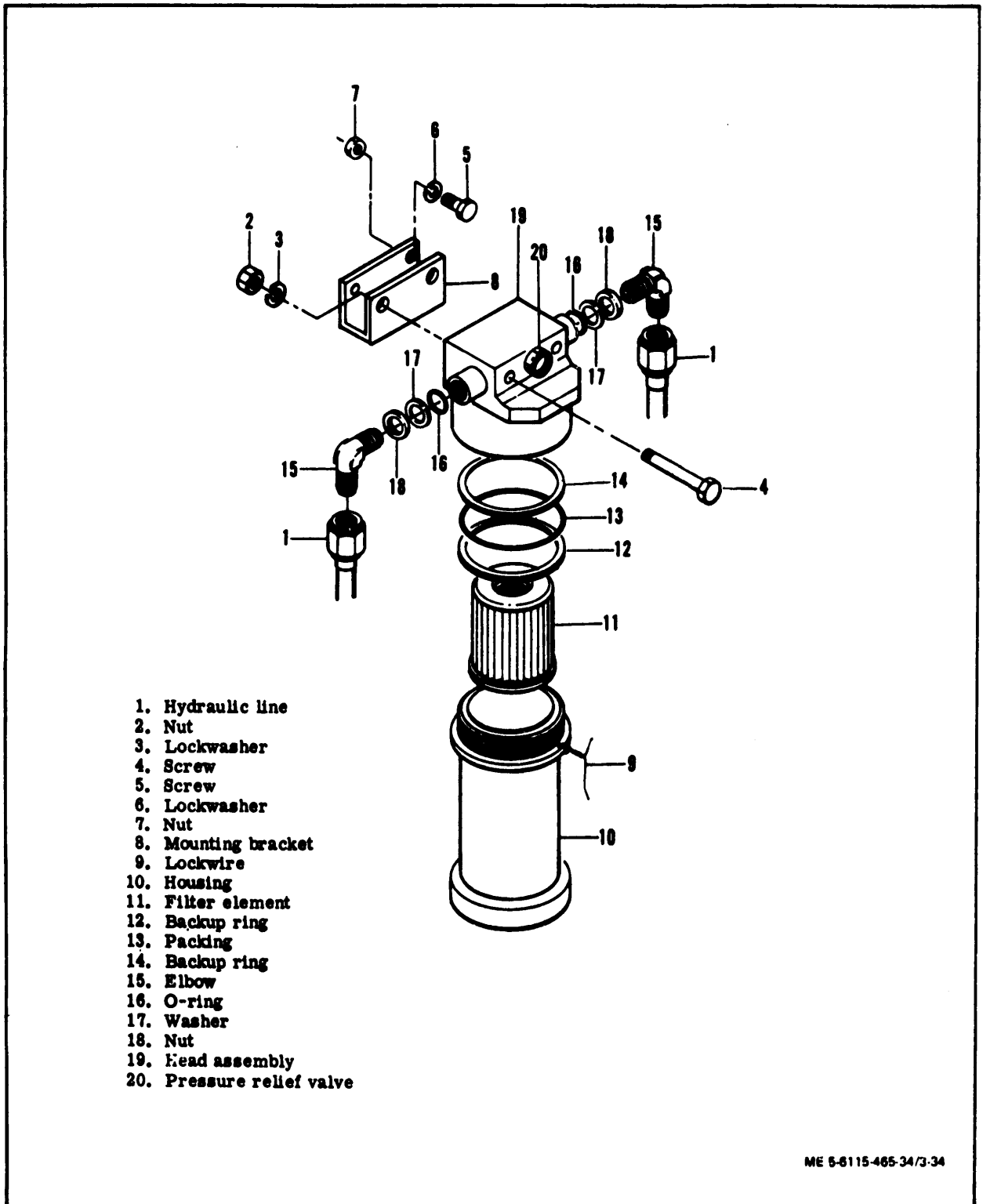

Figure 3-34. Hydraulic System Filter Assembly, Exploded View

c. Cleaning, Inspection, and Repair.

(1) Clean all parts in dry cleaning solvent (Federal Specification P-D-680) and dry thoroughly.

(2) Inspect drive gear for cracks and worn, chipped, or broken teeth.

(3) Inspect adapter for deep wear marks, cracks, and galling.

(4) Inspect pressure valve block and valve plug for corrosion, wear and galling.

(5) Check spring for chaffing, cracks, and distortion.

(6) Inspect flange eyelet and valve seat for wear, cracks, and galling.

(7) Inspect drive shaft and gear assembly and idler gear for cracks, deep wear patterns, and other damage.

(8) Inspect body and cover for cracks, corrosion, deep wear patterns in gear bores.

(9) Replace all bearings, seals, gaskets, and o-rings at each overhaul.

(10) Replace any damaged parts.

d. Assembly. Assemble hydraulic pump in reverse order of disassembly procedures, installing new o-rings, gaskets, and seals.

e. Testing.

(1) Install hydraulic pump assembly on a suitable test stand and provide a means of rotating at approximately 600 RPM.

(2) Connect a hydraulic line to pump assembly inlet.

(3) Connect a hydraulic line equipped with a pressure gauge, and a restriction valve to the pump assembly outlet.

(4) Operate pump at approximately 600 RPM.

(5) Close restriction valve until pressure gauge reads  $320 + 10$  PSI. If  $320 \pm 10$  PSI is not obtainable, loosen locknut and adjust pressure relief valve screw until  $320 \pm 10$  PSI is reached.

(6) Slowly close the restriction valve while observing the pressure gauge. The pressure should drop. If not, continue to adjust pressure relief valve screw until pressure does drop.

(7) Loosen locknut and adjust pressure set-screw (11, figure 3-33) until pressure gauge indicates  $320 \pm 10$  psig.

(8) Tighten locknut and remove hydraulic pump assembly from test hookup.

f. Installation. Install hydraulic pump assembly in reverse order of removal procedures, installing new gaskets, o-rings, and seals.

3-41. HYDRAULIC SYSTEM FILTER ASSEMBLY.

a. Removal.

(1) Disconnect hydraulic lines (1, figure 3-34) and drain hydraulic fluid into a suitable container.

(2) Remove nuts (2), lockwashers (3) and screws (4) to remove filter assembly.

(3) Do not remove screws (5), lockwashers (6), nuts (7) and mounting bracket (8) unless inspection reveals damage.

b. Disassembly.

(1) Remove lock wire (9) and unscrew housing (10).

(2) Remove and discard filter element (11), backup ring (12), packing (13) and backup ring (14).

(3) Remove elbows (15), o-rings (16), washers (17) and nuts (18) from head assembly (19). Discard o-rings.

(4) Do not remove pressure relief valve (20).

c. Cleaning, Inspection, and Repair.

(1) Clean all parts in dry cleaning solvent (Federal Specification P-D-680) and dry thoroughly with filtered compressed air.

(2) Visually inspect mounting bracket for cracks, breaks and corrosion.

(3) Inspect housing for cracks, corrosion, and other damage.

(4) Inspect head assembly for cracks, breaks, and corrosion. Check parts for deposits of foreign material. Remove any deposits found.

(5) Check all threads for crossing, stripping, and peening. Repair minor thread damage with a thread chaser.

(6) Replace any damaged or defective parts.

d. Assembly. Assemble hydraulic system filter assembly in reverse order of removal procedures.

NOTE

Soak replacement filter element in oil conforming to Military Specification MIL-H -5606 to remove trapped air before installing.



1. Electrical connector
2. Electrical connector
3. Hydraulic line
4. Hydraulic line
5. Nut
6. Bolt
7. Nut
8. Screw
9. Rod end
10. Locknut
11. Threaded rod
12. Bolt
13. Lockwasher
14. Hydraulic actuator unit

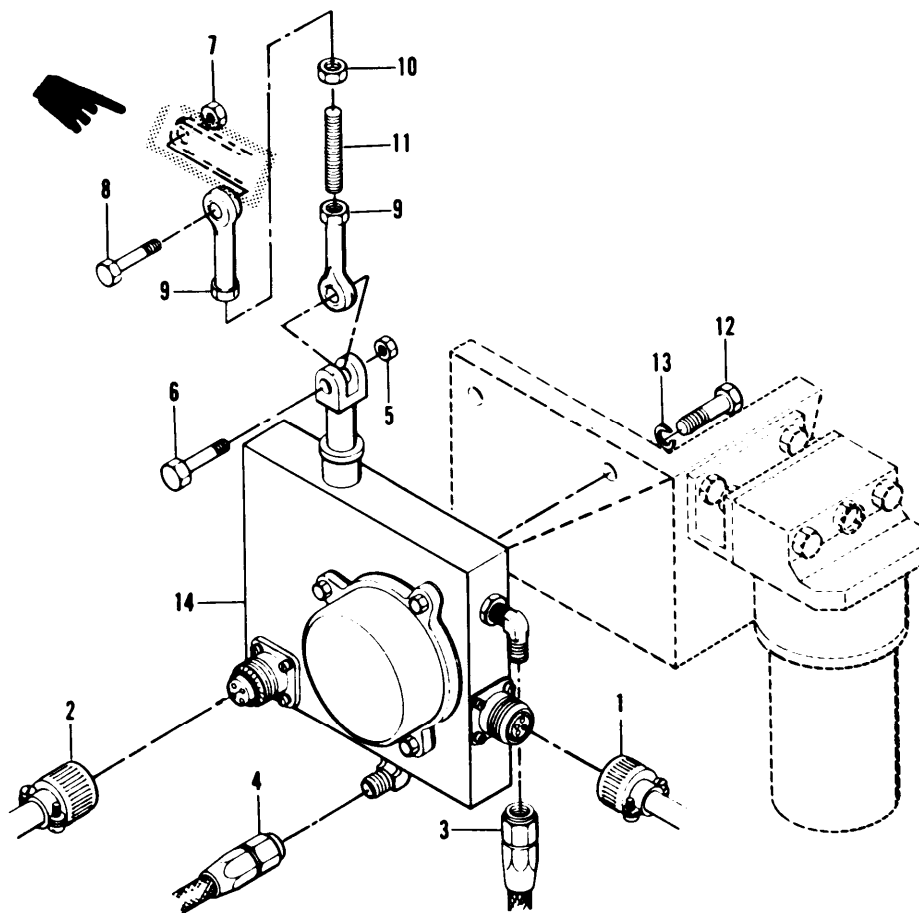

ME5-6115-465-34/3-35

Figure 3-35. Hyderaulic Actuator Unit, Removal and Installation

TMS-6115-465-  
 NAVFAC P-8-62  
 T.O. 35C2-3-4  
 TM 06858B/068

e. Installation. Install hydraulic system filter in reverse order of removal procedures.

### 3-42. HYDRAULIC ACTUATOR UNIT.

#### a. Removal.

(1) Refer to the Operator and Organizational Maintenance Manual and drain the hydraulic tank.

(2) Disconnect electrical connectors (1 and 2, figure 3-35) and hydraulic lines (3 and 4).

(3) Remove nut (5) and bolt (6).

(4) Do not remove nut (7), bolt (8), rod ends (9), locknut (10), and threaded rod(n) unless inspection reveals damage.

(5) Remove bolts (12) and lockwashers (13) to remove actuator unit (14).

#### b. Disassembly.

#### NOTE

Test hydraulic actuator unit in accordance with sub-paragraph f. below prior to disassembly.

(1) Remove elbow (1, figure 3-36), adapter (2), and o-ring (3).

(2) Remove elbow (4), adapter (5), filter assembly (6), and o-ring (7).

(3) Remove screw (8) and lockwasher (9).

(4) Loosen setscrew (10) and remove link (11).

(5) Remove transducer slug (12),

(6) Remove retaining ring (13), washer (14), o-ring (15), collar (16), and quad-ring collar (17). Discard o-rings.

(7) Remove clevis (18), retaining ring (19), washer (20), o-ring (21), collar (22) and quad-ring collar (23). Discard o-ring.

(8) Remove piston (24).

(9) Remove setscrew (25), screw (26), and lockwasher (27) to remove electrical connector (28) and split spacer (29).

(10) Remove transducer (30).

(11) Do not remove roll pin (31) unless damage is present.

(12) Remove plugs (32) and o-rings (33). Discard o-rings.

(13) Remove screws (34) and lockwashers (35) to remove electrical connector (36) and gasket (37). Discard gasket.

(14) Remove screws (38) and lockwashers (39) to remove cover (40) and gasket (41). Discard gasket.

(15) Remove screws (42) and lockwashers (43) to remove armature core (44) from valve block (45).

(16) Remove valve needles (46), top orifices (47), o-rings (48), valves (49), spacers (50), bottom orifices (51) and o-rings (52). Discard o-rings.

(17) Remove screws (53) and lockwashers (54) to remove adapters (55) with attached parts and pin springs (56).

(18) Remove screws (57), lockwashers (58), and nuts (59) to remove mounting plates (60).

(19) Remove screws (61), lockwashers (62), and nuts (63) to remove armature (64). Remove locknuts (65) and setscrews (66) from armature.

(20) Remove screws (67) and lockwashers (68) to remove coils (69).

#### c. Cleaning, Inspection, and Repair.

(1) Clean all non-electrical parts in dry cleaning solvent (Federal Specification P-D-680) and dry thoroughly with filtered compressed air.

(2) Clean all electrical parts with a clean, lint-free cloth lightly moistened with an approved solvent.

(3) Visually inspect collars, piston, and bore in valve block for nicks, burrs, scores, and other damage.

(4) Insert piston into valve block bore to ascertain that it moves freely.

(5) Inspect transducer slug and bore of transducer for nicks, burrs, scratches, and other damage. Remove minor nicks and burrs from transducer slug with crocus cloth.

(6) Inspect transducer for burns, discoloration and other indications of electrical malfunction. Check continuity of transducer using figure 3-37 as a guide.

(7) Inspect electrical connectors for cracks, bent or broken pins, and other damage.

(8) Inspect armature cores for cracks, corrosion, and burns or other indications of electrical malfunction. Check continuity of cores using figure 3-37 as a guide.

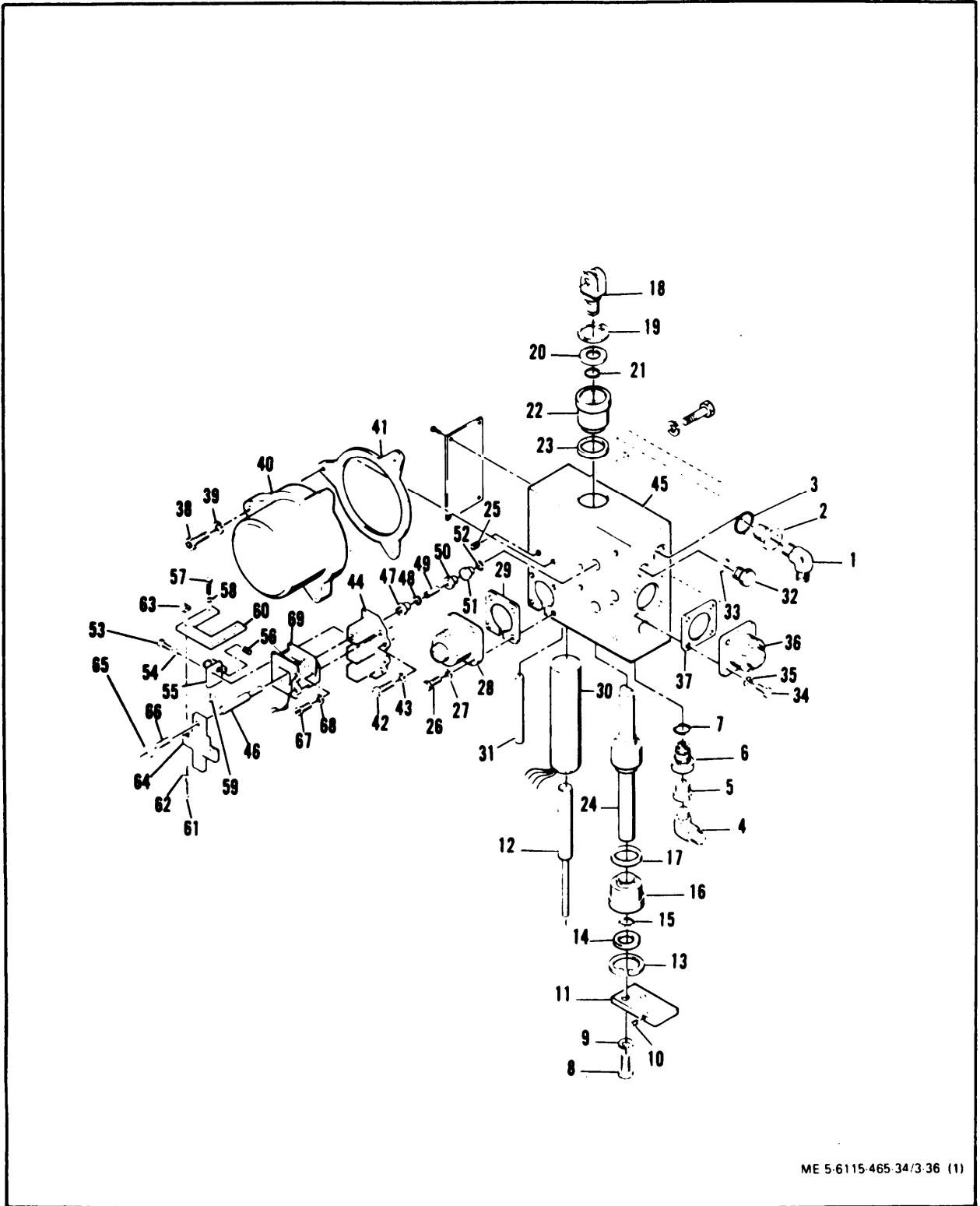

Figure 3-36. Hydraulic Actuator Unit, Exploded View (Sheet 1 of 2)

1. Elbow	36. Electrical connector
2. Adapter	37. Gasket
3. O-ring	38. Screw
4. Elbow	39. Lockwasher
5. Adapter	40. Cover
6. Filter assembly	41. Gasket
7. O-ring	42. Screws
8. Screw	43. Lockwasher
9. Lockwasher	44. Armature mounting (core)
10. Setscrew	45. Valve block
11. Link	46. Valve needle
12. Transducer slug	47. Top orifice
13. Retaining ring	48. O-ring
14. Washer	49. Valve
15. O-ring	50. Spacer
16. Collar	51. Bottom orifice
17. Quad ring collar	52. O-ring
18. Clevis	53. Screw
19. Retaining ring	54. Lockwasher
20. Washer	55. Adapter
21. O-ring	56. Pin spring
22. Collar	57. Screw
23. Quad ring collar	58. Lockwasher
24. Piston	59. Nut
25. Setscrew	60. Mounting plate
26. Screw	61. Screw
27. Lockwasher	62. Lockwasher
28. Electrical connector	63. Nut
29. Split spacer	64. Armature
30. Transducer	65. Lock nut
31. Roll pin	66. Setscrew
32. Plug	67. Screw
33. O-ring	68. Lockwasher
34* Screw	69. Coil
35. Lockwasher	

ME 56115-46534/3.36 (2)

Figure 3-36. Hydraulic Actuator Unit, Exploded View (Sheet 2 of 2)

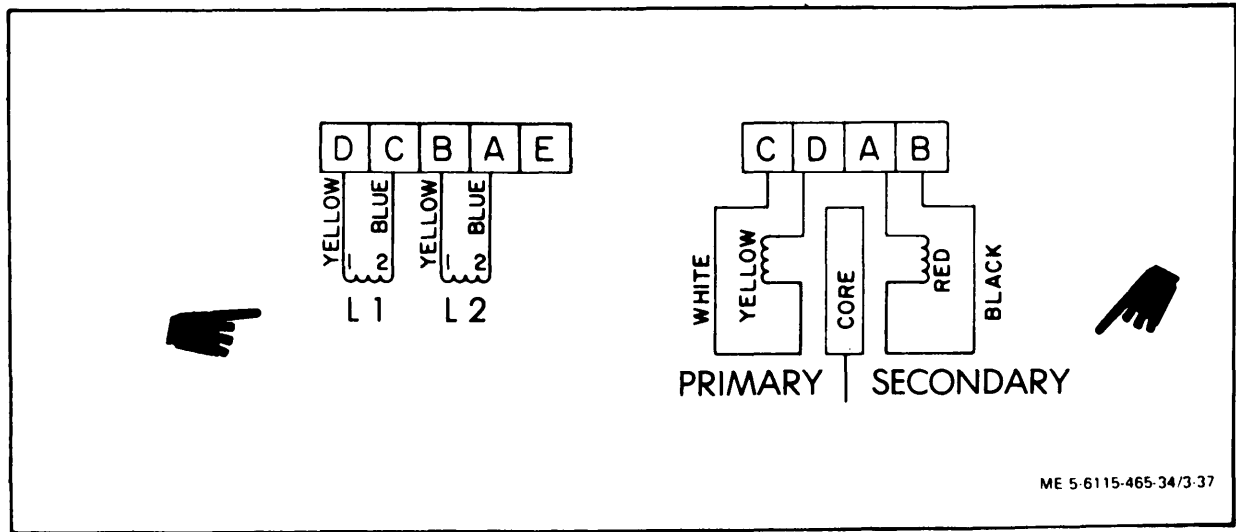

Figure 3-37. Transducer and Armature Coil Schematic Diagram

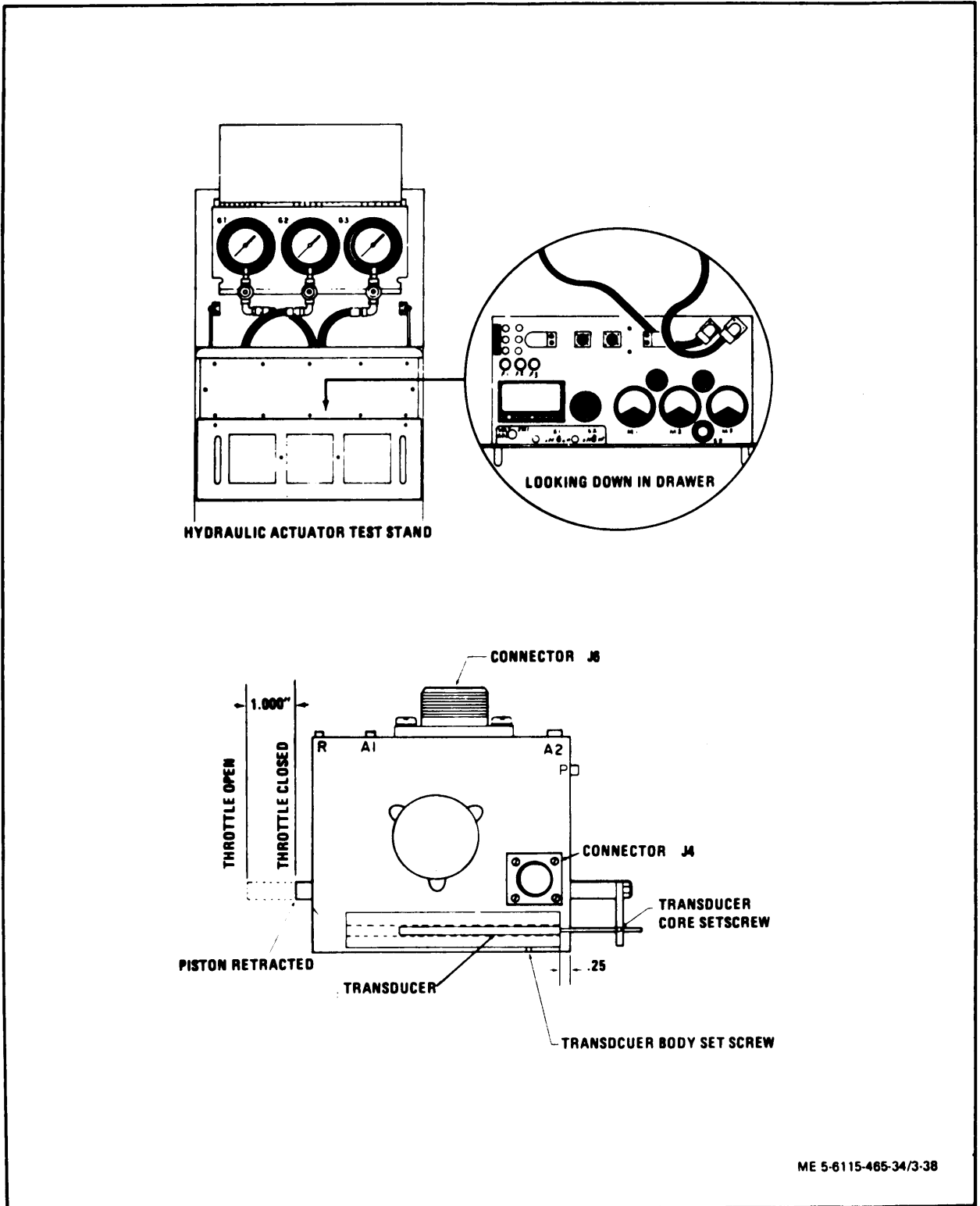

Figure 3-38. Hydraulic Actuator Test

(9) Inspect cover and valve block for cracks, corrosion, and other damage..

(10) Check all threads for crossing, stripping, and peening. Repair minor thread damage with a thread chaser.

(11) Inspect top and bottom orifices, spacer for nicks and burrs. Inspect 3 cornered valve for nicks and burrs on vertical edges that could cause binding depth of needle hole should be at least 0.125 inch. Inspection bottom face of valve (opposite needle hole) for grooving. The valve may be polished to remove grooves. After polishing the bottom face, the overall length of the valve must be at least 0.240 inch, if not, replace the valve.

(12) Inspect needles for burrs and any wear indications. Check for straightness by rolling large diameter end with finger slowly on a known flat surface; observe small diameter end while rolling, it must not move up and down, which indicates a bent needle. A bent needle, new or used, must be replaced as the pressure at A1 and A2 ports will vary and be difficult to adjust for correct values.

(13) Replace any damaged or defective parts.

d. Assembly. Assemble hydraulic actuator unit in reverse order of disassembly procedures, while observing the following:

(1) Install valves (49) with the hole in the up position to accept needles (46).

(2) Transducer body (30) must be installed 0.125 inch below outside edge of valve block. Secure body with setscrew (25).

e. Testing with test stands.

(1) Install hydraulic actuator unit in test stand as follows: (See figure 3-38).

(a) Connect hydraulic fluid supply from test stand gauge (G3) to actuator inlet port (P).

(b) Connect hydraulic fluid return line to actuator port (R).

(c) Connect test stand gauge (C1) to actuator unit test point (A1).

(d) Connect test stand gauge (G2) to actuator test point (A2).

(e) Connect connectors (P3) and (P4) of test stand electrical cable assemblies to actuator unit connectors (J6 and J4) respectively.

(2) Start the test stand.

(3) Beginning at position 1, rotate switch (S3) to each position and compare the readings with those of table 3-2.

(4) Place test stand switch (S2) in the off position to turn off hydraulic fluid pump.

(5) Place the actuator unit piston in the full fuel position and check indication on test stand meter (M1). Indication should be less than 3 volts.

(6) Place the actuator unit piston in the no fuel position and check indication on test stand meter (M1). Indication should be approximately 48-55 volts.

(7) Slowly, at an even rate, move the hydraulic actuator unit piston from the no fuel to the full fuel position while observing test stand meter (M1). The indication on meter should decrease; at an even rate, from approximately 50 volts to less than 3 volts. The indication should not change directions.

(8) Shut off test stand and remove the hydraulic actuator unit.

(9) If unit failed to meet test requirements, disassemble and ascertain cause. Retest prior to installation.

f. Testing without test stand.

(1) Actuator valve and piston test.

(a) See figure 3-38.1 to perform the valve and piston test.

(b) Connect dc power supply (ps) and switch (S1) to J6 as illustrated. Connect voltmeter (M1) with resistor (R1) to pins A and B of J4.

(c) Attach gage G1 and G2 as shown. Connect hydraulic power source (310 -320 psi, 2 gpm) and gage G3 and provide a return line from port R to the hydraulic sump.

(d) To adjust the valves, remove the large round cover and replace it with a similar diameter collar which will allow access to the adjustment screws and jam nuts. This is necessary to contain the hydraulic fluid which is ported within this cover.

(e) With hydraulic power but no electric power applied, adjust the valve with Allen set screw to yield 200 psi  $\pm$  10 psi at A1 port (gage G1) and 150 psi  $\pm$  10 psi at A2 port (gage G2). (See figure 3-38.1.)

CAUTION: Avoid overadjusting to prevent pressures or forces which could bend valve push rods.

(f) After adjusting, lock Allen adjusting screws with jam nuts, and install cover.

(g) Set S1 to the center position (solenoid coils in series). Apply 350  $\pm$  20 ma through the coils. Pressures at A1 and A2 ports shall remain the same (step (e) above).

(h) Set switch S1 to connect power (PS) to coil L2 and apply 700 ma  $\pm$  40 ma. Pressure at A1 port (gage G1) shall be 310 to 400 psi. Pressure at A2 port (gage G2) shall be 0 to 20 psi.

(i) Set switch S1 to connect power (PS) to coil L1 and apply 700 ma  $\pm$  40 ma. Pressure at A1 port (gage G1) shall be 0 to 40 psi and pressure at A2 port (gage G2) shall be 310 to 400 psi.

(2) Throttle Position Transducer Test.

(a) With voltmeter (M1), resistor (R1) and 120 (+ 1%, 60 Hz) power source connected as shown in figure 3-38.1, move piston to fully open throttle position.

(b) With the transducer body locked in place by its set screw, loosen the transducer core set screw and move the core relative to the body until a minimum voltage (0.5 to 2.5 volts) is obtained on the transducer secondary, as indicated on M1.

(c) Move the piston gradually towards the fully closed throttle position. The transducer secondary voltage, indicated by meter M1 shall increase in a linear manner to a maximum of 48 to 55 volts.

(d) Repeat these adjustments until the transducer secondary voltage increases linearly from the lowest possible value to a maximum value over the entire 1.0 inch displacement of the piston.

(e) When final adjustment is made, lock the transducer core in place with the transducer core set screw.

(f) Remove the gages, meter, and power supplies.

g. Installation and Final Adjustment.

(1) Install hydraulic actuator unit in reverse order of removal procedures.

NOTE

Leave governor linkage loose to accommodate adjustments.

(2) Place the generator set START-RUN-STOP switch in the RUN position.

CAUTION

Do not attempt to start the generator set.

(3) Place the generator set BATTLE SHORT switch in the override (ON) position.

(4) Beginning at the full counterclockwise position, rotate the fuel injection pump shutoff lever in the clockwise direction until a slight resistance is felt. Hold the shutoff lever in this position.

NOTE

This resistance is the fuel injection pump governor linkage hook engaging the metering valve arm.

(5) Move the hydraulic actuator unit piston to the extended position for 69-600-3, retracted position for 69-600-2 (refer to table 3-2).

(6) Adjust the hydraulic actuator governor linkage until it fits between the actuator unit piston clevis and the fuel injection pump shutoff lever.

**Table 3-2. HYDRAULIC ACTUATOR TEST VALUES**

<b>ACTUATOR STYLES</b>						
69-600-2						
13217E5390-2, 32D1560G13, 1261A05G02, 1289A86G02						
S3 SWITCH POSITION	COIL CURRENT		GAUGE PRESSURE			FLOW METER
	M2 (L1)	M3 (L2)	G 1	G 2	G 3	
<sup>1</sup> MECH BIAS	0	0	200 ± 20	150 ± 20	320 ± 20	GREEN AREA
<sup>2</sup> BAL COIL	.35 ± .02	.35 ± .02	200 ± 20	150 ± 20	320 ± 20	GREEN AREA
<sup>3</sup> RET PISTON	.70 ± .04	0	310 MIN	40 MAX	380 MAX	0
<sup>4</sup> EXT PISTON	0	.70 ± .04	40 MAX	310 MIN	380 MAX	0
<b>FULL FUEL POSITION – PISTON RETRACTED</b>						
<b>ACTUATOR STYLES</b>						
69-600-3						
13217E5390-3, 32D1560G31, 32D1560G32, 1261A05 G03, 1289A86G03						
S3 SWITCH POSITION	COIL CURRENT		GAUGE PRESSURE			FLOW METER
	M2 (L2)	M3 (L1)	G 1	G 2	G 3	
<sup>1</sup> MECH BIAS	0	0	150 ± 20	200 ± 20	320 ± 20	GREEN AREA
<sup>2</sup> BAL COIL	.35 ± .02	.35 ± .02	150 ± 20	200 ± 20	320 ± 20	GREEN AREA
<sup>3</sup> EXT PISTON	.70 ± .04	0	40 MAX	310 MIN	380 MAX	0
<sup>4</sup> RET PISTON	0	.70 ± .04	310 MIN	40 MAX	380 MAX	0
<b>FULL FUEL POSITION – PISTON EXTENDED</b>						



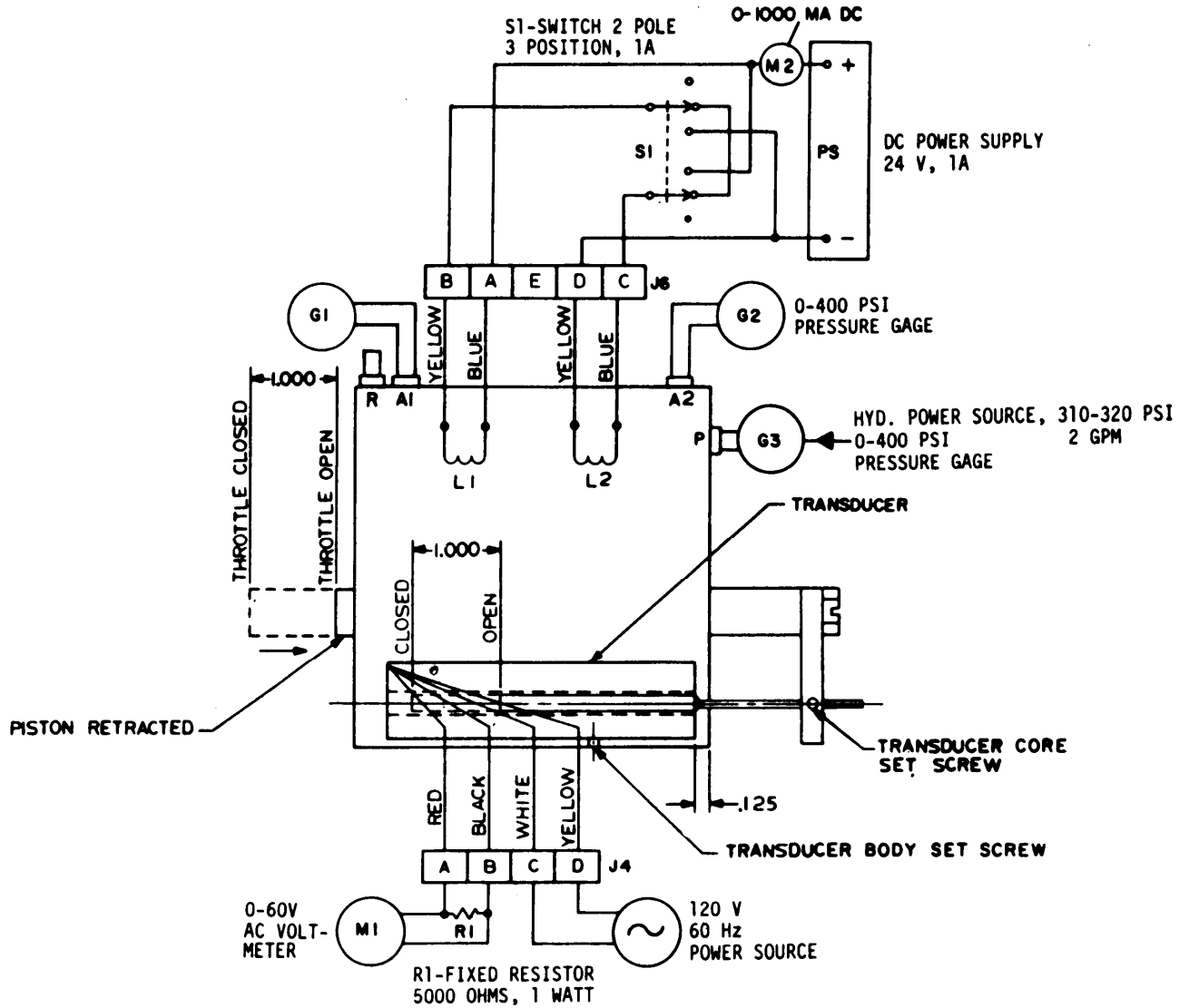

Figure 3-38.1 Hydraulic Actuator Tests, Schematic Diagram



(7) Return the generator set START-RUN-STOP switch to the STOP position and the BATTLE

SHORT switch to the OFF position.

## Section VI. INTAKE AND EXHAUST SYSTEMS AND BREATHER

### 3-43. GENERAL.

a. The intake system consists of a dry type air cleaner assembly with a reusable type filter element. The assembly removes dust and dirt from the engine combustion air. It is equipped with a restriction transducer. The restriction transducer measures vacuum in the air cleaner housing. When the filter element becomes sufficiently clogged that the vacuum begins to impair engine performance, the restriction transducer transmits an electrical impulse to the air cleaner condition indicator on the engine control panel.

b. The exhaust system consists of a muffler assembly. The system muffles the noise of engine operation and provides a means of expelling exhaust fumes from the generator set. The exhaust pipe end of the muffler assembly is fitted with a rain cap which prevents the entry of foreign material when the engine is and operating.

c. The breather system provides an escape for gases which accumulate in the engine crankcase during engine operation. The gases pass through the breather which traps oil vapors, and is drawn into the engine air cleaner housing through the heater tube.

### 3-44. AIR CLEANER ASSEMBLY.

Refer to the Operator and organizational Maintenance Manual for air cleaner assembly maintenance procedures.

### 3-45. EXHAUST PIPE AND MUFFLER.

Refer to the Operator and Organizational Maintenance Manual for exhaust pipe and muffler maintenance procedures.

### 3-46. BREATHER AND BREATHER TUBE.

Refer to the Operator and Organizational Maintenance Manual for breather and breather tube removal procedure.

## Section VII. ENGINE ASSEMBLY

### 3-47. GENERAL.

a. The engine assembly is a six cylinder, four cycle, fuel injected, compression ignition, liquid cooled diesel engine. The assembly consists of the cylinder head, rocker arm assembly, timing gears and housing, camshaft, flywheel and flywheel hawing, main bearings and crankshaft, piston and connecting rod assembly, and cylinder block.

b. The cylinder head is a one piece casting and is detachable. Valve seats are part of the casting, but valve guides are removable.

c. The rocker arm assembly is mounted on the cylinder head. It functions to open and close the valves.

d. The timing gears determine the sequence of valve opening and fuel injection. The gears are enclosed in a housing, the cover of which contains the front crankcase oil seal.

e. The cam shaft actuates the rocker arm assembly which operates the valves. It is driven by a gear which meshes with the crankshaft gear.

f. The flywheel is made of cast iron. It is machined to accommodate the coupling disc of the generator assembly. The flywheel is attached to the crankshaft by six bolts, one of which is off center. This permits the flywheel to be installed in only one position for timing purposes. The flywheel housing serves as a cover for the rear of the cylinder block and oil pan and as a partial enclosure for the flywheel. It provides the mounting for the starter assembly and also contains the rear crankshaft seal.

g. The crankshaft has seven main bearing journals and six connecting rod bearing journals. This arrangement places each connecting rod journal between two main bearing journals. All bearing journals are surface hardened and are drilled for oil passages.

h. The connecting rods are heavy alloy steel forgings with precision type bearings for the crankshaft and bronze bushings for the full floating piston pin. The pistons are made of aluminum and are the solid type (no saw slots or splits in the skirt). Each piston is fitted with five rings. The top three rings are compression type and the fourth ring from the top is an oil control ring. The fifth ring is an oil scraper ring.

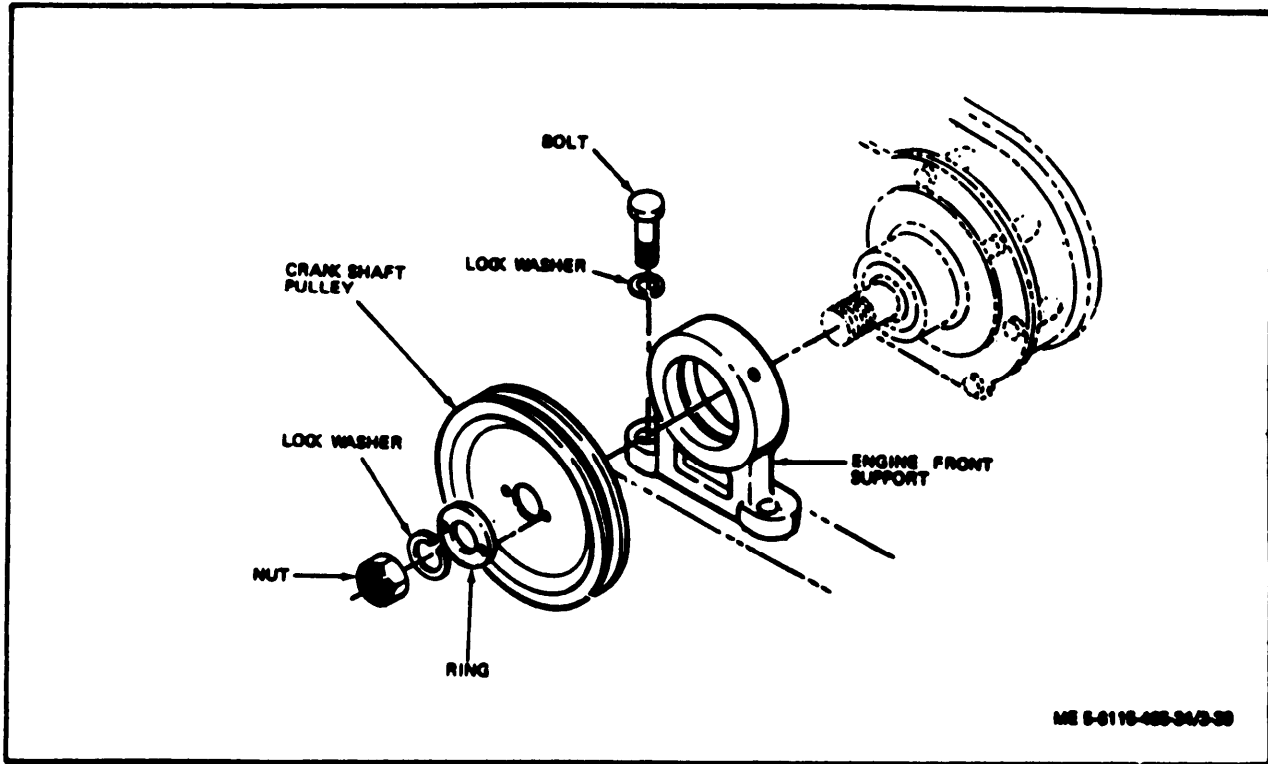

Figure 3-39. Engine Front Support, Removal and Installation.

i. The cylinder block and crankcase are cast as a single unit giving ridged support for the crankshaft. Cooling is obtained by water jacketing the entire length of the block. When installed in the generator set, the block is supported by the front engine support with rear support supplied through ridged coupling to the generator assembly housing.

3-48. ENGINE FRONT SUPPORT.

a. Removal.

NOTE

If engine is not removed from the generator set, block the front of the engine prior to removing the front engine support.

(1) Remove nut, lockwasher, ring, and pulley (figure 3-39).

(2) Remove front engine support from crankshaft by removing bolt and lockwasher.

b. Cleaning, Inspection, and Repair.

(1) Clean all parts in a dry cleaning solvent (Federal Specification P-D-680) and dry thoroughly with filtered compressed air. Remove caked grease deposits with a stiff bristle brush.

WARNING

Solvent, Dry Cleaning P-D-680, Type II is flammable and moderately toxic to skin, eyes and respiratory tract. Eye and skin protection required. Good general ventilation is normally adequate.

WARNING

Compressed air used for cleaning and drying purposes can create airborne particles that may enter the eyes. Pressure shall not exceed 30 psig and use only with adequate chip guards and chipping goggles.

(2) Inspect engine front support for cracks, corrosion, and excessive wear. Check inner surfaces for scores, ridging, and other damage.

(3) Check crankshaft pulley for corrosion, cracks, and step wear in v-belt groove.

(4) Check all threads for crossing, stripping, and peening.

(5) Repair minor thread damage with a thread chaser.

(6) Replace any parts damaged beyond repair.

c. Installation. Install engine front support in reverse order of removal procedure. Bolts for the front engine support should be torqued to 150 ft-lb dry, 110 ft-lb lubed.

3-49. FLYWHEEL AND FLYWHEEL HOUSING.

a. Removal.

(1) Remove oil pan assembly (paragraph 3-36).

(2) Remove screws (1, figure 3-40) to remove flywheel (2) and ring gear (3) as an assembly. Do not remove ring gear unless it is badly damaged and replacement is necessary.

(3) Remove nuts (4), lockwashers (5), screws

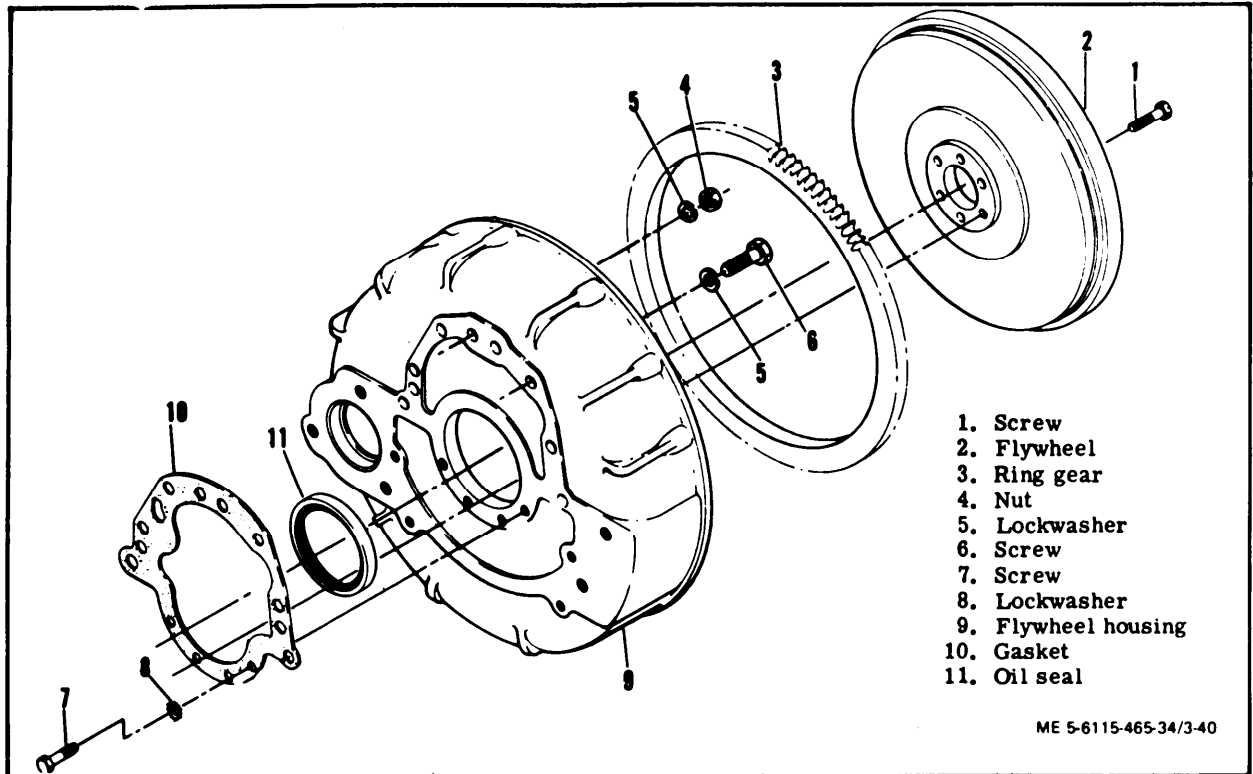

Figure 3-40. Flywheel and Flywheel Housing, Exploded View

(6), screws (7) and lockwashers (8) to remove flywheel housing (9) and gasket (10). Discard gasket.

(4) Using a suitable press, remove oil seal (11) from flywheel housing and discard.

b. Cleaning, Inspection, and Repair.

(1) Clean all parts in dry cleaning solvent (Federal specification P-D-680) and dry thoroughly. Remove caked grease deposits with a stiff bristle brush.

(2) Inspect flywheel for cracks, nicks, and burrs. Remove minor nicks and burrs with crocus cloth.

NOTE

Rinse flywheel in dry cleaning fluid after dressing with crocus cloth. Crocus cloth contains ferrous oxide which will accelerate rusting of cast iron parts.

(3) Inspect ring gear for cracks, chipped or broken teeth and other damage. If ring gear is badly damaged, replace as follows:

(a) Heat flywheel and ring gear in an oven at 450°F (232.2°C) for two hours.

WARNING

Wear asbestos gloves when handling heated flywheel to avoid serious burns.

(b) Remove flywheel and ring gear and lightly tap ring gear to separate.

(c) Heat replacement ring gear as in step (3)(a) above while freezing flywheel.

CAUTION

Wear asbestos gloves when handling frozen flywheel and heated ring gear.

(d) Quickly install heated ring gear onto frozen flywheel.

(4) Inspect flywheel housing for cracks, excessive corrosion, and defective paint.

(5) Repair cracks in flywheel housing by welding.

(6) Remove corrosion from flywheel housing with No. 00 grit abrasive paper soaked in oil. Clean flywheel housing with dry cleaning solvent after removing corrosion.

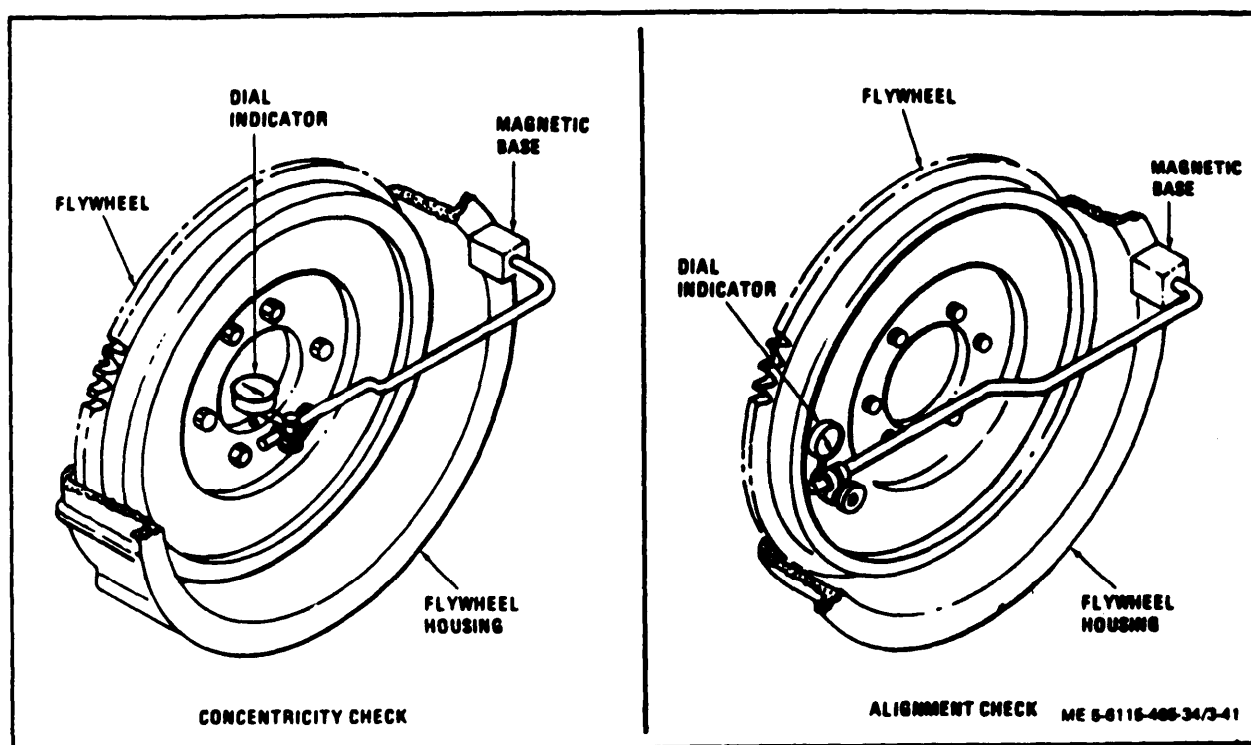

Figure 3-41. Checking Flywheel Concentricity and Alignment

(7) Repair defective paint by removing. Treat and paint.

(8) Replace oil seal each time flywheel housing is removed.

c. Installation. Install flywheel and flywheel housing in reverse order of removal procedures. Bolts for flywheel housing should be torqued to 75 ft-lb dry, 55 ft-lb lubed.

**NOTE**

One flywheel bolt is off center to insure proper alignment.

d. Testing.

(1) Turn crankshaft to dead center (DC) position.

(2) Attach a dial indicator to flywheel housing and position so that foot rides on inner face of pilot bore (see figure 3-41).

(3) Set dial indicator pointer to zero position.

(4) Slowly rotate crankshaft one complete revolution.

(5) Concentricity of pilot bore shall not vary 0.005 inch total reading.

(6) Position dial indicator so that foot rides on outer face of flywheel (see figure 3-41).

(7) Set dial indicator pointer to the "zero" position.

(8) Slowly rotate crankshaft one complete revolution.

(9) Alignment of flywheel shall not vary more than 0.005 inch total reading.

(10) Replace flywheel if the above test requirements cannot be met.

**3-50. TIMING GEARS AND COVER.**

a. Removal and Disassembly.

(1) Remove the hydraulic pump assembly (paragraph 3-40).

(2) Remove the fuel injector nozzle from No. 1 cylinder.

(3) Turn the engine over until the 20 degree before top dead center (BDC) mark on the engine flywheel is aligned with the timing mark on the flywheel housing and No. 1 cylinder is on compression stroke.

**NOTE:**

Spacers (35) located top  
and bottom holes of cover  
(17).

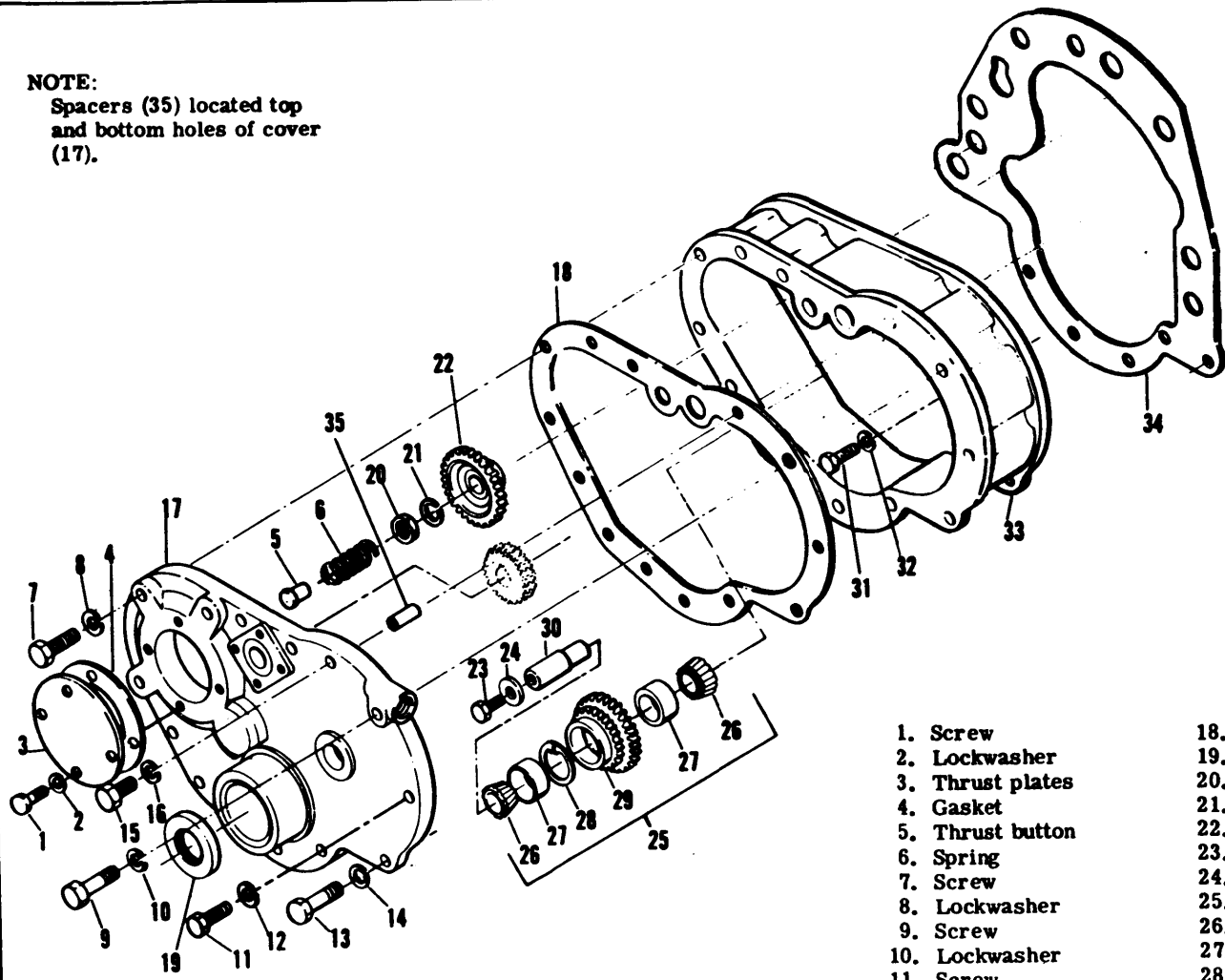

- |                       |                          |                |
|-----------------------|--------------------------|----------------|
| 1. Screw              | 18. Gasket               | 35. Spacer (2) |
| 2. Lockwasher         | 19. Seal                 |                |
| 3. Thrust plates      | 20. Nut                  |                |
| 4. Gasket             | 21. Lockwasher           |                |
| 5. Thrust button      | 22. Fuel pump drive gear |                |
| 6. Spring             | 23. Screw                |                |
| 7. Screw              | 24. Washer               |                |
| 8. Lockwasher         | 25. Idler assembly       |                |
| 9. Screw              | 26. Bearing              |                |
| 10. Lockwasher        | 27. Race                 |                |
| 11. Screw             | 28. Ring                 |                |
| 12. Lockwasher        | 29. Gear                 |                |
| 13. Screw             | 30. Idler shaft          |                |
| 14. Lockwasher        | 31. Screw                |                |
| 15. Screw             | 32. Lockwasher           |                |
| 16. Lockwasher        | 33. Housing              |                |
| 17. Timing gear cover | 34. Gasket               |                |

ME 5 6115-465-34/3-42

TN 5-6115-465-34  
TO 35C2-3-446-2  
NAVFAC P-8-625-34  
TM 06858B/06859D-34

Figure 3-42. Timing Gears and Cover, Exploded View

(4) Remove the front engine support (paragraph 3-48).

(5) Remove screws (1, figure 3-42) and lockwashers (2) to remove fuel pump thrust plate (3), gasket (4), thrust button (5) and spring (6). Discard gasket.

(6) Remove screws (7, 9, 11, and 13), screws (15), and lockwashers (8, 10, 12, 14, and 16) to remove timing gear cover (17) and gasket (18). Discard gasket.

(7) Press seal (19) from cover and discard.

(8) Remove nut (20) and lockwasher (21) to remove fuel pump drive gear (22).

(9) Remove screw (23) and washer (34) to remove idler assembly (25).

(10) If inspection indicates that idler bearings must be replaced, disassemble idler as follows:

(a) Remove bearings (26) and press races (27) from gear (29).

NOTE

Each bearing and race is a matched set and must be replaced as such.

(b) Remove ring (28) from gear.

(11) Do not remove idler shaft (30) from cylinder block unless inspection reveals damage.

(12) Remove screws (31) and lockwashers (32) to remove housing (33) and gasket (34). Discard gasket.

b. Cleaning, Inspection, and Repair.

(1) Clean all parts with dry cleaning solvent (Federal Specification P-D-680) and dry thoroughly.

(2) Visually inspect timing gear cover for cracks, corrosion, and other damage.

(3) Inspect gears for cracked, chipped or broken teeth and excessive wear.

(4) Inspect bearings for pitting and excessive wear.

(5) Inspect thrust plate for cracks and deep wear patterns.

(6) Inspect idler shaft for cracks, wear, and other damage.

(7) Inspect threads for crossing, stripping, and peening.

(8) Replace seal at each overhaul.

(9) Replace any damaged or worn parts.

c. Assembly and Installation

(1) Using new gasket, install housing (33) and secure with lockwashers (32) and screws (31).

(2) If shaft (30) was removed, press replacement into timing gear housing.

(3) If bearings were replaced, assemble idler assembly as follows:

(a) Install ring (28) into gear (29).

(b) Press races (27) into gear until they seat against ring.

(c) Install bearings (26).

(4) Check that 20 degree (BDC) mark on flywheel is still aligned with timing mark on flywheel housing.

(5) Install idler assembly and secure with washer (24) and screw (23). Torque idler shaft screw to 24-27 ft-lb.

(6) Install fuel pump drive gear (22) insuring that the proper timing has been maintained (see paragraph 3-20). Secure gear with lockwasher (21) and nut (20). Torque drive gear nut to 35-40 ft - lb.

(7) Press replacement seal (19, figure 3-42) into cover.

(8) Install gasket (18) and cover (17) and secure with lockwashers (8, 10, 12, 14, and 16), screw (15) and screws (7, 9, 11, and 13).

(9) Install spring (6), thrust button (5), gasket (4), and thrust plate (3) and secure with lockwashers (2) and screws (1).

(10) Install hydraulic pump assembly (paragraph 3-40).

(11) Install front engine support (paragraph 3-39).

(12) Install injector in No. 1 cylinder and tighten sufficiently to stop all leakage.

3-51. INTAKE MANIFOLD

Refer to the Operator and Organizational Maintenance Manual for intake manifold maintenance procedure,

3-52. EXHAUST MANIFOLD

Refer to the Operator and Organizational Maintenance Manual for exhaust manifold maintenance procedure.



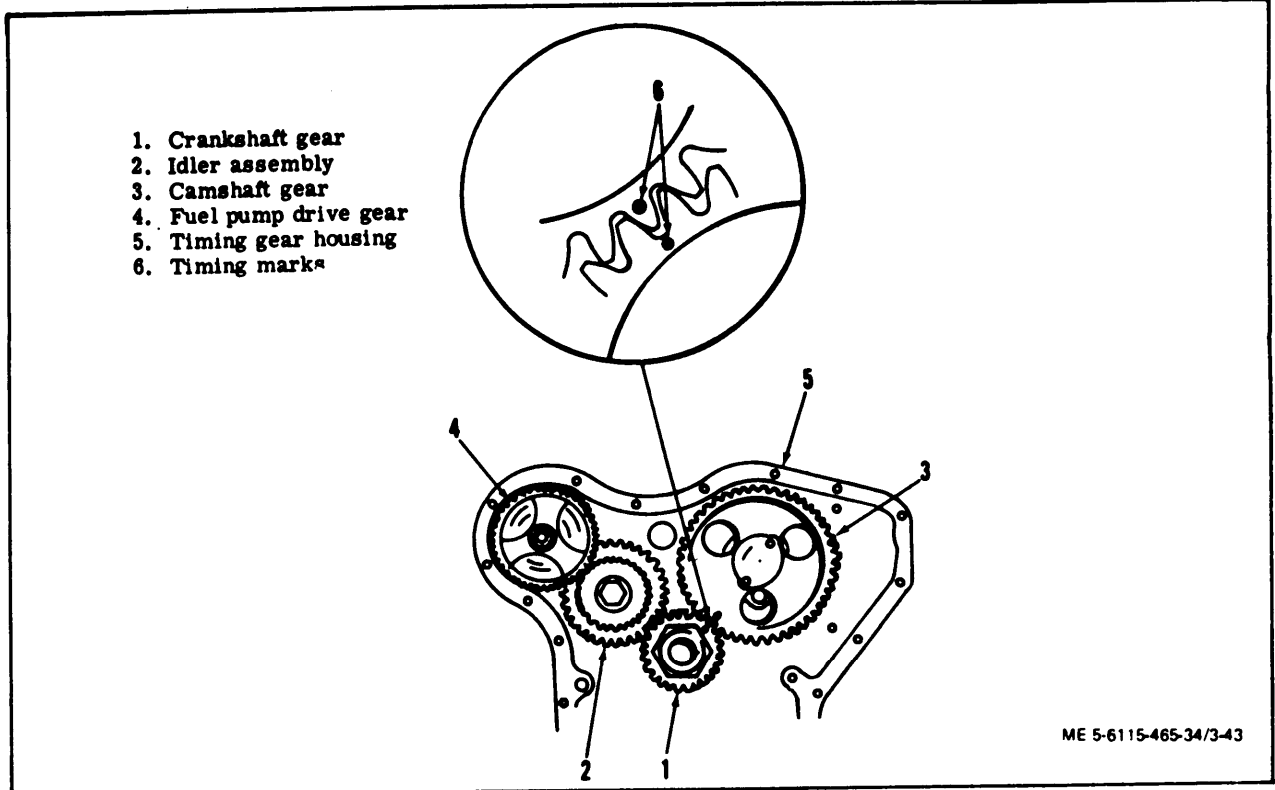

Figure 3-43. Timing Gear Relationships

3-53. CYLINDER HEAD AND ROCKER ARM ASSEMBLY.

a. Removal.

(1) Refer to the Operator and Organizational Maintenance Manual and remove the air cleaner assembly, muffler and exhaust pipe assembly, intake manifold, exhaust manifold, coolant control thermostat, and injector nozzle holder assemblies.

(2) Remove nuts (1, figure 3-44) and lock-washers (2) to remove lifting eyes (3).

(3) Remove nuts (4) and washers (5) to remove rocker arm assembly (6) and push rods (7).

(4) Remove nuts (8) and washers (9).

CAUTION

Tap cylinder head lightly with a soft hammer to loosen it. Do not pry on contact surfaces.

(5) Lift cylinder head (10) from engine.

(6) Remove and discard gasket (11).

b. Disassembly.

(1) Remove retaining rings (12) to remove mounting blocks (13, 13A, and 13 B), spacers (14), rocker arm (15) and springs (16) from shaft (18).

NOTE

Record position and quantity of spacers (14) to facilitate assembly.

(2) Remove adjustment screws (17).

(3) Separate shafts (18) and bushings (19) from center mounting block (20).

(4) Do not remove plugs (21).

(5) Using a valve spring depressor, depress valve springs and remove locks (22 and 23).

(6) Release valve springs and remove spring seats (24 and 25), valve springs (26 and 27), exhaust valves (28) and intake valves (29).

(7) Remove and discard bonnets (30).

(8) Do not remove valve guides (31 and 32), plugs (33), studs (34), fuel injector sleeves (36) and seal (35) unless inspection reveals damage.

(9) Remove side plates (19, figure 3-51) from cylinder block (22).

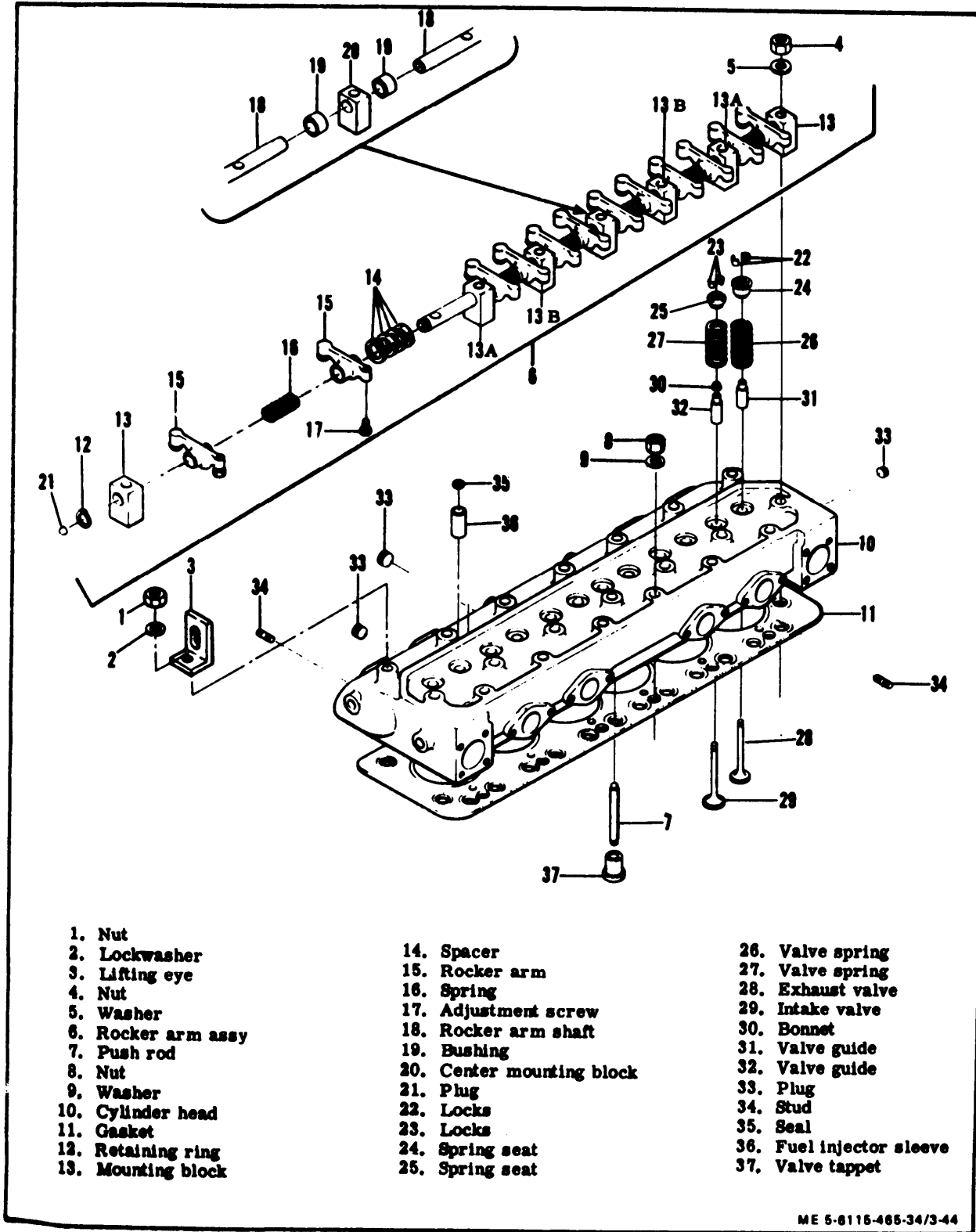

ME 5-8115-465-34/3-44

Figure 3-44. Cylinder Head and Rocker Arm Assembly, Exploded View

(10) Remove valve tappets (37).

*c. Cleaning, Inspection, and Repair.*

(1) Clean all parts in dry cleaning solvent (Federal Specification P-D-680) and dry thoroughly with filtered compressed air.

(2) Scrape carbon deposits from valves and cylinder head.

(3) Visually inspect rocker arms for cracks, corrosion, and excessive wear. Check that oil holes are open.

(4) Inspect rocker arm shafts for cracks, deep wear patterns, nicks, and burrs. Remove minor nicks and burrs with oil soaked crocus cloth. Clean polished shaft in dry cleaning solvent to remove abrasive particles.

(5) Inspect blocks for cracks, nicks, burrs, and excessive wear. Remove nicks and burrs from outer surfaces with fine abrasive paper or stone.

(6) Inspect springs for cracks, breaks, chaffing and distortion.

(7) Inspect push rods for cracks, bends, excessive wear, nicks and scratches. Polish push rods with crocus cloth to remove minor defects.

(8) Inspect valve guides for excessive wear. Bore diameter of exhaust valve guide shall be 0.3750 to 0.3790 inch. Bore diameter of intake valve guide shall be 0.3740 to 0.3780 inch.

(9) Replace worn valve guides as follows:

(a) Use a 5/8-inch drift with a 3/8-inch pilot and drive out valve guides.

(b) Drive replacement valve guides to a depth of 1.3700 to 1.3800 inches below cylinder head deck.

(c) Ream bore diameter of intake valve guides to 0.3740 to 0.3750 inch.

(d) Ream bore diameter of exhaust valve guides to 0.3750 to 0.3760 inch.

(10) Inspect valve springs for cracks, breaks, and distortion. Using a spring tester, compress valve spring to a length of 1.4920 inches. Test load shall be 72 to 82 pounds. Compress spring to a length of 1.0820 inches. Test load shall be 80 to 86 pounds.

(11) Inspect cylinder head for cracks, breaks, and broken studs. Remove broken studs by center punching, drilling, and using an easy out.

(12) Check cylinder head for warping using a straight edge and feeler gauge. Check lengthwise

and between each cylinder crosswise. Warp shall not exceed 0.003 inch laterally and 0.005 inch longitudinally. Cylinder head may be milled to remove minor warp.

(13) Perform magnetic particle inspection in accordance with established procedures.

(14) Inspect valve seats of cylinder head. If they are pitted or if new valve guides were installed, the valve seats must be refinished, using a tool with a 3/8-inch pilot. Both intake and exhaust valve seats should be refinished on an angle of 30 degrees for intake valves and 45 degrees for exhaust valves.

**NOTE**

Use a vibrating angle grinder type tool. The large diameter and surface area of the valve seats makes obtaining a proper finish with a reamer type tool extremely difficult.

(15) Inspect valves for bent or broken stems, cracks, and pitting of sealing surface. Using a micrometer, check valve stem diameter to determine wear. Stem diameter of intake valves shall be 0.3725 to 0.3735 inch. Stem diameter of exhaust valves shall be 0.3740 to 0.3750 inch.

(16) Check all threads for crossing, stripping, and peening. Repair minor thread damage with a thread chaser.

(17) Repair slightly damaged valves as follows:

(a) Polish stems with crocus cloth to remove minor nicks and scratches.

(b) Reface slightly pitted valves on a valve grinding machine. See table 1-1 for valve seat width.

(18) If valves and valve seats have been refinished or if contact surfaces are only slightly pitted, lap each valve into its seat as follows:

(a) Install a light coil spring with enough tension to hold valve off its seat.

(b) Lubricate valve stem and guide.

(c) Apply a thin coating of coarse grinding compound to the valve face.

(d) Insert valve into valve guide and attach a hand grinding tool.

**CAUTION**

Avoid continuous round and round motion which could cut grooves in valve face and seat.

(e) Rotate valve back and forth while applying firm pressure on the grinding tool.

(f) Release pressure on grinding tool, allowing coil spring to lift valve from its seat.

(g) Rotate valve 15° to 20° and repeat the grinding process.

(h) Periodically clean valve and seat to check progress.

(i) Replenish grinding compound and continue grinding until the valve seat and valve surfaces are in contact.

(j) Remove valve. Clean valve and valve seat to remove all traces of course grinding compound.

(k) Apply a thin coating of fine grinding compound to face of valve.

(l) Install valve into cylinder head and repeat grinding process until a bright, silver-like band of uniform width appears on both valve and seat.

(m) Removal valve. Clean valve and valve seat to remove all traces of grinding compound. Dry valve and valve seat thoroughly.

(n) Make ten or twelve pencil marks, equally spaced, across valve seat.

(o) Install valve, press firmly, and rotate approximately one quarter of a turn.

(p) Remove valve and observe pencil marks. If marks are rubbed out, valve is seating properly. If all pencil marks are not rubbed out, repeat grinding process.

### CAUTION

Mark each valve to insure that it will be installed in the seat into which it was ground.

(q) Repeat grinding process for each valve.

#### *d. Assembly.*

(1) Lubricate stem of intake valves (29) and exhaust valves (28) and insert into valve guides (31 and 32).

(2) Install bonnets (30), valve springs (26 and 27), spring seats (24 and 25) and locks (22 and 23).

### NOTE

Bonnets are installed on intake valves only.

(3) Assemble rocker arm assembly as follows:

(a) Install adjusting screws (17) into rocker arms (15).

(b) Assemble springs (16), rocker arms (15), spacers (14) and mounting blocks (13, 13A, 13B, and 20) onto rocker arm shaft (18). Make sure that mounting blocks and spacers are correctly installed (figure 3-45) and that oil holes in rocker arm shaft are correctly positioned (figure 3-46).

(c) Install retaining rings (12).

#### *e. Installation.*

(1) Install cylinder head and rocker arm assembly in reverse order of removal procedures.

(2) Tighten nuts to 75 lb-ft torque following the sequence of figure 3-47.

(3) Repeat the sequence, tightening each nut to 125 lb-ft torque.

(4) Again repeat the sequence, tightening each nut to a final torque of 160 ft.lbs. For 9/16 DIA. studs and 175 ft.-lbs. for 5/8 DIA. studs, as specified in Paragraph 1-6 v.

### NOTE

Nuts must be retorqued after 1 hour operation.

(5) Refer to the Operator's and Organizational Maintenance Manual and adjust the valve tappet clearance to a "HOT" setting of 0.015 inch.

### 3-54. Camshaft

#### *a. Removal.*

(1) Remove oil pan (para 3-86).

(2) Remove oil pump assembly (para 3-36).

(3) Remove timing gear cover (para 3-50).

(4) Remove rocker arm assembly and push rods (para 3-53).

(5) Rotate engine crankshaft until screws (1, fig. 348) are visible through holes in camshaft drive gear.

(6) Refer to the Operator's and Organizational Maintenance Manual and remove the fuel filter assemblies.

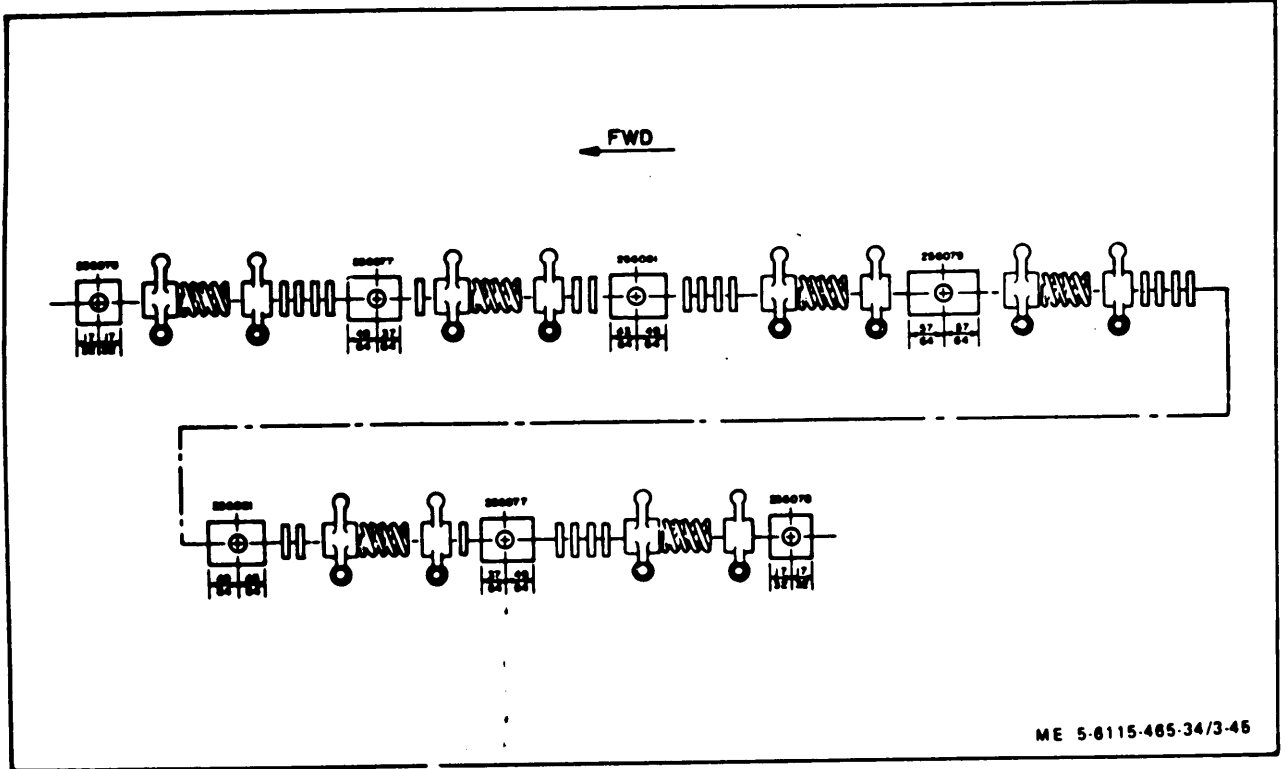

Figure 3-45. Rocker Arm Mounting Blocks Installation

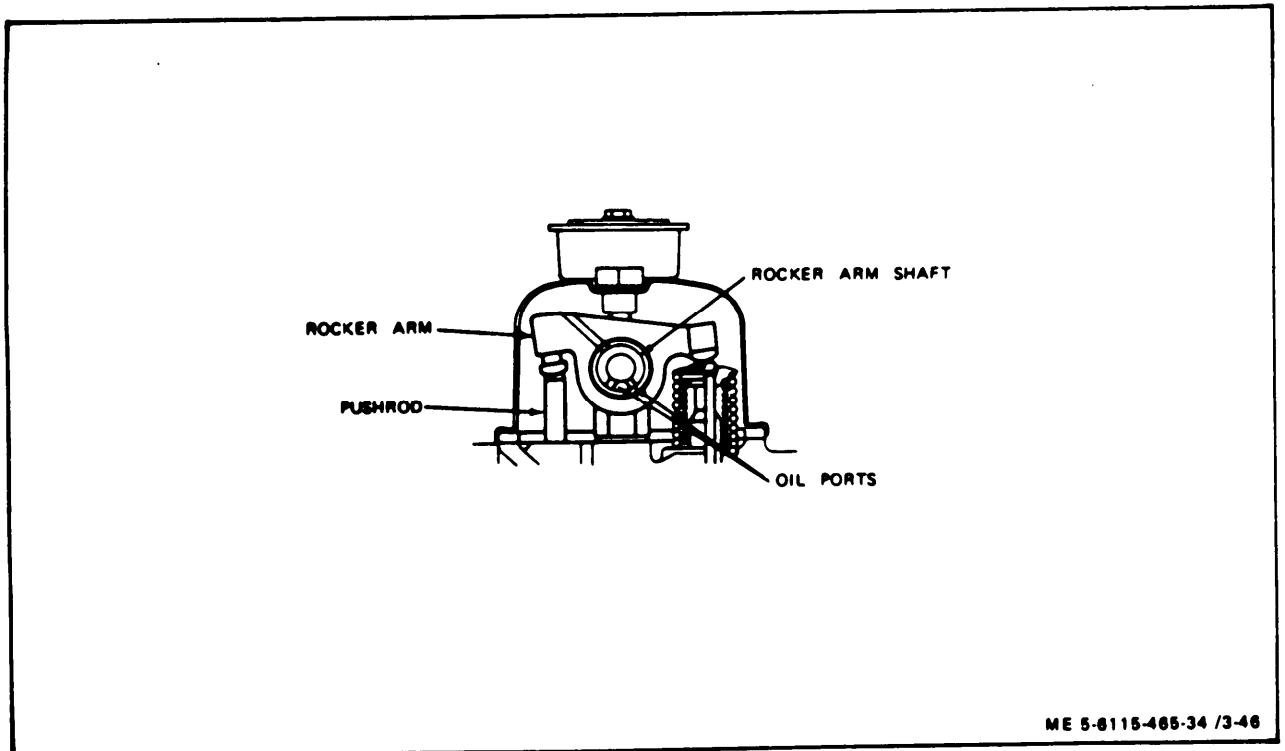

Figure 3-46. Rocker Arm Shaft Positioning

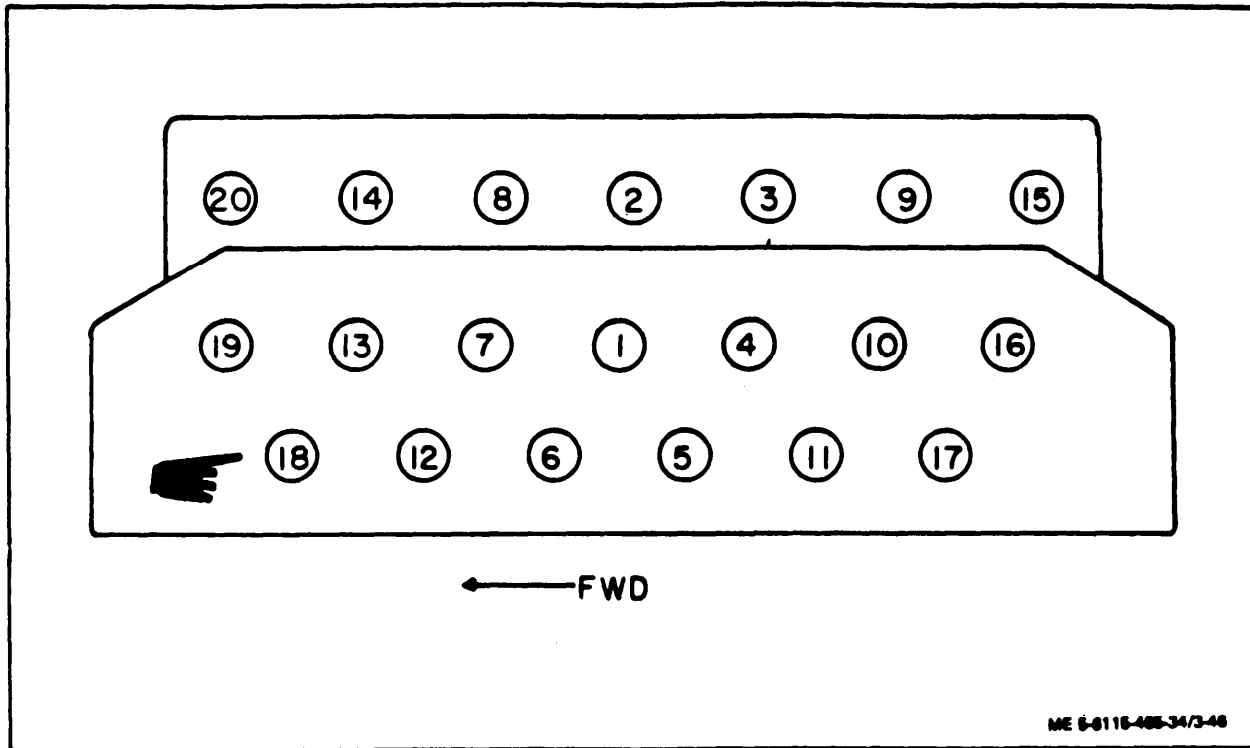

Figure 3-47. Cylinder Head Nut Tightening Sequence

NOTE

Rotate crankshaft as necessary to lift valve tappets. Use tapered wooden dowels or magnets to hold tappets in topmost position.

(7) Remove screws (1) and lockwashers (2) to remove camshaft.

(8) Remove valve tappets (35, figure 3-43).

b. Disassembly.

(1) Remove nut (3, figure 3-48) and support drive gear (4) on arbor press.

(2) Press shaft (5) out of gear and remove key (6) and thrust plate (7).

c. Cleaning, Inspection, and Repair.

(1) Clean all parts in dry cleaning solvent (Federal Specification P-D-680) and dry thoroughly with filtered compressed air.

(2) Visually inspect drive gear for cracks and chipped, broken, or worn teeth.

(3) Check thrust plate *for* cracks, breaks, and excessive wear.

(4) Using a micrometer, dimensionally inspect camshaft in accordance with figure 3-49.

(5) Inspect camshaft lobes and bearing journals for wear, scoring, and scratching. Polish minor nicks, scores, and scratches with crocus cloth. Clean to remove abrasive residue.

(6) Check camshaft bearing runout as follows:

(a) Place camshaft in a set of vee blocks.

(b) Position a dial indicator so that the foot rides on one of the bearing journals.

(c) Set indicator pointer to the "zero" positions.

(d) Slowly rotate camshaft one complete revolution while observing dial indicator.

(e) Runout shall not exceed 0.0040 inch total indicator reading.

(f) Repeat the check for each bearing journal.

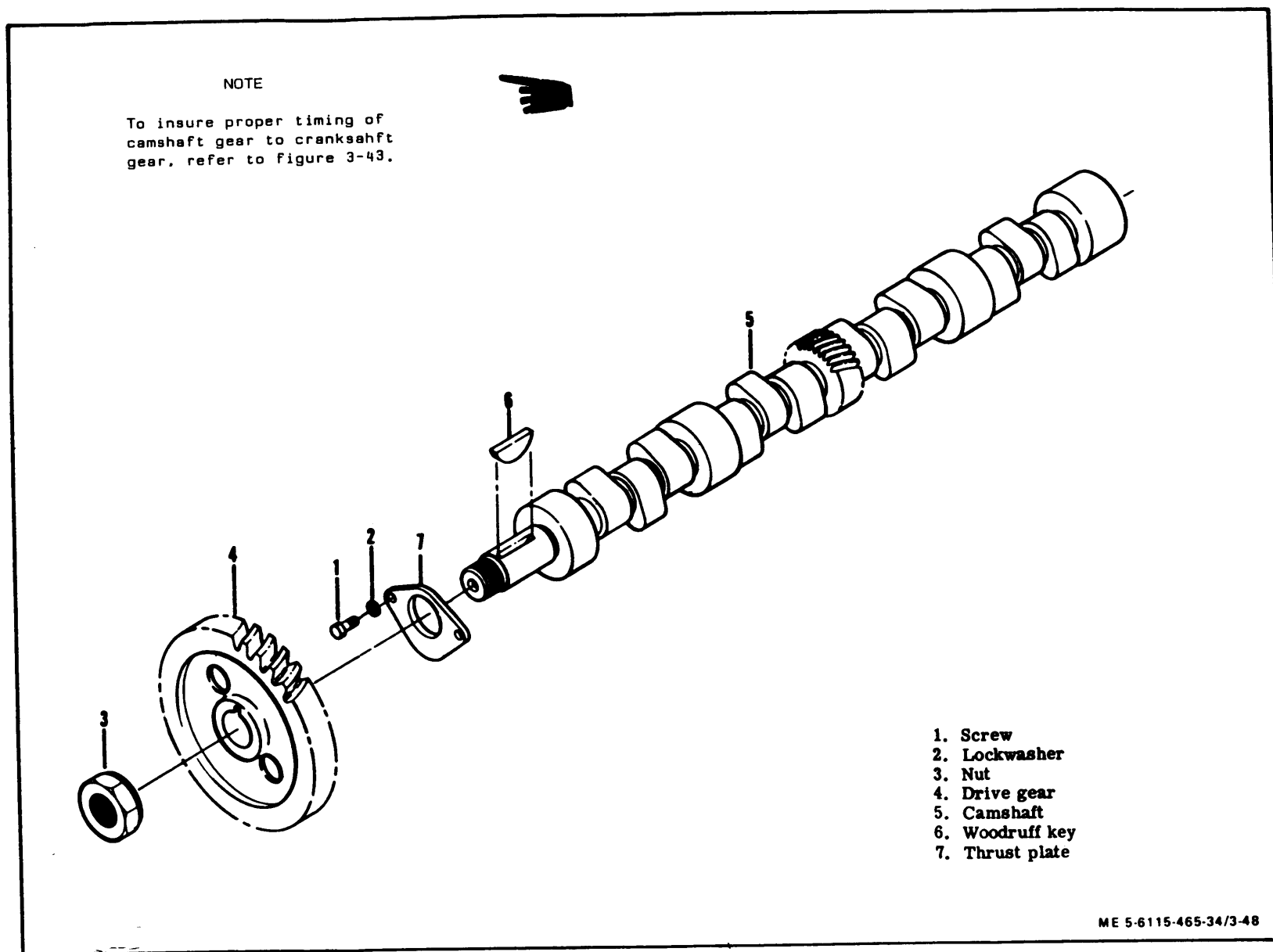

Figure 3-48. Camshaft, Exploded View

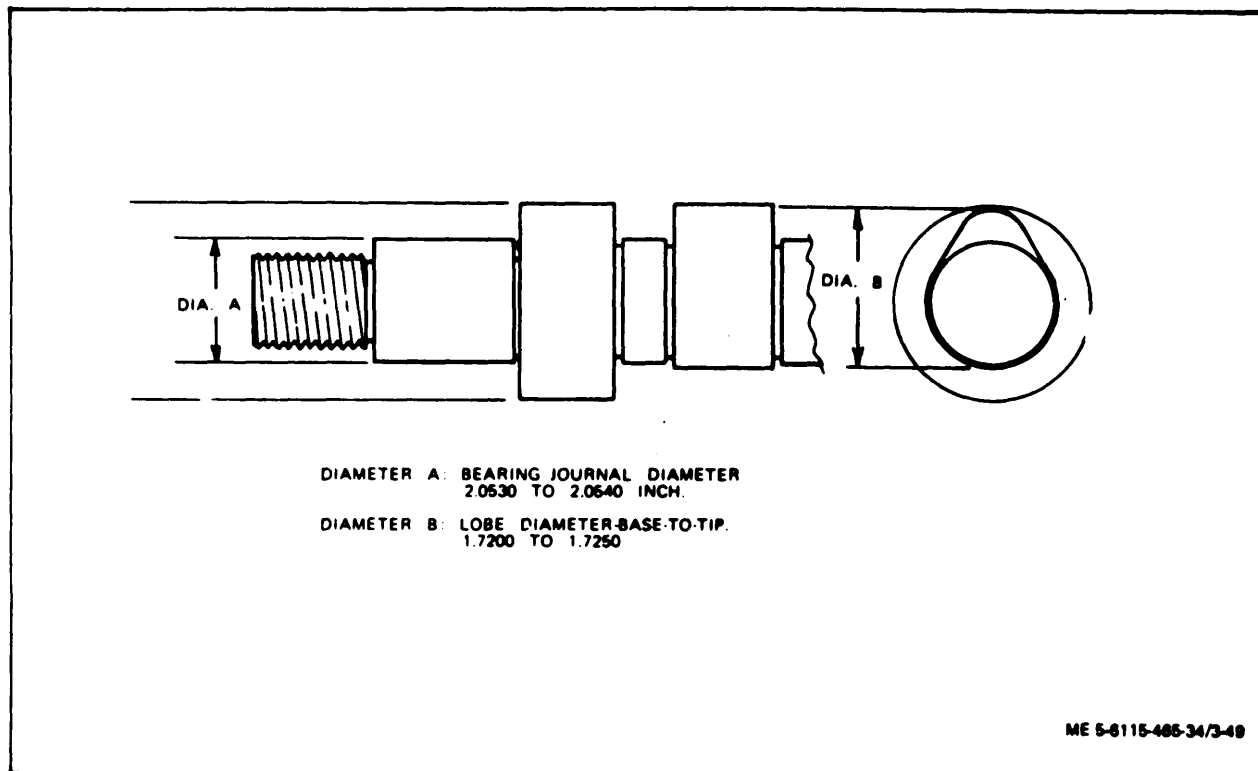

Figure 3-49. Dimensional Inspection of Camshaft

(7) If runout of any bearing exceeds limit specified total (step 6(e) above), replace camshaft and bearings.

(8) Perform magnetic particle inspection on camshaft and drive gear in accordance with established procedures.

(9) Check all threads for crossing, stripping, and peening. Repair minor thread damage using a thread *chaser*.

(10) *Measure and* record diameter of camshaft bearings in cylinder block. Subtract camshaft bearing journals dimensions from the corresponding bearing inner diameter. The difference shall not be less than 0.0015 inch or greater than 0.0035 inch.

(11) If dimension obtained in step (8) indicates excessive wear, replace camshaft bearings as follows:

(a) Using a suitable press, remove camshaft bearings from cylinder block.

**CAUTION**

Make sure that the replacement bearings are installed so that oil holes match with oil ports in cylinder block

(b) Press replacement bearings into cylinder block.

d. Assembly.

(1) Assemble camshaft in reverse order of removal procedures.

(2) Torque nut (3, figure 3-48) to 130 ft-lbs.

e. Installation.

**NOTE**

Valve tappets must be in the UP position to install camshaft.

**CAUTION**

Make sure that timing mark on camshaft drive gear mates with timing mark on crankshaft gear.

(1) Install camshaft in reverse order of removal procedures.

(2) Check camshaft end thrust as follows.



(a) Attach a dial indicator to the cylinder block and position so that the foot contacts the end of the camshaft

(b) *Press* camshaft as far into the cylinder block as it will go.

(c) Set dial indicator to "zero" position

(d) Move camshaft as far forward as it will go.

(e) Check indicator reading. Reading shall not exceed 0.0120.

(f) If reading exceeds specified limit, remove camshaft and replace thrust plate.

(3) Check backlash between camshaft drive gear and crankshaft gear. Backlash shall be 0.0010 to 0.0030. If backlash is not within specified limits, both camshaft drive gear and crankshaft gear must be replaced.

### 3-55. Crankshaft, Connecting Rods and Pistons

#### a. Removal.

(1) Remove oil pump assembly (para 3-37)

(2) Remove flywheel and flywheel housing (para 3-49).

(3) Remove cylinder head and rocker arm assembly (para 3-53).

(4) Using a ridge cutter, remove the ridge from the top of each cylinder.

(6) Remove screws (1, fig. 3-50) and connecting rod bearing caps (2) and lower half of connecting rod bearing insert (3).

(6) Using a wooden dowel, push pistons and connecting rods out top of cylinder block).

#### NOTE

Rotate crankshaft to simplify removal if necessary.

(7) Remove upper half of connecting rod bearing insert.

#### CAUTION

Keep connecting rod bearing caps with the connecting rod horn which they were removal

(8) Remove screws (4) and lockwashers (6) to

remove main bearing caps (6) and lower half of main bearing inserts (7).

(9) Remove screws (8) and lockwashers (9) to remove main bearing cap (10) and lower half of center main bearing insert (11).

(10) Lift crankshaft (12) from cylinder block and remove upper half of main bearing inserts

#### CAUTION

Conspicuously mark each main bearing cap as to position to aid at assembly.

#### b. Disassembly.

(1) Do not remove crankshaft gear (13) and woodruff key (14) unless inspection reveals damage and replacement is necessary.

(2) Remove retaining ring (15) and piston pin (16) to remove piston assembly (17) from connecting rod (18).

(3) Do not remove bushing (19) unless inspection reveals damage and replacement is necessary.

(4) Remove compression ring (21), scraper rings (22) and oil control ring (23) from piston (24). Discard piston rings.

#### c. Cleaning, Inspection, and Repair.

(1) Clean all parts in dry cleaning solvent (Federal Specification P-D-680) and dry with filtered compressed air.

(2) Clean all oil passages in crankshaft and connecting rods with a wire brush.

#### CAUTION

Use care to avoid damaging ring grooves in pistons

(3) Scrape carbon deposits from top and ring groove of piston.

(4) Inspect crankshaft for cracks, nicks and scratches on bearing journals or other damage. Remove minor nicks and scratches from bearing journals with crocus cloth. Clean to remove abrasive residue.

(5) Perform magnetic particle inspection of crankshaft in accordance with established procedures.

(6) Deleted.

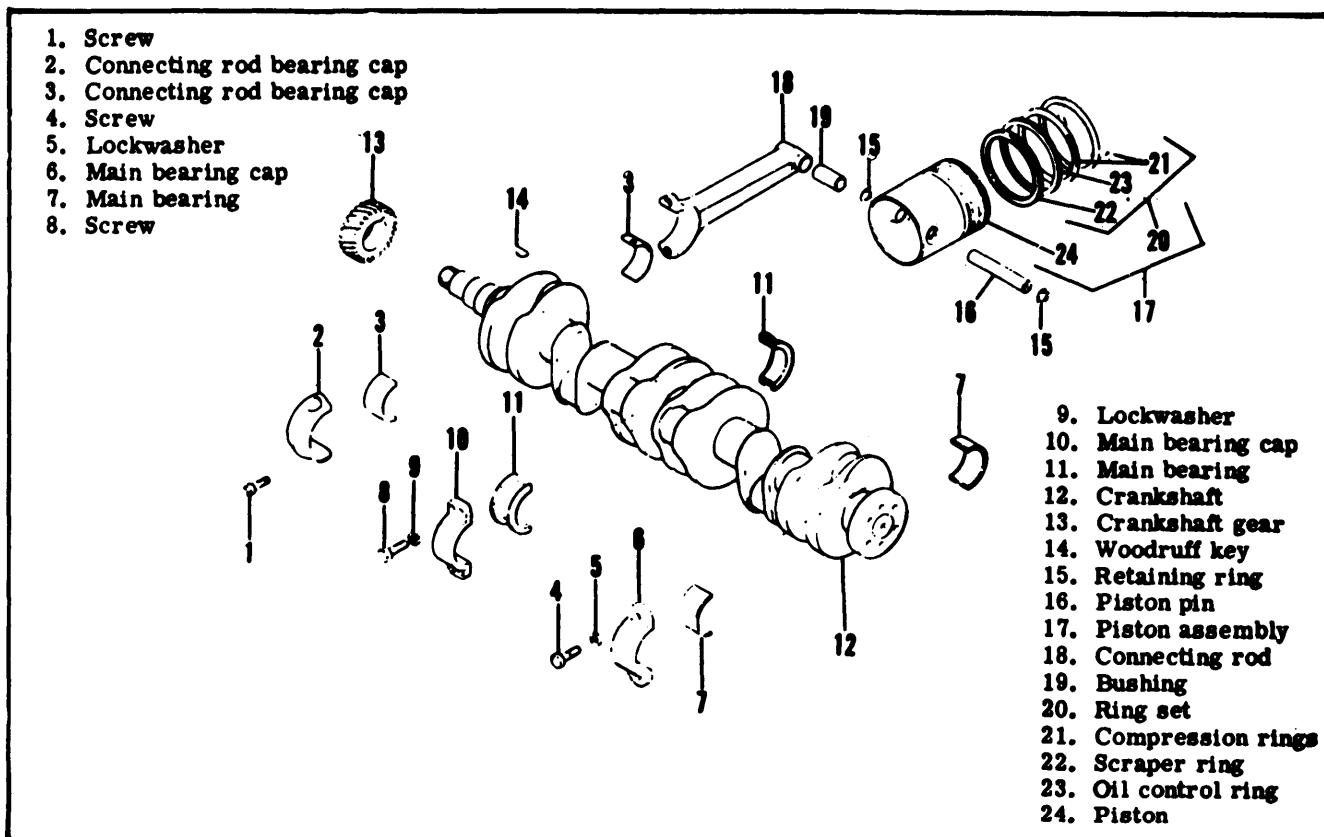

ME 5-6115-465-34/3-40

Figure 3-50. Crankshaft, connecting rods and pistons, exploded view.

**CAUTION**

When regrinding crankshaft it is imperative that the 6/32-inch radius from journal to cheek be maintained. Crankshaft breakage may result from improper grinding of this fillet

Table 3-3 Undersized Bearing Journals

Bearing size	Crankshaft journal diameter (IN.)	
	Main bearing	Connecting rod
Standard	2.8734/2.8744	2.8730/2.8740
0.020 inch	2.8534/2.8544	2.8530/2.8540
0.040 inch	2.8334/2.8344	2.8330/2.8340
0.060 inch	2.8134/2.8144	2.8130/2.8140

(7) If necessary, regrind crankshaft bearing journals to accept undersized bearings in accordance with table 3-3.

(8) Inspect crankshaft gear for cracks and chipped, broken or excessive worn teeth.

(9) If replacement of crankshaft gear is necessary, proceed as follows

(a) Support crankshaft gear in arbor press and press crankshaft and woodruff key from gear.

(b) Heat replacement gear in an oven at 450°F. (232.2°C) for approximately one hour.

(c) Install woodruff key into crankshaft

**CAUTION**

Wear asbestos gloves to avoid serious burns when handling heated gear.

(d) Remove gear from oven and assemble onto crankshaft. To insure proper timing of camshaft gear to crankshaft gear, refer to figure 3-43.

(e) Using a driver with an inside diameter of 2 inches, quickly drive gear into position.

(f) Allow crankshaft and gear to COOL

(10) Inspect connecting rod for cracks, breaks and excessively worn or damaged bushing.

(11) Check piston pin for nicks, burns, cracks, and excessive wear.

(12) Remove minor nicks and burrs from piston by polishing with crocus cloth. Clean to remove abrasive residue.

(13) If necessary, replace both piston pin and bushing.

NOTE

If new piston pin and bushing are used, check connecting rod alignment on a standard aligning fixture.

(14) Inspect piston for deep scores and scratches and other damage.

(15) Insert each piston into its cylinder bore with a piece of 1/2 x 0.0050 feeler ribbon. A force of 5 to 8 pads should be required to remove each ribbon. Replace all piston if any are not within the required limits.

NOTE

Cylinder bores may be rebored to accept oversized pistons (paragraph 3-56).

(16) Fit each piston ring into place into its cylinder bore and using a feeler gauge, measure gap dimension. Gap shall be 0.0100 to 0.0200 inch. If gap is under 0.0100 inch, file as follows:

(a) Hold a file in a vise.

(b) Grasp piston ring in both hands.

(c) Insert file into ring gap and move ring down the entire length of the file. Be sure to apply equal pressure on the ring.

(17) Roll each *ring* all the way around its piston groove to check clearance. If clearance is insufficient, lap the sides of the ring on a piece of No. 000 grit emery cloth laid on a flat surface.

d. Assembly.

(1) Using a piston ring expander install oil control ring (23, figure 9-50), scraper ring (22) and compression rings (21) onto pistons (24).

NOTE

If replacement piston rings have dots on the rim, the rings should be installed with the dots toward the piston head.

(2) Apply a light coat of engine oil to the bushing (19) and connecting rod (18) and press the bushing into the connecting rod.

(3) Fit piston assemblies (17) onto connecting rods (18) and insert piston pins (16). Install retaining rings (15).

e. Installation.

NOTE

Prior to installation of piston assemblies inspect cylinder block (paragraph 3-56), camshaft (paragraph 3-54) and cylinder head (paragraph 3-53) prior to installation of the piston, connecting rods and crankshaft.

(1) Install upper half of main bearings (7 and 11, figure 3-50) into cylinder block.

NOTE

Some of the bearings partially cover oil holes.

(2) Carefully place crankshaft (12) into position.

(3) Place a short strip of plastic gauge on each main bearing journal.

(4) Install lower half of main bearings, main bearing caps (6 and 10), lockwashers (5 and 9) and screws (4 and 8).

(5) *Tighten screws* (4) to 100 ft-lbs torque. Tighten screws (8) to 130 ft-lbs torque.

(6) Remove main bearing caps and lower half of main bearings. Check plastic gauge against standard to determine main bearing clearance. Clearance shall be 0.0009 to 0.0034 inch.

(7) If clearance is not within specified limits, grind crankshaft and install with undersized bearings (paragraph c(7) above).

(8) When bearing clearances have been established, install lower half of main bearings and main bearing caps (step (5) above).

NOTE

Apply a liberal coating of engine lubricating oil to inner surface of main bearings prior to installation.

(9) Use a feeler gauge to check crankshaft end thrust clearance on center main bearing. End thrust clearance shall be 0.0050 to 0.0100 inch.

(10) If end thrust clearance is not as specified, remove center main bearing end polish sides on a piece of crocus cloth. Clean to remove abrasive residue and apply a liberal coating of engine lubricating oil *before* installation.

(11) Apply a liberal coating of engine lubricating oil to cylinder bores, pistons, piston rings and piston pins.

NOTE

Proper position of the oil ring gap is with the gap aligned with either piston pin hole.

(12) Position piston rings so that no two gaps are aligned.

CAUTION

Use care to insure that connecting rod is properly aligned with crankshaft connecting rod bearing journal and that the pre-combustion chamber is away from the camshaft side of the engine.

(13) With piston rings compressed, use a hammer handle or wooden dowel to force piston down into cylinder bore.

(14) When entire piston is in cylinder bore, insert upper half of connecting rod bearing (3, figure 3-50) and pull connecting rod down to crankshaft.

(15) Place a short strip of plastic gauge on crankshaft and install lower half of connecting rod bearing, connecting rod bearing cap (2) and screws (1). Tighten screws to 70 lb-ft torque.

(16) Remove screws and connecting rod bearing cap to remove plastic gauge.

(17) Check plastic gauge against standard to determine bearing clearance. Clearance shall be 0.0010 to 0.0030 inch.

(18) When clearance is established, install lower bearing half, bearing cap and screws (step 16, above).

(19) Install timing gear housing and assembly.

(20) Install cylinder head and rocker arm assembly (paragraph 3-53).

(21 ) Install flywheel and flywheel housing (paragraph 3-49).

(22 ) Install oil pump assembly (paragraph 3-37).

3-56. CYLINDER BLOCK ASSEMBLY.

a. Removal and Disassembly.

(1) Remove engine assembly (paragraph 2-6).

(2) Remove timing gears and cover (paragraph 3-50).

(3) Remove flywheel and flywheel housing (paragraph 3-49).

(4) Remove cylinder head and rocker arm assembly (paragraph 3-53).

(5) Remove camshaft and bearings (paragraph 3-54).

(6) Remove timing gear and housing (paragraph 3-50).

(7) Remove crankshaft, connecting rods, and pistons (paragraph 3-55).

(8) Remove plugs (1 and 2, figure 3-51).

(9) Do not remove oil filler neck and captive cap assembly (3) or stud (4) unless inspection reveals damage.

(10) Do not remove studs (5 and 6) or guide pin (7) unless inspection reveals damage.

(11) Do not remove studs (8) and guide pin (9) unless inspection reveals damage.

(12) Do not remove studs (10, 11, 12 and 13) or guide pin (14) unless inspection reveals damage.

(13) Remove screws (15), flat washers (16), screws (17), lockwashers (18) to remove cover plate (19) and gasket (20) from cylinder block (22).

(14) Do not remove plug (21) from cylinder block (22) unless replacement is necessary.

b. Cleaning, Inspection, and Repair.

(1) Clean sludge and dirt deposits from cylinder block with dry cleaning solvent. If necessary, block should be steam cleaned.

(2) Clean all oil and water passages.

(3) Scrape carbon deposits from top of block.

(4) Remove gasket remains from all mating surfaces.

(5) Perform magnetic particle inspection of cylinder block in accordance with MIL-I-6868.

(6) Inspect cylinder bores for scores and scratches. Minor scratches and scores may be removed by honing. If necessary, cylinder bores may be rebored to accept up to 0.060 inch oversized pistons.

(7) Check cylinder bores for excessive wear. Diameter shall be 3.7490 to 3.7510 inches.

(8) Inspect cylinder bores for out-of-roundness. Each cylinder shall not be out-of-round by more than 0.0005 inch.

(9) Check cylinder bore taper. Taper shall be 0.0005 inch maximum.

(10) Non conformity to dimension specified in steps (7) through (9) above requires that cylinders be bored to accept oversized pistons.

(11) Temporarily install main bearing caps and check main bearing bore diameter. Diameter shall be 3.0665 to 3.0670 inches.

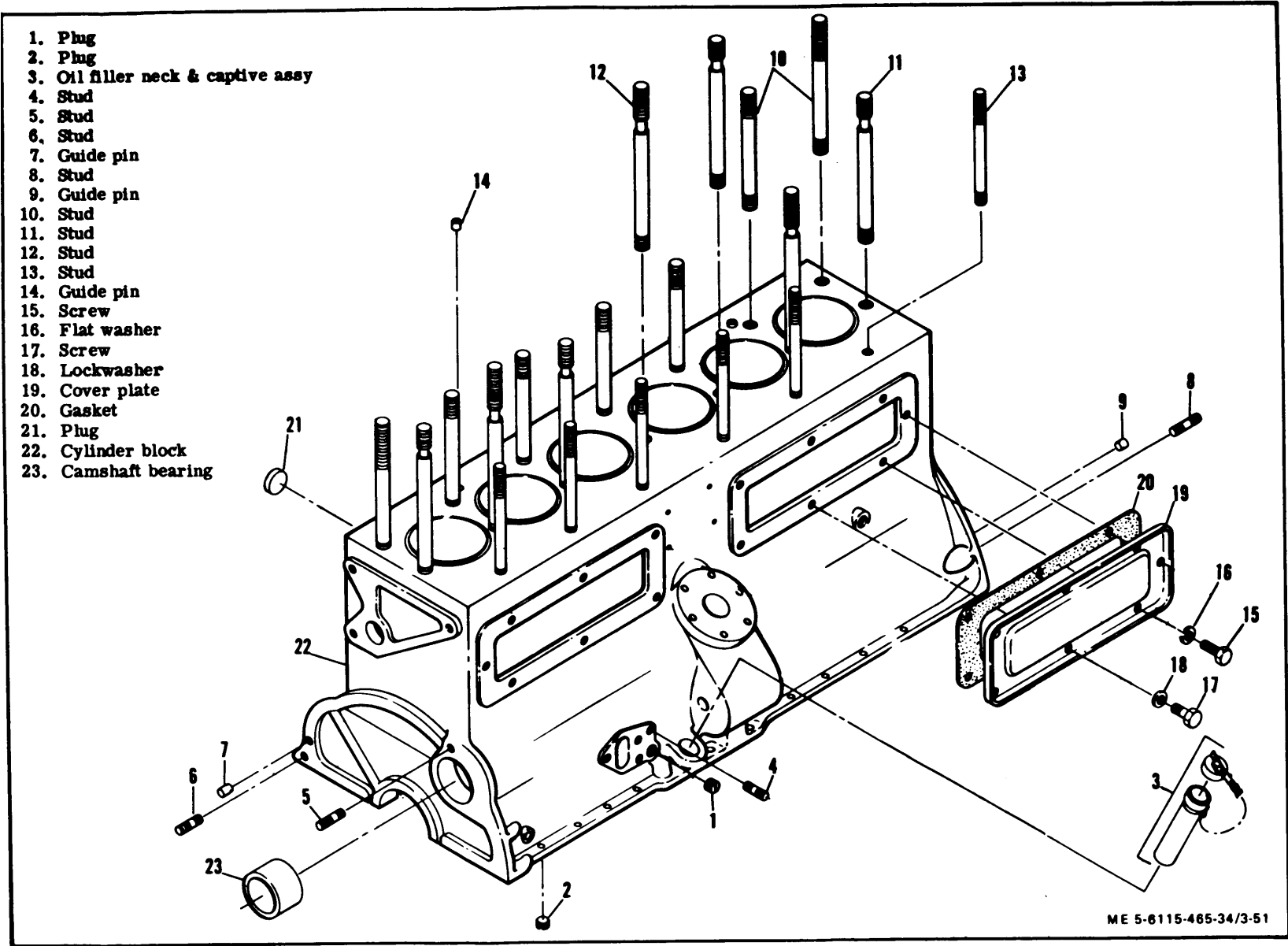

Figure 3-51. Cylinder Block Assembly, Exploded View

(12) Check camshaft bearing bore diameter. Diameter shall be 2.1870 to 2.1880 inches.

(13) Visually inspect main bearing and camshaft bearing bore diameters for nicks and scratches. Remove nicks and scratches with oil-soaked abrasive paper.

(14) Check oil pump bore diameter. Diameter shall be 2.0000 to 2.0005 inches.

(15) Inspect oil pump bore for nicks and scratches. Remove minor nicks and scratches by polishing with crocus cloth.

(16) Inspect for broken or damaged studs. If any studs are broken too short to allow removal, center punch, drill, and use an easy out.

(17) Inspect all gasket surfaces for nicks, burrs, and scratches. Remove nicks, burrs, and scratches with oil-soaked abrasive paper.

(18) Use a straight edge and check the block lengthwise, across each end and between cylinder bores for warping. Warp page shall not exceed 0.003 inch. Remove studs and guide pins and mill to a maximum of 0.005 inch top of block to correct a slight warpage. If cylinder block is warped sufficiently that milling would radically affect engine performance, replace block.

(19) Check all internal threads for crossing, stripping, and peening. Clean or repair minor thread damage. Repair extensively damaged threads by reaming, tapping and installing inserts.

c. Assembly and Installation.

(1) Assemble and install cylinder block in reverse order of removal and disassembly instructions.

(2) Prior to installation, mask all openings. Treat and paint.

CHAPTER 4

GENERATOR SET CONTROLS AND INTERCONNECTING WIRING HARNESS REPAIR INSTRUCTIONS

Section I. GENERATOR SET CONTROLS

4-1. GENERAL.

This section contains maintenance instructions for the generator set controls. The control cubicle assembly and sensing monitors contain the controls, instruments and indicators for controlling and monitoring the operation of the generator set. Precise models of the generator set incorporate a governor control unit which signals the actuator unit to change the fuel injection pump governor setting which controls engine speed and, thus generator frequency. This function is assumed by the manual speed control on utility models. The interconnecting wiring harnesses provide electrical connection between major assemblies and the control cubicle and fault locating indicator.

4-2. CONTROL CUBICLE ASSEMBLY.

a. Frequency Meter and Transducer.

(1) Refer to the Operator and Organizational Maintenance Manual and remove, clean, and inspect frequency meter and transducer.

(2) Install frequency meter and transducer in a test setup as shown in figure 4-1.

NOTE

Test frequency meter must have an accuracy of 0.05 percent.

(3) Activate sinusoidal source and adjust its output as indicated by the test frequency meter to the lowest frequency-indication on the frequency meter being tested (388 Hz for a 400 Hz frequency meter and 48 Hz for a 50/60 Hz frequency meter).

(4) Rotate adjusting screw of frequency meter being tested until its indication exactly matches that of the test frequency meter.

(5) If the frequency meter being tested cannot be properly adjusted, replace it and the frequency transducer.

(6) When frequency meter being tested has been properly adjusted, slowly increase the sinusoidal source-frequency to the highest value of the frequency meter being tested (412 Hz for a 400 Hz frequency meter and 62 Hz for a 50/60 Hz frequency meter).

(7) If at any point the indication of the

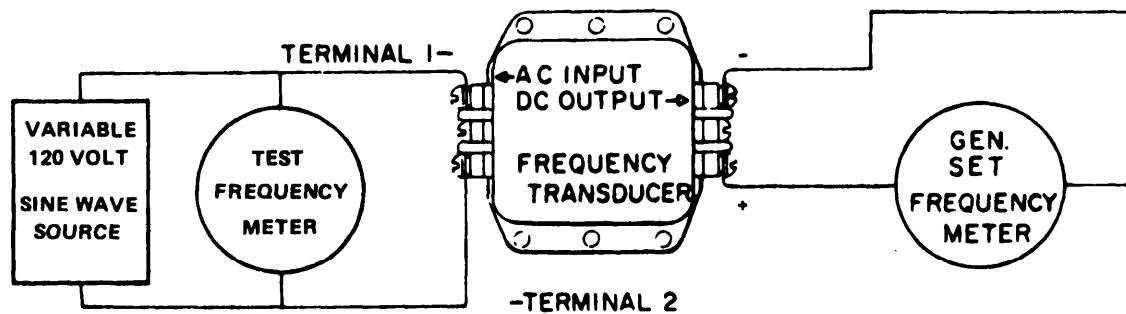

ME 5-6115-465-34/4-1

Figure 4-1. Frequency Meter And Transducer Test Setup

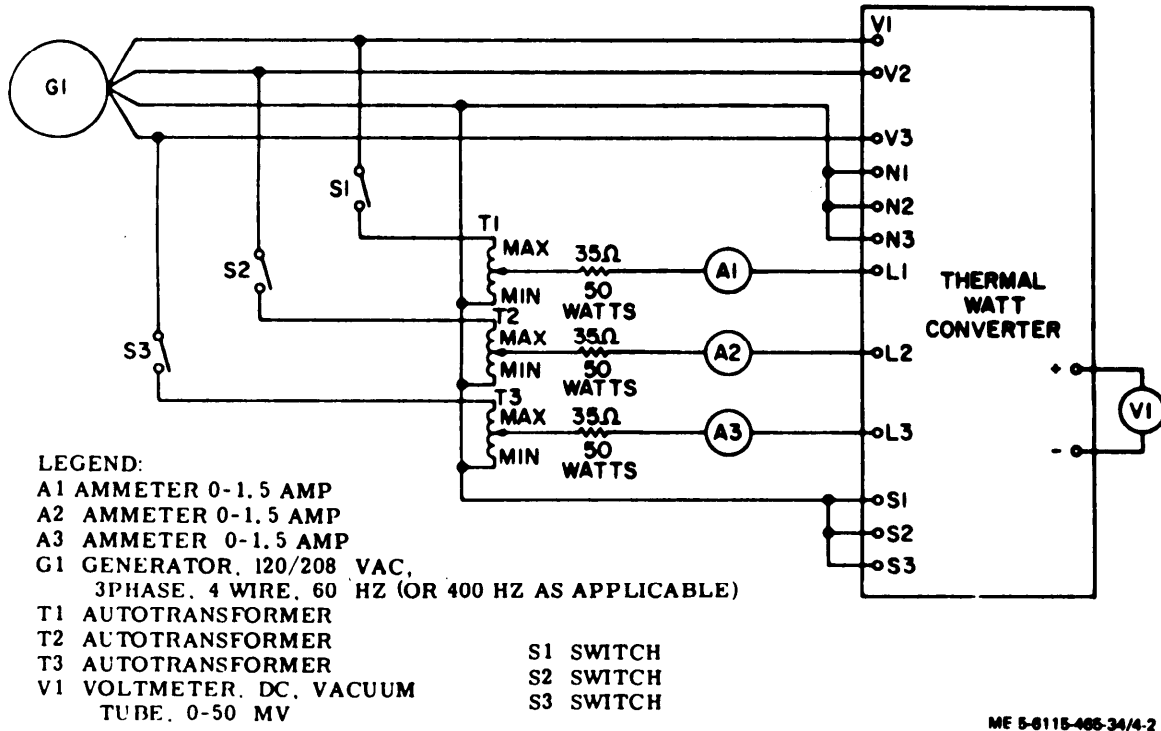

Figure 4-2. Thermal Watt Converter Test Circuit Schematic

frequency meter being tested varies more than 0.25 percent from that of the test frequency meter, replace both transducer and frequency meter being tested.

(8) Refer to the Operator and Organizational Maintenance Manual and install frequency meter and transducer.

b. Kilowatt Meter and Thermal Converter.

(1) Refer to the Operator and Organizational Maintenance Manual and remove, clean, and inspect kilowatt meter and thermal converter.

(2) Test ac kilowatt meter and converter as follows :

(a) Connect a calibrated kilowatt meter and a suitable variable load to the generator set load terminal board.

(b) Refer to the Operator and Organizational Maintenance Manual and start the generator set.

(c) Vary the load while comparing the generator set kilowatt meter reading to that of the calibrated kilowatt meter.

(d) If readings vary more than 1.33 percent, install thermal watt converter in a test set-up using figure 4-2 as a guide.

(e) Adjust all auto transformers to the minimum position.

(f) Close switch S1 and open switches S2 and S3.

(g) Energize power source G-1 and adjust auto transformer T1 until 1 ampere is indicated on ammeter A1.

(h) Check indication of voltmeter V1. Indication shall be  $6.66 \pm 0.04$  millivolts.

(i) Close switch S2 and adjust auto transformer T2 until 1 ampere is indicated on ammeter A2.

(j) Check indication of voltmeter. Indication shall be  $13.33 \pm 0.07$  millivolts.

(k) Close switch S3 and adjust auto transformer T3 until 1 ampere is indicated on ammeter A3.

(l) Again check voltmeter indication. Indication shall be  $20.00 \pm 0.1$  millivolts.

(m) Replace thermal watt converter if it fails to perform as indicated.

(n) If thermal watt converter performs as indicated, replace meter.



(o) Refer to the Operator and Organizational Maintenance Manual and install thermal watt converter.

c. AC Current Meter.

(1) Refer to the Operator and Organizational Maintenance Manual for AC current meter adjustment, removal, cleaning, inspection, and installation procedures.

(2) Test AC ammeter as follows:

(a) Connect a calibrated test ammeter in series with the generator set current meter.

(b) Connect a variable load to the generator set load terminal board.

(c) Refer to the Operator and Organizational Maintenance Manual and start the generator set.

(d) Vary the load while comparing the indication of the generator set current meter to that of the calibrated test ammeter.

(e) Replace generator set current meter if its indication varies more than 2 percent of full scale value from the indication of the test ammeter.

d. Control Cubicle Relay Assembly.

(1) Removal.

(a) Tag and disconnect electrical leads to relay assembly.

(b) Remove nut and captive washer assemblies (1, figure 4-3) to remove relay assembly (2).

(2) Disassembly.

(a) Identify any parts removed to facilitate assembly.

(b) Disassemble relay assembly only as is necessary to replace damaged or defective parts by following the ascending sequence of index numbers assigned to figure 4-4.

NOTE

Test relay assembly as outlined in subparagraph d. (5) below prior to disassembly.

(3) Cleaning, Inspection, and Repair.

(a) Clean relay assembly with filtered compressed air and a soft bristled brush.

(b) Visually inspect terminal boards for cracks, burns, and corroded or damaged terminals.

(c) Inspect relays (K1 and K6) for cracks, corrosion, and evidence of shorting.

(d) Inspect resistor (R10) for burns, damaged leads and insecure mounting.

(e) Inspect silicone rectifier (CR1) for cracks, burns, and evidence of shorting.

(f) Inspect printed circuit for cold solder joints, evidence of component over heating, and damage to the polyurethane coating.

NOTE

Prior to coating, deaerate resin by evacuating at room temperature to 5 to 10 Hg absolute to remove air bubbles.

(g) Check all components for illegible markings.

(h) If any circuit board component must be replaced or encapsulating coating repaired or replaced, refer to APPENDIX A references for detailed procedures. Repair/replace encapsulation by applying a 0.007 inch (minimum) coating of polyurethane resin (Scotchcoat 221, Minnesota Mining and Mfg. Co. or equal).

CAUTION

Solder joints and components leads shall not protrude more than 0.094 inch beyond surface of printed circuit board.

(i) Solder in accordance with requirement 5, MIL-STD-454.

(4) Assembly. Assemble relay assembly in reverse order of removal procedures.

(5) Testing.

(a) Using an ohmmeter or similar device, check relay assembly continuity using figure 4-5 as a guide.

CAUTION

Make sure that power supply leads are properly connected. Damage to the relay assembly will result if leads are connected to the wrong terminals.

(b) Connect a 120 Vat, 60 Hz power supply to terminals 4 and 12. Using a suitable voltmeter, measure voltage at terminals 6 and 10. Voltage shall be 120 Vat. If voltage is not as specified,

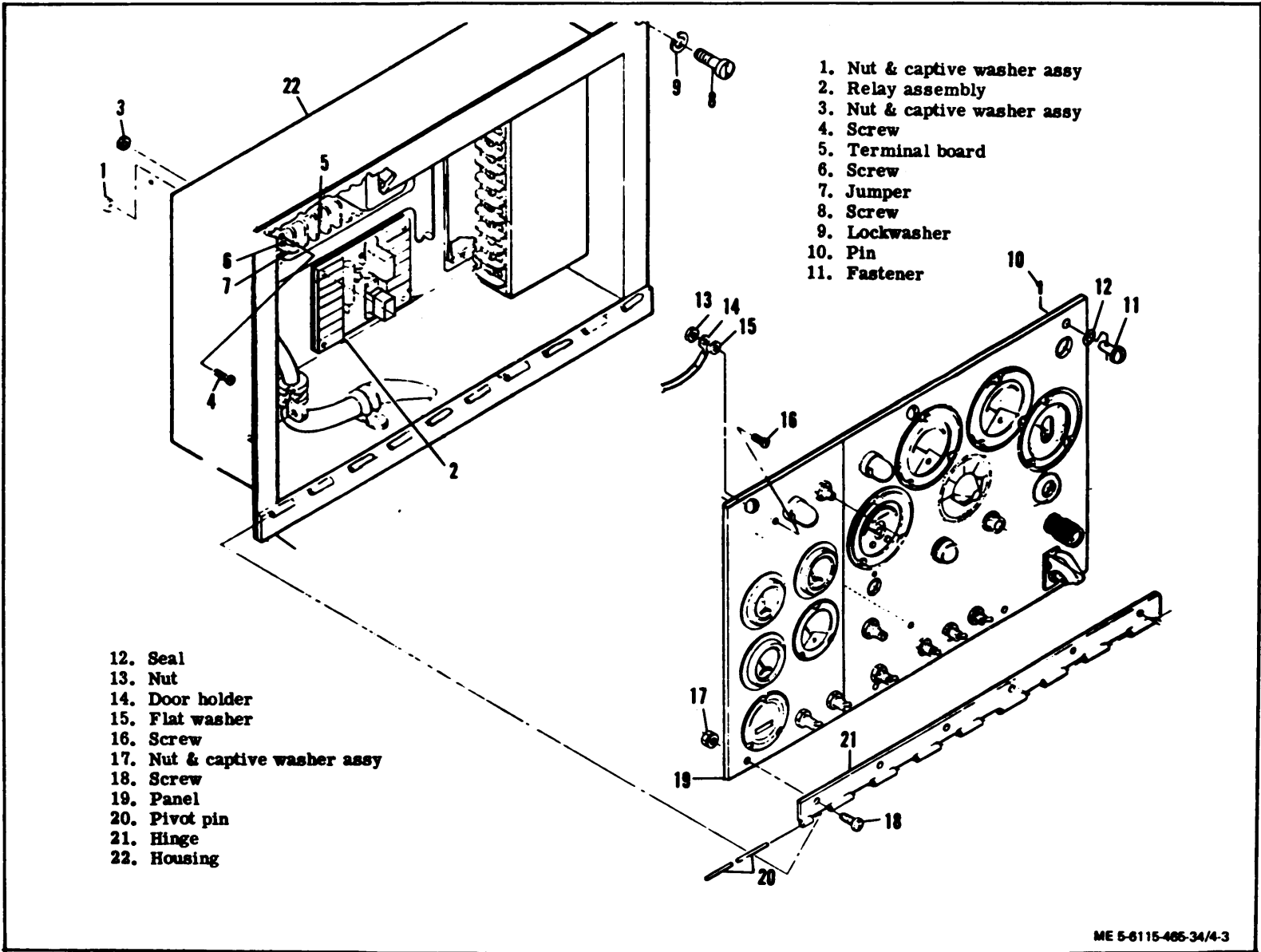

ME 5-6115-465-34/4-3

Figure 4-3. Control Cubicle Housing Assembly, Exploded View

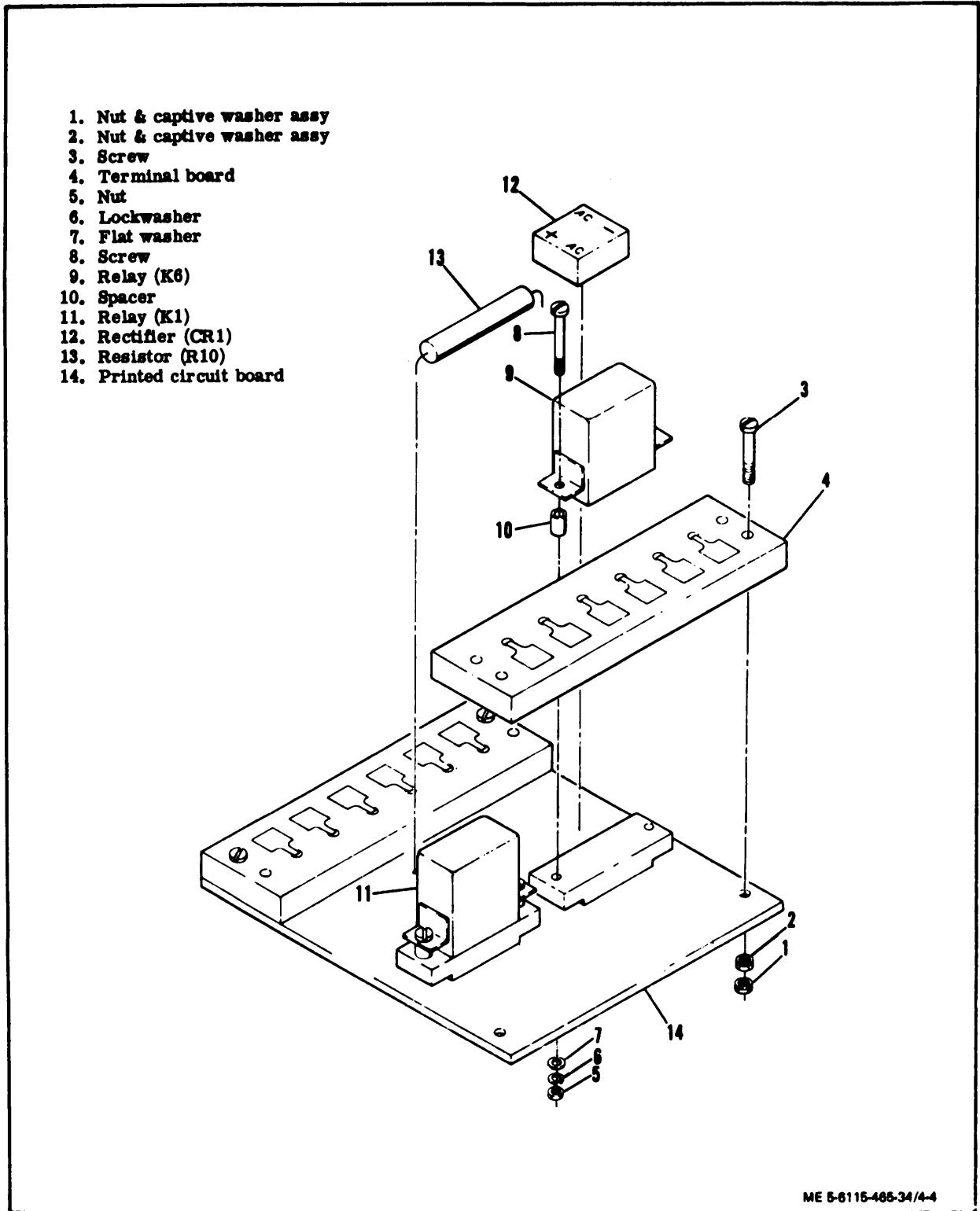

Figure 4-4. Control Cubicle Relay Assembly, Exploded View

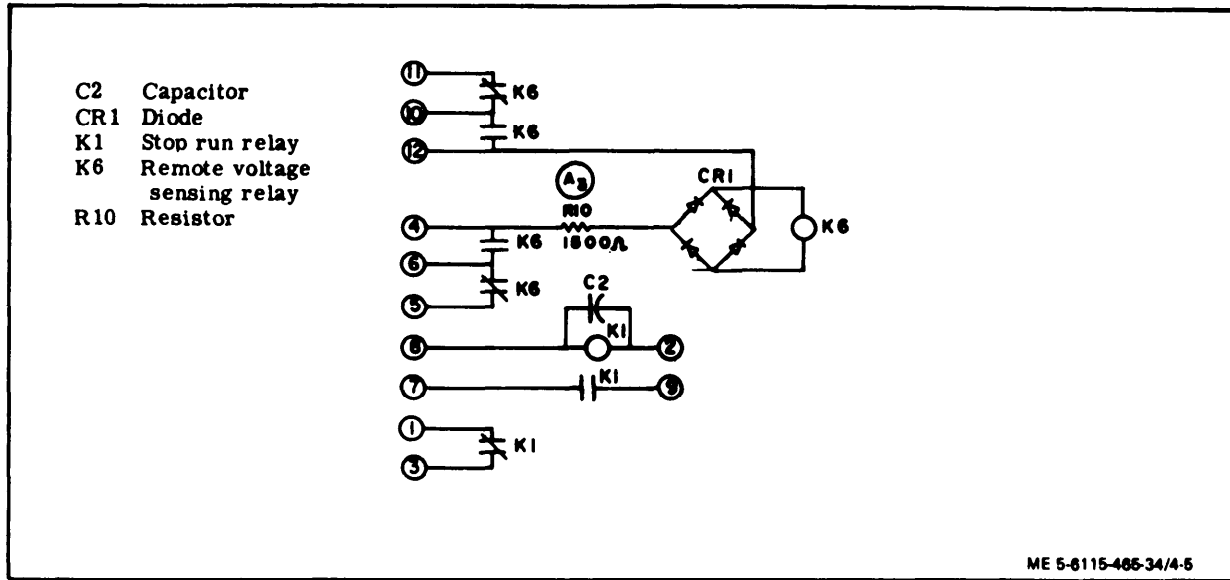

Figure 4-5. Control Cubicle Relay Assembly, Schematic Diagram

relay (K6) is defective. Check for open circuit across 10 and 5 and 6 and 11. There shall be no sign of continuity.

(c) If relay (K6) fails to function properly, proceed as follows:

1. Remove 120 Vac power.
2. Remove resin from back of relay (K6).
3. Apply 120 Vac power across terminals 4 and 12 and check voltage across relay (K6) coil. Voltage shall be 18 to 24 Vdc.
4. If voltage is not as specified, remove 120 Vac and check resistance across resistor (R10). Resistance shall be  $1500 \pm 10$  ohms. If resistance is not as specified, replace resistor.
5. If resistance is as specified, rectifier (CR1) is defective and must be replaced.

(d) Connect a 24 Vdc source across terminals 8 and 2 and check for continuity across terminals 7 and 9 and for open circuit across terminals 1 and 3. Replace relay (K1) if continuity is not as specified.

(6) Installation. Install control cubicle relay in reverse order of removal procedures.

e. Control Cubicle Terminal Board.

- (1) Removal.

(a) Tag and disconnect electrical leads to terminal board,

(b) Remove nut and captive washer assemblies (3, figure 4-3) and screw (4) to remove terminal board (5).

(c) Remove screws (6) and jumpers (7) only if inspection indicates replacement is necessary.

(2) Cleaning, Inspection, and Repair.

(a) Clean terminal board with a clean, lint-free cloth lightly moistened with an approved solvent.

(b) Visually inspect terminal board for cracks, lawns, and corrosion. Check insulating material for cracks, breaks, and other damage.

(c) Using an ohmmeter, check jumpers for continuity.

(d) Check all threads for crossing, stripping, and peening.

(e) Replace any damaged or defective parts.

(3) Installation. Install control cubicle terminal board in reverse order of removal procedures.

f. Control Cubicle Wiring Harness.

(1) Refer to the Operator and Organizational Maintenance Manual for wiring harness removal, cleaning, inspection, and repair procedures.

(2) If the wiring harness has sustained damage and requires repair, or rebuild, refer to figure 4-6 for layout, identification and material requirements and Appendix A for detailed soldering and replacement procedures.

(3) Refer to the Operator and Organizational Maintenance Manual for wiring harness installation procedures.

g. Control Cubicle Housing Assembly.

(1) Removal. Remove screws (8, figure 4-3) and lockwashers (9) to remove control cubicle housing assembly from generator set.

(2) Disassembly.

(a) Remove pin (10) to remove fastener (11) and seal (12).

(b) Remove nut (13), door holder (14), flat washer (15) and screw (16).

(c) Remove nut and captive washer assemblies (17) and screws (18) to remove panel (19).

(d) Remove pivot pin (20) and hinge (21) from housing (22) only if replacement is necessary.

(3) Cleaning, Inspection, and Repair.

(a) Clean all parts in dry cleaning solvent (Federal Specification P-D-680) and dry with filtered compressed air.

(b) Visually inspect housing for cracks, dents, and defective paint. Check hinge for cracks, excessive wear, and cracked or broken welds.

(c) Inspect panel for cracks, dents, warping, defective paint and illegible marking. Check fasteners for wear, damaged or deteriorated seals, and damaged pins.

(d) Check all threaded parts for crossed, stripped, and peened threads.

(e) Repair dents and warping by straightening.

(f) Remove defective paint and repaint.

(g) Replace any parts worn or damaged beyond repair.

(4) Assembly. Assemble control cubicle housing in reverse order of removal procedures.

(5) Installation. Install control cubicle housing in reverse order of removal procedures.

h. Refer to the Operator and Organizational Maintenance Manual for maintenance procedures of the remainder of the controls in the control cubicle assembly.

4-3. FAULT LOCATING INDICATOR.

a. Removal.

(1) Disconnect wiring harness from back of fault locating indicator.

(2) Remove screws (1, figure 4-7) and lockwashers (2) to remove fault locating indicator from generator set.

b. Disassembly.

(1) Remove screw and captive washer assemblies (3) and cover plate (4).

(2) Remove screw and captive washer assemblies (5) and carefully pull indicator panel assembly (6) away from housing. Tag and disconnect electrical leads.

(3) Disassemble panel assembly (items 7 through 24) only as is necessary for replacement of damaged or defective components.

(4) Remove screw and captive washer assemblies (25) to remove cover plate assembly (26). Tag and disconnect electrical leads.

(5) Disassemble cover plate assembly (items 27 through 32) only as is necessary for testing and replacement of components.

(6) Remove screw and captive washer assemblies (33) to remove wiring harness (34) from housing (35).

c. Cleaning, Inspection, and Repair.

(1) Clean all metallic, non-electrical parts with dry cleaning solvent (Federal Specification P-D-680) and dry with filtered compressed air.

(2) Clean electrical components with filtered -compressed air and a soft bristle brush. If necessary, electrical components may be cleaned with a clean, lint-free cloth moistened with an approved solvent.

(3) Visually inspect housing and cover plates for cracks, corrosion, warping, and other damage.

(4) Inspect panel assembly as follows:

(a) Check panel for cracks, corrosion, warping, illegible markings and other damage.

Figure 4-6. Control Cubicle Wiring Harness (Sheet 1 of 3) Drawing No. 69-677

WIRE BARRING NO	FROM		TO		WIRE FIND NO	CUT LENGTH IN	BARRING COLOR
	STATION NO	LUG FINE NO	STATION NO	LUG FINE NO			
C2C816	J1-A	-	A1-11	0	1	21.5	BLACK
D21816	J1-B	-	A1-12	0	1	22	
D22816	J1-C	-	A1-13	0	1	22.5	
C24816	W0-(-)	16	S0-01	0	1	6	
D24216	J1-B	-	W0-(-)	10	1	30	
D28816	A1-(-)	4	W7-(-)	7	2	52.5	
D2C816	A1-(-)	4	W7-(-)	7	2	52.5	
E28816	A1-52	0	S0-33	0	1	40.5	
G69816	A1-51	0	S0-32	0	1	34	
D70816	A1-53	0	S0-34	0	1	40.5	
C83816	S0-31	0	W0-(-)	10	1	7	
D84816	S0-11	4	W0-(-)	7	2	10	
D85816	S0-21	4	W0-(-)	7	2	11	
C86816	A2-(-)	4	W6-(-)	7	2	44.5	
D87816	A2-(-)	4	W6-(-)	7	2	47.5	
E35816	J1-1	-	W4-(-)	7	2	3	RED
E36816	J1-2	-	W4-(-)	7	2	33	
E37816	J1-1	-	W7-(-)	0	2	34	
E38816	J1-B	-	W2-(-)	0	2	30	
E39816	J1-A	-	W1-(-)	0	2	42	
K32816	J1-B	-	B1-B	5	2	29.5	BLACK
K33816	J1-B	-	B1-B	5	2	30	BLACK
K34816	J1-T	-	B1-L	5	2	31	BLACK
L23816	B51-2	4	S4-2	4	2	22.5	RED
L23816	B51-2	4	B52-2	4	2	10	RED
L23C16	B52-2	4	B52-2	4	2	17	RED
L25816	J1-7	-	S6-3	4	2	24.5	BLACK
L26216	J1-E	-	S6-6	4	2	23.5	BLACK
L24816	S7-12	4	B52-2	4	2	10	BLACK
L26216	S6-2	4	B54-2	4	2	10	BLACK
L26816	S6-5	4	B55-2	4	2	0	BLACK
L53816	J1-B	-	B55-2	4	2	32.5	BLACK
P40816	J1-A	-	T01-5	11	1	12	RED
P40P16	J1-A	-	T01-5	11	1	11	
P46816	T01-5	11	S2-11	0	1	42.5	
P4C516	S2-2	0	S2-11	0	1	7	
P4D716	S2-5	0	S2-2	0	1	6	
P4P116	S2-5	4	S4-1	4	2	14	
P4C116	S4-1	4	B56-3	1/4 STRIP	2	10	
P4C816	B57-3	1/4 STRIP	B56-3	1/4 STRIP	2	10.5	
P4D816	T04-5	11	B50-3	1/4 STRIP	2	52	

WIRE BARRING NO	FROM		TO		WIRE FIND NO	CUT LENGTH IN	BARRING COLOR
	STATION NO	LUG FINE NO	STATION NO	LUG FINE NO			
P43816	S7-5	0	S2-12	0	1	22	RED
P44816	S7-1	0	S7-4	0	1	23	
P44816	J1-A	-	S7-4	0	1	37	
P45816	T01-10	11	S2-3	0	1	45	
P45816	S2-3	0	S7-0	0	1	22	
P45C16	S7-0	0	S7-11	0	1	7	
P45D16	J1-B	-	T01-10	11	1	14.5	
P45E16	T01-10	11	A4-7	11	1	11	
P46816	J1-1	-	S1-2	0	1	34	
P47816	S2-6	0	S7-0	0	1	22.5	
P47816	J1-A	-	S7-0	0	1	30	
P50816	T01-0	11	A4-9	11	1	12	
P50G16	J1-A	-	T01-0	11	1	13	
P50C16	T01-0	11	S3-2	0	1	30	
P50D16	W1-(-)	0	S3-2	0	1	23	
P50E16	W1-(-)	0	B2-(-)	0	2	7	
P50F16	W2-(-)	0	W2-(-)	0	2	25	
P50G16	W5-(-)	4	B3-(-)	0	2	6.5	
P55816	J1-1	-	T01-2	11	1	10	
P55C16	T01-2	5	B51-1	4	2	47	
P55D016	B51-1	4	B52-1	4	2	9.5	
P55E16	B52-1	4	B53-1	4	2	17	
P55F16	W5-(-)	4	B53-1	4	2	30	
P55G16	W5-(-)	4	B56-1	4 STRIP	2	14	
P55H16	B56-1	4 STRIP	B57-1	4 STRIP	2	16.5	
P55816	J1-B	-	W1-CASE	5	1	47	
P55816	A4-2	11	T01-4	11	1	10.5	
P55816	T01-4	5	B58-1	1/4 STRIP	2	50	
P55816	S3-3	0	S3-6	0	1	7	
P56816	J1-A	-	S3-2	0	1	31	
P57816	S7-2	0	S3-5	0	1	10	
P57C16	J1-E	-	S7-2	0	1	20	
P62816	J1-A	-	S7-3	0	1	30.5	
P66E16	J1-A	-	A4-0	11	1	25	
P99816	J1-A	-	B56-2	1/4 STRIP	2	72	
P19816	J1-C	-	B50-2	1/4 STRIP	2	40	
R7016	J1-E	-	A1-01	4	2	23.5	BLACK
R8216	J1-F	-	A1-02	4	2	23.5	
R8216	J1-2	-	T01-6	11	1	12	
R8F16	T01-7	5	A1-03	4	2	12	
R8C16	A2-2	4	T01-6	5	2	12.5	
X124816	J1-P	-	S6-11	4	2	36	
X195816	J1-F	-	S6-10	4	2	36	
X197816	J1-W	-	S6-0	4	2	36	

WIRE BARRING NO	FROM		TO		WIRE FIND NO	CUT LENGTH IN	BARRING COLOR
	STATION NO	LUG FINE NO	STATION NO	LUG FINE NO			
129816	T01-7	5	B2-L	4 STRIP	2	42	BLACK
112016	J1-A	-	T01-1	11	1	9	
112E16	A2-1	4	T01-1	5	2	10	
112G16	T01-1	5	A4-5	5	2	7.5	
112H16	T01-1	5	S5-4	4	2	36	
112I16	T01-7	5	A1-03	4	2	15	
112K16	T01-2	5	S0-17	4	2	10	
112L16	A1-01	4	A1-02	4	2	5.5	
112M16	A1-02	4	A1-03	4	2	5.5	
114016	J1-6	-	B56-1	4	2	31	
114E16	S0-12	4	B56-1	4	2	10	
114F16	S0-12	4	S0-24	4	2	4.5	
115016	J1-A	-	B55-1	4	2	32.5	
115E16	S0-22	4	B55-1	4	2	20	
116016	J1-1	-	S0-13	4	2	34	
129816	J1-5	-	A4-12	5	2	23	
131816	J1-0	-	A4-4	5	2	14	
138816	A4-10	5	S5-3	4	2	51.5	
139816	A4-6	5	S5-0	4	2	40	
102816	S5-1	4	B2-0	0 STRIP	2	16	
102816	A4-11	5	S5-1	4	2	50	
190816	J1-U	-	S5-2	4	2	22	
X90816	S6-7	4	S5-2	4	2	11.5	
131816	J1-L	-	S5-5	4	2	32.5	

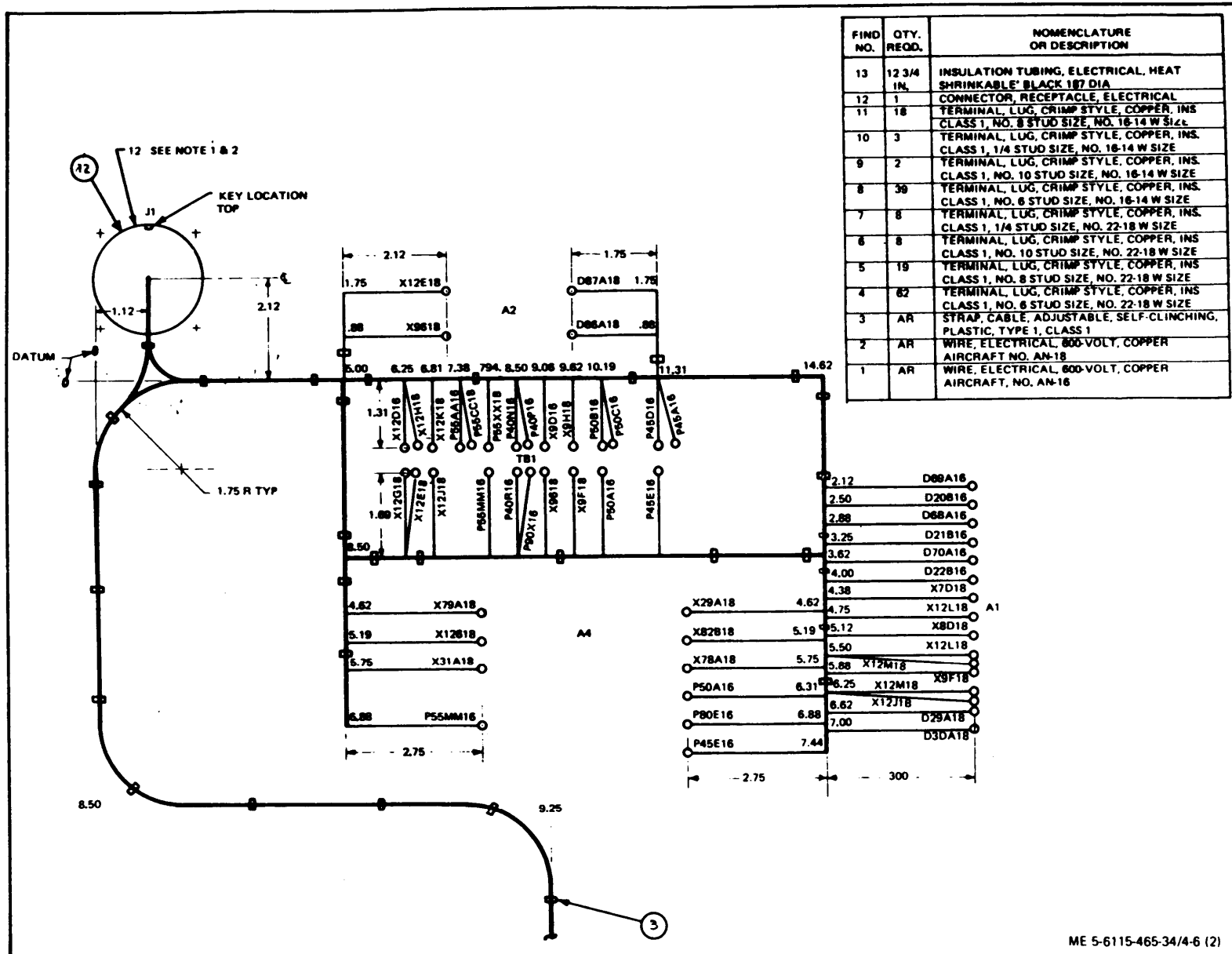

Figure 4-6. Control Cuticle Wiring Harness (Sheet 2 of 3) Drawing No. 69-677

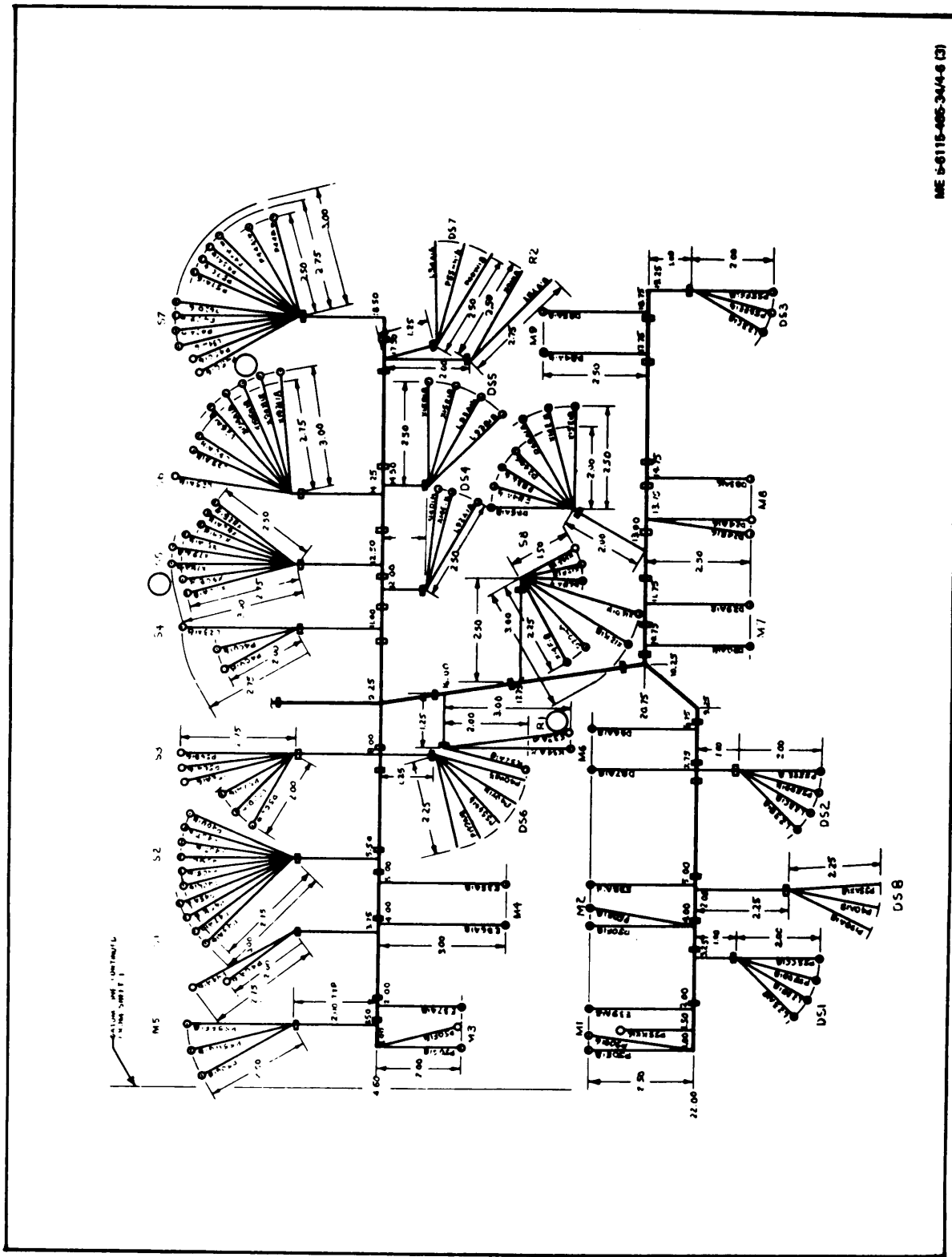

Figure 4-6. Control Cubicle Wiring Harness (Sheet 3 of 3) Drawing No. 69-677



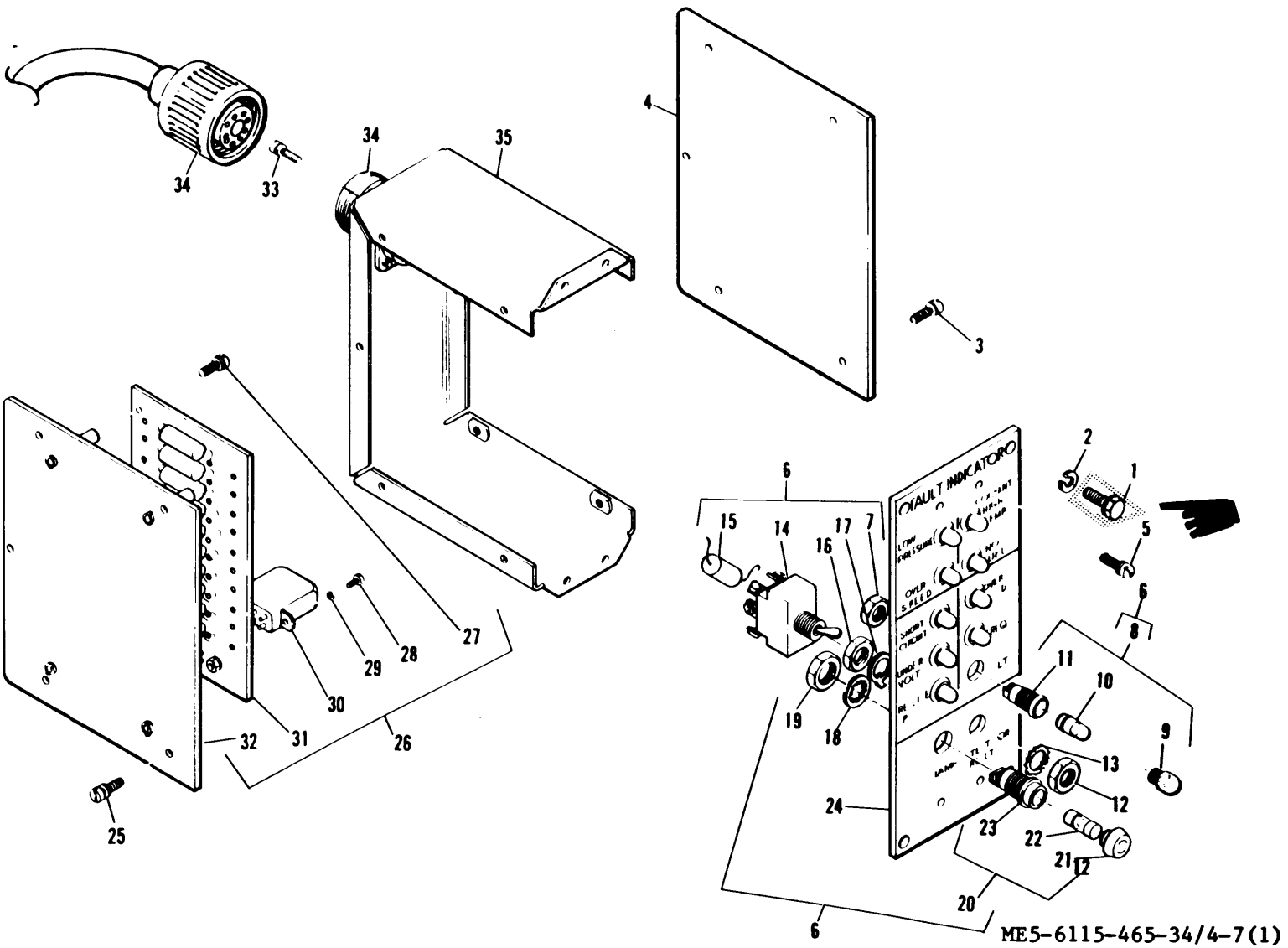

Figure 4-7. Fault Locating Indicator, Exploded View (Sheet 1 of 2)

Change 2

4-11

TM5-6115-465-34  
 NAVFAC P-8-625-34  
 T.O. 35C2-3-446-2  
 TM 06858B/06859D-34

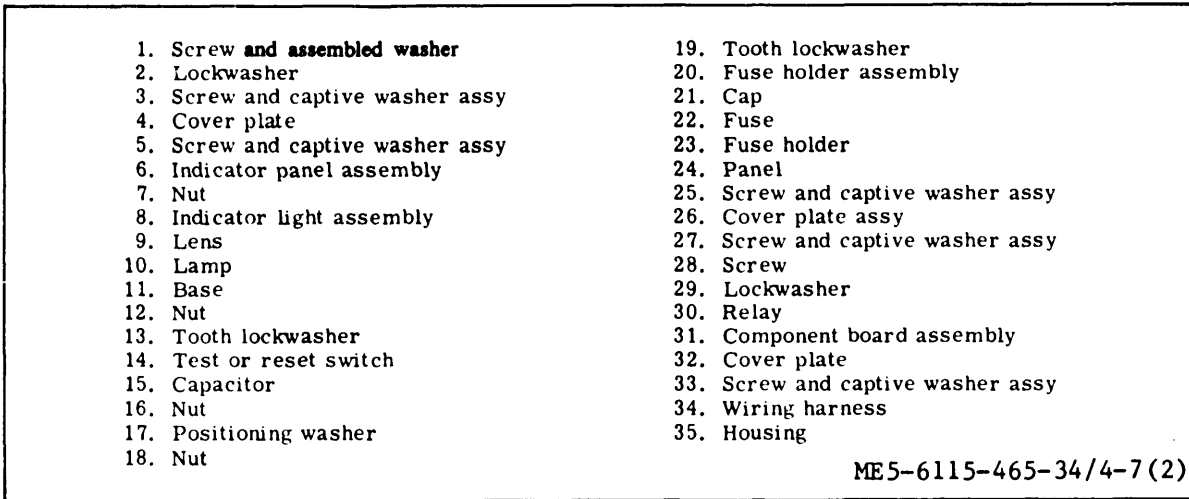

Figure 4-7. Fault Locating Indicator, Exploded View (Sheet 2 of 2)

(b) Inspect Indicator fights for cracked or damaged lens, defective lamp, and corroded or damaged base.

(c) Inspect fuse holder assembly for cracked or damaged cap, defective fuse, and burned, cracked or corroded fuse holder.

(d) Inspect, test, or reset switch for cracks, corrosion, and evidence of shorting.

(e) Check continuity of test or reset switch using figure 4-8 as a guide.

(5) Inspect component board assembly for burned components, damaged wires and cracked or broken board.

(6) Test individual components of component board using figures 4-8 and 4-9 and table 4-1 as a guide.

NOTE

Disconnect one lead to component being tested to avoid erroneous test readings.

(7) If any circuit board component must be replaced or encapsulating coating repaired or replaced, refer to Appendix A references for detailed procedures. Repair/replace encapsulation by applying a 0.007 inch (minimum) coating of polyurethane resin (Scotchcoat 221, Minnesota Mining and Mfg. Co., or equal).

NOTE

Prior to coating, deaerate resin by evacuating at room temperature to between 5 and 10 Hg absolute to remove air bubbles.

Table 4-1. COMPONENT BOARD TEST VALUES

COMPONENT	TEST VALUE
C1 through C10	0.10 UF ± 0.01 UF
CR1 through CR10	1N2610 (100PRV)
R1 through R10	2200 ± 220
R11 through R20	1000 ± 100
SCR1 through SCR10	2N1596

(8) Use an ohmmeter to test resistance of relay K1 (figure 4-8). Resistance shall be 300 ± 30 ohms. Replace relay if defective.

(9) Visually inspect fault locating wiring harness connector for cracks, corrosion, and loose or damaged pins.

(10) Check individual wires for corroded or damaged terminals, burned insulation and other damage.

(11) Check individual wires for continuity using figure 4-10 as a guide.

(12) If the wiring harness has sustained damage and requires repair or rebuild, refer to figure 4-10 for layout, identification, and material requirements and Appendix A for detailed soldering and replacement procedures.

d. Assembly. Assemble fault locating indicator in reverse order of disassembly procedures.

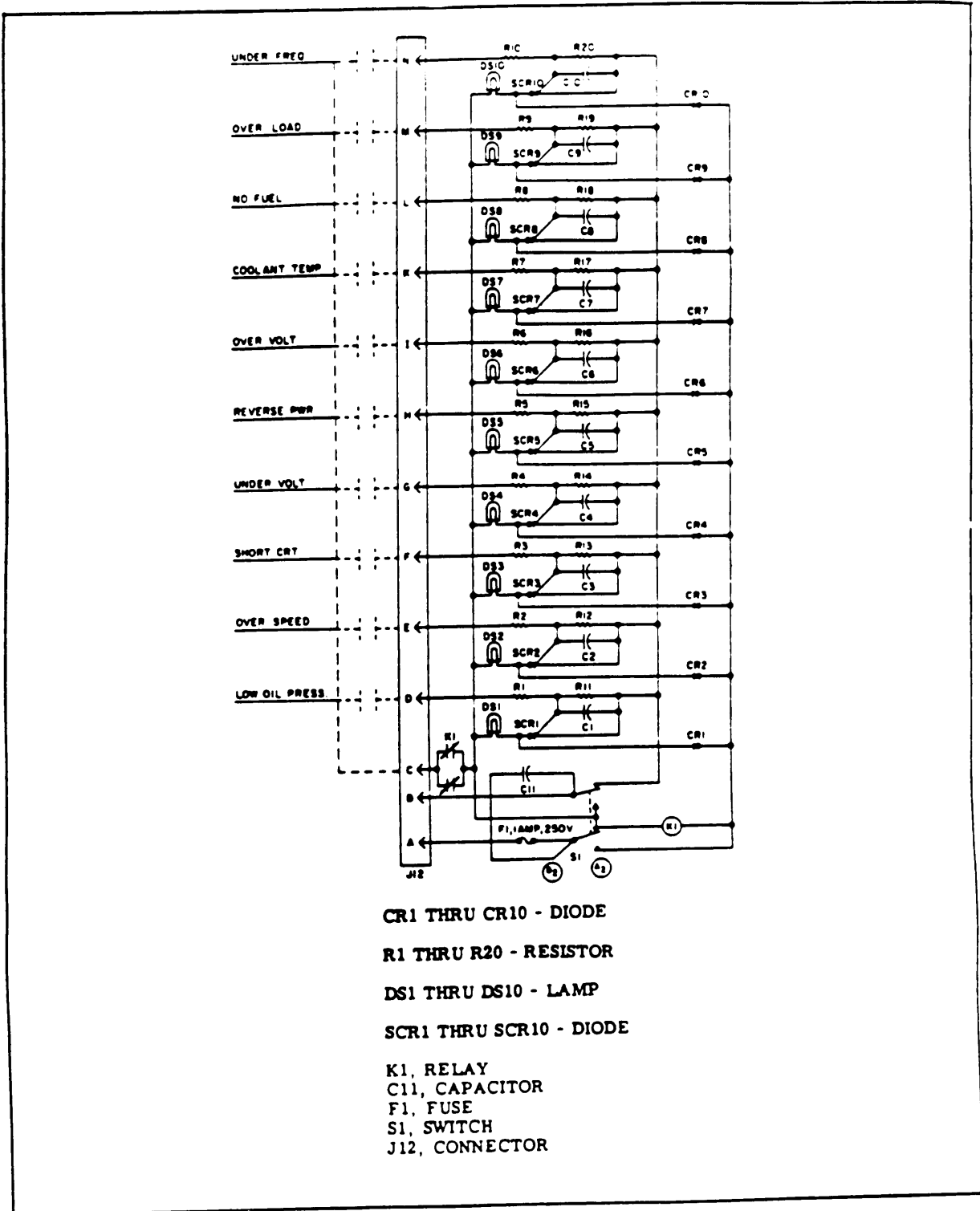
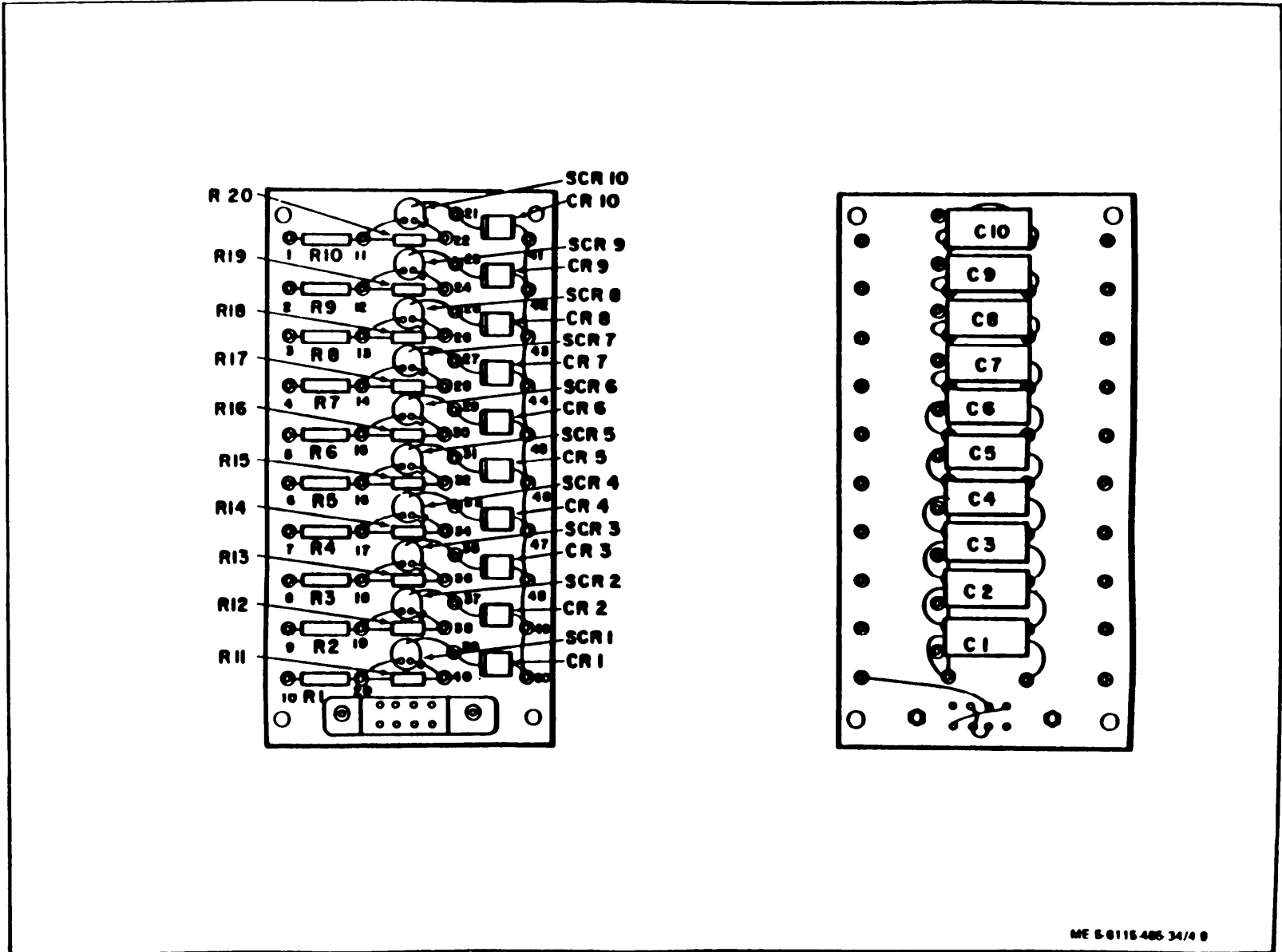

Figure 4-8. Fault Locating Indicator, Schematic Diagram



ME 5-6115-465-34/4 0

Figure 4-9. Fault Locating Indicator Component Board Assembly

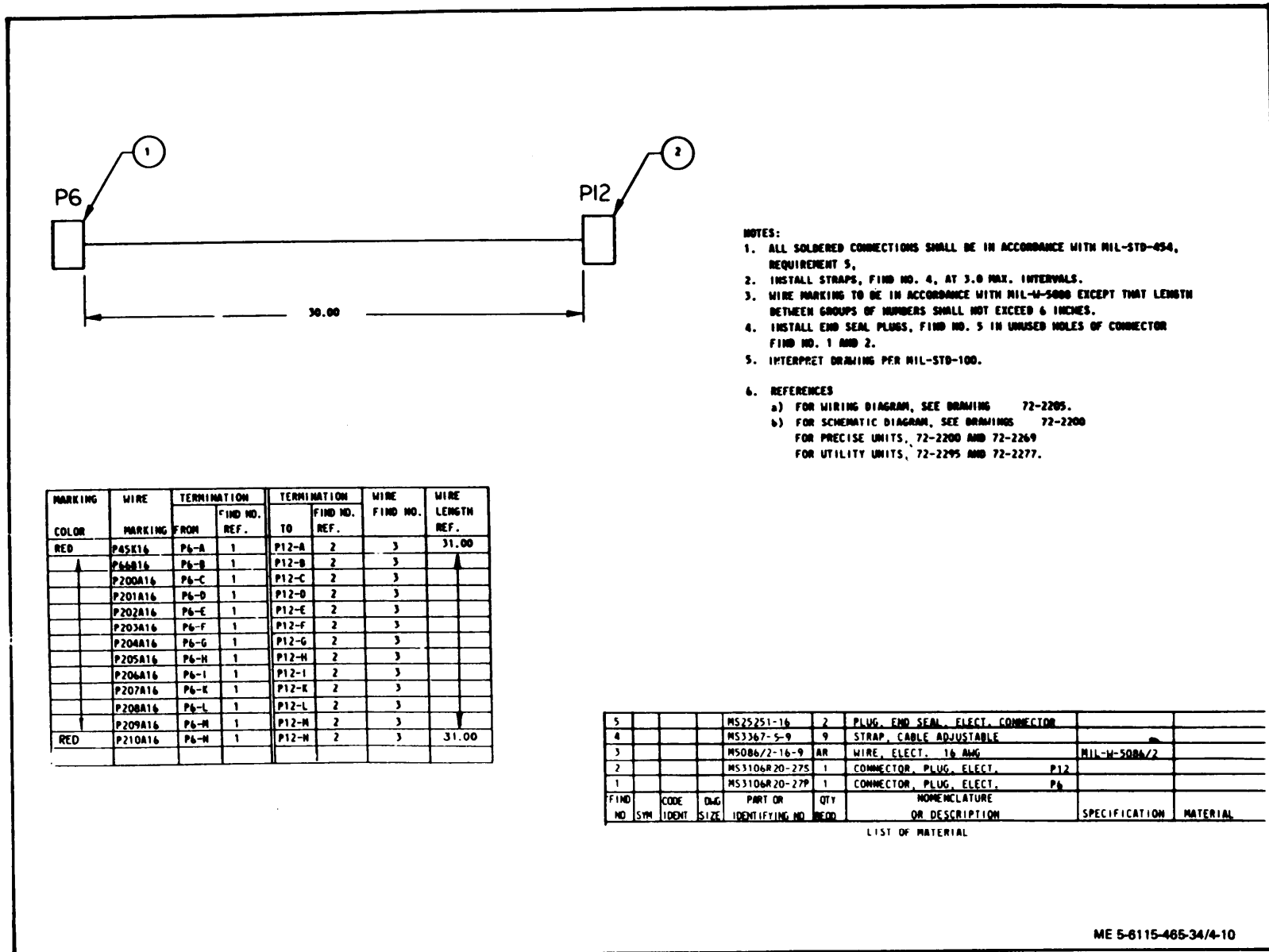
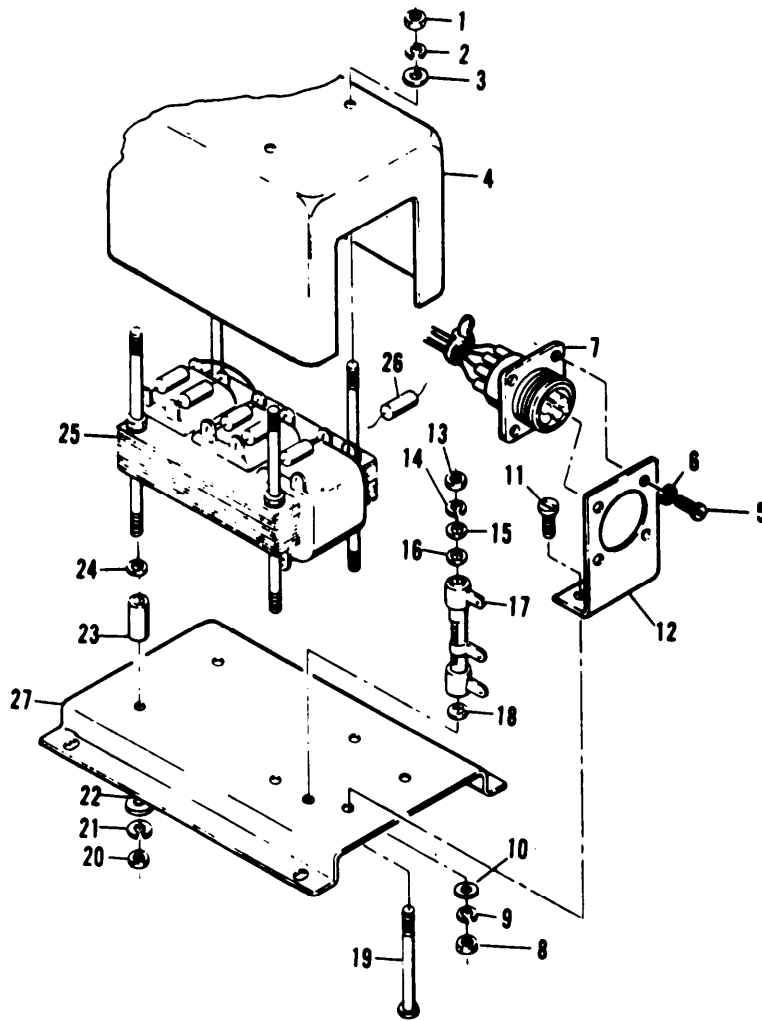

Figure 4-10. Fault Locating Indicator Wiring Harness Drawing No. 72-2247



- |                       |                       |
|-----------------------|-----------------------|
| 1. Nut                | 15. Flat washer       |
| 2. Lockwasher         | 16. Insulating washer |
| 3. Flat washer        | 17. Load resistor     |
| 4. Cover              | 18. Insulating washer |
| 5. Screw              | 19. Screw             |
| 6. Lockwasher         | 20. Nut               |
| 7. Connector          | 21. Lockwasher        |
| 8. Nut                | 22. Flat washer       |
| 9. Lockwasher         | 23. Spacer sleeve     |
| 10. Flat washer       | 24. Insulating washer |
| 11. Screw             | 25. Transformer       |
| 12. Connector bracket | 26. Diode             |
| 13. Nut               | 27. Base              |
| 14. Lockwasher        |                       |

ME 5-6115-465-34/4-11

Figure 4-11. Load Measuring Unit, Exploded View

e. Testing,

- (1) Refer to figure 4-8 and connect the positive lead of a 24 Vdc source to pin A of connector J12.
- (2) Connect the negative lead to pin B.
- (3) Place test or reset switch in the TEST or RESET position. All indicator lights shall illuminate.
- (4) Release test or reset switch. All indicator lights shall go dark.
- (5) Install a jumper between connector pins C and D. Low oil pressure indicator light shall illuminate.
- (6) Remove jumper from pin D. Low oil pressure indicator light shall remain lit.
- (7) Connect jumper between connector pins C and E and reset test or reset switch.
- (8) Low oil pressure indicator light shall go dark and overspeed indicator light shall illuminate.
- (9) Repeat steps (5) through (8) for connector pins F through N.
- (10) If any indicator light fails to function properly, disassemble fault locating indicator and test that portion pertinent to the malfunctioning light.

f. Installation. Install fault locating indicator in reverse order of removal procedures.

4-4. MANUAL SPEED CONTROL.

Refer to the Operator and Organizational Maintenance Manual for manual speed control maintenance instructions.

4-5. DC CONTROL CIRCUIT BREAKER.

Refer to the Operator and Organizational Maintenance Manual for dc control circuit breaker maintenance instructions.

4-6. LOAD MEASURING UNIT.

a. Removal. Refer to the Operator and Organizational Maintenance Manual for load measuring unit removal instructions.

b. Disassembly. Disassemble load measuring unit by following the ascending sequence of index numbers assigned to figure 4-11.

NOTE

Disassemble load measuring unit only as is necessary for inspection, testing, and replacement of components.

c. Cleaning and Inspection.

- (1) Clean all non-electrical metal parts in dry cleaning solvent (Federal Specification P-D-680) and dry with filtered compressed air.
- (2) Clean electrical components with filtered compressed air and a soft bristle brush.
- (3) Visually inspect cover connector bracket and base for cracks, corrosion, dents, and other damage.
- (4) Inspect load resistor for cracks, corrosion, burns, and evidence of overheating.
- (5) Inspect diodes for burns and other damage.
- (6) Inspect electrical connector for bent or broken pins, burns, cracks, and other damage.
- (7) Check all wiring for burned insulation, bare wires, broken, or loose connections and other damage.
- (8) If the wiring harness has sustained damage and requires repair or rebuild, refer to figure 4-12 for layout, identification, and material requirements and Appendix A for detailed soldering and replacement procedures.

d. Testing and Repair.

NOTE

Disconnect leads to components prior to testing to avoid erroneous readings.

(1) Test individual components using figure 4-13 as a guide and perform the following steps:

(a) Using a VOM, check for continuity between the following test points of transformer T1, figure 4-13: TP1 and TP2, TP8 and TP9, TP15 and TP16, TP5 and TP6, TP6 and TP7, TP5 and TP7, TP12 and TP13, TP13 and TP14, TP12 and TP14, TP19 and TP20, TP20 and TP21, and TP19 and TP21,

(b) If continuity is not indicated in all of the above checks and open circuit exists in the transformer windings, replace transformer (25, figure 4-11).

NOTE

Continuity of secondary windings of transformer T1 can be checked by using pins K and A, L and B, and M and C of plug P7 if desired. This method could show continuity if the connector P7 is faulty, even though the transformer has an open winding.

(c) Using a VOM, check for open circuit indications (infinity) between the following test points

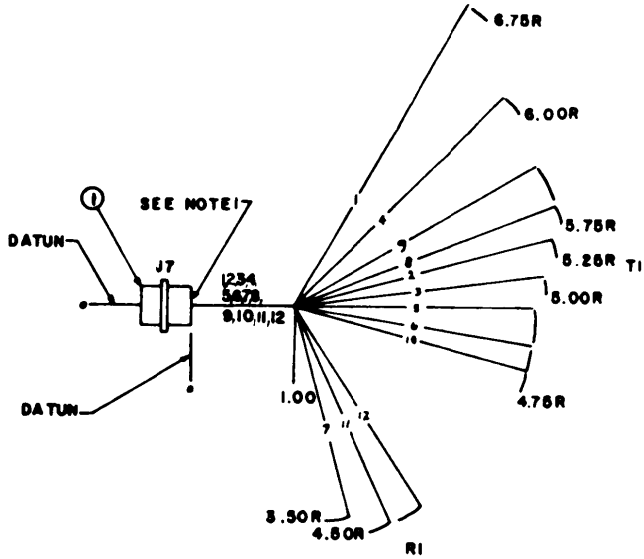

NOTES:

1. INSTALL INSULATION SLEEVING, FIND NO. 4 OVER EACH SOLDERED CONNECTION AND HEAT SHRINK TO A FIRM FIT. SLEEVING SHALL EXTEND OVER WIRE INSULATION A MINIMUM OF .25 INCH.
2. ALL SOLDERED CONNECTIONS SHALL BE IN ACCORDANCE WITH MIL-STD-454, REQUIREMENT 5.
3. CONDUCTOR ENDS WITHOUT TERMINALS OR CONNECTORS SHALL BE STRIPPED .25 INCH AND TRIMMED IN ACCORDANCE WITH MIL-STD-454, REQUIREMENT 5.
4. EACH WIRE SHALL BE PERMANENTLY AND LEGIBLY IDENTIFIED AT EACH END OF THE WIRE.
5. REFERENCES:  
 9.1 FOR LMU ASSEMBLY SEE DWG 69-500  
 9.2 FOR WIRING DIAGRAM SEE DWG 69-510  
 9.3 FOR SCHEMATIC DIAGRAM SEE DWG 69-509
6. FOR INTERPRETATION OF DRAWING SEE MIL-STD-100.
7. INSTALL CABLE STRAP, FIND NO. 3. 1.00 INCH DROM CONNECTOR J 7. FIND NO. 1. REMOVE EXCESS LENGTH OF STRAP.

FIND NO.	SYM	CODE IDENT	DWG SIZE	PART OR IDENTIFYING NO.	QTY REQD	NOMENCLATURE OR DESCRIPTION	SPEC	MATERIAL
1	M, A		B	69-502-2	1	CONNECTOR, RECPT.		
2	B				AR	WIRE, ELEC. TYPE C20, 105 C 1000 V	MIL-W-16878/2	
3				MS3367-2-9	1	STRAP, CABLE, ADJ. SELF-CLINCHING, PLASTIC, TYPE 1, CL 1, 4 MAX BOL DIA, NATURAL		
4	B			CL 1	AR	INSULATION SLEEVING, ELEC, SHRINKABLE POLY-VINYL CHLORIDE, FLEX., CROSSLINKED .093 MIN 10, AS SUPPLIED, .046 MAX I.D. X .020 NOM WALL, AFTER SHRINKAGE.		

WIRE NO. REF.	TERMINATION		WIRE CUT LENGTH REF
	FROM	TO	
1	17-A	T1-2	8.25
2	J7-B	T1-9	6.75
3	J7-C	T1-16	6.50
4	J7-D	T1-6	7.50
5	J7-E	T1-13	6.25
6	J7-F	T1-20	6.25
7	J7-G	R1-3	5.00
8	J7-H	T1-1	7.25
9	J7-K	T1-8	7.25
10	J7-M	T1-15	6.25
11	J7-N	R1-1	6.00
12	J7-S	R1-2	6.00



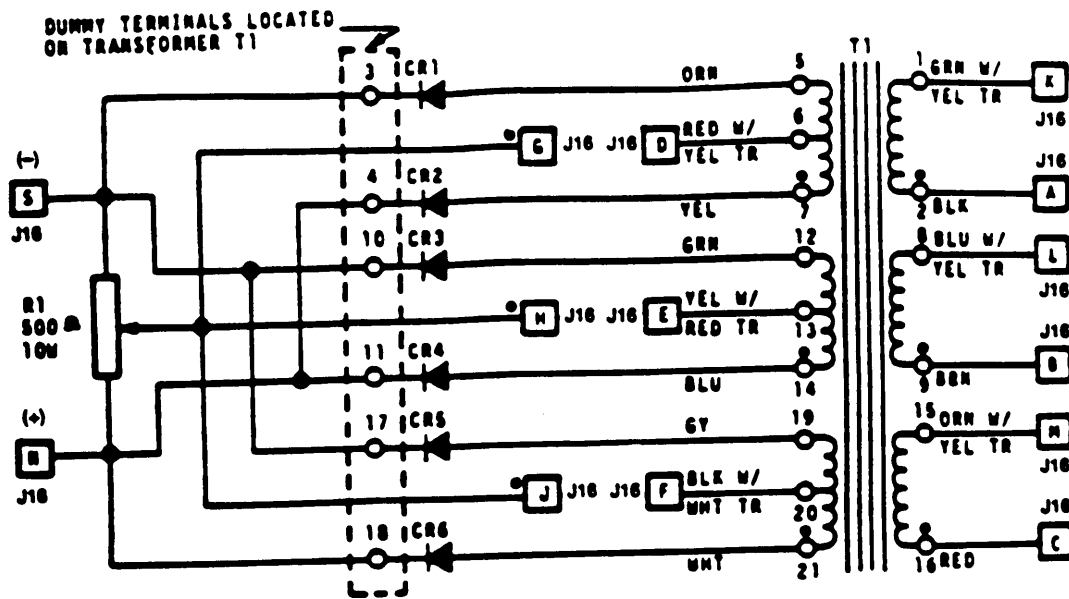

**LEGEND**

- CR1 -- Diode
- CR2 -- Diode
- CR3 -- Diode
- CR4 -- Diode
- CR5 -- Diode
- CR6 -- Diode
- T1 --- Transformer
- P7 --- Plug (Mating plug to J16 of wiring harness)
- R1 --- Resistor

1 through 21 are connections and test points for Diodes CR1 through CR6 and Transformer T1

Figure 4-13 Load Measuring Unit Component Test and Replacements Diagram

of transformer T1, figure 4-13: TP1 and TP5, TP1 and TP6, TP1 and TP7, TP2 and TP5, TP2 and TP6, TP2 and TP7, TP8 and TP12, TP8 and TP13, TP8 and TP14, TP9 and TP12, TP9 and TP13, TP9 and TP14, TP15 and TP19, TP15 and TP20, TP15 and TP21, TP16 and TP19, TP16 and TP20, TP16 and TP21, TP7 and TP12, TP14 and TP19, TP2 and TP8, TP9 and TP15.

(d) If continuity is indicated in any of the above checks, replace the transformer (25, figure 4-11).

(e) Using a VOM, check diodes (1 through 6, figure 4-13). Check diode CR1 by placing the positive probe of the VOM on TP3 and the negative probe on TP5. The VOM should indicate continuity. Reverse the probes: the VOM should indicate open circuit. If the diode fails either of these tests, replace the diode (26, figure 4-11).

(f) Check the remaining diodes, CR2 through CR6 using the same procedure. Replace any diodes found to be defective.

(2) Install load measuring unit in the test circuit shown in figure 4-14.

(3) Remove load measuring unit cover.

(4) Adjust load bank R1 so that it will apply no load to power source G1.

(5) Activate power source and adjust to obtain a reading of 208 Vac on voltmeter M1.

(6) Adjust load measuring unit load resistor (17, figure 4-11) to obtain a reading of 0.0 to 0.4 Vdc on voltmeter M2 (figure 4-14).

(7) Place load bank on the line and check reading of voltmeters M2 and M3. Readings shall be  $9.6 \pm 0.2$  Vdc and 5.4 Vac respectively.

(8) Slowly adjust load bank from zero to full load while observing voltmeters M2 and M3. Indication of voltmeter M2 shall vary from 0.0 to  $9.6 \pm 0.2$  Vdc as indication of voltmeter M3 varies from  $0.2 \pm 0.2$  to 5.6 Vac (figure 4-14).

(9) If necessary, adjust load measuring unit load resistor (17, figure 4-11) to obtain the relationship shown in figure 4-14.

(10) If adjustment does not give the proper relationship or if relationship varies outside of acceptability limits at any point, replace load measuring unit load resistor.

(11) Deactivate power source and remove load measuring unit from test circuit.

(12) Install load measuring unit cover (figure 4-11).

e. Assembly. Assemble load measuring unit in reverse order of disassembly procedures.

f. Installation. Refer to the Operator and Organizational Maintenance Manual for load measuring unit installation instructions.

#### 4-7. GOVERNOR CONTROL UNIT. (MEP 104A)

##### a. General.

(1) The electro-hydraulic governing system is a speed (frequency) sensing system used to maintain prime mover speed constant and therefore generator output frequency, during periods of unchanging load and when load additions or deletions occur.

(2) The system consists of a control unit, load measuring unit and hydraulic throttle actuating unit.

(3) The control unit inputs are the generator output voltage, and a dc voltage (0-9.8 Vdc) proportional to the generator load, supplied by the load measuring unit. The generator voltage input is applied to a frequency sensing network and reference voltage network. The differential output of these two networks determines the control current of two magnetic amplifiers whose outputs drive separate coils of the hydraulic actuators' pilot valve. The actuator pilot valve positions the actuator power piston which is connected to the input arm of the fuel injection pump. The actuators' hydraulic system is comprised of a reservoir, engine driven pump (300-320 psi, 2 gpm), cooler and filter.

(4) Any deviation of engine speed, reflected as a change in frequency at the input of the governor, produces a change in the magnitude and direction of magnetic amplifier control field current. This change in control field current will increase the strength of one coil of the pilot valve while decreasing the strength of the other. The resultant difference repositions the pilot valve in turn repositioning the power piston which changes the output of the fuel injection pump, changing engine speed and consequently restoring generator frequency to its nominal value.

(5) The load measuring unit (LMU) input to the governor control provides for automatic load sharing when two or more sets are operated in parallel. Each set is equipped with an LMU.

(6) If the load added to the system is not equally divided, the LMU inputs to their respective governors will differ. The resulting difference acting through additional windings of each set's governor (which are connected in parallel) will reposition each set's actuator power piston such that fuel flow in the more lightly loaded set is increased. Since the power input of each prime mover has been readjusted, equal division of true power (kW) occurs with no deviation in frequency of any set.

b. Malfunction. The following procedures are to be performed in the generator set unless otherwise specified.

**LEGEND:**

- G1. POWER SOURCE, 208 VAC, 3 PHASE, 47-430 HZ**
- M1 VOLTMETER, 0-250 VAC**
- M2 VOLTMETER, 0-10 VDC**
- M3 VOLTMETER, 0-10 VAC**
- R1 LOAD BANK**
- R2 LOAD RESISTOR, 7.5 OHM, 10 WATT**
- R3 LOAD RESISTOR, 7.5 OHM, 10 WATT**
- R4 LOAD RESISTOR, 7.5 OHM, 10 WATT**
- T1 TRANSFORMER**
- T2 TRANSFORMER**
- T3 TRANSFORMER**

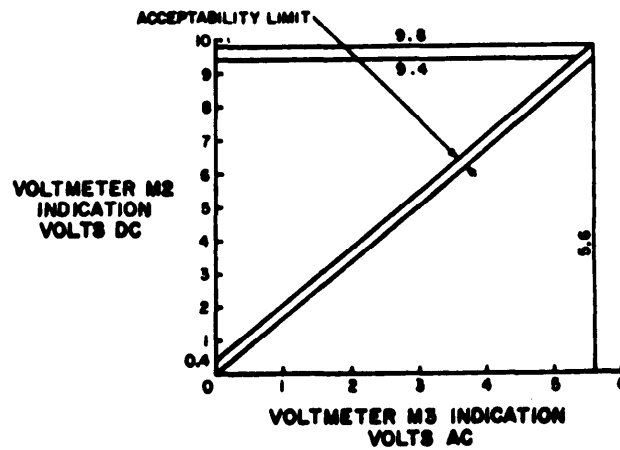
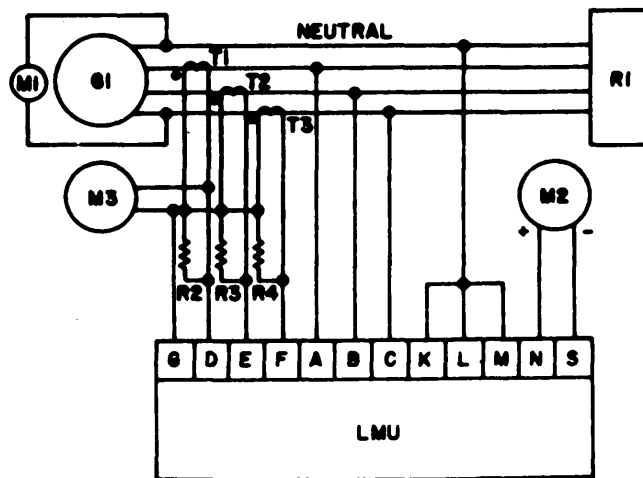

ME 5-6115-465-34/4-14

Figure 4-14. Load Measuring Unit Test Circuit and Test Data Relationship

(1) If the FL - NL or NL - FL transient exceeds 1-1/2 percent of rated speed and/or does not re-establish stable engine operating conditions within one second, realign the control unit in accordance with paragraph 4-7j. Also follow this procedure if the engine speed hunts. If the set cannot be stabilized, check sockets A and B of plug P-21 (figure 4-38) for 24 Vdc (A is positive).

(2) If the engine speed increase to above nominal operating speed, check sockets A and B of P-17 (figure 4-38) for 120 Vat. If it is missing, troubleshoot the generator set wiring. Refer to schematic and troubleshooting diagram plates located on inside of left and right engine compartment doors (figure 4-38). If it is present, check the resistance of the frequency adjusting circuit consisting of R4 (250 ohms) rheostat R1 frequency adjust (500 ohms) and R6 (250 ohms) fixed resistor. Measure the total circuit resistance across N and T of harness plug P17 (figure 4-38). The circuit resistance should be 1000 ohms (5 percent tolerance). After testing for correct total resistance, test the operation of the frequency adjust rheostat by connecting an ohmmeter across pins M and T and revolving the frequency adjust rheostat through its entire travel. The resistance should vary from 750 ohms to 250 ohms. Repeat this procedure using the ohmmeter across pins M and N of the harness plug. If the problem persists, check sockets A and B of plug P-21 (figure 4-38) for 24 Vdc (A is positive).

(3) If the engine speed remains below the nominal operating speed, adjust R 1. If there is no improvement, check the resistance of the frequency adjust circuit. Disconnect P-17 and check the resistance of the frequency adjust circuit consisting of R4 (250 ohms) fixed resistor, R1 frequency adjust rheostat (500 ohms) and R5 (250 ohms, 5 percent) fixed resistor. Measure the total circuit resistance across N and T of harness plug P-17. The circuit resistance should be 1000 ohms (5 percent tolerance). After testing for correct total resistance, test the operation of the frequency adjust potentiometer by connecting an ohmmeter across pins M and T and revolving the travel. The resistance should vary from 750 ohms to 250 ohms. Repeat this procedure using the ohmmeter across pins M and N of the harness plug. Disconnect actuator electrical connector before making this measurement. Push actuator piston all the way down and adjust engine speed with manual throttle. If this value resistance is measured, check sockets A and B at plug P-21 for 24 Vdc (A is positive).

(4) If the set is operating at a constant load and voltage and during an eight-hour period the change in ambient temperature does not exceed 60 F, the set frequency should not drift beyond 1/2 of one percent of rated frequency. The above requirement assumes that the set temperatures were stabilized at the initial and final ambient temperatures.

#### NOTE

If the drift in paragraph (4) is excessive, realign the control unit following the procedure outlined in paragraph 4- 7j.

(5) At constant ambient temperature, constant load, constant voltage and constant barometric pressure, the set frequency should remain within a bandwidth of 1 percent of rated frequency for a period of 4 hours. If this bandwidth has been exceeded, realign the control unit in accordance with paragraph 4-7j.

(6) If the preceding solutions to the specific problem do not resolve the problems, replace and repair the control unit, actuator (paragraph 3-42), or load measuring unit (paragraph 4-6) as required.

#### c. Removal.

(1) Tag and disconnect electrical connectors to governor control unit.

(2) Remove nuts (1, figure 4-15), lockwashers (2), nuts (3), lockwashers (4) and bracket (5), threaded rod (6) and lift governor control unit from mounting bracket.

#### d. Disassembly.

(1) Disassemble governor control unit (7 through 58) only as is necessary for inspection, testing, and replacement of parts.

#### NOTE

Disassembly and repair of the electric governor control unit at the field level is restricted to removal of the cover, connectors, potentiometers and test jacks. Further disassembly requires unpotting which can be performed by depot maintenance personnel only.

(2) Remove screws (7) and lockwashers (8) and carefully lift cover and situate at angle to prevent potting compound from contacting variable resistors and connectors.

#### CAUTION

Flash point of potting compound is 515°F (268.3 C). Do not allow oven to reach this temperature. The melting temperature of potting compound is 165°F (73.8 C).

(3) Place governor control unit in oven and bake at +180°F to 185°F (+82.2 C to +85 C) for 11 to 12 hours.

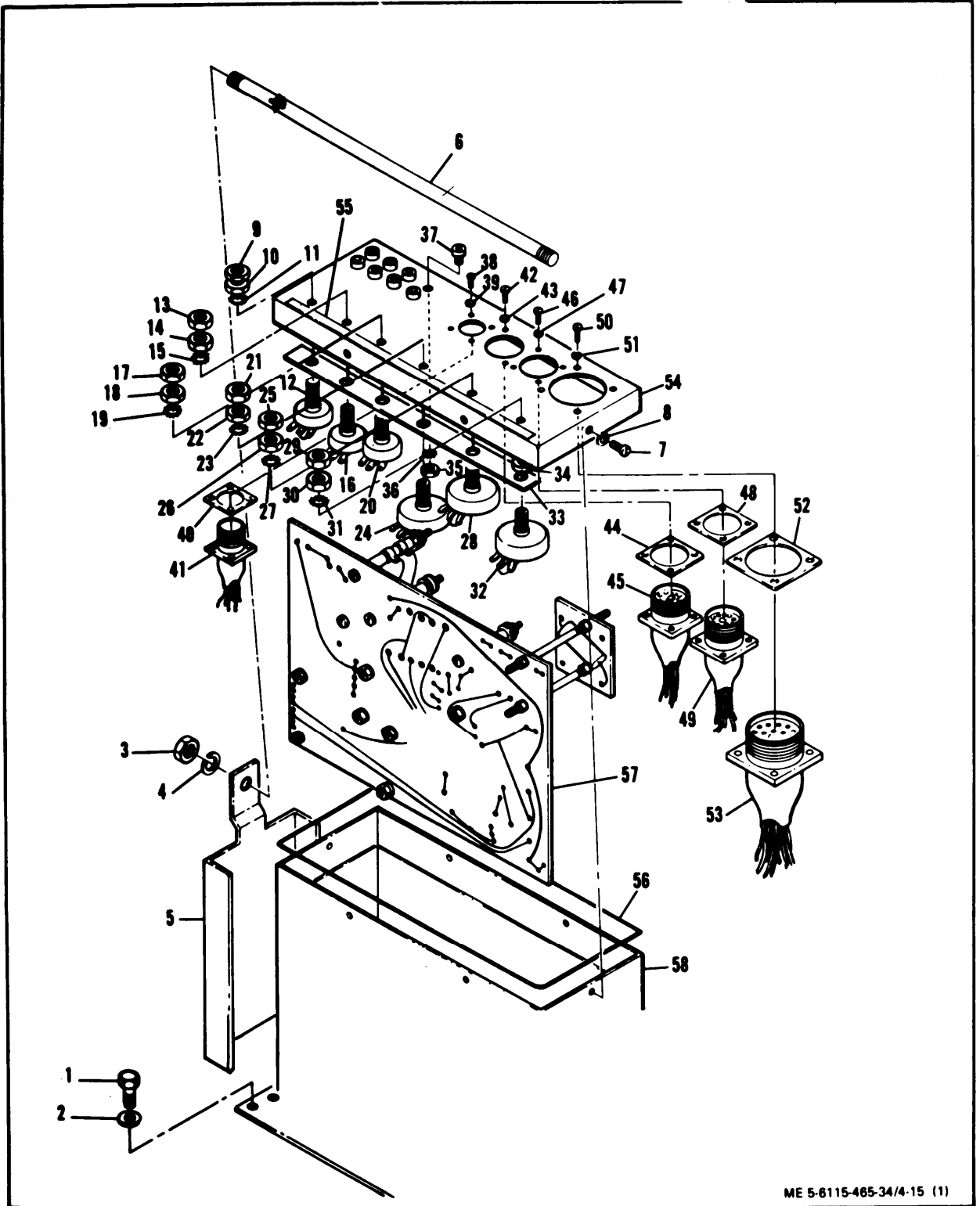

ME 5-6115-465-34/4-15 (1)

Figure 4-15. Governor Control Unit, Exploded View (Sheet 1 of 2)

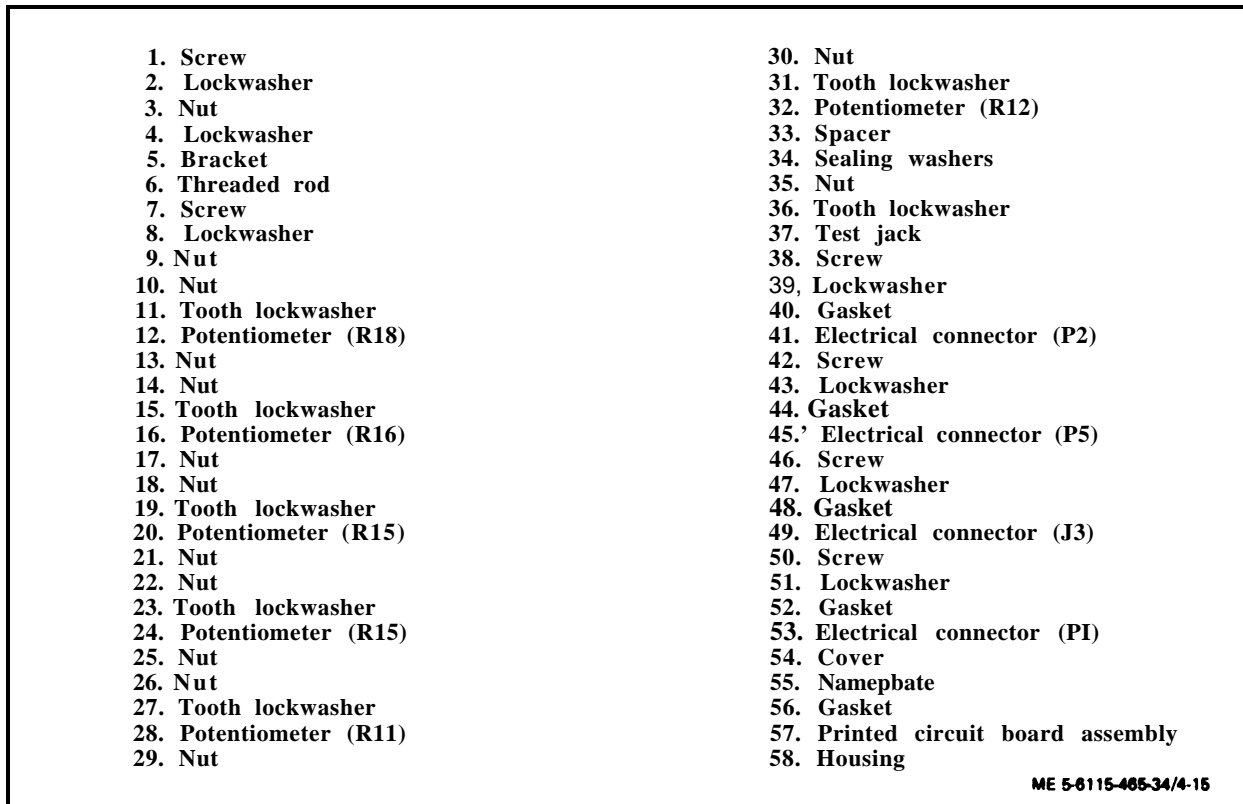

Figure 4-15. Governor Control Unit, Exploded View (Sheet 2 of 2)

**WARNING**

Wear protective glasses and asbestos gloves when removing governor control unit. Hot potting compound will cause severe burns should it come in contact with the skin.

- (4) Remove governor control unit from oven.
- (5) Slowly lift cover (54) with attached parts and printed circuit board (57) from housing (58).
- (6) Place printed circuit board on a drain board and allow to cool.
- (7) Remove screws (38, 42, 46, and 50) and lockwashers (39, 43, 47, and 51) attaching connectors (41, 45, 59, and 53), gaskets (40, 44, 48, and 52) and cover (54).
- (8) Disassemble remaining components mounted on cover in accordance with index numbers 9 through 37.

e. Cleaning, Inspection, and Repair.

- (1) Clean housing and cover with dry cleaning solvent (Federal Specification P-D-680) and dry with filtered compressed air.
- (2) Clean electrical components with a clean, Lint-free cloth lightly moistened with an approved solvent.
- (3) Visually inspect cover and housing for cracks, dents, defective paint and other damage.
- (4) Inspect potentiometers for cracks, lawns, and other damage.
- (5) Inspect electrical connectors for bent or broken pins, cracks, burns, and other damage.
- (6) Inspect printed circuit board assembly for cracks, breaks, burned or damaged components and cold solder joints.
- (7) Inspect all wiring for burned, chaffed, or damaged insulation and loose connections.

(8) Repair housing and cover as follows:

(a) Straighten dents and warping.

(b) Remove defective paint and corrosion. Treat and paint.

(9) Repair wiring harness as follows: If the wiring harness has sustained damage and requires repair or rebuild, refer to figures 4-16 (50/60Hz as required for layout identification and material requirements and Appendix A for detailed soldering and replacement procedures.

(10) Test and replace printed circuit board components using figures 4-18, 4-19, 4-20, 4-21, and 4-22 as appropriate.

(11) If any soldered component on the printed circuit board must be replaced, refer to Appendix A for detailed soldering and replacement procedures.

f. Assembly.

(1) Assemble governor control unit in reverse order of removal procedures using figure 4-15 as a guide.

NOTE

Prior to installing assembled governor control unit in housing and pouring potting compound, perform tests (subparagraph g.) below.

(2) After completing assembly, repeat tests g.(2), (3), (4) (checks only), (5) and (6).

(3) After final assembly, use an ohmmeter to check for open circuit between each pin on all connectors and each test point and the governor control unit housing. There shall be no sign of continuity.

g. Testing.

CAUTION

Unpotted governor control unit printed circuit board must be positioned as specified in step (1) below.

(1) Position governor control unit printed circuit board as shown in figure 4-23.

(2) Perform resistance test as follows:

(a) Turn potentiometers (R11, R12, R14, R15, R16 and R18, figure 4-15) to the full clockwise position.

(b) Preset adjustable resistors (R2 and R10, figure 4-18) to mid-range.

(c) Using an ohmmeter, check resistance of points in table 4-2 for specified values.

NOTE

Observe polarity of connections specified in the table. Return potentiometer to clockwise position after each check.

(3) Perform magnetic amplifier bias test as follows:

(a) Install governor control unit in test circuit illustrated in figure 4-24.

NOTE

Frequency of power source (G1) must conform to frequency of governor control unit being tested.

(b) Turn potentiometers R11, R12, R14, R15, R16, and R18 to full clockwise position.

(c) Adjust R11 and R12 to obtain a balanced reading of 450 milliamperes on M2 and M3.

(d) Turn R12 to full clockwise. Reading of M2 and M3 shall be 0 to 300 milliamperes and shall be balanced within 50 milliamperes.

(e) Turn R12 to full counterclockwise position. Reading of M2 and M3 shall be 600-1000 milliamperes and be balanced within 50 milliamperes.

(f) Adjust R11 and R12 as in step(c) above and lock for remainder of test.

(4) Perform frequency sensing test as follows:

(a) Install the governor control unit in test circuit as shown in figure 4-25.

(b) Apply 5705 to 62.5 Hz,  $120 \pm 2$  volts ac to P1-A and P1-B.

(c) Adjust Rb so the resistance between P1-M and P-T is 250 ohms.

(d) Reduce the frequency of the applied  $120 \pm 2$  volt supply until M2 and M3 balance. The frequency shall be 57-58Hz (375 to 425 Hz on 400 Hz sets).

(e) Adjust Rb so the resistance between P1-M and P1-N is 250 ohms.

(f) Increase the frequency of the applied  $120 \pm 2$  volt supply until M2 and M3 balance. The frequency shall be 64-65 Hz.

{5} Perform rectifier bridge and feedback winding tests as follows.

Table 4-2. 50/60 Hz GOVERNOR CONTROL UNIT RESISTANCE TEST VALUES

<u>P1 CONNECTION</u>	<u>POTENTIOMETER POSITION</u>	<u>NOMINAL RESISTANCE (OHMS)</u>	<u>ALLOWABLE RESISTANCE RANGE (OHMS)</u>
(T-N) (T+)		5100	3400 - 6800
M-N (M+)	R18 counterclockwise	2180	1950 - 2400
(M+)		12,180	11,000 - 13,000
F-N (F+)	R16 counterclwkwise	6000	5000 - 7000
(F+)		31,000	30,000 - 32,000
(F+)	R15 counterclockwise	6500	5500 - 7500
E-G (E+)		5500	4500 - 6500
R-G (R+)		120	100 - 140
F-G (F+)		650	500 - 750
J-H (J+)		Less than 0.2 ohm	
T-P (T+)		2200	1400 - 3000
(T+)	R14 counterclockwise	2600	1800 - 3400
U-S (U+)		525	450 - 600

Table 4-3. 400 Hz ELECTRO-HYDRAULIC GOVERNOR CONTROL UNIT RESISTANCE TEST VALUES

<u>P1 CONNECTION</u>	<u>POTENTIOMETER POSITION</u>	<u>NOMINAL RESISTANCE (OHMS)</u>	<u>ALLOWABLE RESISTANCE RANGE (OHMS)</u>
(T-N) (T+)		4850	3400 - 6300
M-N (M+)	R18 counterclockwise	1400	1200 - 1700
(M+)		11,480	10,000 - 12,000
F-N (F+)	R16 counterclockwise	4160	3500 - 5500
(F+)		29,160	27,000 - 319000
(F+)	R15 counterclockwise	4660	4000 - 5500
E-G (E+)		5500	4500 - 6500
R-G (R+)		120	100 - 140
F-G (F+)		650	550 - 750
J-H (J+)		Less than 0.2 ohm	
T-P (T+)	R14 counterclockwise	1950	1400 - 2500
(T+)		2150	1500 - 2800
U-S (U+)		520	450 - 600



Figure 4-16. 50/60 Hz Governor Control Unit Wiring Harness, Drawing No. 69-731 (Sheet 1 of 2)

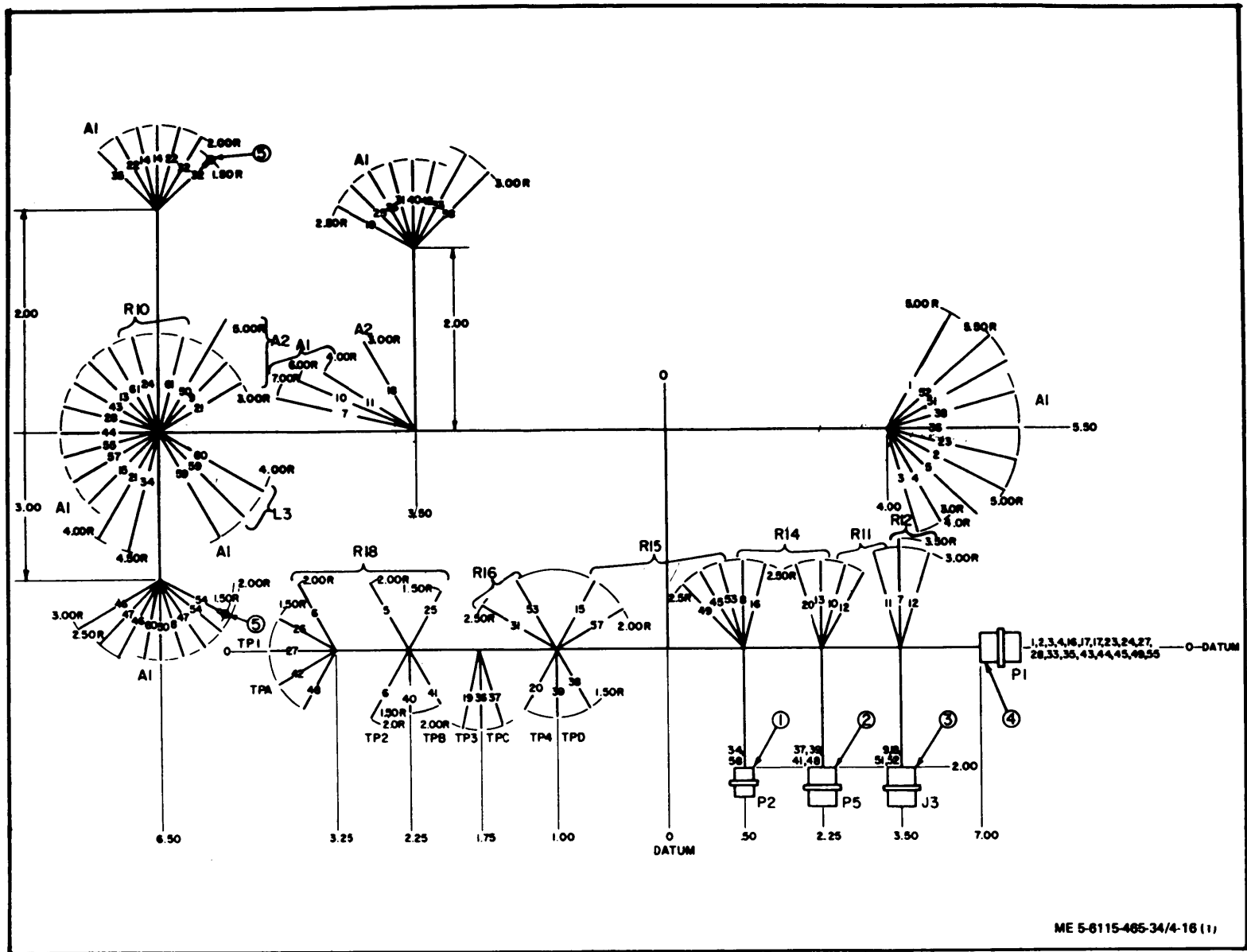

ME 5-6115-465-34/4-16 (1)

TM 5-6115-465-34  
 TO 35C2-3-446-2  
 NAVFAC P-8-625-34  
 TM 06858B/0685WY34

TERMINATION			TERMINATION			WIRE CUT-LENGTH (REF)
WIRE NO. (REF)	FROM	TERM. FIND NO' (REF)	TO	TERM. FIND NO. (REF)	WIRE FIND NO.	
1	P1-B		A1-1		6	22.00
2	P1-A		A1-2		6	22.00
3	P1-K		A1-3		6	20.00
4	P1-L		A1-4		6	20.00
5	R1B-2		A1-5		6	18.50
6	TP2		R1B-1		6	8.00
7	R12-3		A1-7		6	24.00
8	R14-1		A1-8		6	20.50
9	J3-A		A2-B		6	21.50
10	R11-1		A1-10		6	20.00
11	R11-3		A1-11		6	20.00
12	R11-2		R12-1		6	7.00
13	R14-3		A1-13		6	20.00
14	Q1-E		A1-E1		6	4.50
15	R15-1		A1-15		6	18.50
16	P1-P		R14-2		6	11.00
17	P1-H		P1-J		6	2.80
18	J3-B		A2-A		6	21.00
19	TP3		A1-19		6	18.00
20	TP4		R14-2		6	8.00
21	A2-D		A1-21		6	7.80
22	Q1-B		A1-81		6	4.50
23	P1-N		A1-23		6	22.00
24	P1-T		R10-1		6	23.00
25	R1B-3		A1-25		6	19.00
26	TP1		A1-26		6	20.00
27	P1-M		TP1		6	13.00
28	P1-G		A1-28		6	23.00
31	R1B-2	5	A1-31		6	19.00
32	Q1-C		A1-C1		6	4.00
33	P1-C		A1-33		6	22.00
34	P2-A		A1-34		6	20.00
35	P1-D		A1-35		6	24.00
36	TRC		A1-36		6	19.00
37	P5-C		TRC		6	8.50
38	TRD		A1-38		6	18.00
39	P6-D		TRD		6	7.00
40	TP5		A1-40		6	18.00
41	P5-B		TP5		6	10.00
42	TPA		A1-42		6	18.00
43	P1-E		A1-43		6	23.00
44	P1-R		A1-44		6	23.00
45	P1-S		R1B-3		6	12.00
46	Q2-E		A1-E2		6	6.00
47	Q2-B		A1-E2		6	5.00
48	P5-A		TPA		6	10.00
49	P1-F		R1B-3		6	11.00
50	A2-C		A1-50		6	11.00
51	J3-D		A1-51		6	22.00
52	J3-C		A1-52		6	22.00
53	R1B-2		R1B-3		6	6.50
54	Q2-C	5	A1-C2		6	4.00
55	P1-U		A1-15		6	23.00
57	R15-1		A1-44		6	18.50
58	P2-B		A1-33		6	19.00
59	A1-7		L3-1		6	6.50
60	A1-8		L3-2		6	6.50
61	A1-61		R10-2		6	6.50

FIND NO.	SYM	CODE IDENT	DWG SIZE	PART OR IDENTIFYING NO.	QTY REQD	NOMENCLATURE OR DESCRIPTION	SPECIFICATION
1	M		B	69-502-6	1	CONN.RECEPTACLE,PN MS 3102R-108L-4P	
2	M		B	69-502-4	1	CONN.RECEPTACLE,PN MS 3102R-148-6P	
3	M		B	69-502-3	1	CONN.RECEPTACLE,PN MS 3102R-148-2B	
4	M		B	69-502-5	1	CONN.RECEPTACLE,PN MS 3102R-22-14P	
5				MS 26036-101	2	TERMINAL,LUG,CRIMP STYLE,COP. TIN PLD,INSUL,RING-TONGUE,BELL- MOUTHED,TYPE II,CL 1,22-18 TERM. SIZE,NO.6 STUD SIZE	
6	B			MS3387-1-0	AR	WIRE,ELEC,TYPE C-20,105°C,1000 V STRAP,CABLE,ADJ,SELF-CLINCHING, PLASTIC,TYPE 1,CL 1,1.8 MAX SCL DIA,NATURAL	MIL-W-16876/2
8	B			CL 1	AR	INSULATION SLEEVING,ELEC,HEAT SHRINKABLE,POLYVINYL CHLORIDE,FLEX, CROSSLINKED,.125 MIN ID,AS SUPPLIED, .082 MAX ID X .028 WALL,AFTER UNRESTRICTED SHRINKAGE,AR L	MIL-I-23063/2

  

NOTES:

- INSTALL CABLE STRAPS, FIND NO. 7, AT 1.5 INTERVALS AND AT EACH CABLE BREAKOUT.
- CRIMP STYLE TERMINALS, FIND NO. 5, SHALL BE IN ACCORDANCE WITH MIL-STD-454, REQUIREMENT 1B.
- CONDUCTOR ENDS WITHOUT TERMINALS OR CONNECTORS SHALL BE STRIPPED .25 INCH AND TINNED IN ACCORDANCE WITH MIL-STD-454, REQUIREMENT NO. 5.
- BOLDER ALL CONNECTORS IN ACCORDANCE WITH MIL-STD-454, REQUIREMENT NO. 5.
- EACH WIRE SHALL BE PERMANENTLY AND LEGIBLY IDENTIFIED AT EACH END OF THE WIRE.
- INSTALL INSULATION SLEEVING, FIND NO. 8 OVER EACH BOLDER CONNECTION TO CONNECTORS (FIND NO. 1,2,3 AND 4) AND HEAT SHRINK TO A FIRM FIT. SLEEVING SHALL EXTEND OVER WIRE INSULATION AT A MINIMUM OF .25 IN.
- REFERENCES:  
FOR ELECTRICAL WIRING DIAGRAM, SEE DRAWING 69-730  
FOR ELECTRICAL SCHEMATIC DIAGRAM, SEE DRAWING 69-729
- FOR INTERPRETATION OF:  
REFERENCE DESIGNATIONS FOR ELECTRICAL AND ELECTRONICS AND EQUIPMENTS, SEE ANS Y32.16  
DIMENSIONING AND TOLERANCING, SEE ANS Y14.5

ME 5-6115-465-34/4-16 (2)

Figure 4-16 50/60 Hz Governor Control Unit Wiring Harness, Drawing No. 69-731 (Sheet 2 of 3)

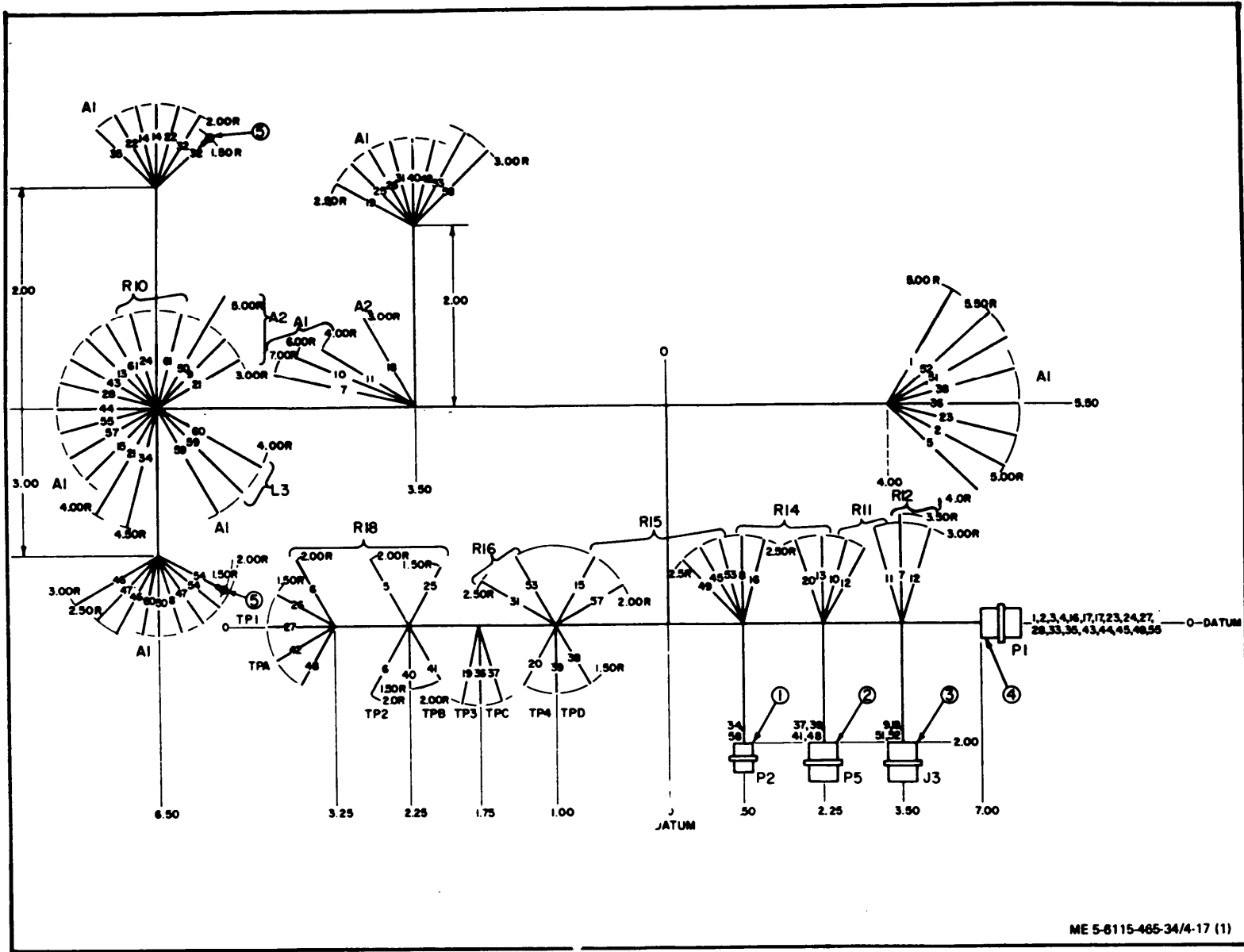

ME 5-6115-465-34/4-17 (1)

Figure 4-17. 400 Hz Governor Control Unit Wiring Harness, Drawing No. 69-814 ( Sheet 1 of 2)

WIRE NO. (REF)	FROM	TERM. FIND NO. (REF)	TO	TERM. FIND NO. (REF)	WIRE FIND NO.	WIRE CUT LENGTH (REF)
1	P1-B		A1-1		6	22.00
2	P1-A		A1-2		6	22.00
5	R18-2		A1-5		6	18.50
6	TP2		R18-1		6	8.00
7	R12-3		A1-7		6	24.00
8	R14-1		A1-8		6	20.50
9	J3-A		A2-8		6	21.90
10	R11-1		A1-10		6	20.00
11	R11-3		A1-11		6	20.00
12	R11-2		R12-1		6	7.00
13	R14-3		A1-13		6	20.00
14	Q1-E		A1-E1		6	4.90
15	R15-1		A1-15		6	18.50
16	P1-P		R14-2		6	11.00
17	P1-H		P1-J		6	2.90
18	J3-B		A2-A		6	21.00
19	TP3		A1-19		6	18.00
20	TP4		R14-2		6	8.00
21	A2-D		A1-21		6	7.80
22	Q1-B		A1-81		6	4.80
23	P1-N		A1-23		6	22.00
24	P1-T		R10-1		6	23.00
25	R18-3		A1-25		6	19.00
26	TP1		A1-26		6	20.00
27	P1-M		TP1		6	13.00
28	P1-G		A1-28		6	23.00
31	R18-2	5	A1-31		6	19.00
32	Q1-C		A1-C1		6	4.00
33	P1-C		A1-33		6	22.00
34	P2-A		A1-34		6	20.00
35	P1-D		A1-35		6	24.00
36	TPC		A1-36		6	19.00
37	P5-C		TPC		6	8.50
38	TPD		A1-38		6	18.00
39	P5-D		TPD		6	7.00
40	TP8		A1-40		6	18.00
41	P5-B		TP8		6	10.00
42	TPA		A1-42		6	18.00
43	P1-E		A1-43		6	23.00
44	P1-R		A1-44		6	23.00
44	P1-R		A1-44		6	23.00
45	P1-S		R15-3		6	12.00
46	Q2-E		A1-E2		6	6.00
47	Q2-B		A1-B2		6	5.00
48	P6-A		TPA		6	10.00
49	P1-F		R15-3		6	11.00
50	A2-C		A1-80		6	11.00
51	J3-D		A1-81		6	22.00
52	J3-C		A1-82		6	22.00
53	R15-2		R16-3		6	6.50
54	Q2-C	5	A1-C2		6	4.00
55	P1-U		A1-15		6	23.00
57	R15-1		A1-44		6	18.50
58	P2-B		A1-33		6	19.00
59	A1-7		L3-1		6	8.50
60	A1-8		L3-2		6	9.50
61	A1-61		R10-2		6	6.50

NOTES:

- INSTALL CABLE STRAPS FIND NO. 7, AT 1.5 INTERVALS AND AT EACH CABLE BREAKOUT.
- CRIMP STYLE TERMINALS, FIND NO. 5 SHALL BE IN ACCORDANCE WITH MIL-STD-484, REQUIREMENT 1B.
- CONDUCTOR ENDS WITHOUT TERMINALS OR CONNECTORS SHALL BE STRIPPED .25 INCH AND TINNED IN ACCORDANCE WITH MIL-STD-484, REQUIREMENT NO. 5.
- SOLDER ALL CONNECTORS IN ACCORDANCE WITH MIL-STD-484, REQUIREMENT NO. 5.
- EACH WIRE SHALL BE PERMANENTLY AND LEGIBLY IDENTIFIED AT EACH END OF WIRE.
- INSTALL INSULATION SLEEVING FIND NO 8 OVER EACH SOLDER CONNECTION TO CONNECTORS (FIND NO. 1,2,3, AND 4) AND HEAT SHRINK TO A FIRM FIT. SLEEVING SHALL EXTEND OVER WIRE INSULATION A MINIMUM OF .25 IN.
- REFERENCE:  
FOR ELECTRICAL WIRING DIAGRAM, SEE DRAWING 69-813  
FOR ELECTRICAL SCHEMATIC DIAGRAM, SEE DRAWING 69-812
- FOR INTERPRETATION OF:  
REFERENCE DESIGNATIONS FOR ELECTRICAL AND ELECTRONICS PARTS AND EQUIPMENTS, SEE ANS Y32.16.  
DIMENSIONING AND TOLERANCING, SEE ANS Y14.5

FIND NO'	SYM	CODE IDENT	DWG SIZE	PART OR IDENTIFYING NO.	QTY REQD	NOMENCLATURE OR DESCRIPTION	SPECIFICATION
1	M		B	69-802-6	1	CONN, RECEPTACLE, PN MS 3102R-108L-4P	
2	M		B	69-802-4	1	CONN, RECEPTACLE, PN MS 3102R-148-8P	
3	M		B	69-802-3	1	CONN, RECEPTACLE, PN MS 3102R-148-2S	
4	M		B	69-802-5	1	CONN, RECEPTACLE, PN MS 3102R-2214P	
5				MS 25036-101	2	TERMINAL, LUG, CRIMP STYLE, COP. TIN PLD, INSUL. RING-TONGUE, BELL-MOUTHED, TYPE II, CL 1, 22-18 TERM. SIZE NO. 6 STUD SIZE	
6	B			MS 3367-1-6	AR	WIRE, ELEC, TYPE C-20, 105°C, 1000 V STRAP, CABLE, ADJ, SELF-CLINCHING, PLASTIC, TYPE 1, CL 1, 1.5 MAX BDL DIA.	MIL-W-16878/2
7					AR	NATURAL INSULATION SLEEVING, ELEC, HEAT SHRINKABLE, POLYVINYL CHLORIDE, FLEX, CROSSLINKED, .125 MIN ID, AS SUPPLIED, .082 MAX ID x .026 WALL, AFTER UNRESTRICTED, SHRINKAGE, AR L	MIL-I-23083/2

ME 5-6115-465-34/4-17 (2)

Figure 4-17. 400 Hz Governor Control Unit Wiring Harness, Dwg. No. 69-814, (Sheet 2 of 2)

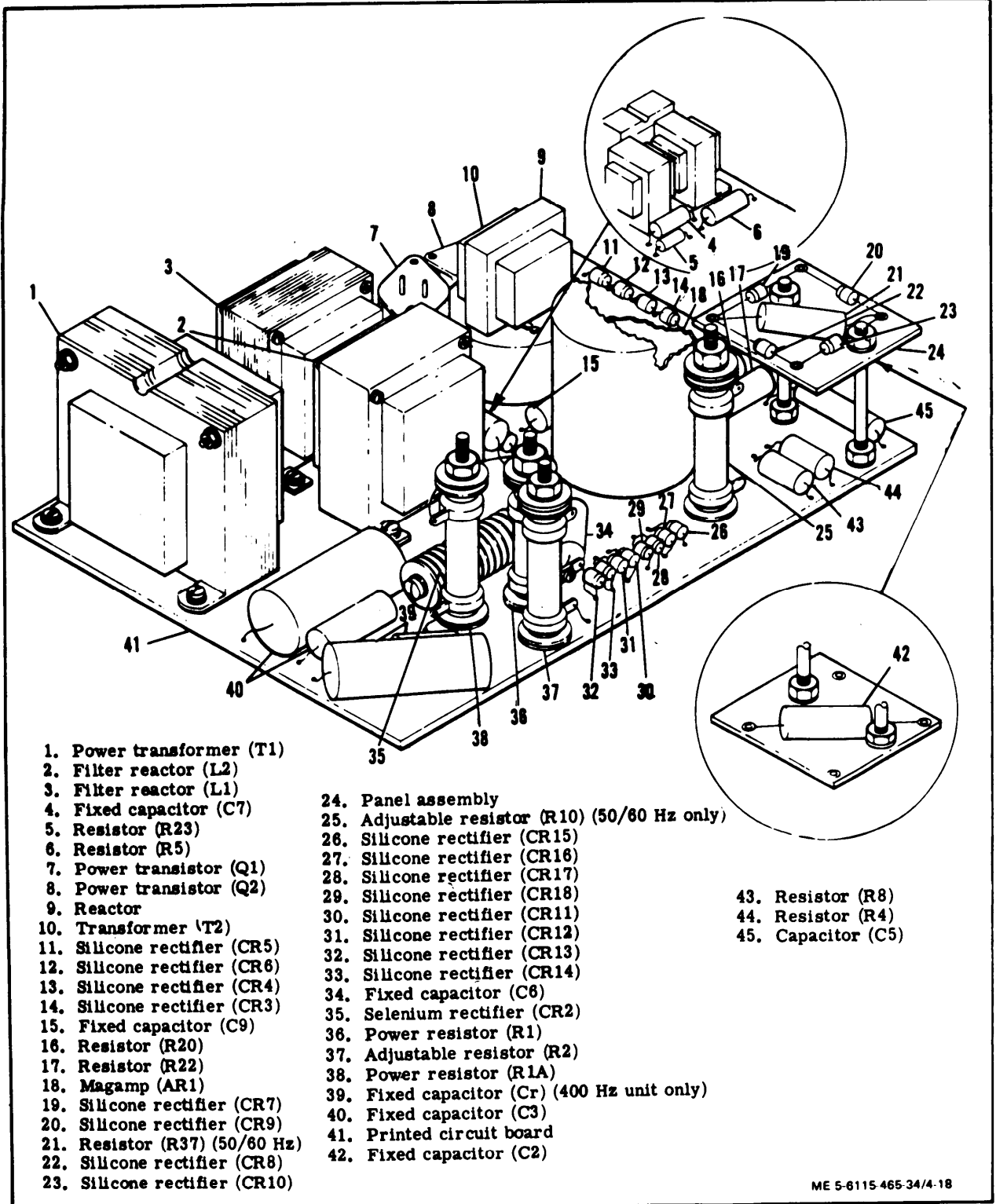

ME 5-6115-465-34/4-18

Figure 4-18. Governor Control Unit Printed Circuit Board

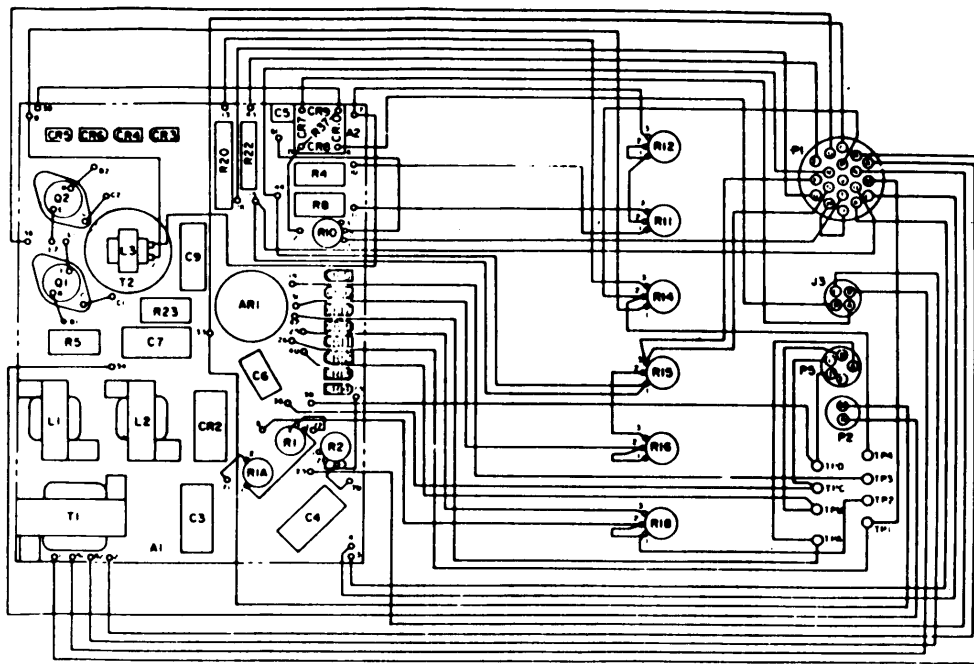

ELEC REF DESIG	DESCRIPTION	ELEC REF DESIG	DESCRIPTION
AR1	MAGAMP	R1, R1A	RESISTOR, POWER
C2	CAPACITOR, FIXED	R4, R8,	RESISTOR
C3, C4	CAPACITOR, FIXED	R22, R37	RESISTOR
C5	CAPACITOR, FIXED	R5	RESISTOR
C6	CAPACITOR, FIXED	R2, R10	RESISTOR, ADJUSTABLE
C7	CAPACITOR, FIXED	R11	RESISTOR, VARIABLE
C9	CAPACITOR, FIXED	R12	RESISTOR, VARIABLE
CR2	SELENIUM RECTIFIER	R14	RESISTOR, VARIABLE
CR3-CR18	RECTIFIER, SILICON	R15	RESISTOR, VARIABLE
J3	CONNECTOR, RECEPTACLE	R16	RESISTOR, VARIABLE
L1	FILTER REACTOR	R18	RESISTOR, VARIABLE
L2	FILTER REACTOR	R20	RESISTOR, MIL-R-26/4
L3	FILTER REACTOR	R23	RESISTOR
P1	CONNECTOR, RECEPTACLE	T1	POWER TRANSFORMER
P2	CONNECTOR, RECEPTACLE	T2	TRANSFORMER
P5	CONNECTOR, RECEPTACLE	TP1 - TP4	CONNECTOR TEST JACK
Q1, Q2	TRANSISTOR, POWER,	TPA-TPD	
A1	PRINTED WIRING BOARD ASSY		
A2	PANEL ASSEMBLY		

NOTES:

- REFERENCES:  
 FOR CONTROL UNIT ASSEMBLY, SEE DWG. 69-700  
 FOR SCHEMATIC DIAGRAM, SEE DWG 69-729  
 FOR WIRING HARNESS, SEE DWG 69-814
- FOR INTERPRETATION OF:  
 REFERENCE DESIGNATIONS FOR ELECTRICAL AND  
 ELECTRONICS PARTS AND EQUIPMENTS, SEE  
 ANS Y32.16.
- WIRE NUMBERS SHOWN ARE FOR REFERENCE ONLY:  
 A. DATA FOR WIRE NO. 1 THRU 28, 31 THRU  
 55, AND 57 THRU 61: SEE DWG 69-731.  
 B. DATA FOR WIRE NO. 29, 30 AND 56: SEE  
 DWG NO. 69-700.  
 C. DATA FOR NO. 62 THRU 66: SEE  
 DWG NO. 69-736.

ME 5-6115-465-34/4-19

Figure 4-19. 50/60 Hz Governor Control Unit Wiring Diagram, Dwg No. 69-730

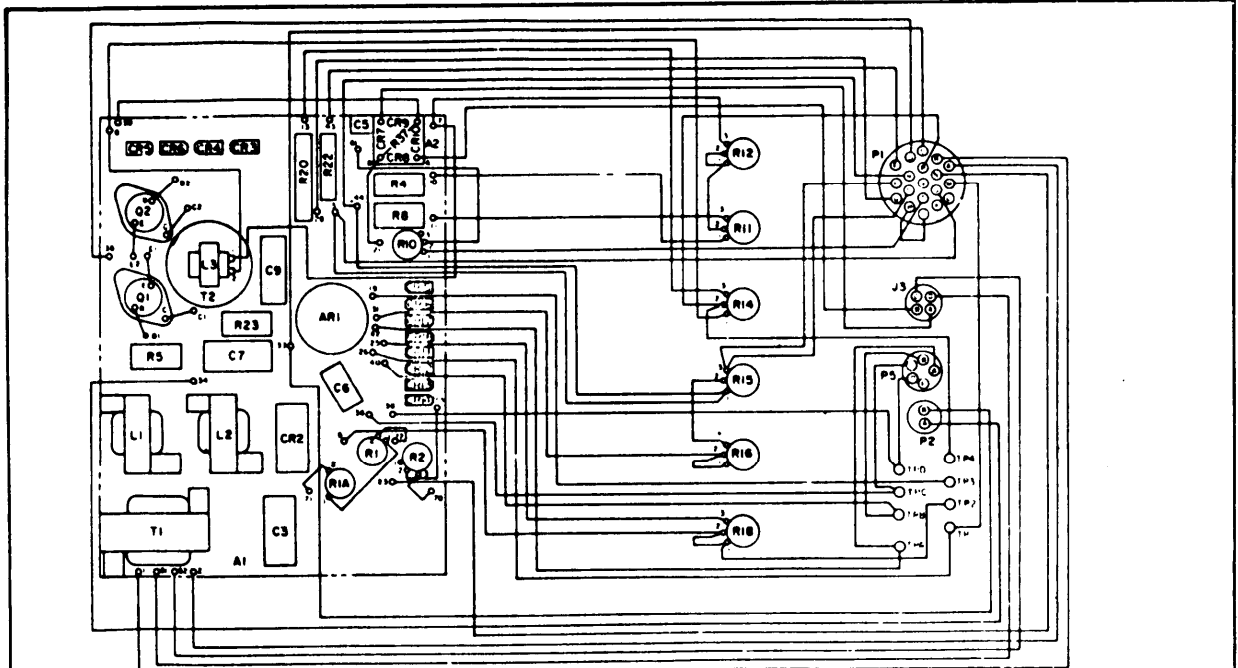

ELEC REF DESIG	DESCRIPTION	ELEC REF DESIG	DESCRIPTION
A1	PRINTED WIRING BOARD ASSY	R2, R10	RESISTOR, ADJUSTABLE
A2	PANEL ASSEMBLY	R4, R8, R22	RESISTOR
AR1	MAGAMP	R5	RESISTOR
C3	CAPACITOR, FIXED	R11	RESISTOR, VARIABLE
C5	CAPACITOR, FIXED	R12	RESISTOR, VARIABLE
C6, C9	CAPACITOR, FIXED	R14	RESISTOR, VARIABLE
C7	CAPACITOR	R15	RESISTOR, VARIABLE
CR2	SELENIUM RECTIFIER	R16	RESISTOR, VARIABLE
CR3 THRU 16	RECTIFIER SILICON	R18	RESISTOR, VARIABLE
J3	CONNECTOR, RECEPTACLE	R20	RESISTOR, MIL-R-26/4
L1	FILTER REACTOR	R23	RESISTOR
L2	FILTER REACTOR	R37	RESISTOR
L2	FILTER REACTOR	T1	POWER TRANSFORMER
L3	FILTER REACTOR	T2	TRANSFORMER
P1	CONNECTOR, RECEPTACLE	TPA THRU TPD	CONNECTOR, TEST JACK, MIL-C-39024/10
P2	CONNECTOR, RECEPTACLE	TPD	CONNECTOR, TEST JACK, MIL-C-39024/10
P5	CONNECTOR, RECEPTACLE	TP1 THRU TP4	CONNECTOR, TEST JACK, MIL-C-39024/10
Q1, Q2	TRANSISTOR, POWER, NPN, 2N3773		
R1, R1A	RESISTOR, POWER - MIL-R-26/3		

**NOTES:**

**1. REFERENCES:**

FOR CONTROL UNIT ASSEMBLY, SEE DWG 69-800  
FOR SCHEMATIC DIAGRAM SEE DWG 69-812  
FOR WIRING HARNESS, SEE DWG 69-814

**2. FOR INTERPRETATION OF:**

REFERENCE DESIGNATIONS FOR ELECTRICAL AND  
ELECTRONICS PARTS AND EQUIPMENTS, SEE  
ANS Y32-16.

**3. WIRE NUMBERS SHOWN ARE FOR REFERENCE ONLY:**

A. DATA FOR WIRE NO. 1, 2, 5 THRU 28, 31 THRU 55, AND 57  
THRU 61, SEE DWG 69-814  
B. DATA FOR WIRE NO 29, 30, AND 56, SEE DWG 69-800  
C. DATA FOR WIRE NO 62-66, SEE DWG 69-801

ME 5-6115-465-34/4-20

Figure 4-20. 400 Hz Governor Control Unit Wiring Diagram Drawing No. 69-833

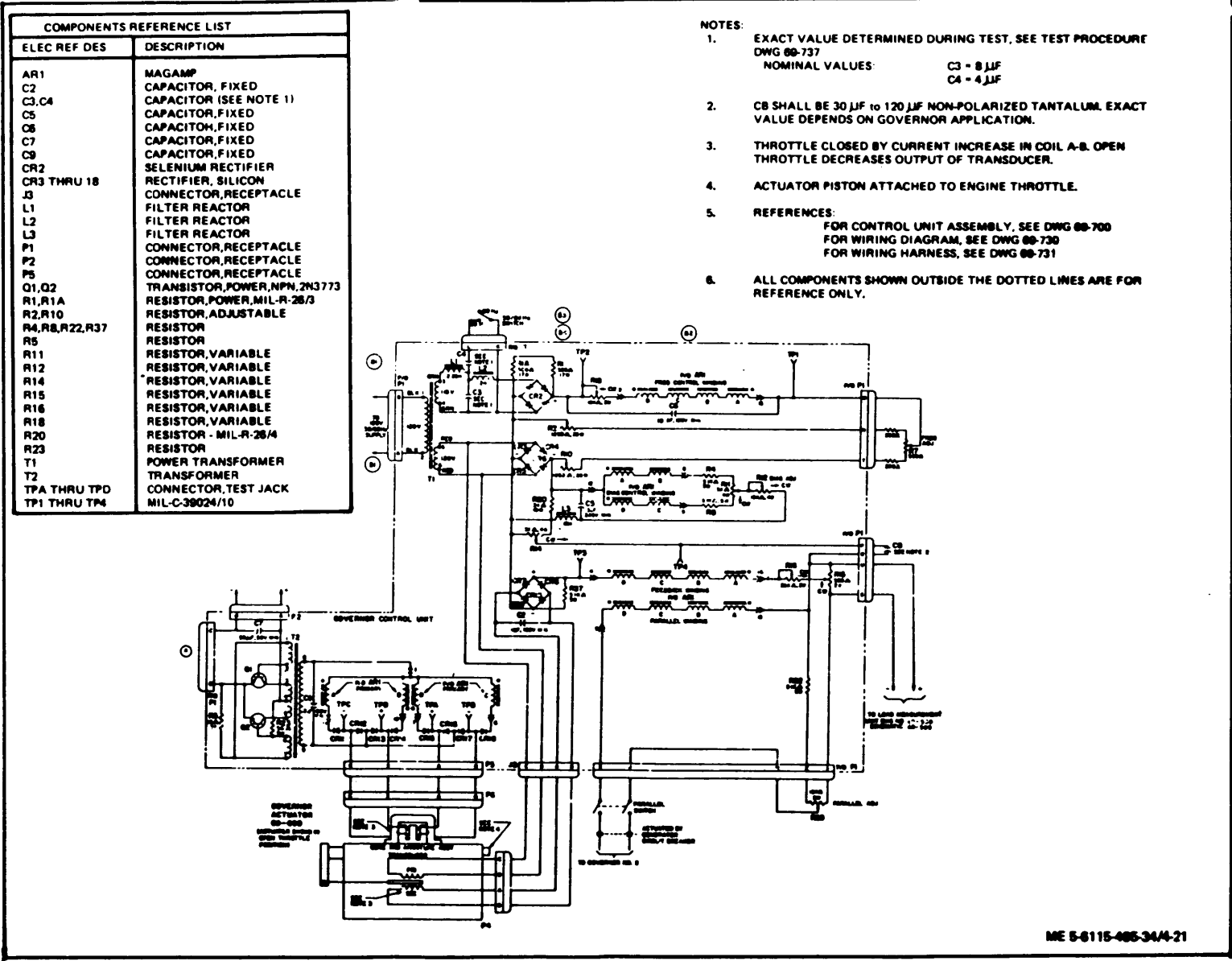

ME 5-6115-465-34/4-21

Figure 4-21. 50/60 Hz Governor Control Unit Schematic Diagram, Drawing No. 69-729



Figure 4-22. 400 Hz Governor Control Unit Schematic Diagram, Drawing No. 69-812

COMPONENTS REFERENCE LIST	
ELEC REF DES	DESCRIPTION
AR1	MAGAMP
C3	CAPACITOR (SEE NOTE 1)
C5	CAPACITOR, FIXED
C5, C6	CAPACITOR, FIXED
C7	CAPACITOR, FIXED
CR2	SELENIUM RECTIFIER
CR3 THRU 18	RECTIFIER SILICON
J5	CONNECTOR, RECEPTACLE
L1	FILTER REACTOR
L2	FILTER REACTOR
L3	FILTER REACTOR
P1	CONNECTOR, RECEPTACLE
P2	CONNECTOR, RECEPTACLE
P5	CONNECTOR, RECEPTACLE
Q1, Q2	TRANSISTOR, POWER, NPN, 2N3773
R1, R1A	RESISTOR, POWER, MIL-R-26/3
R2, R10	RESISTOR, ADJUSTABLE
R4, R8, R22	RESISTOR
R6	RESISTOR
R11	RESISTOR, VARIABLE
R12	RESISTOR, VARIABLE
R14	RESISTOR, VARIABLE
R16	RESISTOR, VARIABLE
R18	RESISTOR, VARIABLE
R20	RESISTOR - MIL-R-26/4
R23	RESISTOR
R37	RESISTOR
T1	POWER TRANSFORMER
T2	TRANSFORMER
TPA THRU TPD	CONNECTOR, TEST JACK
TP1 THRU TP4	MIL-C-39024/10

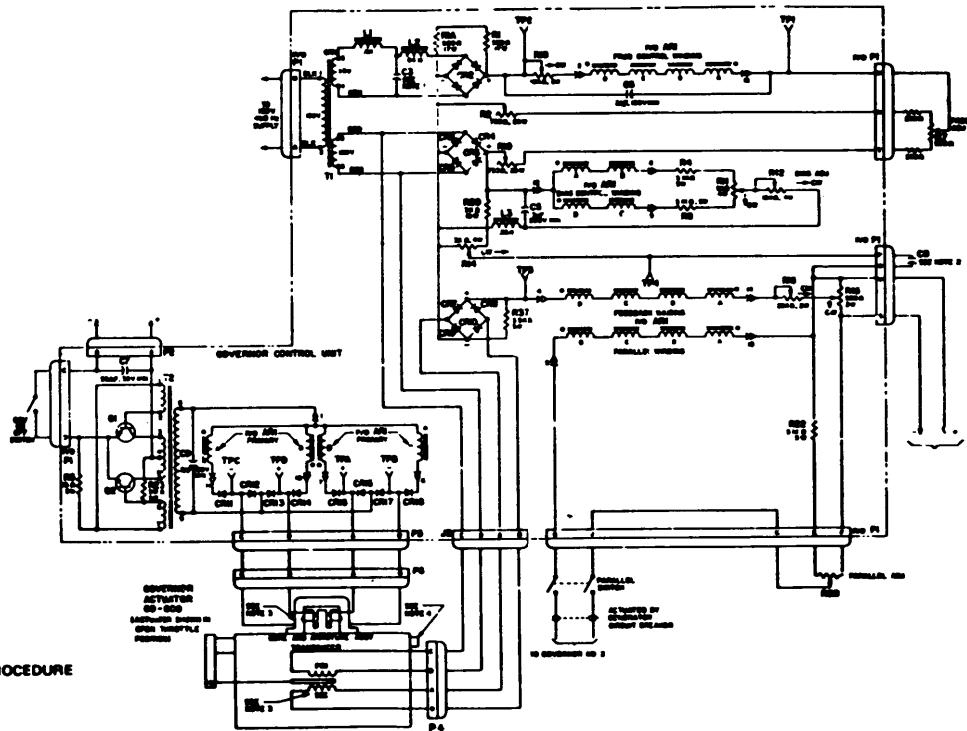

NOTES:

- EXACT VALUE DETERMINED DURING TEST, SEE TEST PROCEDURE DWG 69-815  
NOMINAL VALUES: C3 = 8μF
- C5 SHALL BE 30μF to 120 μF NON-POLARIZED TANTALUM. EXACT VALUE DEPENDS ON GOVERNOR APPLICATION.
- THROTTLE CLOSED BY CURRENT INCREASE IN COIL A-B, OPEN THROTTLE DECREASES OUTPUT OF TRANSDUCER.
- ACTUATOR PISTON ATTACHED TO ENGINE THROTTLE.
- REFERENCES:  
FOR CONTROL UNIT ASSEMBLY, SEE DWG 69-800  
FOR WIRING DIAGRAM, SEE DWG 69-813  
FOR WIRING HARNESS, SEE DWG 69-814
- FOR INTERPRETATION OF:  
REFERENCE DESIGNATIONS FOR ELECTRICAL AND ELECTRONICS PARTS AND EQUIPMENTS, SEE ANS Y32.16  
GRAPHIC SYMBOLS FOR ELECTRICAL AND ELECTRONICS DIAGRAMS, SEE ANS Y32.2
- ALL COMPONENTS SHOWN OUTSIDE THE DOTTED LINES ARE FOR REFERENCE ONLY.

ME 5-6115-465-34/4-22

TM 5-6115-465-34  
TO 35C2-3-446-2  
NAVFAC P-8-625-34  
TM06858B/06859D-34

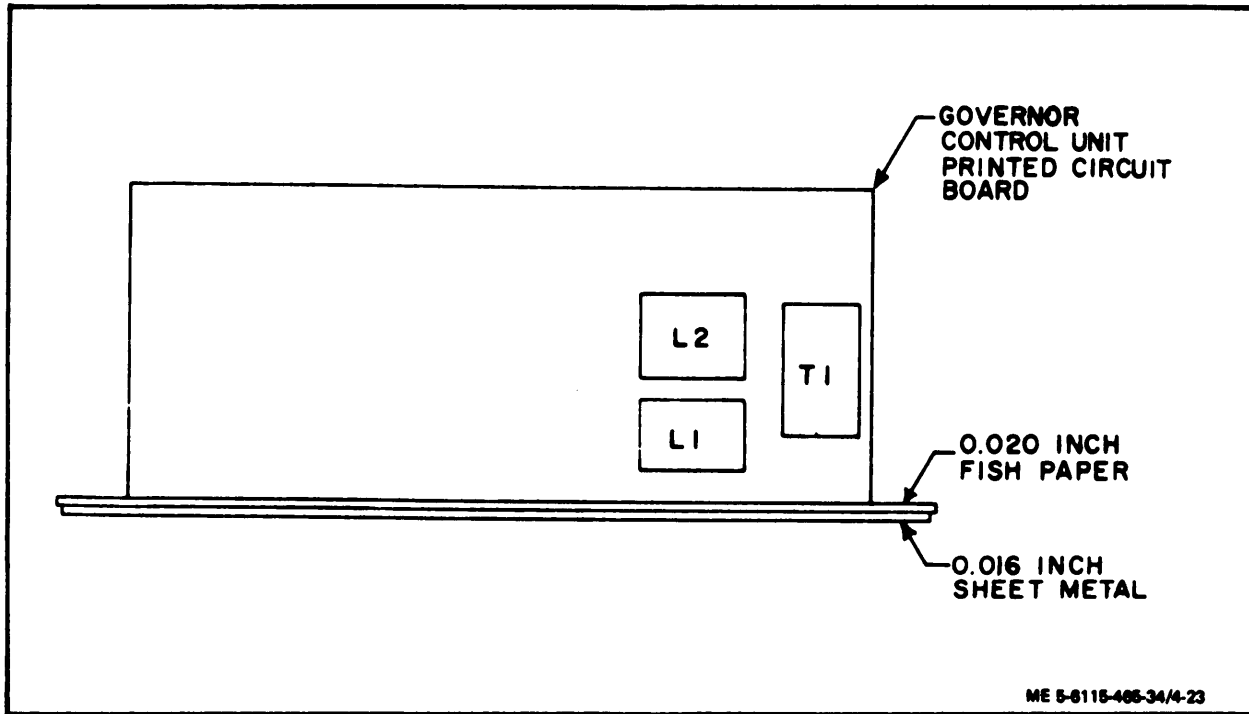

Figure 4-23. Positioning of Unpotted Governor Control Unit During Testing

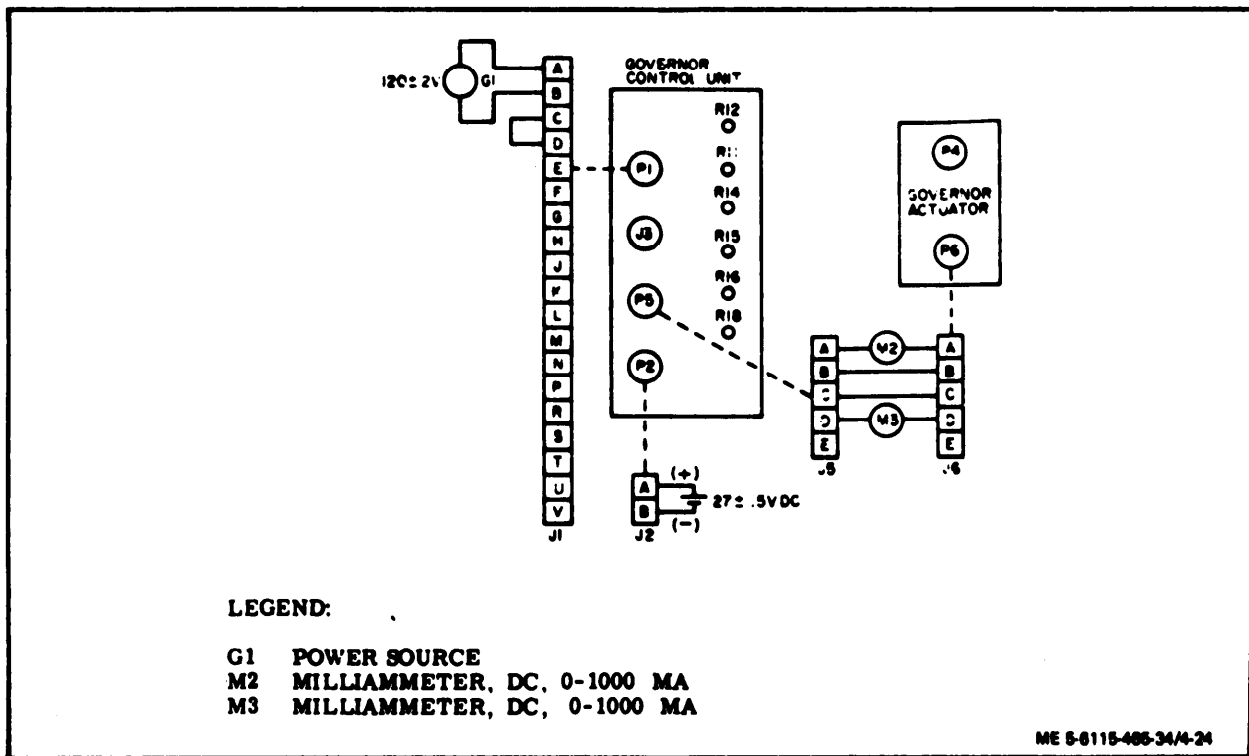

Figure 4-24. Governor Control Unit Magnetic Amplifier Bias Test Circuit

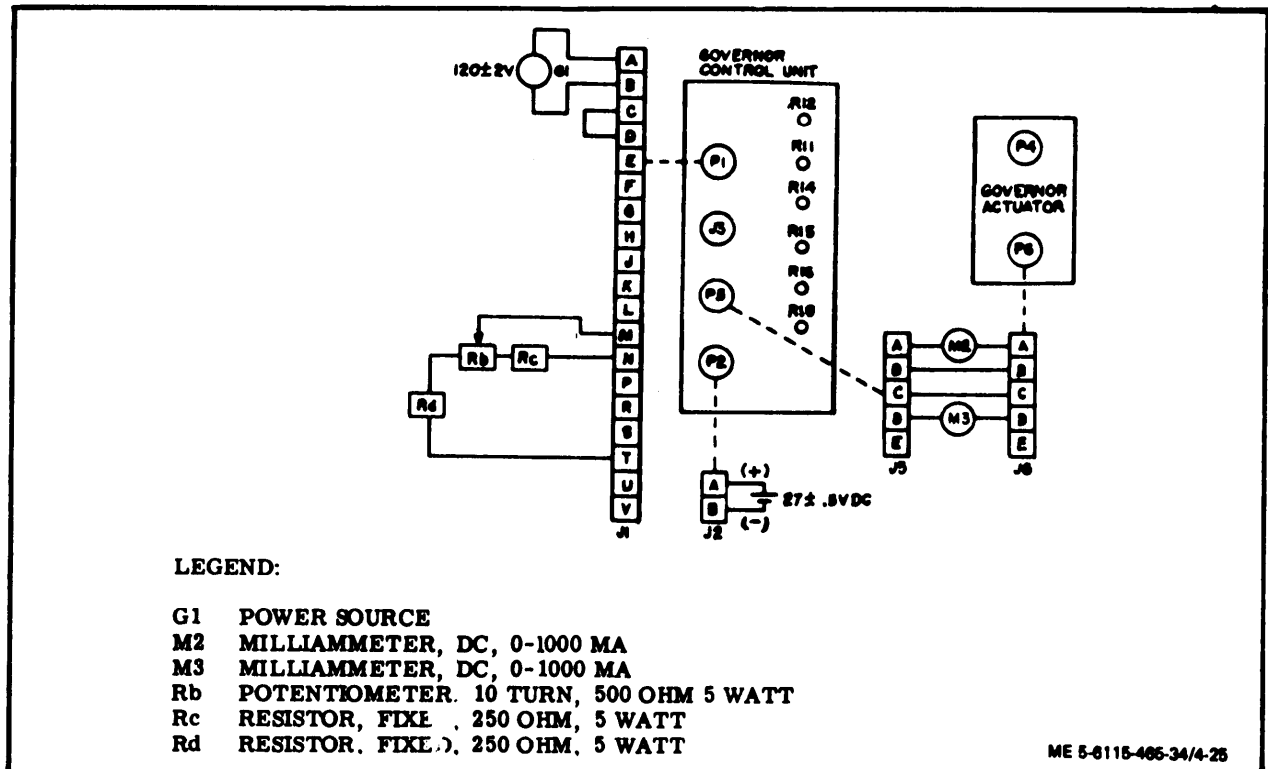

Figure 4-25. Governor Control Unit Frequency Sensing Test Circuit

- (a) Install governor control unit in test circuit as shown in figure 4-28.
- (b) Turn R14 and R15 to full counterclockwise position.
- (c) M5 shall indicate -5 to -7 milliamperes.
- (d) Adjust R14 clockwise until indication and M2 and M3 are balanced.
- (e) Place SW1 in the LOW position M3 shall indicate 600 to 840 milliamperes. M3 shall indicate 0 to 300 milliamperes. M5 shall indicate less than 0 to +1.5 milliamperes.
- (f) Place SW1 in the HIGH position M3 shall indicate 0 to 300 milliamperes. M3 shall indicate 600 to 840 milliamperes. M5 shall indicate less than 0 to -1.5 milliamperes.
- (6) Perform parallel winding test as follows:
  - (a) Install governor control unit in test circuit as shown in figure 4-27.
  - (b) M2 shall indicate 0 to 300 milliamperes. M3 shall indicate 600 to 840 milliamperes.
  - (c) Reverse polarity of connections to pins J1-E and J1-G.
  - (d) M2 shall indicate 600 to 840 milliamperes. M3 shall indicate 0 to 300 milliamperes.
  - h. Potting.
    - (1) Check all connections and if any have been bored for test purposes, or if any defective components have been replaced, the effected area and components must be coated with polyurethane resin to prevent oxidation or other corrosion. The coating must be of a minimum thickness of 0.007 inch and air bubble entry so the applied polyurethane must be controlled so that the legibility of component coding and identification is not impaired.
    - (2) Check connections of printed circuit board to cover.
    - (3) Place the container in a temperature controlled oven. Set the oven temperature at +180 to +185° F (+82.2 C° to + 85° C) and allow the container to soak 11 to 12 hours or until potting compound is completely melted.
    - (4) Prior to installing the printed circuit board, remove the container from the oven and make sure that insulation paper is positioned next to the container shell,

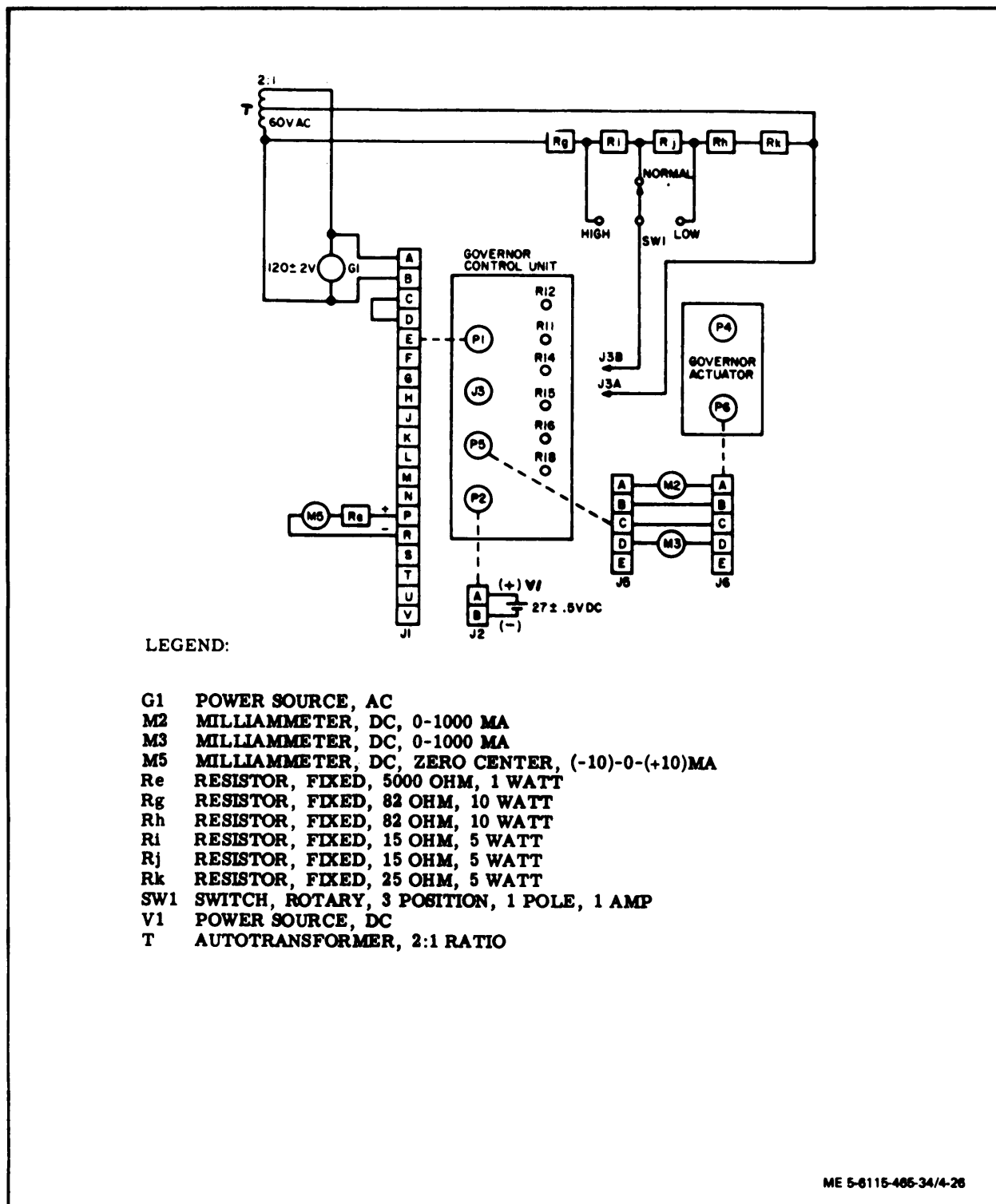
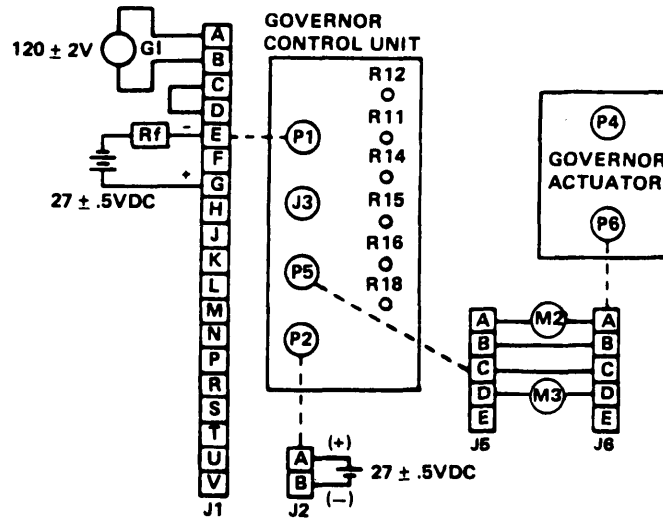

Figure 4-26. Governor Control Unit Rectifier Bridge and Feedback Winding Test Circuit



**LEGEND:**

- G1: POWER SOURCE**
- M2 MILLIAMMETER, DC, 0-1000 MA**
- M3 MILLIAMMETER, DC, 0-1000 MA**
- Rf RESISTOR, FIXED, 50,000 OHM, 1 WATT**

ME 5-6115-465-34/4-27

Figure 4-27. Governor Control Unit Parallel Winding Test Circuit

(5) Using heavy gloves and safety glasses, slowly lower the printed circuit board into the potting compound.

**WARNING**

Use care not to splash hot potting compound on operating personnel. It can cause severe injury.

(6) Position the printed circuit board and allow compound to cool.

(7) When compound has cooled and is substantially solid, install top cover and hardware.

i. Installation. Install governor control unit in reverse order of removal procedures. Refer to figure 4-28 for approximate position of controls when connecting linkage.

**NOTE**

Desired speeds must be obtained by trial and error adjustments of linkage, position of control arm and performing the alignment procedures in paragraph 4-7j.

j. Alignment Procedure. See figure 4-29 for identification of controls and perform the following procedures.

(1) Set R11, R14, R16 and R18 rheostats at mid-point.

(2) Set R15 full counterclockwise.

(3) Set R12 approximately 3/4 turn counterclockwise.

(4) Refer to Organizational Maintenance Manual and start engine. If engine oscillates rapidly, adjust R16 and R18 until operation is stable.

(5) Once set has been stabilized, adjust R1 rheostat on control panel to obtain 60 Hz.

(6) Connects dc voltmeter with 0-10 volt range across test points 3 and 4, Test point 4 is positive. Adjust R14 until voltage across test points 3 and 4 is zero at no load.

(7) Connect dc voltmeter across test points 1 and 2. Test point 1 is positive. Adjust R11 for zero volts at 60 Hz at no load. Repeat adjustment until voltage across test points 1 and 2 and 3 and 4 is zero and frequency is 60 Hz.

**NOTE**

If test points 1 and 2 cannot be zeroed, they must be reduced to a minimum.

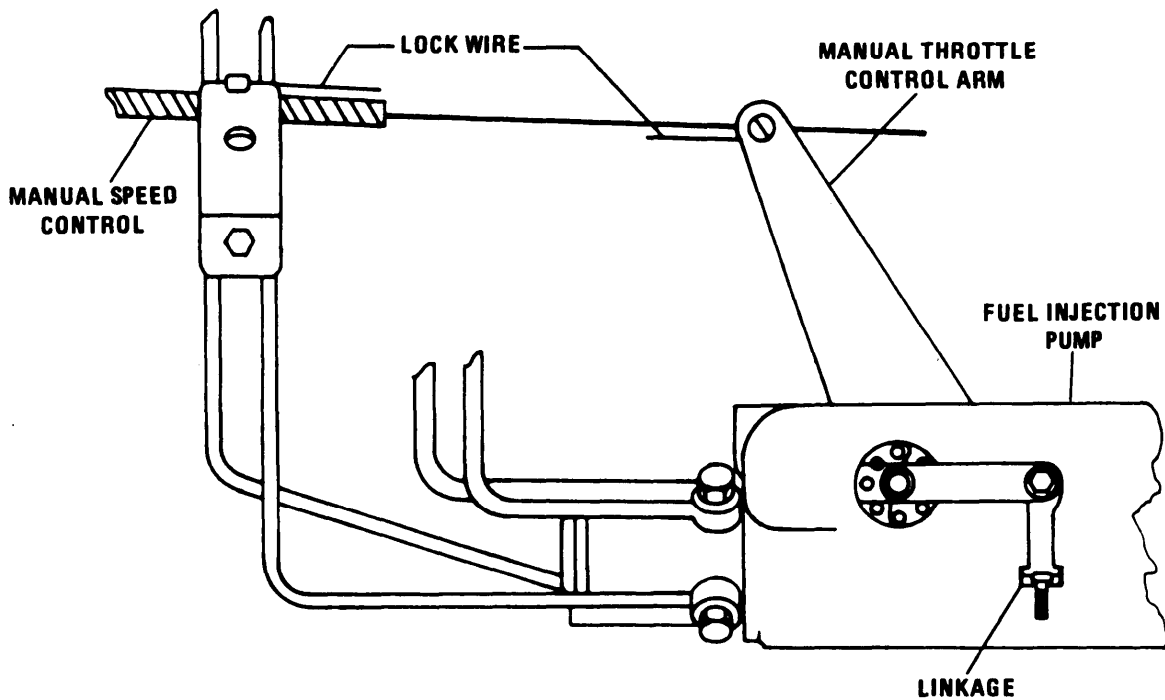

Figure 4-28. Approximate Position Of Controls For Connecting Actuator

(8) Adjust R12 to give approximately 5 volts across test points A and B.

(9) Adjust R15 for optimum transient performance. Fully clockwise position is maximum load measurement gain.

(10) Set R18 and R16 for stabilized performance at all load conditions. For optimum performance R18 should be set as far counterclockwise as possible without causing an oscillation for any setting of R15.

(11) Increasing the load measurement gain R15 (turning in a clockwise direction) will improve transient performance; therefore, it should be adjusted as high as possible. The adjustment of R18, R16, and R15 are interdependent. For any position of R18, there is an optimum position for R16. Therefore, to improve transient performance, increase the frequency gain by turning R18 clockwise. If a hunt develops, readjust R16 for stability. If no hunt develops, apply and reject load to check for stability under transient conditions.

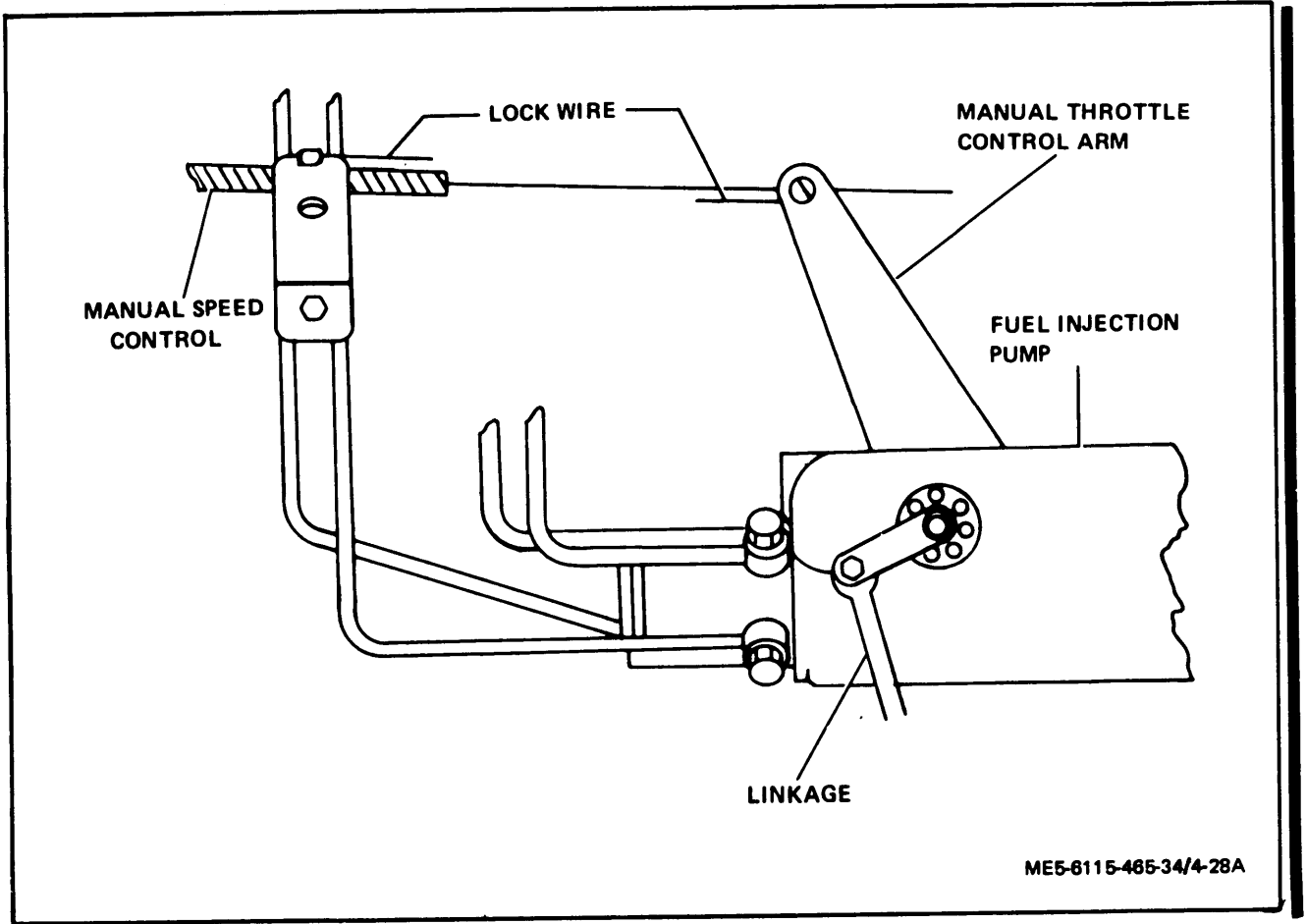

Figure 4-28.1. Approximate Position of Controls for Connecting Actuator (Effective with Serial No. RZ70001 and KZ00001 thru KZ02752)





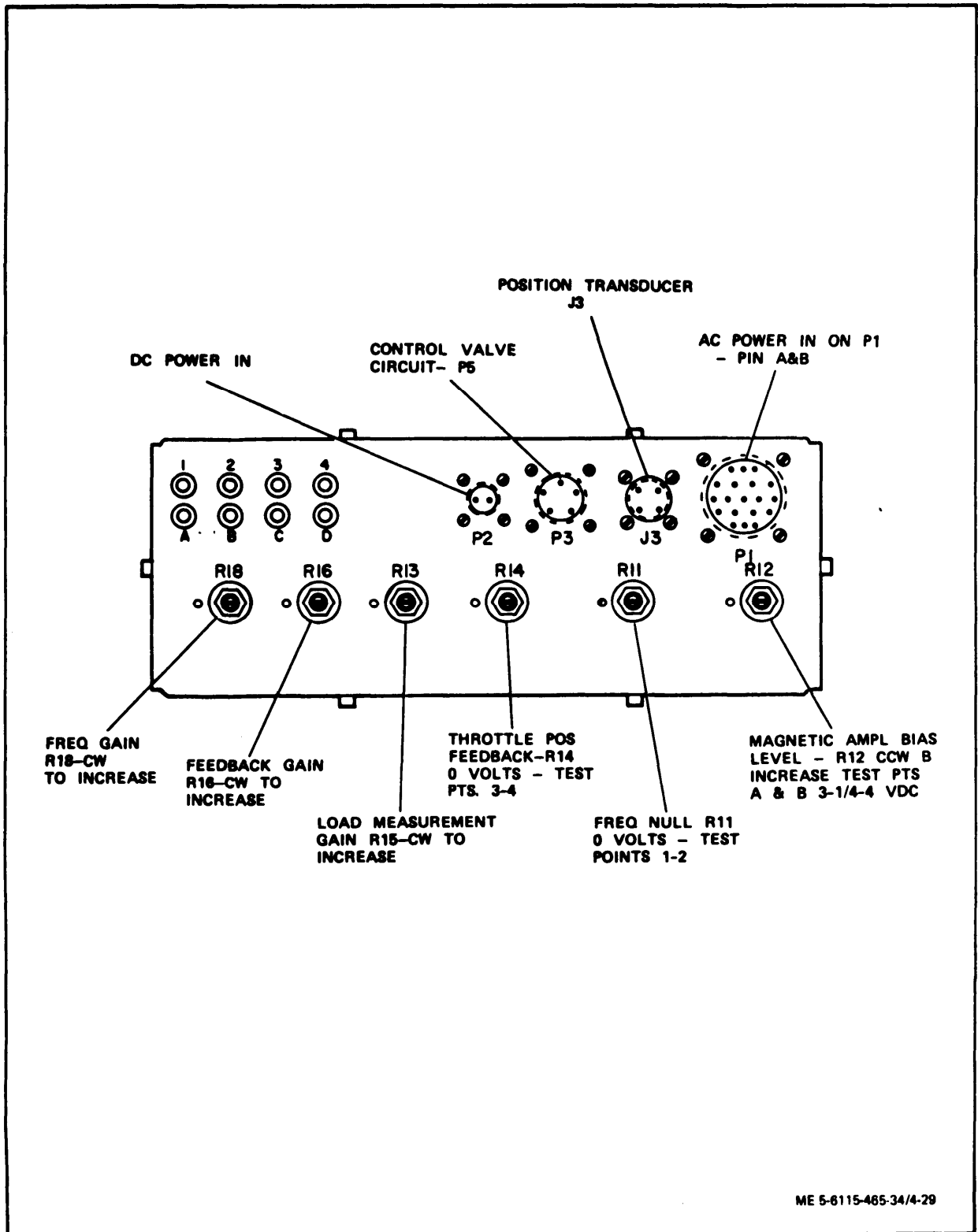
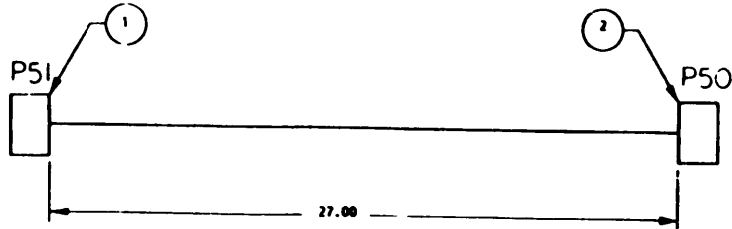

Figure 4-29. Governor Control Unit Control Panel



NOTES:

1. ALL SOLDERED CONNECTIONS SHALL BE IN ACCORDANCE WITH MIL-STD-464, REQUIREMENT 5.
2. INSTALL STRAPS, FIND NO. 4 AT 3.0 MAX. INTERVALS.
3. WIRE MARKING TO BE IN ACCORDANCE WITH MIL-W-508B EXCEPT THAT LENGTH BETWEEN GROUPS OF NUMBERS SHALL NOT EXCEED 8 INCHES.
4. INSTALL END SEAL PLUGS, FIND NO. 5 ON UNUSED HOLES OF CONNECTORS FIND NO. 1 AND 2.
5. INTERPRET DRAWING PER MIL-STD-100.

6. REFERENCES:

- a) FOR WIRING DIAGRAM, SEE DRAWING 72-2205
- b) FOR SCHEMATIC DIAGRAM, SEE DRAWING 72-2286 AND 72-2277.

MARKING	WIRE COLOR	WIRE MARKING	TERMINATION		WIRE FIND NO.	WIRE LENGTH REF.
			FROM FIND NO. REF.	TO FIND NO. REF.		
	BLACK	D24J16	P50-d	P51-d	3	28.00
	BLACK	K101D16	P50-X	P51-X	3	
	BLACK	K102D16	P50-H	P51-H	3	
	RED	P50CC16	P50-L	P51-L	3	
		P50PP16	P50-B	P51-B	3	
		P55AH16	P50-W	P51-W	3	
		P55IR16	P50-P	P51-R	3	
		P50A16	P50-A	P51-A	3	
		P60E16	P50-E	P51-E	3	
		P62G16	P50-H	P51-H	3	
		P62D16	P50-b	P51-b	3	
		P62B16	P50-a	P51-a	3	
		P200M16	P50-P	P51-P	3	
		P203C16	P50-F	P51-F	3	
		P205C16	P50-D	P51-D	3	
		P206C16	P50-C	P51-C	3	
		P209C16	P50-G	P51-G	3	
	BLACK	X7F16A	P50-S	P51-S	3	
		X8F16B	P50-R	P51-R	3	
		X9H16C	P50-J	P51-J	3	
		X12T16M	P50-K	P51-K	3	
		X17A16	P50-T	P51-T	3	
		X18A16	P50-U	P51-U	3	
	BLACK	X19A16	P50-V	P51-V	3	28.00

FIND NO	SYM	CODE	DWG IDENT	SIZE	PART OR IDENTIFYING NO	QTY	REQD	NOMENCLATURE OR DESCRIPTION	SPECIFICATION	MATERIAL
5					MS25251-16	2		PLUG, END SEAL, ELECT. CONNECTOR		
4					MS3367-5	8		STRAP, CABLE, ADJUSTABLE		
3					MS086/2-16-9	AR		WIRE, ELECT., 16 AWG	MIL-W-5086/2	
2					MS3106R20-12P	1		CONNECTOR, PLUG, ELECT., P50		
1					MS3106R20-12S	1		CONNECTOR, PLUG, ELECT., P51		

LIST OF MATERIAL

Figure 4-30. Tactical Relay Assembly to Special Relay Assembly Wiring Harness, Drawing No. 72-2224

4-7.1 GOVERNOR CONTROL UNIT (MEP-114A).

a. General.

(1) The electric governing system is a speed (frequency) sensing system used to maintain constant engine speed and generator output frequency during periods of unchanging load and when load additions or deletions occur. The system consists of a control unit, magnetic pickup and an electric throttle actuating unit. The engine speed signal is obtained from a magnetic pickup mounted in the flywheel housing in close proximity to the flywheel ring gear. The frequency of the pickup signal is proportional to engine speed. Figure 4-30.1 shows the functional theory of operation.

(2) The control unit has four distinct circuits; pickup signal amplifier, frequency reference oscillator, phase comparator and output circuit.

(a) The Frequency Reference Oscillator is voltage controlled. The frequency setting is adjusted by applying zero to 10 volts at the Frequency Reference Oscillator input. The internal frequency adjust provides this voltage setting when the control unit is in operation. The Reference Oscillator does not maintain a constant frequency. It deviates from its nominal frequency as the engine speed changes during load changes. The Reference Oscillator is forced by the Phase Comparator to track the amplified pickup signal representing engine speed. The voltage representing speed error is the amount of voltage required to drive the Reference Oscillator off frequency in proportion to the engine speed deviation.

(b) The Phase Comparator Circuit receives signals from the Pickup Signal Amplifier and the Reference Frequency Oscillator and compares the difference in frequency. The Phase Comparator measures the amount the engine signal is ahead or behind the Reference Oscillator signal. Its voltage output is used to force the Reference Oscillator to the same frequency as the signal from the engine. The Phase Comparator output is proportional to the speed error. The gain control is used to couple the Phase Comparator output to the Reference Oscillator. By increasing the coupling, a small voltage change from the Phase Comparator represents a large frequency change and vice-versa.

(c) The Output Circuit allows governing by introducing a temporary drop during a load change for stability purposes. It has an adjustable means to control the magnitude and time constant of the drop to match the dynamic characteristics of the engine. The output current switching portion of the circuit provides current to drive the actuator. The output transistor is switched on and off at a frequency of 200 Hz. This is above the natural frequency of the actuator. The actuator responds

to the average current from the transistor and moves in proportion to position the engine throttle. The output transistor is switched on-and off to reduce power dissipation.

b. Malfunction.

The following procedures are to be performed with the Governor Control Unit in the generator set.

(1) Connect the breakout cable between wiring harness plug P17 (1, figure 4-30.2) and the electric governor.

(2) Using a digital voltmeter, make the voltage readings in table 4-4 at the breakout cable plug. All readings are measured between the terminal and ground. Terminals F, G, H and T are ground.

c. Removal.

(1) Disconnect electrical connector P17 (1, figure 4-30.2).

(2) Remove 4 hex head screws (2), lock washers (3) and nuts (4).

(3) Remove the control unit.

d. Installation.

Install the Governor Control Unit in reverse order of removal procedures.

e. Adjustment Procedure.

(1) Disconnect the actuator linkage rod from the engine fuel shutoff lever.

(2) Place the generator set START-RUN-STOP switch (located on the generator set control panel) in the RUN position.

(3) Place the generator set BATTLE SHORT SWITCH (located on the generator set control panel) in the ON (override) position.

(4) Beginning at the fully counterclockwise position, rotate the engine fuel shutoff lever in a clockwise direction until a slight resistance is felt; hold the lever in this position.

NOTE

This resistance is the fuel injection pump's internal governor linkage hook engaging the metering valve arm.

(5) Move the actuator lever to the "full fuel" position. This is the direction against the spring resistance (fully counterclockwise).

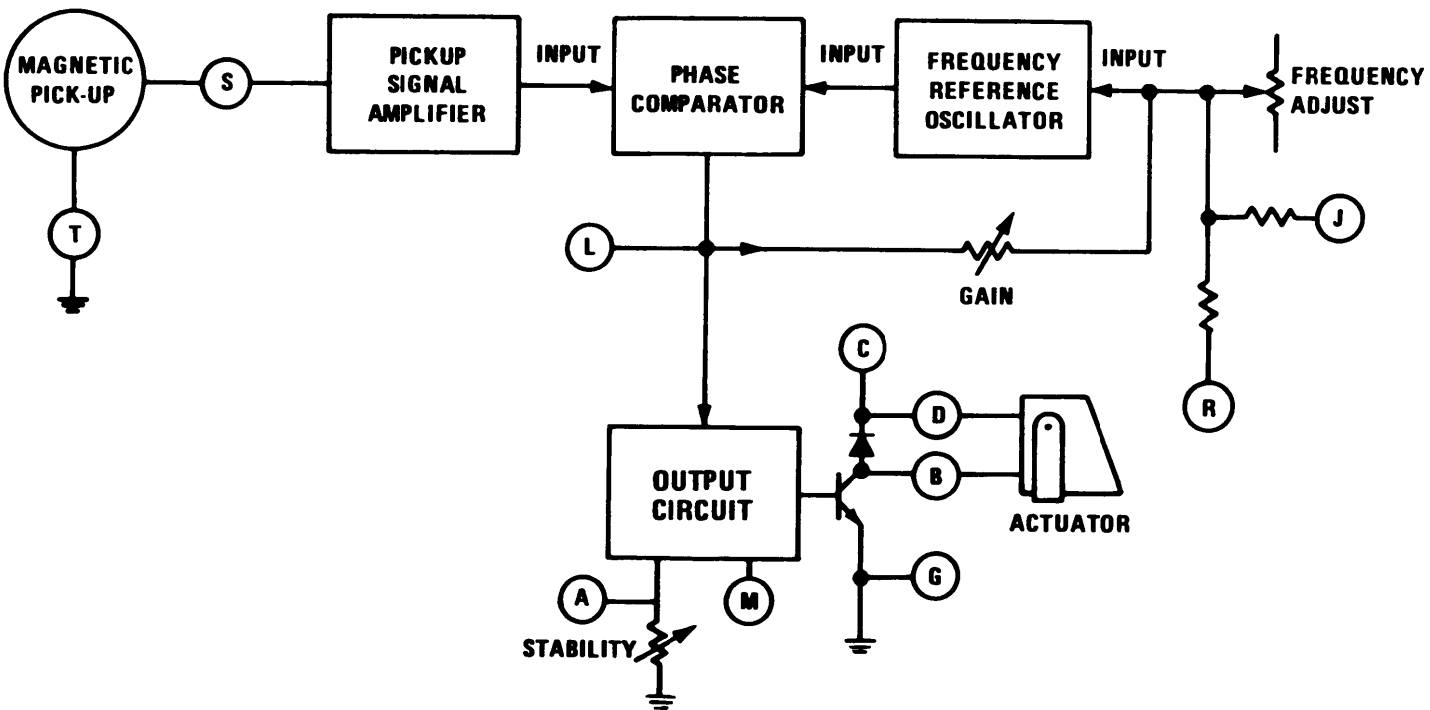

Figure 4-30.1. Functional Theory of Operation

Table 4-4. Governor Malfunction Testing

TERMINAL	NORMAL VALUE	PROBABLE CAUSE OF NON-NORMAL READING	CORRECTIVE ACTION
S	1.0 volt AC-RMS minimum while cranking.	1. Defective magnetic pickup. 2. Gap too large between magnetic pickup and gear teeth. 3. Improper or defective wiring to the magnetic pickup.	1. Replace magnetic pickup. 2. Readjust magnetic pickup. 3. Replace wiring harness.
K	10.1 ± .20 volts DC while energized (Internal regulated D.C. Supply).	1. D.C. power not connected or low battery voltage. 2. Frequency trim potentiometer shorted, grounded or miswired. 3. Wiring error. 4. Defective control unit.	1. Connect D.C. power supply; replace D.C. battery. 2. Replace Control Unit. 3. Replace wiring harness. 4. Replace control unit.
L	Above 5.1 volts D.C. while running. (inverse speed error signal ). Above 5.1 volts is under speed signal. Below 5.1 volts is over speed signal. On speed will indicate a steady 5.1 volts.	1. Frequency adjust set too low. 2. Defective control unit.	1. Turn Frequency adjust screw clockwise. 2. Replace control unit.
N	8.5 to 9.5 volts D.C. while cranking. (Proportional actuator voltage ).	1. Battery voltage may be too low while cranking, 2. Defective Control Unit.	1. Charge D.C. battery; replace D.C. battery. 2. Replace Control Unit.
R	2.5 volts D.C. maximum while cranking. (Transistor voltage).	1. Output transistor open (defective Control Unit). 2. Defective Actuator. 3. Error in wiring to Actuator.	1. Replace Control Unit. 2. Replace Actuator. 3. Replace Wiring Harness.

(6) Measure the center to center distance between the hole in the fuel shutoff lever and the hole in the actuator lever. Adjust the rod ends on the threaded linkage rod so that the center to center distance of the rod ends is the same or slightly longer than that measured between the fuel shutoff lever and the actuator lever. (The 3.75 dimension is only approximate. If the linkage is too short, the actuator lever will attain the "no fuel" position [full clockwise ] before the fuel shutoff lever reaches its "no fuel" position; the fuel shutoff lever will never reach "no fuel". If the linkage is too long, the actuator lever will reach its "full fuel" position [full counterclockwise ] before the fuel shutoff lever reaches its "full fuel" position; full load will not be reached. ) It may be necessary to readjust the position of the fuel shutoff lever and/or the actuator lever to accommodate the center to center distance of the rod ends and to assure complete fuel shutoff and full load operation. Fuel shutoff and actuator lever adjustments will be covered under replacement procedures. Tighten the nuts on the linkage rod against the rod ends to maintain proper spacing.

(7) Return the generator set START-RUN-STOP switch to the STOP position and the BATTLE SHORT switch to the OFF position.

(8) Reconnect the actuator linkage rod end to the engine fuel shutoff lever.

(9) Adjust the control unit gain control to its approximate mid-range position.

(10) Adjust the control unit stability control to its fully counterclockwise position.

(11) Adjust the generator set frequency adjust potentiometer (pot) (located on the generator set control panel ) to mid-range.

(12) Using a small screwdriver, turn the 22 turn frequency adjust potentiometer on the control unit (located on the left side vertical face of the control unit) counterclockwise (opposite increase arrow) to obtain the lowest possible reference oscillator frequency. This will give the lowest possible engine governed speed.

NOTE

Two people will be required to adjust the control unit. Ensure that the actuator linkage rod and all levers are securely fastened and move freely (without binding) before operating the engine. Manually overcome the actuator until adjustment of the control unit will be made with the engine operating in a no-load condition.

(13) Start the engine, manually operating the fuel shutoff lever.

(14) Turn the control unit frequency adjust screw clockwise until the proper engine speed is obtained. Several turns may be required. The generator set frequency adjust pot should now have sufficient adjustment travel to cause the generator set frequency meter to indicate beyond both of its extreme limits (388-412 Hz).

(15) If the engine is unstable as indicated by continuous movement of the actuator lever, turn the control unit gain control counterclockwise until stability is obtained as indicated by a stationary actuator lever. Readjust the control unit frequency adjust screw to the proper engine speed.

(16) Turn the control unit gain control clockwise until the engine becomes just unstable; back the gain control counterclockwise until the engine is again stable.

(17) Turn the control unit stability control clockwise until the engine becomes just unstable; back the stability control counterclockwise until the engine is again stable.

NOTE

The governor is now set to a nominally good operating point.

(18) Adjust control unit gain, stability and frequency under various load conditions and load changes to obtain the desired governing characteristics.

(19) When the electric governor system is properly adjusted, the locknuts on the control unit gain and stability controls should be tightened.

4-7.2 ACTUATOR UNIT.

a. Removal.

(1) Disconnect electrical connector P22, (1, figure 4-30.3).

(2) Disconnect the actuator lever from the actuator linkage rod by removing the hex head cap screw (2), flatwasher (3), and the self-locking nut (4).

NOTE

It may be necessary to remove the actuator bracket to gain access to the hardware securing the actuator to the actuator bracket. If this is not necessary, proceed to paragraph (3). If removal is required, then proceed as follows:

(a) Loosen the drive belt of the engine alternator.

(b) Remove the two hex head screws (5) and lock washers (6) securing the actuator bracket, through spacers (7), to the engine through the alternator mounting bracket.

(3) Disconnect the actuator from the actuator bracket by removing two hex head screws (8), flatwashers (9), lockwashers (10) and nuts (11). Remove the actuator.

b. Testing.

(1) Using an ohmmeter, check for continuity between pins A and B and pins C and D. Replace actuator if there is no continuity.

(2) Check for short circuit between each pin on the connector and the housing. Replace actuator if any pin is shorted to case.

b. Testing.

(1) Using an ohmmeter, test for continuity between pins A and B on the connector.

(2) If the circuit is open discard the magnetic pickup.

c. Installation

(1) Rotate the engine until the top land of one gear tooth is in line with the center of the threaded hole in the flywheel housing.

(2) Replace the magnetic pickup (3) into the threaded hole in the flywheel housing until the tip contacts the top of the gear tooth. Back the magnetic pickup out one-half to three-quarter turn and secure with the locknut (5) provided.

(3) Connect electrical connector P23 (1).

c. Installation.

(1) Position the actuator lever (12, figure 4-30.3) roughly horizontal by loosening the nut on the splined shaft end of the actuator lever, rotating the lever and tightening the nut.

(2) Align the actuator with the two holes in the actuator bracket, secure the actuator to the actuator bracket with two 3/4-inch long hex head screws (8), flatwashers (9), lock washers (10) and nuts (11).

NOTE

If the actuator bracket has not been removed, proceed with paragraph (3). If the bracket must be installed, proceed as follows:

(a) Insert the spacers (7) through the alternator mounting bracket.

(b) Secure the actuator bracket to the engine by inserting the two 1 1/2-inch long hex head screws (5), lockwashers (6), into the appropriate holes in the actuator bracket, through the spacers (7) and into the threaded holes in the engine; tighten the two screws.

(c) Adjust the drive belt of the engine alternator to the required tension and secure the alternator.

(3) Attach the actuator lever to the actuator linkage rod with the 1 1/4-inch long hex head cap screw (2), two flatwashers (3) and the self-locking nut (4).

(4) Connect electrical connector P22 (1).

4-7.3 ELECTRIC GOVERNOR MAGNETIC PICKUP.

a. Removal.

(1) Disconnect electrical connector P23 (1, figure 4-30.5).

(2) Loosen locknut (2) and unscrew the threaded magnetic pickup from the flywheel housing (3). Remove the magnetic pickup.

1. (P17)
2. Hex head screws (4)
3. Lockwasher (4)
4. Nuts (4)
5. Control unit

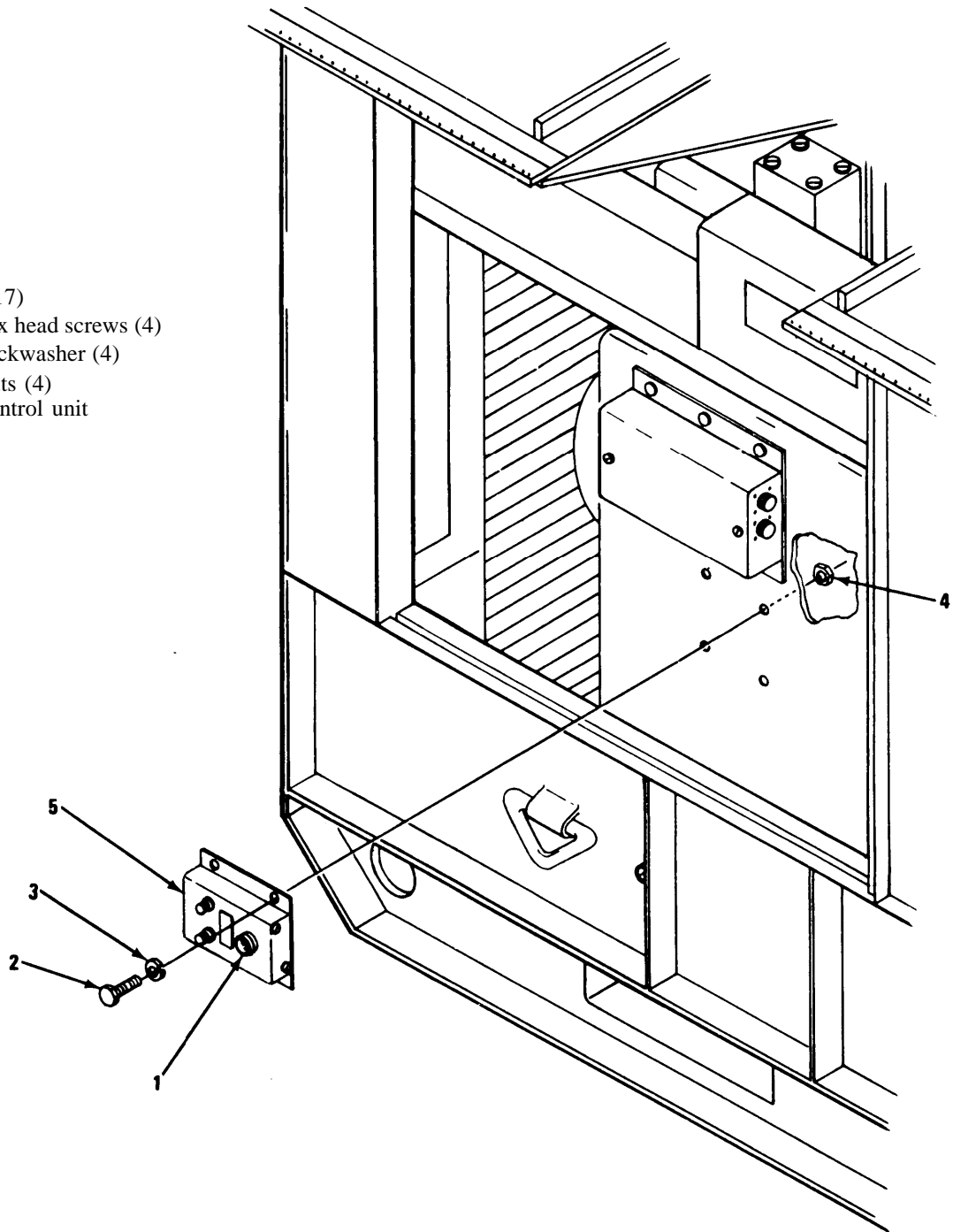

Figure 4-30.2. Governor Control Unit Removal and Installation

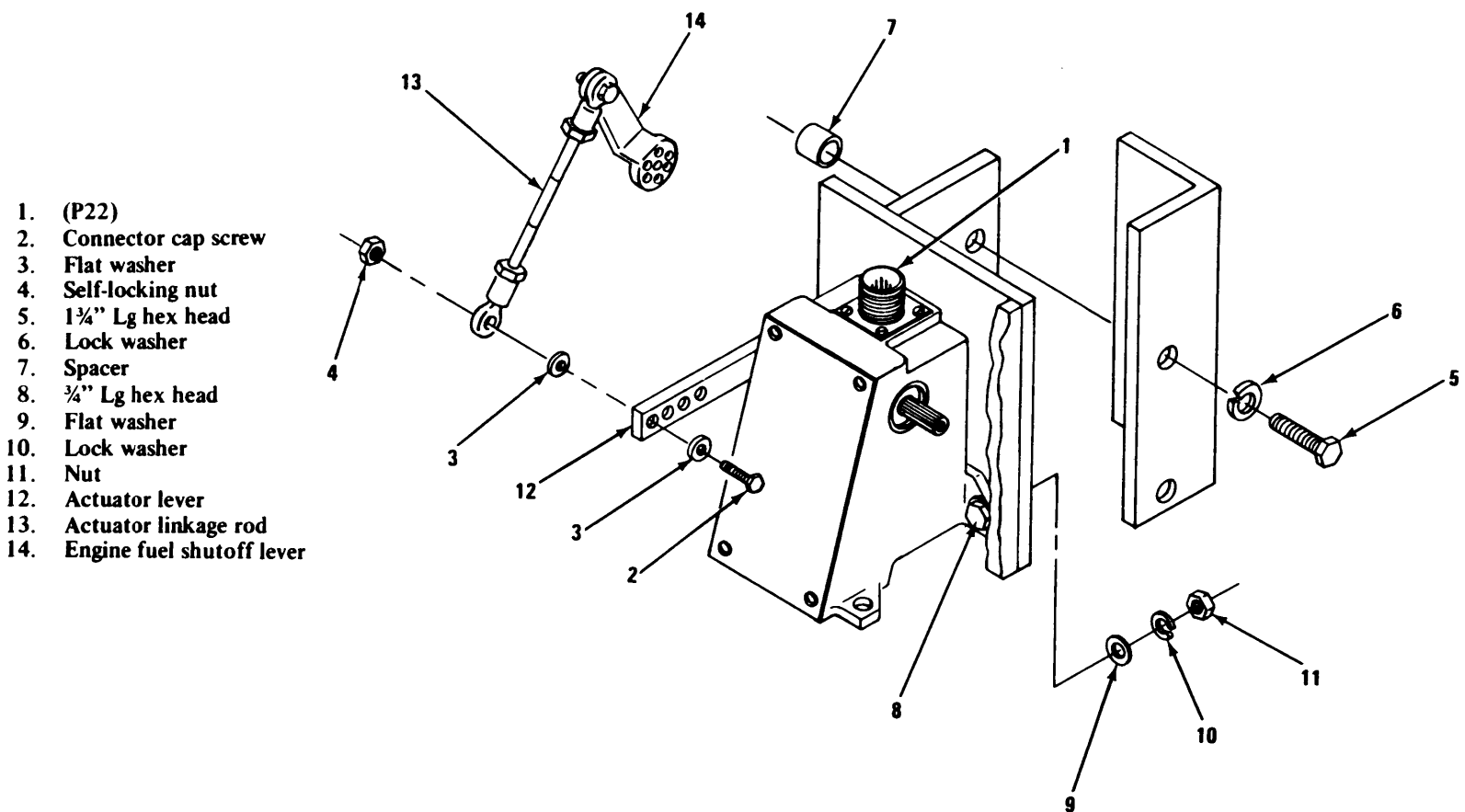
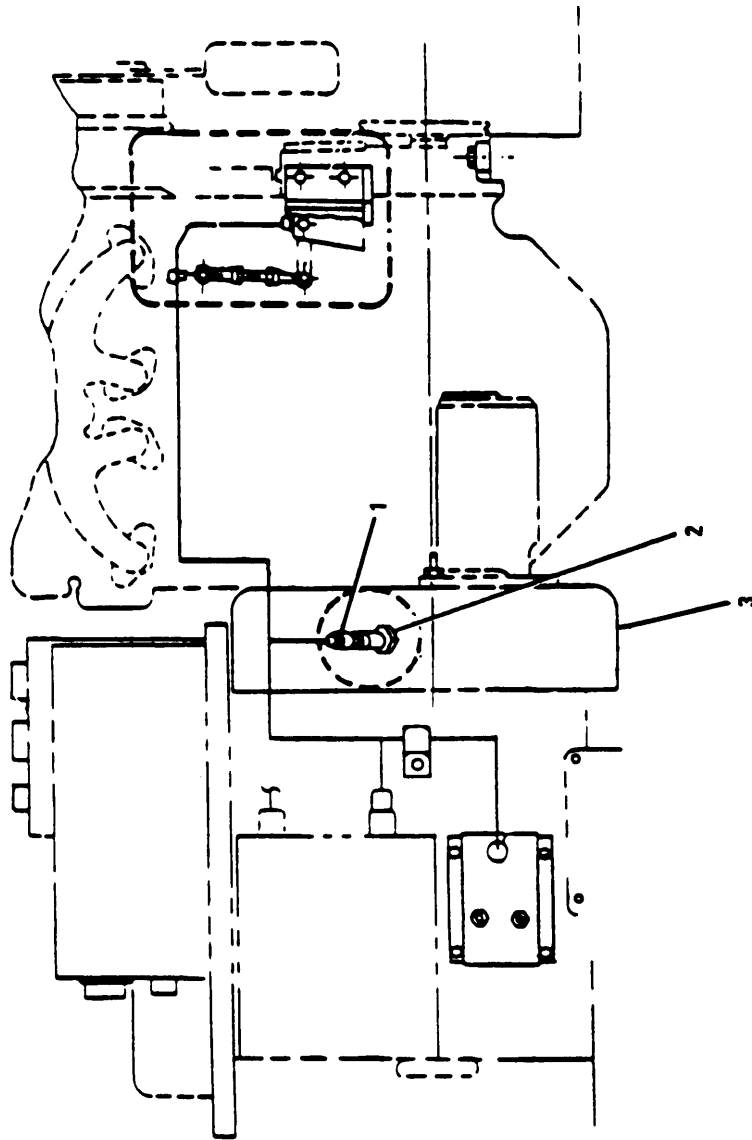

Figure 4-30.3. Actuator Removal And Installation





- 1. (P23)
- 2. Magnetic Pickup
- 3. Flywheel Housing

Figure 4-30.4. Magnetic Pickup Removal And Installation



## Section II. INTERCONNECTING WIRING HARNESES

### 4-8. GENERAL.

The interconnecting wiring harnesses provide electrical interconnection between generator set control devices and the control cubicle assembly. Each interconnecting wiring harness consists of connectors, terminals, and wires. The wires of each harness are strapped together to conserve space, prevent unnecessary movement, and provide ease of removal and installation. Wiring harnesses which are internal to an assembly are not covered in this section. Refer to the maintenance paragraph for the assembly for internal wiring harness repair procedures.

### 4-9. TACTICAL RELAY ASSEMBLY TO SPECIAL RELAY ASSEMBLY WIRING HARNESS.

a. Refer to the Operator and Organizational Maintenance Manual for removal, cleaning, inspection, and repair procedures of tactical relay assembly to special relay assembly wiring harness.

b. If the wiring harness has sustained damage and requires repair or rebuild, refer to figure 4-30 for layout, identification, and material requirements and Appendix A for detailed soldering and replacement procedures.

c. Refer to the Operator and Organizational Maintenance Manual for installation instructions.

### 4-10. SPECIAL RELAY ASSEMBLY TO STATIC EXCITER WIRING HARNESS.

a. Refer to the Operator and Organizational Maintenance Manual for special relay assembly to static exciter wiring harness removal, cleaning, inspection, and repair instructions.

b. If the wiring harness has sustained damage and requires repair or rebuild, refer to figure 4-31 for layout, identification, and material requirements and Appendix A for detailed soldering and replacement procedures.

c. Refer to the Operator and Organizational Maintenance Manual for wiring harness installation procedures.

### 4-11. LOAD MEASURING UNIT TO TACTICAL RELAY ASSEMBLY WIRING HARNESS.

a. Refer to the Operator and Organizational Maintenance Manual for load measuring unit to tactical relay assembly wiring harness removal, cleaning, inspection, and repair instructions.

b. If the wiring harness has sustained damage and requires repair or rebuild, refer to figure 4-32

for layout, identification, and material requirements and Appendix A for detailed soldering and replacement procedures.

c. Refer to the Operator and Organizational Maintenance Manual for wiring harness installation instructions.

### 4-12. GOVERNOR CONTROL UNIT TO HYDRAULIC ACTUATOR UNIT WIRING HARNESS.

a. Refer to the Operator and Organizational Maintenance Manual for governor control unit to hydraulic actuator unit wiring harness removal, cleaning, inspection, and repair instructions.

b. If the wiring harness has sustained damage and requires repair or rebuild, refer to figure 4-33 for layout, identification, and material requirements and Appendix A for detailed soldering and replacement procedures.

c. Refer to the Operator and Organizational Maintenance Manual for installation instructions.

### 4-13. AC POWER CONTROL WIRING HARNESS.

a. Refer to the Operator and Organizational Maintenance Manual for ac power control wiring harness removal, cleaning, inspection, and repair instructions.

b. If the wiring harness has sustained damage and requires repair or rebuild, refer to figure 4-34 for layout, identification, and material requirements and Appendix A for detailed soldering and replacement procedures.

c. Refer to the Operator and Organizational Maintenance Manual for wiring harness installation instructions.

### 4-14. EXCITER CONTROL WIRING HARNESS.

a. Refer to the Operator and Organizational Maintenance Manual for exciter control wiring harness removal, cleaning, inspection, and repair instruction.

b. If the wiring harness has sustained damage and requires repair or rebuild, refer to figure 4-35 for layout, identification, and material requirements and Appendix A for detailed soldering and replacement procedures.

c. Refer to the Operator and Organizational Maintenance Manual for wiring harness installation procedures.

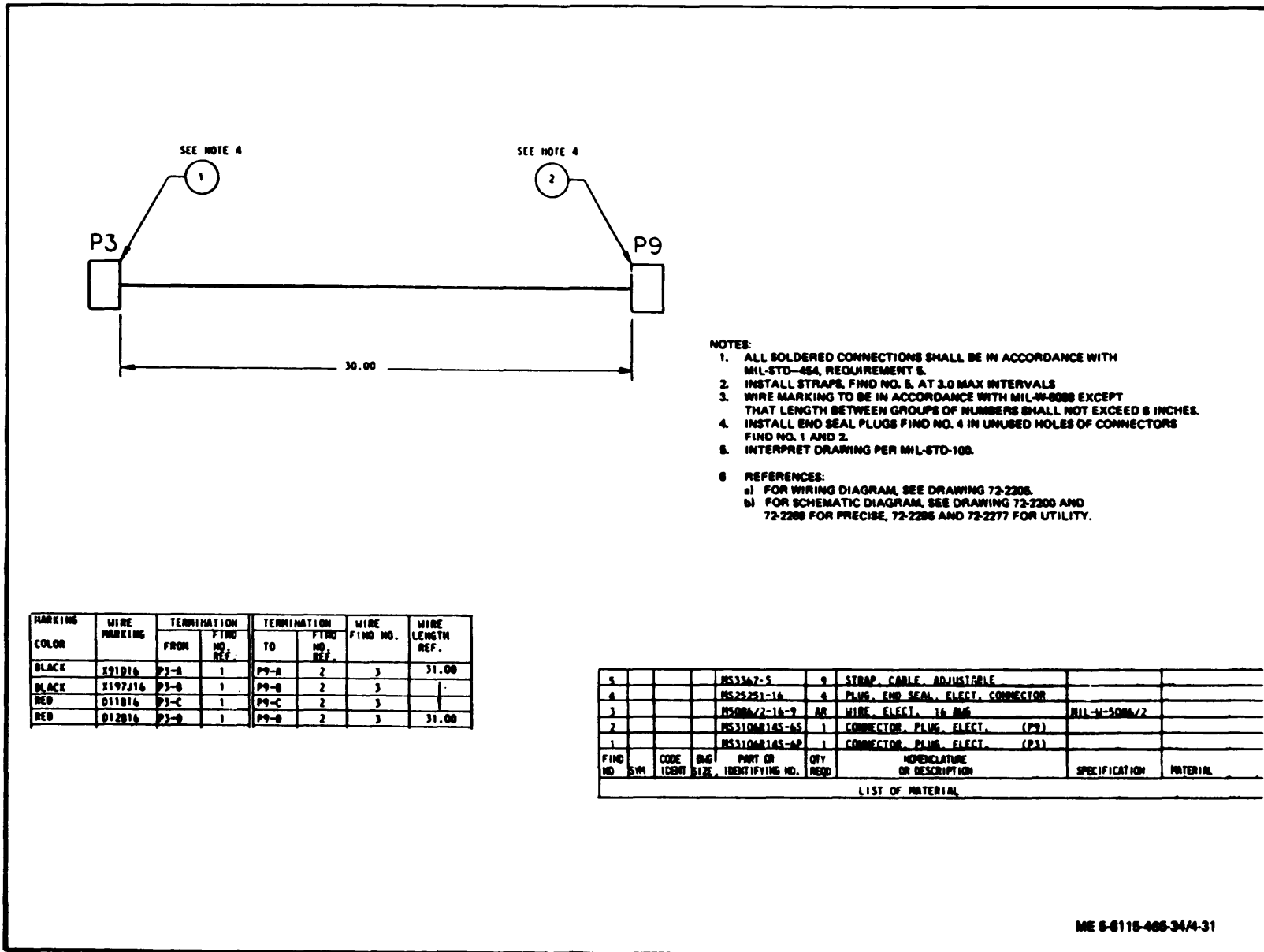

- NOTES:**
1. ALL SOLDERED CONNECTIONS SHALL BE IN ACCORDANCE WITH MIL-STD-454, REQUIREMENT 5.
  2. INSTALL STRAPS, FIND NO. 5, AT 3.0 MAX INTERVALS
  3. WIRE MARKING TO BE IN ACCORDANCE WITH MIL-W-8888 EXCEPT THAT LENGTH BETWEEN GROUPS OF NUMBERS SHALL NOT EXCEED 8 INCHES.
  4. INSTALL END SEAL PLUGS FIND NO. 4 IN UNUSED HOLES OF CONNECTORS FIND NO. 1 AND 2.
  5. INTERPRET DRAWING PER MIL-STD-100.
- REFERENCES:**
- a) FOR WIRING DIAGRAM, SEE DRAWING 72-2205.
  - b) FOR SCHEMATIC DIAGRAM, SEE DRAWING 72-2200 AND 72-2288 FOR PRECISE, 72-2286 AND 72-2277 FOR UTILITY.

MARKING	WIRE MARKING	TERMINATION		TERMINATION		WIRE FIND NO.	WIRE LENGTH REF.
		FROM	TO	FROM	TO		
BLACK	X19116	P3-A	1	P9-A	2	3	31.00
BLACK	X197116	P3-B	1	P9-B	2	3	
RED	D11816	P3-C	1	P9-C	2	3	
RED	D12816	P3-D	1	P9-D	2	3	31.00

FIND NO	SYN	CODE	QTY	PART OR IDENTIFYING NO.	QTY	Nomenclature or Description	SPECIFICATION	MATERIAL
5				MS3367-5	9	STRAP, CABLE, ADJUSTABLE		
4				MS25251-16	4	PLUG, END SEAL, ELECT, CONNECTOR		
3				MS5086/2-16-9	AR	WIRE, ELECT, 16 AWG		MIL-W-5086/2
2				MS3106/145-6S	1	CONNECTOR, PLUG, ELECT. (P9)		
1				MS3106/145-AP	1	CONNECTOR, PLUG, ELECT. (P3)		

LIST OF MATERIAL

ME 5-6115-465-34/4-31

Figure 4-31. Special Relay Assembly to Static Exciter Assembly Wiring Harness, Drawing No. 72-2220

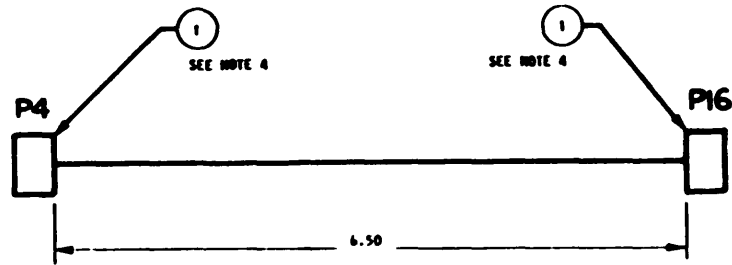

**NOTES:**

1. ALL SOLDERED CONNECTIONS SHALL BE IN ACCORDANCE WITH MIL-STD-884, REQUIREMENT 5.
2. INSTALL STRAPS, FWD NO. 3, AT 3.0 MAX INTERVALS.
3. WIRE MARKING TO BE IN ACCORDANCE WITH MIL-STD-883B EXCEPT THAT LENGTH BETWEEN GROUPS OF NUMBERS SHALL NOT EXCEED 6 INCHES.
4. INSTALL END SEAL PLUGS, FWD NO. 4 IN UNUSED HOLES OF CONNECTORS FWD NO. 1.
5. INTERPRET DRAWING PER MIL-STD-100.
6. REFERENCES
  - a) FOR WIRING DIAGRAM, SEE DRAWING 73-2205.
  - b) FOR SCHEMATIC DIAGRAM, SEE DRAWING 73-2200 AND 73-2208.

MARKING COLOR	WIRE MARKING	TERMINATION		TERMINATION		WIRE LENGTH REF.		
		FROM	FWD NO. REF.	TO	FWD NO. REF.			
BLACK	X7G16A	P4-A	1	P16-A	1	7.50		
	X8G16B	P4-B	1	P16-B	1			
	X9N16C	P4-C	1	P16-C	1			
	X11SD16	P4-D	1	P16-D	1			
	X116D16	P4-E	1	P16-E	1			
	X117D16	P4-F	1	P16-F	1			
	D26G16	P4-G	1	P16-G	1			
	X12Y16H	P4-K	1	P16-K	1			
	X12Z16H	P4-L	1	P16-L	1			
	X12AA16H	P4-M	1	P16-M	1			
	K101A16	P4-N	1	P16-N	1			
	K102A16	P4-S	1	P16-S	1			
	BLACK							7.50

**BWD**

FWD NO.	SYM.	CODE IDENT	DRG SIZE	PART NO. IDENTIFYING NO.	QTY REQD	NOMENCLATURE OR DESCRIPTION	SPECIFICATION	MATERIAL
1				MS3108R20-29S	2	CONNECTOR, PLUG ELECT. P4, P16		
2				MS088/2-16-9	AR	WIRE, ELECT., 16 AWG	MIL-W-8088/2	
3				MS3367-5	2	STRAP, CABLE, ADJUSTABLE		
4				MS25251-16	10	PLUG, FWD SEAL, ELECT. CONNECTOR		

ME 5-6115-465-34/4-32

Figure 4-32. Load Measuring Unit to Tactical Relay Assembly Wiring Harness, Drawing No. 72-2234

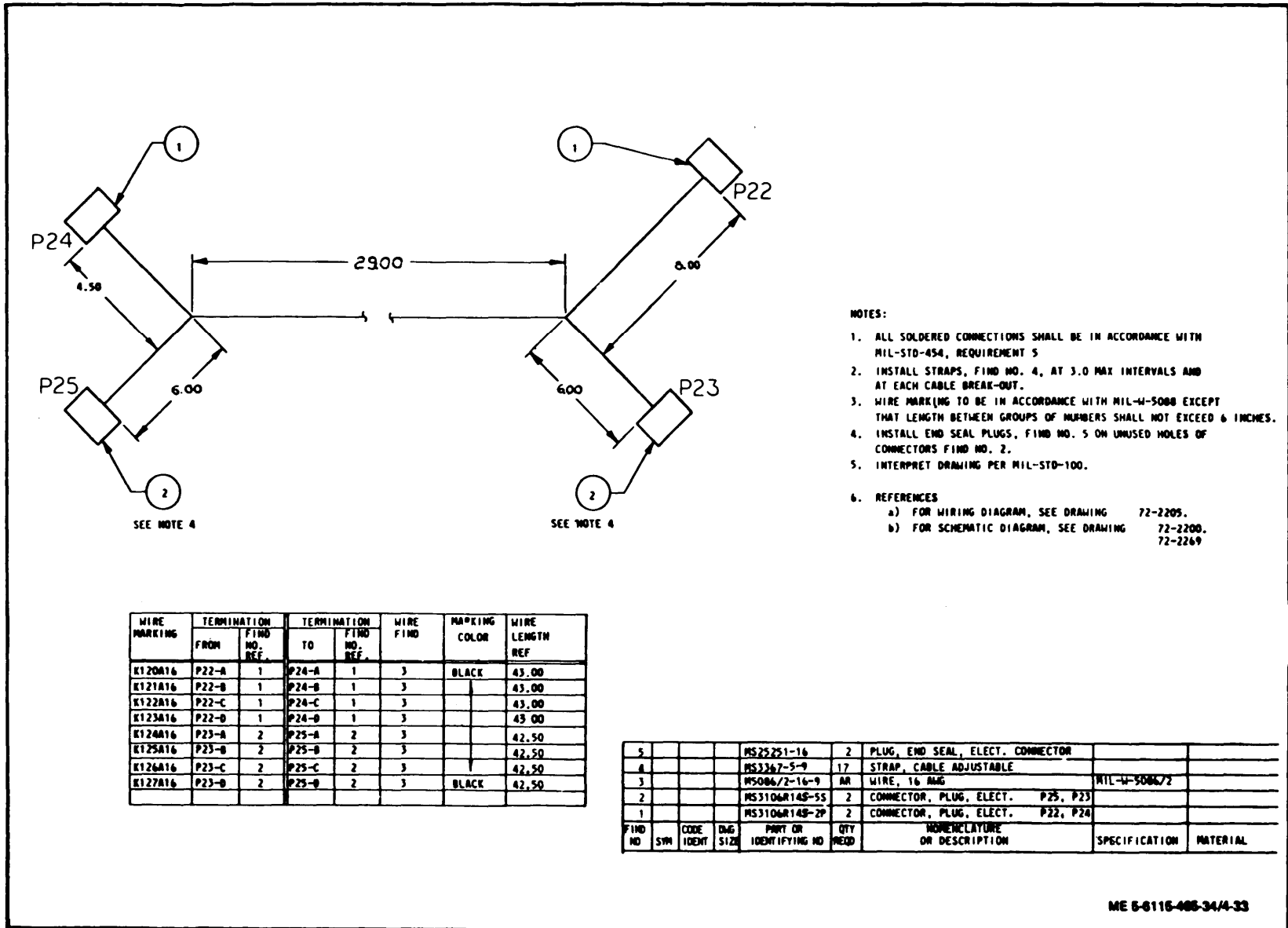

Figure 4-33. Governor Control Unit to Hydraulic Actuator Unit Wiring Harness, Drawing No. 72-2282

ME 5-6115-465-34/4-33

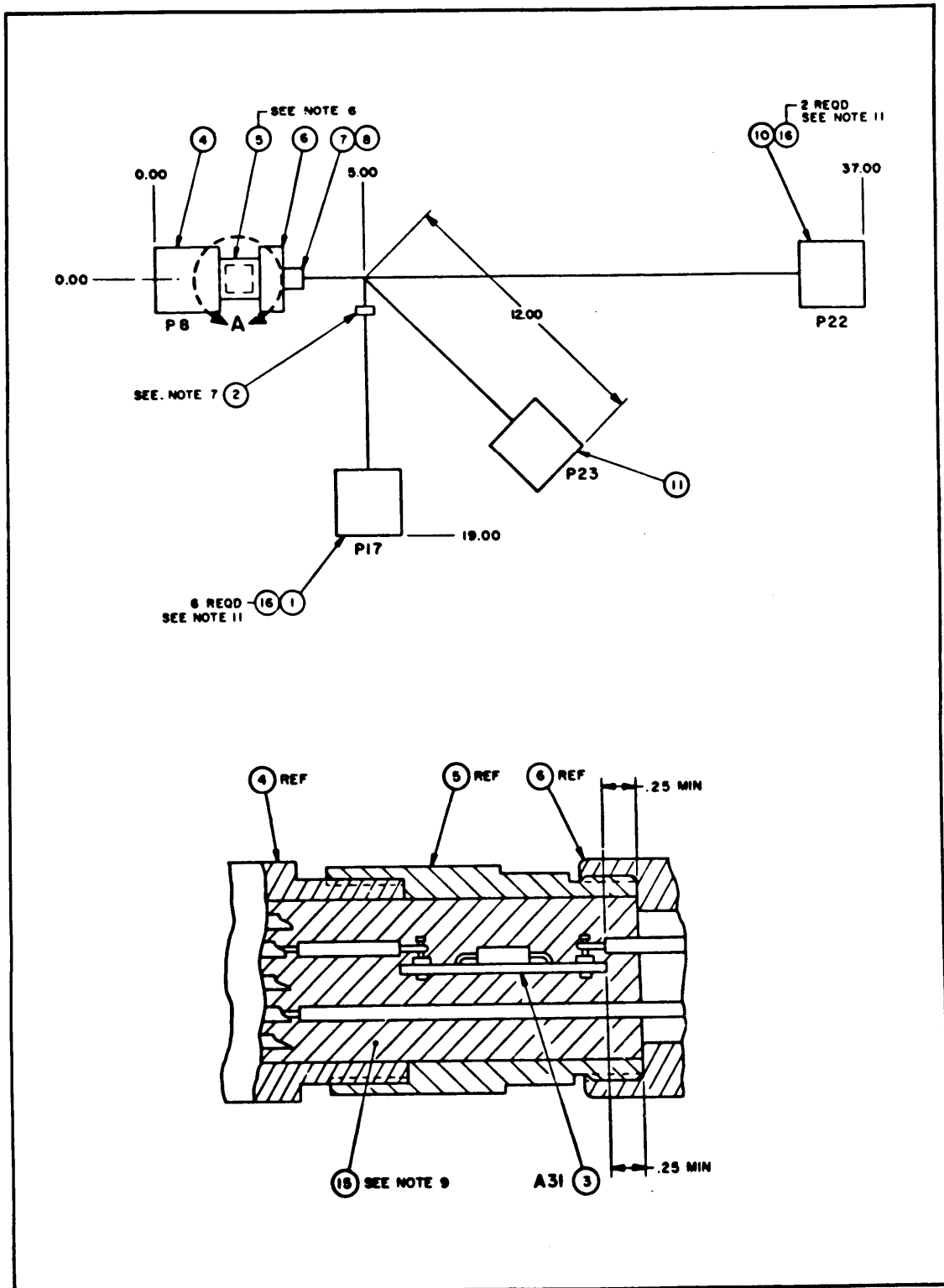

Figure 4-33.1. 400 Hz Electric Governor System Wiring  
 Harness Assembly Drawing No. 84-704  
 (Sheet 1 of 2)

NOTES:

1. ALL CONDUCTOR ENDS SHALL BE STRIPPED 50 ± 12 AND TINNED BEFORE ASSEMBLY USING SOLDER, FIND NO. 12.
2. ELECTRICAL CONNECTIONS SHALL BE SOLDERED IN ACCORDANCE WITH MIL-STD-883C, REQUIREMENT 5, USING SOLDER, FIND NO. 12.
3. WIRE MARKING SHALL BE IN ACCORDANCE WITH MIL-W-5088 EXCEPT THAT INTERVALS SHALL NOT EXCEED 6.00
4. TIEDOWN STRAPS, FIND NO. 13, SHALL BE LOCATED APPROXIMATELY 3.00 APART AND AT ALL BREAKOUTS.
5. CONNECTORS, FIND NO. 1, 4, 10, 11, SHALL BE MARKED WITH REFERENCE DESIGNATIONS SHOWN IN ACCORDANCE WITH MIL-STD-130, USING .25 HIGH CHARACTERS.
6. EXTENSION, FIND NO. 5, SHALL BE MARKED "A31" IN ACCORDANCE WITH MIL-STD-130, USING .25 HIGH CHARACTERS.
7. BAND MARKER, FIND NO. 2, SHALL BE MARKED WITH PART NO. "30684/P3-2005" IN ACCORDANCE WITH MIL-STD-130.
8. FOR INTERPRETATION OF: DRAWING, SEE DOD-STD-100.
9. FILL COMPLETE INSIDE AREA OF CONNECTOR EXTENSION, FIND NO. 5 WITH POTTING COMPOUND, FIND NO. 15.
10. CONNECTOR, FIND NO. 11, SHALL BE IN ACCORDANCE WITH MS3106R, INSERT ARRANGEMENT 10SL-4S.
11. SEAL UNUSED HOLES IN GROMMETS OF CONNECTORS, FIND NO. 1 AND 10, WITH PLUGS, FIND NO. 16.
12. THE CONDUCTORS OF WIRE NUMBERS 13, 14, 15 AND 21 SHALL BE TWISTED TOGETHER AND SOLDERED. THE CONNECTION SHALL BE COVERED WITH HEAT SHRINK INSULATION SLEEVING, FIND NO. 17. THIS CONNECTION SHALL BE POSITIONED TO CLEAR THE PRINTED WIRING BOARD ASSEMBLY, FIND NO. 3, PRIOR TO POTTING IN ACCORDANCE WITH NOTE 9.

WIRE RUNNING LIST

WIRE NO.	WIRE MARKING (SEE NOTE 3)	TERMINATION		TERMINATION		WIRE LENGTH	WIRE FIND NO.
		FROM	FIND NO.	TO	FIND NO.		
1	(JUMPER)	PB-J		A31-1		1.50	9
2	(JUMPER)	PB-H		A31-2		1.50	9
3	(JUMPER)	PB-P		A31-3		1.50	9
4	(JUMPER)	PB-T		A31-4		1.50	9
5	K111A16	A31-5		P17-H		22.00	14
6	K10B316	A31-6		P17-J		22.00	14
7	K10H316	A31-7		P17-K		22.00	14
8	K32F16	PB-M		P17-R		24.00	14
9	K10J316	PB-N		P17-F		24.00	14
10	PB1A16	PB-C		P17-C		24.00	14
11	P55G316	PB-D		P17-G		24.00	14
12	(JUMPER)	PB-U		PB-F		2.00	9
13	(JUMPER)	PB-G		---		1.50	9
14	(JUMPER)	PB-R		---		1.50	9
15	(JUMPER)	PB-E		---		1.50	9
16	K122A16	P17-T		P23-A		31.00	14
17	K122A16	P17-S		P23-B		31.00	14
18	(JUMPER)	P22-B		P22-C		3.00	14
19	K126A16	P17-B		P22-A		51.00	14
20	K127A16	P17-D		P22-O		51.00	14
21	(JUMPER)	PB-S		---		1.50	9

SEE NOTE 1  
 TWISTED PAIR  
 SEE NOTE 12

17		M23053/7-104-C	AR	INSULATION SLEEVING 187 10 AS SUPPLIED		MIL-I-23053/7	
16		M525251-16	B	PLUG END SEAL (22-16 WIRE SIZE)			
15		TYPE LCL 1 GR B1	AR	SEALING COMPOUND		MIL-S-22586	
14		M5086/2 16-9	AR	WIRE ELECTRICAL 16 AWG WHT		MIL-W-5086/2	
13		M53367 7-9	AR	STRAP TIEDOWN			
12		SN604RP2	AR	SOLDER		QQ-S-571	
11		SEE NOTE 10	I	CONNECTOR PLUG	P23	MIL-C-5015	
10		MS3106R14S 6S	I	CONNECTOR PLUG	P22		
9		M53367 7-9	AR	WIRE ELECTRICAL 16 AWG WHT		MIL-W-5086/2	
8		M53367 7-9	I	ADAPTER			
7		M53420-12	I	ADAPTER			
6		M53057 16A	I	CLAMP CABLE			
5	C	B1-4917	I	EXTENSION CONNECTOR			
4		M53106A24-20P	I	CONNECTOR PLUG	PB		
3	C	B3 2012	I	PRINTED WIRING BOARD ASSY. LOAD SHARING A31			
2		M43436/1 3	I	BAND MARKER BLANK		MIL-B-43436/1	
1		M53106P20 20S	I	CONNECTOR PLUG	P17		
FIG NO	FIG	DWG SIZE	PART OR IDENTIFYING NO	QUANTITY	NOMENCLATURE OR DESCRIPTION	SPECIFICATION	MATERIAL

Figure 4-33.1. 400 Hz Electric Governor System Wiring  
 Harness Assembly Drawing No. 84-704  
 (Sheet 2 of 2)



WIRE MARKING	TERMINATION				WIRE LENGTH REF	WIRE MARKING COLOR
	FROM	FIND NO REF	TO	FIND NO REF		
B20E16	P10-A	1	CT1-B2	5	16.75	BLACK
B21E16	P10-B	A	CT2-B2	A	21.50	
B22E16	P10-C		CT2-C2		22.00	
X17E16	P10-D		CT1-B1		19.00	
X18E16	P10-J		CT2-B1		22.00	
X19E16	P10-L		CT2-C1	5	25.50	
X195M16	P10-V		CT7-B2	10	26.25	
X194F16	P10-W		CT7-B1	10	25.50	
X14M16	P10-G		TD6-1	7	35.50	
X7E16	P10-E		TD6-7	7	34.75	
X15F16	P10-H		TD6-2	7	35.50	
X8A16	P10-F		TD6-8	7	34.75	
Z14M16	P10-L		TD6-3	7	39.25	
X9X16	P10-X		TD6-9	7	38.50	
X12E16	P10-I		TD6-12	7	35.75	
X6A16	P10-S		TD6-6	7	37.50	BLACK
P55W12	P10-D		ES-IND 0	1	60.00	RED
X21S16	P10-I		EB2-B	7	38.00	BLACK
X22S16	P10-Y		EB2-B2	7	38.00	BLACK
P63F16	P10-U		P41-A	3	31.50	RED
P55DY16	P10-Z		P41-B	A	31.50	RED
P56L16	P10-d		P41-C		31.50	RED
P50Z16	P10-c		P41-D		31.50	RED
X97B16	P10-N		P41-E		31.50	BLACK
X96G16	P10-M		P41-F		31.50	
F112M16	P10-j		P41-G		31.50	
X110E16	P10-b		P41-H		31.50	BLACK
P50X16	P10-A	1	P41-J		31.50	RED
P190R16	P10-h	1	P41-K	3	31.50	RED

NOTES:

- ALL SOLDERED CONNECTIONS SHALL BE IN ACCORDANCE WITH MIL-STD-884, REQUIREMENT 5.
- INSTALL STRAPS, FIND NO. 9, AT 3.0 MAXIMUM INTERVALS AND AT EACH CABLE BREAK-OUT.
- WIRE MARKING TO BE IN ACCORDANCE WITH MIL-W-5008 EXCEPT THAT LENGTH BETWEEN GROUPS OF NUMBERS SHALL NOT EXCEED 6 INCHES.
- CRIMPED TERMINALS SHALL MEET THE PERFORMANCE REQUIREMENTS OF MIL-T-7928.
- INSTALL END SEAL PLUGS, FIND NO 2 IN UNUSED HOLES OF CONNECTOR, FIND NOS 1 AND 3.
- INTERPRET DRAWING PER MIL-STD-100.
  - FOR WIRING DIAGRAM, SEE DRAWING 72-2205.
  - FOR SCHEMATIC DIAGRAM, SEE DRAWING 72-2.00 AND 72-2269.

11				MS006/2-12-9	AR	WIRE, ELECTRICAL, 12 AWG	MIL-W-5006/2	
10				MS25036-100	2	TERMINAL LUG, NO. 10, 16 AWG		
9				MS2367-4-9	AR	STRAP, CABLE, ADJUSTABLE		
8				MS25036-113	1	TERMINAL LUG, 5/16 STUD, 12 AWG		
7				MS25036-110	10	TERMINAL LUG, 3/8 STUD, 16 AWG		
6				MS006/2-16-9	AR	WIRE, ELECTRICAL, 16 AWG	MIL-W-5006/2	
5				MS25036-153	6	TERMINAL LUG, NO. 8 STUD, 16 AWG		
4						(M: USED)		
3				MS3106R20-295	1	CONNECTOR, PLUG, ELECTRICAL, P41		
2				MS25251-16	13	PLUG, END SEAL, ELEC. CONN.		
1				MS3106R32-75	1	CONNECTOR, PLUG, ELECTRICAL, P10		
FIND NO	SYM	CODE IDENT	DWG SIZE	PART OR IDENTIFYING NO	QTY REQD	NOMENCLATURE OR DESCRIPTION	SPECIFICATION	MATERIAL

LIST OF MATERIAL

Figure 4-34. AC Power Control Wiring Harness, Drawing No. 72-2259 (Sheet 1 of 2)



Figure 4-35. Exciter Control Wiring Harness, Drawing No. 73-2288

NOTES:

1. SOLDERING SHALL BE IN ACCORDANCE WITH MIL-STD-454, REQUIREMENT 5.
2. INSTALL STRAP, FIND NO. 8, AT 3.00 MAXIMUM INTERVALS AND AT EACH CABLE BREAK-OUT.
3. WIRE MARKING TO BE IN ACCORDANCE WITH MIL-W-5088 EXCEPT THAT LENGTH BETWEEN GROUPS OF NUMBERS SHALL NOT EXCEED 6.00 INCHES.
4. CRIMPED TERMINAL SHALL MEET THE PERFORMANCE REQUIREMENTS OF MIL-T-7920.
5. INSTALL END SEAL PLUGS, FIND NO. 2, IN UNUSED HOLES OF CONNECTOR, FIND NO. 1.
6. FOR INTERPRETATION OF REFERENCE DESIGNATIONS FOR ELECTRICAL AND ELECTRONIC PARTS AND EQUIPMENT, SEE AMSY 32.16.
7. REFERENCES:
  - a. FOR WIRING DIAGRAM SEE DRAWING 72-2205.
  - b. FOR SCHEMATIC DIAGRAM SEE DRAWINGS: 72-2200 AND 72-2269 FOR PRECISE. 72-2277 AND 72-2295 FOR UTILITY.
8. INTERPRET DRAWING PER MIL-STD-100.

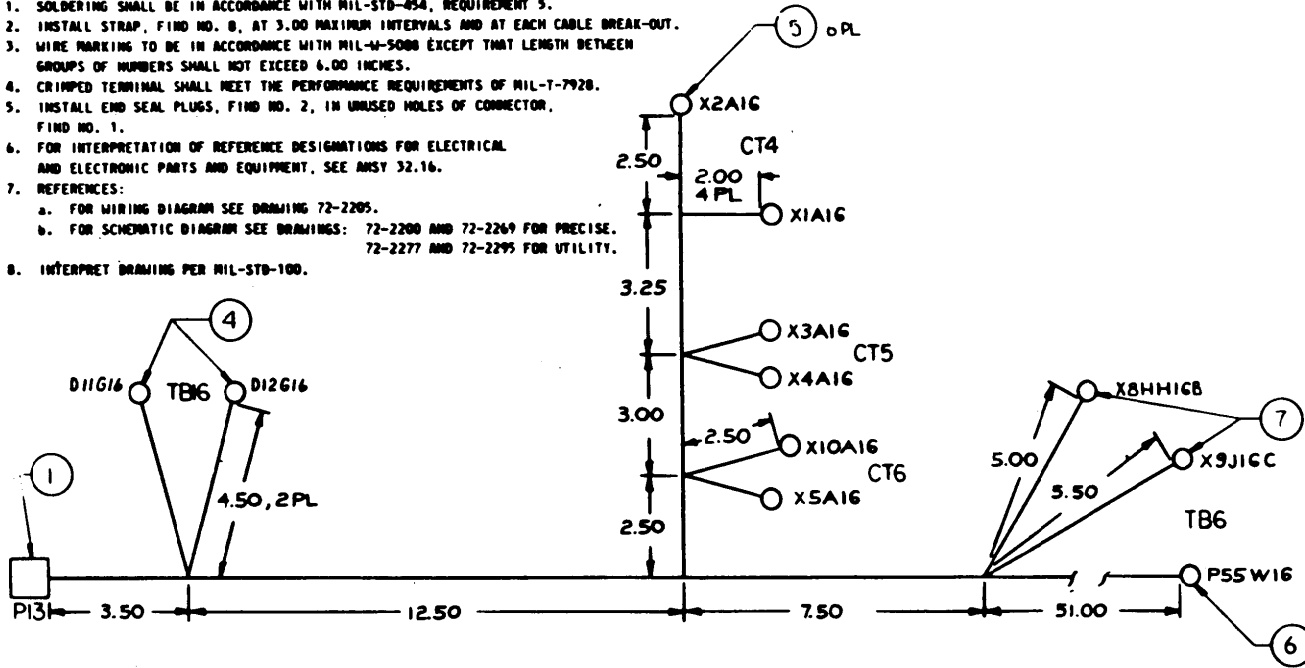

WIRE MARKING	TERMINATIONS				WIRE FIND NO	WIRE CUT LENGTH	WIRE MARKING COLOR
	FROM	FIND NO. REF.	TO	FIND NO. REF.			
X1A16	P12-B	1	CT4-A1	5	3	28.50	BLACK
X2A16	P12-B	1	CT4-A2	5	3	28.50	BLACK
X3A16	P12-E	1	CT5-B1	5	3	24.75	BLACK
X4A16	P12-F	1	CT5-B2	5	3	24.75	BLACK
X5A16	P12-J	1	CT6-C1	5	3	21.75	BLACK
X10A16	P12-K	1	CT6-C2	5	3	22.25	BLACK
X8HH16	P12-L	1	TR6-9	7	3	30.25	BLACK
X9J16C	P12-M	1	TR6-8	7	3	29.75	BLACK
D12G16	P12-R	1	TR16-2	4	3	9.25	RED
D11G16	P12-S	1	TR16-1	4	3	9.25	RED
P55W16	P12-T	1	E5	6	3	75.75	RED

FIND NO.	CODE	ENG.	PART OR IDENTIFYING NO.	QTY	NOMENCLATURE OR DESCRIPTION	SPECIFICATION	MATERIAL
8			MS3367-8-9	AR	STRAP, CABLE ADJUSTABLE		
7			MS25036-110	2	TERMINAL LUG, 3/8 STD, 16 AWG		
6			MS25036-154	1	TERMINAL LUG, 1/4 STD, 16 AWG		
5			MS25036-108	6	TERMINAL LUG, NO. 10 STD, 16 AWG		
4			MS25036-153	2	TERMINAL LUG, NO. 8 STD, 16 AWG		
3			MS08672-16-9	AR	WIRE, ELECT, 16 AWG	MIL-W-5086/2	
2			MS25251-16	8	PLUG, END SEAL, ELECT, CONN.		
1			MS3106R22-14S	1	CONNECTOR, PLUG, ELECT.	P13	

LIST OF MATERIAL

ME 5-6115-465-34/4-35

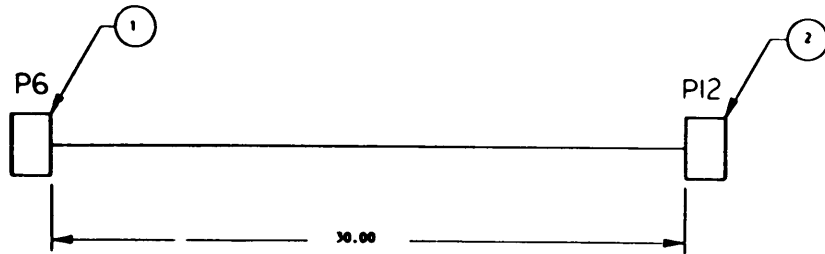

- NOTES:**
1. ALL SOLDERED CONNECTIONS SHALL BE IN ACCORDANCE WITH MIL-STD-464, REQUIREMENT 5.
  2. INSTALL STRAPS, FIND NO. 4, AT 3.0 MAX. INTERVALS.
  3. WIRE MARKING TO BE IN ACCORDANCE WITH MIL-W-5086 EXCEPT THAT LENGTH BETWEEN GROUPS OF NUMBERS SHALL NOT EXCEED 8 INCHES
  4. INSTALL END SEAL PLUGS, FIND NO. 5 IN UNUSED HOLES OF CONNECTOR FIND NO. 1 AND 2.
  5. INTERPRET DRAWING PER MIL-STD-100.
  6. REFERENCES
    - a) FOR WIRING DIAGRAM, SEE DRAWING 72-2205
    - b) FOR SCHEMATIC DIAGRAM, SEE DRAWINGS 72-2200 FOR PRECISE UNITS, 72-2200 NAD 72-2280 FOR UTILITY UNITS, 72-2286 AND 72-2277

MARKING	WIRE COLOR	WIRE MARKING	TERMINATION		WIRE FIND NO.	WIRE LENGTH REF.
			FROM	TO		
	RED	P45K16	P6-A	P12-A	2	31.00
		P6B16	P6-B	P12-B	2	3
		P200A16	P6-C	P12-C	2	3
		P201A16	P6-D	P12-D	2	3
		P202A16	P6-E	P12-E	2	3
		P203A16	P6-F	P12-F	2	3
		P204A16	P6-G	P12-G	2	3
		P205A16	P6-H	P12-H	2	3
		P206A16	P6-I	P12-I	2	3
		P207A16	P6-K	P12-K	2	3
		P208A16	P6-L	P12-L	2	3
		P209A16	P6-M	P12-M	2	3
	RED	P210A16	P6-N	P12-N	2	3

FIND NO	SYM	CODE IDENT	DWG SIZE	PART OR IDENTIFYING NO	QTY REQD	NOMENCLATURE OR DESCRIPTION	SPECIFICATION	MATERIAL
5				MS2251-16	2	PLUG, END SEAL, ELECT. CONNECTOR		
4				MS3367-5-9	9	STRAP, CABLE ADJUSTABLE		
3				MS08672-16-9	AR	WIRE, ELECT. 16 AWG	MIL-W-5086/2	
2				MS3106R20-27S	1	CONNECTOR, PLUG, ELECT. P12		
1				MS3106R20-27P	1	CONNECTOR, PLUG, ELECT. P6		

LIST OF MATERIAL

Figure 4-36. Special Relay Assembly to Fault Locating Indicator Wiring Harness, Drawing No. 76-2247

4-15. SPECIAL RELAY ASSEMBLY TO FAULT  
LOCATING INDICATOR WIRING HARNESS.

a. Refer to the Operator and Organizational Maintenance Manual for special relay assembly to fault locating indicator wiring harness removal, cleaning, inspection, and repair procedures.

b. If the wiring harness has sustained damage and requires repair or rebuilding, refer to figure 4-36 for layout, identification, and material requirements and Appendix A for detailed soldering and replacement procedures.

c. Refer to the Operator and Organizational Maintenance Manual for wiring harness installation instructions.

4-16. SPECIAL RELAY ASSEMBLY TO CONTROL  
CUBICLE ASSEMBLY WIRING HARNESS.

a. Refer to the Operator and Organizational Maintenance Manual for special relay assembly to control cubicle assembly wiring harness removal, cleaning, inspection, and repair procedures.

b. If the Wiring harness has sustained damage and requires repair or rebuild, refer to figure 4-37 for layout, identification, and material requirements and Appendix A for detailed soldering and replacement procedures.

c. Refer to the Operator and Organizational Maintenance Manual for wiring harness installation instructions.

4-17. PRECISE RELAY ASSEMBLY TO GOVERNOR  
CONTROL UNIT WIRING HARNESS.

a. Refer to the Operator and Organizational Maintenance Manual for precise relay assembly to governor control unit wiring harness removal, cleaning, inspection, and repair instructions.

b. If the wiring harness has sustained damage and requires repair or rebuild, refer to figure 4-38 for layout, identification, and material requirements and Appendix A for detailed soldering and replacement procedures.

c. Refer to the Operator and Organizational Maintenance Manual for wiring harness installation instructions.

4-18. SPECIAL RELAY ASSEMBLY TO PRECISE  
RELAY ASSEMBLY WIRING HARNESS.

a. Refer to the Operator and Organizational Maintenance Manual for special relay assembly to precise relay assembly wiring harness removal, cleaning, inspection, and repair instructions.

b. If the wiring harness has sustained damage, and requires repair or rebuild, refer to figure 4-39 for layout, identification, and material requirements and Appendix A for detailed soldering and replacement procedures.

c. Refer to the Operator and Organizational Maintenance Manual for wiring harness installation instructions.

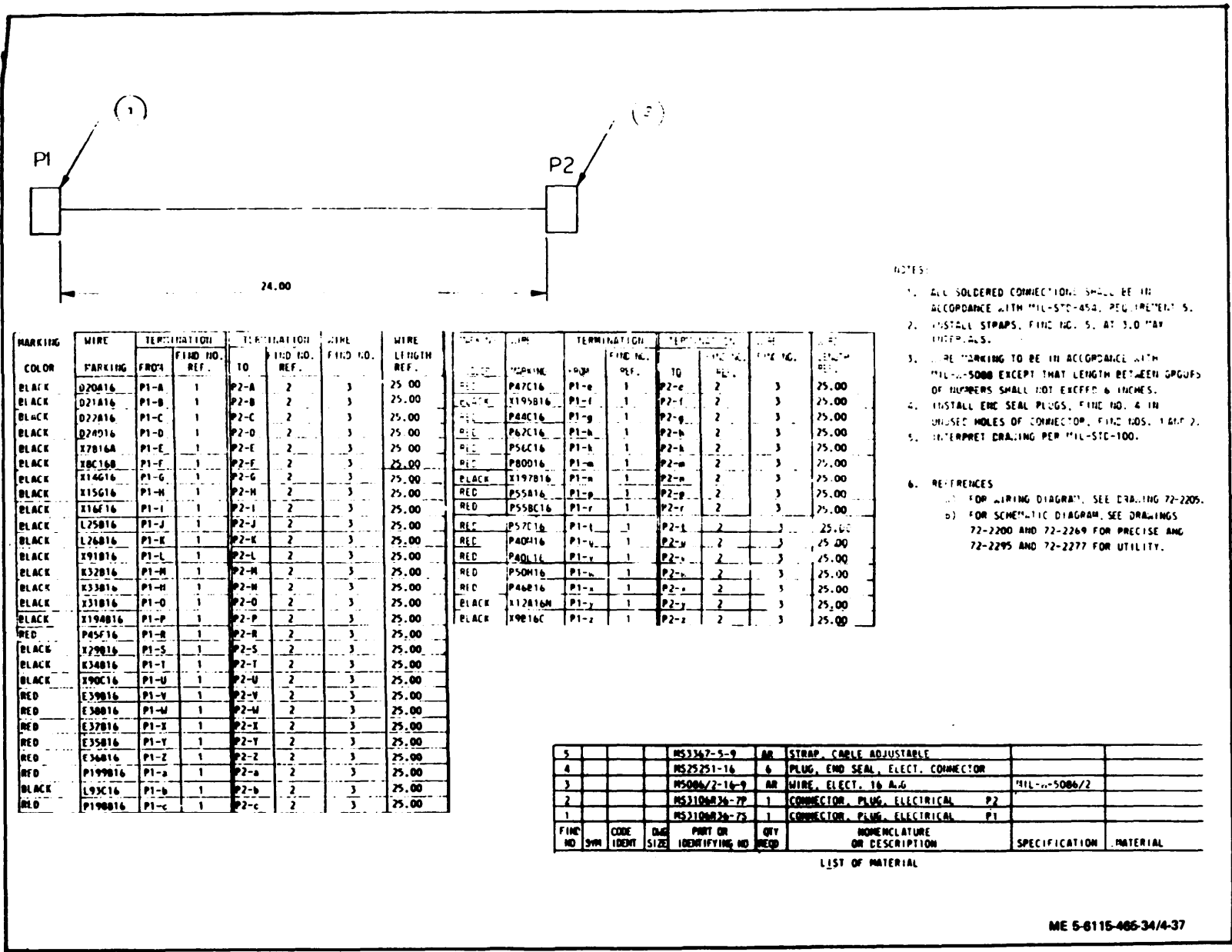
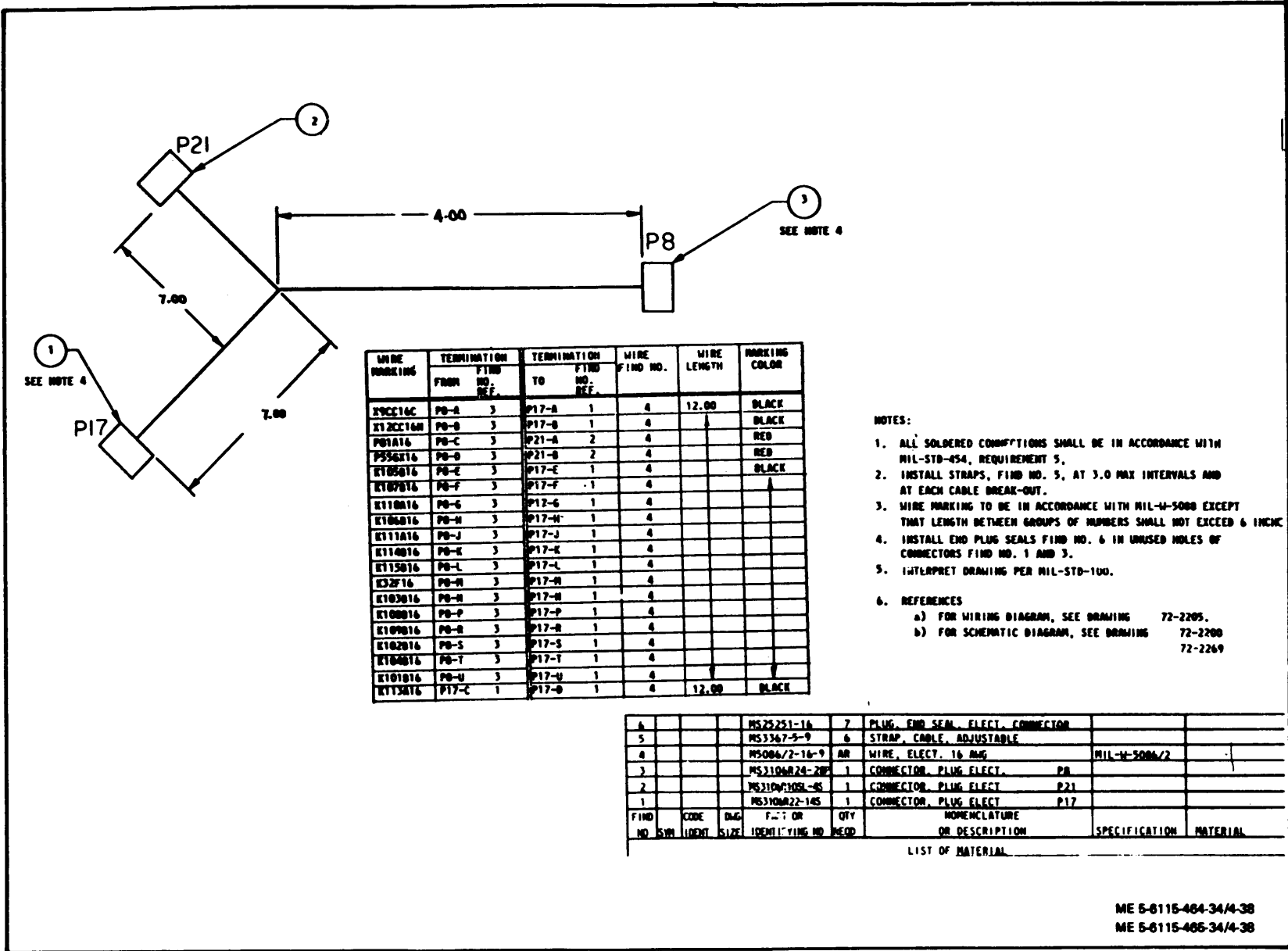
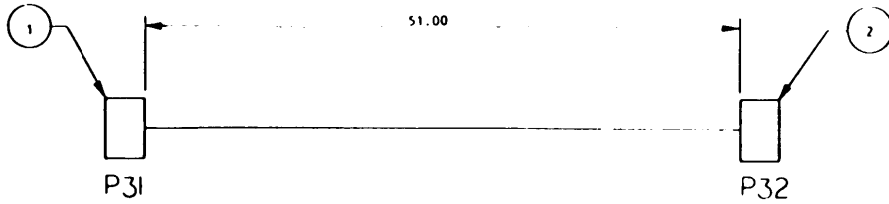

Figure 4-37. Special Relay Assembly to Control Cubicle Wiring Harness, Drawing No. 72-2248

Figure 4-38. Precise Relay Assembly to Governor Control Unit Wiring Harness, Drawing No. 72-2245



TM 5-6115-485-34  
TO 35C2-3-446-2  
NAVFAC P-8-625-34  
TM 068558B/068599D-34



NOTES:

1. ALL SOLDERED CONNECTIONS SHALL BE IN ACCORDANCE WITH MIL-STD 454, REQUIREMENT 5.
2. INSTALL STRAPS, FIND NO. 4, AT 3.0 MAX INTERVALS.
3. WIRE MARKING TO BE IN ACCORDANCE WITH MIL-W-5088 EXCEPT THAT LENGTH BETWEEN GROUPS OF NUMBERS SHALL NOT EXCEED 6 INCHES.
4. INSTALL END SEAL PLUGS, FIND NO. 5 IN UNUSED HOLES OF CONNECTORS FIND NO. 1 AND 2.
5. INTERPRET CRAMING PER MIL-STD-103.
6. REFERENCES
  - a) FOR WIRING DIAGRAM, SEE DRAWING 72-2205.
  - b) FOR SCHEMATIC DIAGRAM, SEE DRAWING 72-2200 AND 72-2269.

MARKING	WIRE MARKING	TERMINATION		TERMINATION		WIRE FIND NO.	WIRE LENGTH REF.
		FROM	REF.	TO	REF.		
BLACK	X9R16C	P31-A	1	P32-A	2	3	52.00
BLACK	X12S16H	P31-B	1	P32-B	2	3	
RED	P81C16	P31-C	1	P32-C	2	3	
	P55HM16	P31-D	1	P32-D	2	3	
	P50U16	P31-E	1	P32-E	2	3	
	P20AC16	P31-F	1	P32-F	2	3	
BLACK	K110C16	P31-G	1	P32-G	2	3	
RED	P60016	P31-H	1	P32-H	2	3	
BLACK	K111C16	P31-J	1	P32-J	2	3	
RED	P200F16	P31-K	1	P32-K	2	3	
RED	P57K16	P31-L	1	P32-L	2	3	
BLACK	K32D16	P31-M	1	P32-M	2	3	
	K33D16	P31-N	1	P32-N	2	3	
	L93E16	P31-P	1	P32-P	2	3	
	X15K16	P31-R	1	P32-R	2	3	
	X102C16	P31-S	1	P32-S	2	3	
	K34D16	P31-T	1	P32-T	2	3	
	K101C16	P31-U	1	P32-U	2	3	
RED	P210C16	P31-V	1	P32-V	2	3	
RED	P55R16	P31-Z	1	P32-Z	2	3	52.00

FIND NO.	CODE	QTY	PART OR IDENTIFYING NO.	QTY	NOMENCLATURE OR DESCRIPTION	SPECIFICATION	MATERIAL
5			MS25251-16	8	PLUG, END SEAL, ELECT. CONNECTOR		
4			MS3367-5-9	16	STRAP, CABLE, ADJUSTABLE		
3			MS086/2-16-9	AR	WIRE, ELECT. 16 AWG	MIL-W-5086/2	
2			MS3106R24-28S	1	CONNECTOR, PLUG, ELECT	P32	
1			MS3106R24-28P	1	CONNECTOR, PLUG, ELECT.	P31	

LIST OF MATERIAL

4-52  
 Figure 4-39. Special Relay Assembly to Precise Relay Assembly, Drawing No. 72-2238



## CHAPTER 5

### GENERATOR REPAIR INSTRUCTIONS

#### Section I. CONVENIENCE AND PARALLELING RECEPTACLES AND WIRING HARNESS

##### 5-1. GENERAL.

a. All models of the generator set are equipped with a 125 volt, 15 amp convenience receptacle. The receptacles equipped with a spring loaded weather cover and protected by a 15 amp circuit breaker,

b. The paralleling receptacles permit interconnection of the voltage regulator assemblies of two or more generator sets for parallel operation. They are part of the convenience and paralleling receptacles wiring harness.

##### 5-2. CONVENIENCE RECEPTACLE AND CIRCUIT BREAKER.

Refer to the Operator and Organizational Maintenance Manual for convenience receptacle and circuit breaker maintenance instructions.

##### 5-3. CONVENIENCE AND PARALLELING RECEPTACLES WIRING HARNESS.

a. Refer to the Operator and Organizational Maintenance Manual for convenience and paralleling receptacles wiring removal, cleaning, inspection, and repair instructions.

b. If the wiring harness has sustained damage and requires repair or rebuild, refer to figure 5-1 for layout, identification, and material requirements and Appendix A for detailed soldering and replacement procedures.

c. Refer to the Operator and Organizational Maintenance Manual for installation instructions for the wiring harness.

#### Section II. LOAD CONNECTION GROUP

##### 5-4. GENERAL.

a. The load connection group consists of the voltage reconnection board, the main load contactor, the load terminal board, and the current transformers.

b. The voltage reconnection board consists of a stationary terminal board and a movable link-type board. It provides a means of connecting the two coils of each phase of the generator assembly to provide all specified output voltages. Simultaneously, it reconnects all other circuits necessary to convert the generator set from 120/208 to 240/416 Vac operation.

c. The voltage reconnection board is connected to the load terminal board through a three-pole three-phase main load contactor. This contactor is controlled by the circuit breaker switch of the control cubicle assembly. The main load contacts will automatically open when any of the protective devices actuate or when the START-RUN-STOP switch is placed in the STOP position.

d. One lead of each of the two coils of each generator phase is connected directly to the voltage reconnection board. The remaining two leads of each

phase pass through a three-window current transformer. The proportional current induced in the transformer is used by the static exciter and voltage regulator assembly as a current boost. The leads then pass through a second three-window transformer. The proportional current induced in this transformer is used in the load measuring unit and the ammeter and watt-meter circuit of the control cubicle. The leads of two of the generator phases then pass through a single-window crosscurrent transformer. The current induced in the crosscurrent transformer is used for reactive power compensation during parallel operation. Local voltage sensing and adjustment are accomplished across a single coil of the remaining phase.

##### 5-5. VOLTAGE RECONNECTION BOARD ASSEMBLY

Refer to the Operator and Organizational Maintenance Manual for voltage reconnection board assembly removal, maintenance, and installation procedures.

##### 5-6. MAIN LOAD CONTACTOR.

###### a. Removal.

(1) Remove screws (1, figure 5-2), lockwashers (2), and flat washers (3) to remove terminal covers (4).

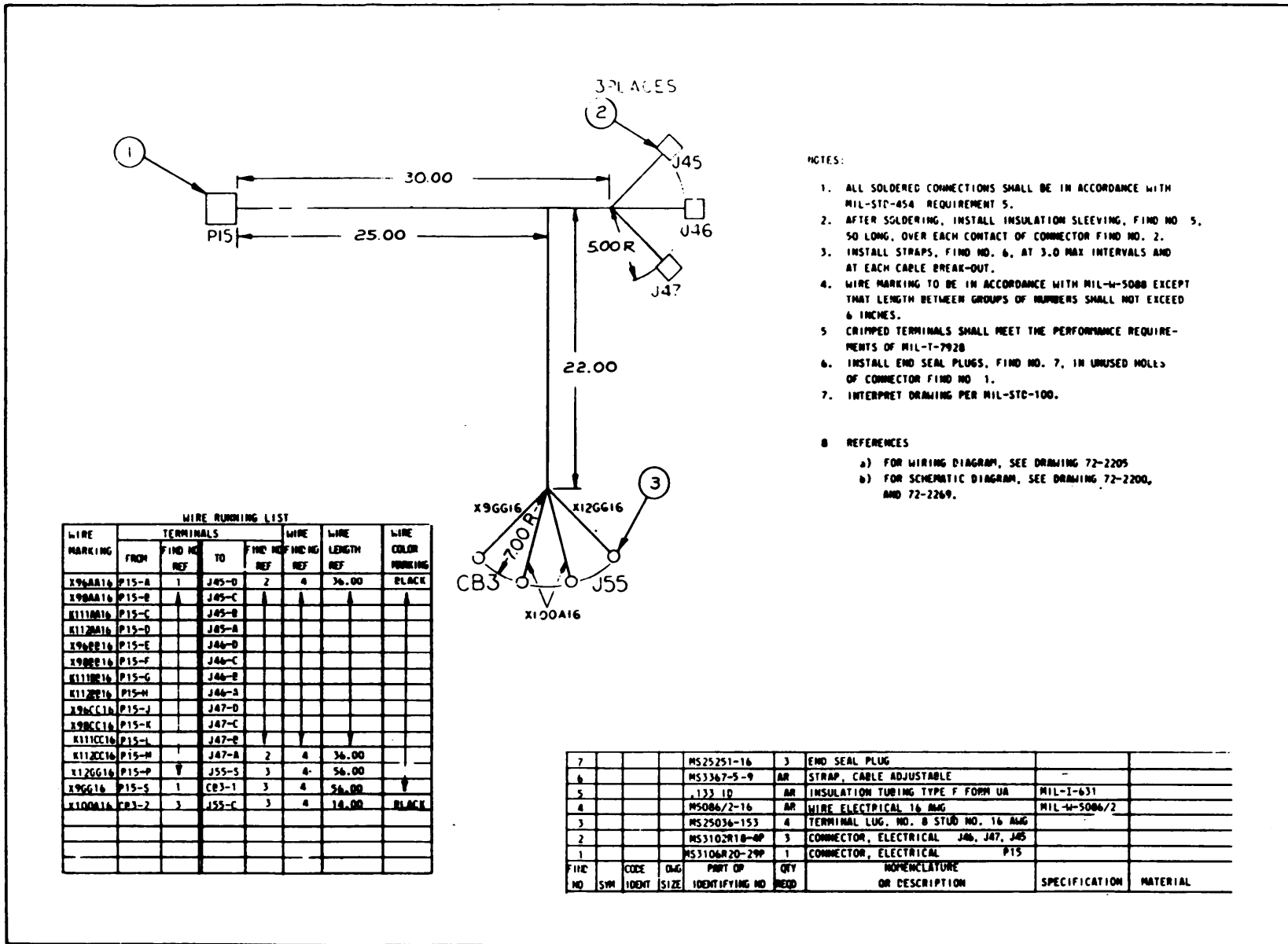

- NOTES:
1. ALL SOLDERED CONNECTIONS SHALL BE IN ACCORDANCE WITH MIL-STD-454 REQUIREMENT 5.
  2. AFTER SOLDERING, INSTALL INSULATION SLEEVING, FIND NO 5, 50 LONG, OVER EACH CONTACT OF CONNECTOR FIND NO. 2.
  3. INSTALL STRAPS, FIND NO. 6, AT 3.0 MAX INTERVALS AND AT EACH CABLE BREAK-OUT.
  4. WIRE MARKING TO BE IN ACCORDANCE WITH MIL-W-5000 EXCEPT THAT LENGTH BETWEEN GROUPS OF NUMBERS SHALL NOT EXCEED 6 INCHES.
  5. CRIPPED TERMINALS SHALL MEET THE PERFORMANCE REQUIREMENTS OF MIL-T-7920
  6. INSTALL END SEAL PLUGS, FIND NO. 7, IN UNUSED HOLES OF CONNECTOR FIND NO 1.
  7. INTERPRET DRAWING PER MIL-STD-100.

- REFERENCES
- a) FOR WIRING DIAGRAM, SEE DRAWING 72-2205
  - b) FOR SCHEMATIC DIAGRAM, SEE DRAWING 72-2200, AND 72-2269.

WIRE RUNNING LIST							
WIRE MARKING	TERMINALS		WIRE		WIRE LENGTH REF	WIRE COLOR MARKING	
	FROM	FIND NO REF	TO	FIND NO REF			
X96AA16	P15-A	1	J45-D	2	4	36.00	BLACK
X98AA16	P15-B		J45-C				
K111AA16	P15-C		J45-B				
K112AA16	P15-D		J45-A				
X96BB16	P15-E		J46-D				
X98BB16	P15-F		J46-C				
K111BB16	P15-G		J46-B				
K112BB16	P15-H		J46-A				
X96CC16	P15-J		J47-D				
X98CC16	P15-K		J47-C				
K111CC16	P15-L		J47-B				
K112CC16	P15-M		J47-A	2	4	36.00	
X12GG16	P15-P		J55-S	3	4	56.00	
X9GG16	P15-S	1	CB3-1	3	4	56.00	
X100A16	CB3-2	3	J55-C	3	4	18.00	BLACK

7			MS25251-16	3	END SEAL PLUG			
6			MS3367-5-9	AR	STRAP, CABLE ADJUSTABLE			
5			.133 ID	AR	INSULATION TUBING TYPE F FORM UA	MIL-I-631		
4			MS5086/2-16	AR	WIRE ELECTRICAL 16 AWG	MIL-W-5006/2		
3			MS25036-153	4	TERMINAL LUG, NO. 8 STUD NO. 16 AWG			
2			MS3102R10-0P	3	CONNECTOR, ELECTRICAL J46, J47, J45			
1			MS3106R20-29P	1	CONNECTOR, ELECTRICAL P15			
FIND NO	SYM	CODE IDENT	QNG SIZE	PART OP IDENTIFYING NO	QTY REQD	NOMENCLATURE OR DESCRIPTION	SPECIFICATION	MATERIAL

Figure 5-1. Convenience and Paralleling Receptacles Wiring Harness, Drawing No. 72-2286

ME 5-6115-465-34/5-1

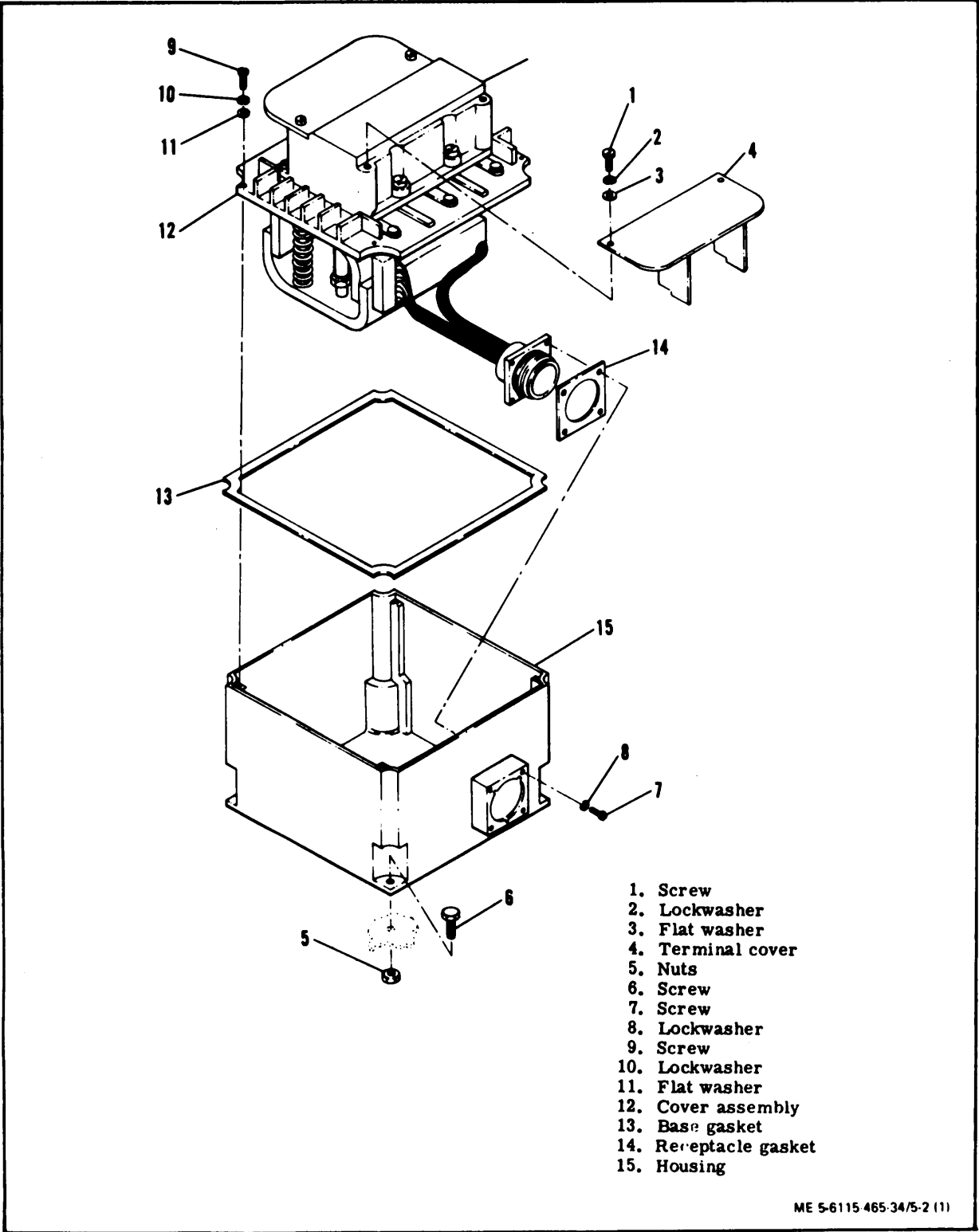

Figure 5-2. Main Load Contactor, Exploded View (Sheet 1 of 3)

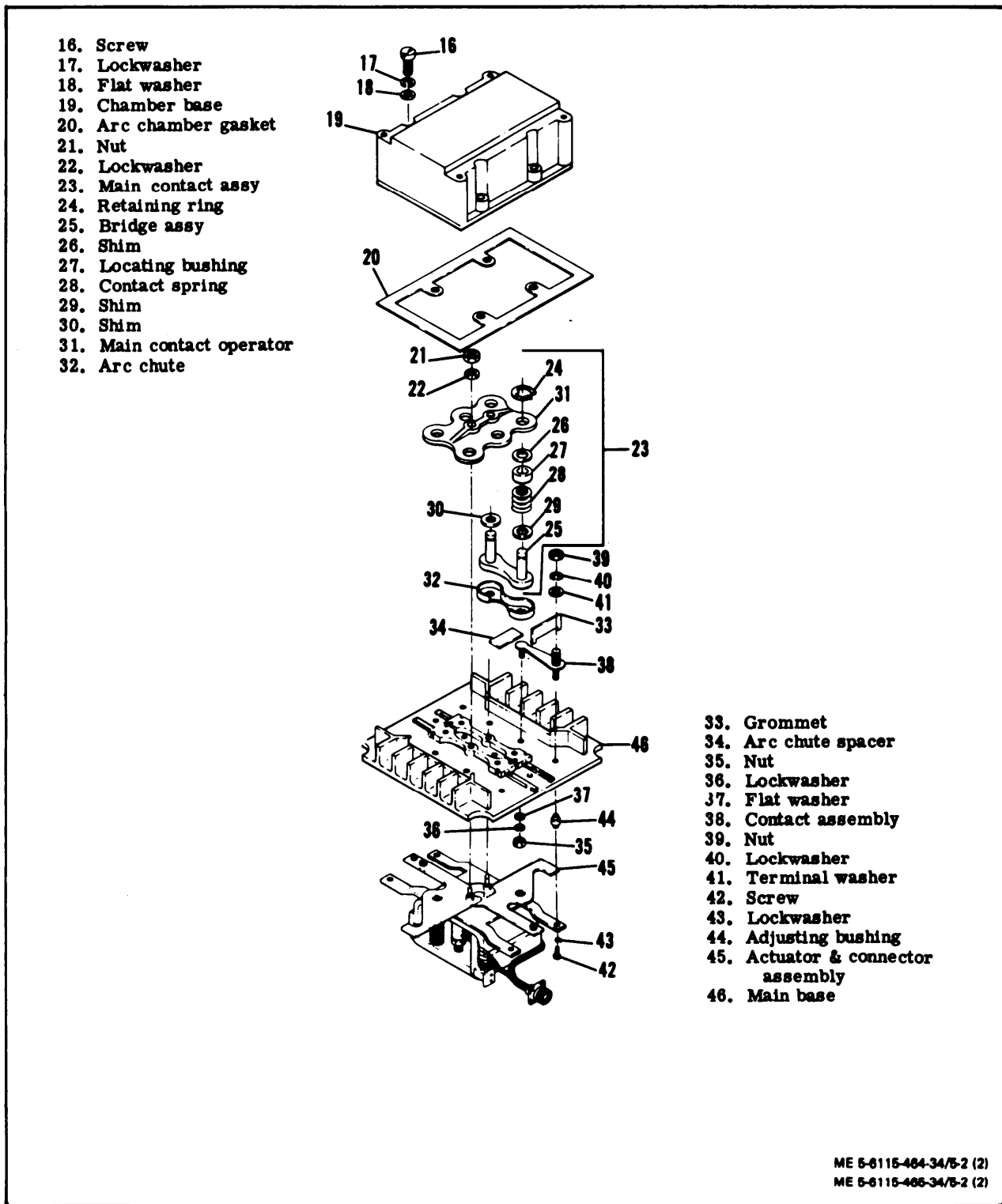

Figure 5-2. Main Load Contactor, Exploded View (Sheet 2 of 3)

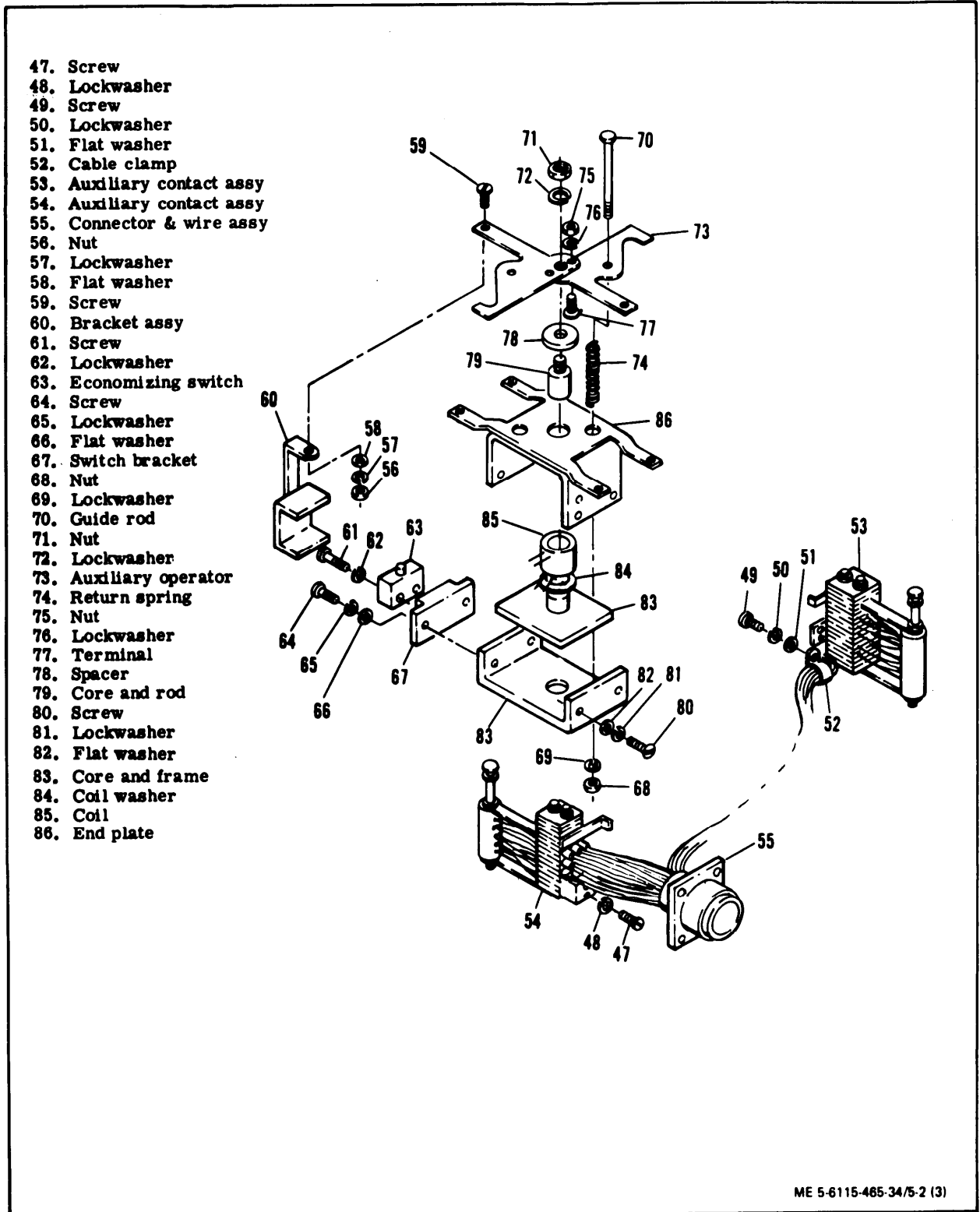

Figure 5-2. Main Load Contactor, Exploded View (Sheet 3 of 3)

(2) Tag and disconnect electrical leads to terminals.

(3) Disconnect wiring harness connector from main load contactor connector.

(4) Remove nuts (5) and screws (6) to remove main load contactor.

b. Disassembly.

(1) Thoroughly clean the exterior of the contactor with a clean, lint-free cloth moistened with an approved solvent. Blow dust and dirt from crevices with compressed air.

(2) Disassemble main bad contactor in order of the ascending sequence of index numbers (7 thru 86) assigned to figure 5-2.

c. Cleaning, Inspection, and Repair.

(1) Clean all parts with a clean, lint-free cloth moistened with an approved solvent.

(2) Check terminal covers (4) and housing (15) for cracks, breaks, and other damage.

(3) Inspect chamber base (19), main base (46), and main contact operator (31) for cracks, breaks, and other damage.

(4) Inspect bridge assembly (25) for pitting, corrosion, and other damage.

(5) Inspect contact assembly (38) for burns, corrosion, melting and other damage.

(6) Inspect auxiliary operator (73) for cracks,

(7) Check core and rod (79), core and frame (83), bracket assembly (60), and end plate (86) for cracks, breaks, and other damage.

(8) Check coil (85) for swelling of encapsulated material, burns, and evidence of corrosion. Using an ohmmeter, check coil for continuity.

(9) Check economizing switch (63) for cracks, corrosion, burns, and evidence of shorting.

(10) Check contacts of contact assemblies (53 and 54) for corrosion, pitting, burns, and other damage.

(11) Check connector and wire assembly for cracks, stripped or otherwise damaged threads, burned or chafed insulation, bare wires and other damage. Refer to Appendix A references to solder or repair wire and connector damage.

(12) Check all threads for crossing, stripping, peening, and other damage.

(13) Discard gaskets (20, 14, and 13) and spacer (78).

(14) Repair minor thread damage to parts using thread chaser. Discard hardware with thread damage.

(15) Remove minor pitting from contact surfaces of bridge assemblies with fine grit abrasive paper or a fine file. Replace bridge assemblies if deeply pitted.

(16) Replace any parts found defective or damaged beyond repair.

d. Assembly.

(1) Assemble core and frame (83), coil washer (84), and coil (85).

(2) Install end plate (86) and loosely install flat washers (82), lockwashers (81) and screws (60).

(3) Secure terminals (77) to auxiliary operator (73) with lockwashers (76) and nuts (75).

(4) Install adhesive back spacer (78) (adhesive side up) over core and rod (79).

(5) Secure core and rod to auxiliary Operator with nut (71) and lockwasher (72).

(6) Insert guide rods (70) through auxiliary operator (73) and install return springs (74).

(7) Thread guide rods into core and frame (83) until a sufficient length extends out the bottom to loosely install lockwashers (69) and nuts (68).

(8) Install the economizing switch (63) onto bracket (67) and secure with lockwashers (62) and screws (61).

(9) Loosely secure bracket (67) to core and frame (83) with flat washers (66), lockwashers (65) and screws (64).

(10) Fit bracket (60) over economizing switch and secure to auxiliary operator (73) with screw (59), flat washer (58), lockwasher (57), and nut (56).

(11) Adjust assembled actuator assembly as follows: (see figure 5-3. )

(a) Install a suitable clamp across points (A) and (B) of actuator assembly. Tighten clamp sufficiently to insure that no air gap exists at points (C) and (D).

(b) Tighten loosely installed screws (I).

(c) Remove clamp.

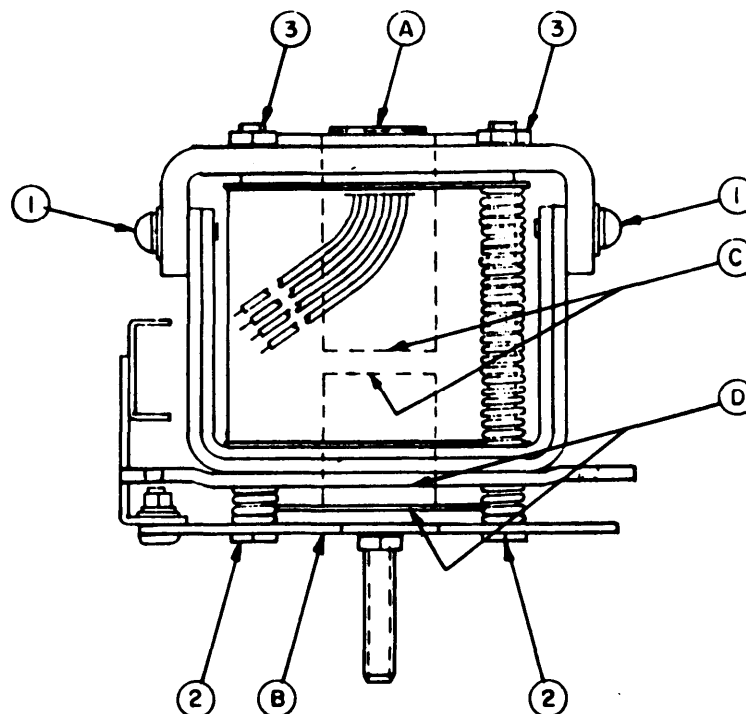

ME 5-6115-465-34/5-3

Figure 5-3. Actuator Assembly Adjustment Points

(d) Insert a  $0.150 \pm 0.010$  inch feeler gauge into the movable core gap.

(e) Adjust guide rods (2) until the gauge is snug throughout the perimeter.

(f) Secure the adjustment by tightening loosely installed nuts (3).

(12) Install contact assemblies (54 and 53, figure 5-2) and cable clamp (52) and secure with flat washer (51), lockwasher (50), screw (49), lockwashers (46), and screws (47).

(13) Secure contact assemblies (38) to main base (46) with flat washers (37), lockwashers (36), and nuts (35). Install terminal washers (41), lockwashers (40) and nuts (39).

(14) Install grommets (33), spacers (34), and arc chutes (32).

(15) Install shims (30 and 29), springs (28), bushings (27), and shims (26) onto bridge assemblies (25). Secure bridge assemblies to main contact operator (31) with retaining rings (24).

(16) Check preload of each contact as follows: (See figure 5-4. )

NOTE

Preload is checked by the initial break-away of retaining ring (point (B)).

(a) Using a force gauge, check each individual contact at its edge (point (A)). Preload should be 1.5 to 205 pounds.

(b) If preload is not as specified, add or subtract shims (26, 29, and 30, figure 5-2).

(17) Install actuator and connector assembly (45, figure 5-2) onto main base (46) and secure with bushing (44), lockwashers (43) and screws (42).

(18) Install main contact assembly (23) and secure with lockwashers (22) and nuts (21). Adjust contact over travel as follows: (See figure 5-5. )

(a) Attach an ohmmeter to terminals A1-A2 and C1-C2.

(b) Insert a 0.035 inch feeler gauge into core gap (point (A)).

(c) Energize coil by applying 24 Vdc across connector pins A and B (see figure 5-6).

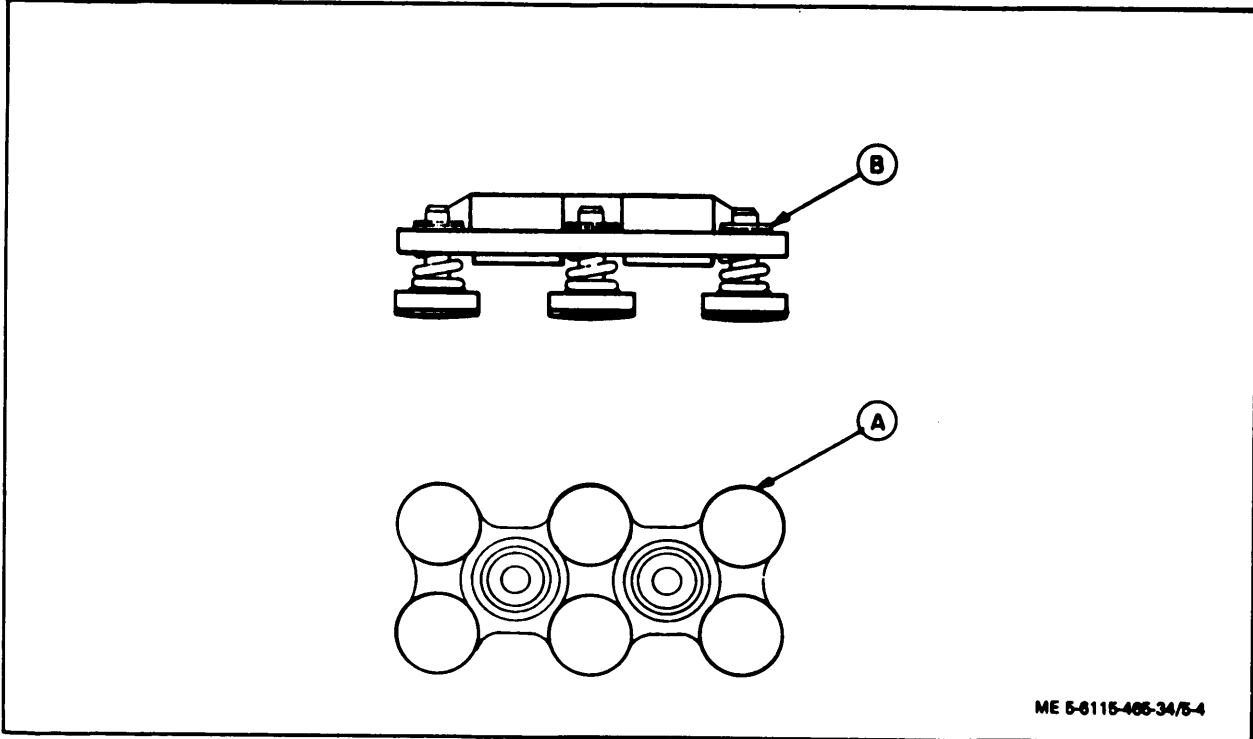

Figure 5-4. Main Contact Preload Check Points

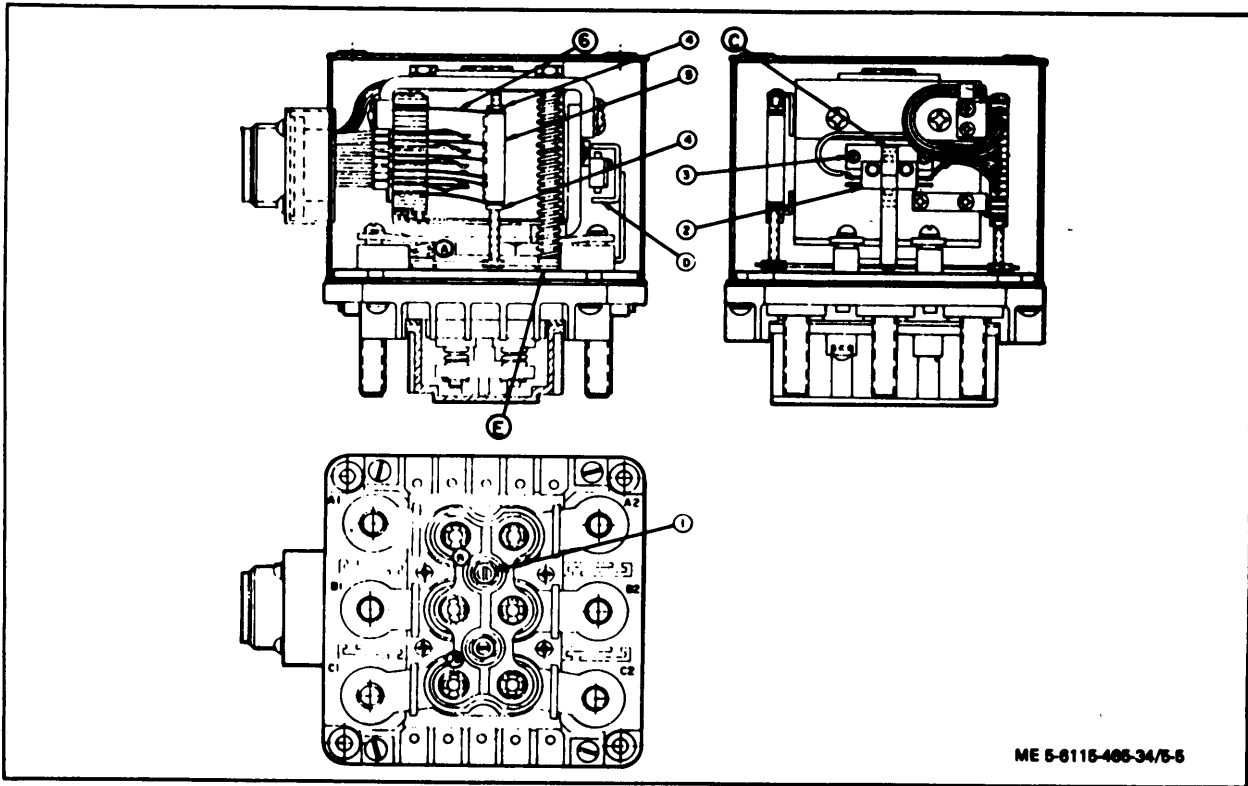

Figure 5-5. Main Load Contactor Adjustments



(d) Adjust carrier bushing at point (B) (figure 5-5) until continuity is indicated at terminals A1-A2 and C1-C2.

(e) Secure adjustment by tightening nuts (l).

(f) Recheck for continuity at a clearance of 0.035 inch and for open circuit at 0.040 inch.

(19) Adjust economizing switch as follows: (see figure 5-5.)

(a) Move loosely installed bracket (3) to transfer switch.

(b) Check that the switch button is fully depressed, and allow 0.010 inch clearance between the switch button and the top operator (point (C)).

(c) Insert a 0.010 inch feeler gauge into the core gap (point (A)).

(d) Apply 24 Vdc to connector pins A and B (see figure 5-6).

(e) Bend the tab (point D, figure 5-5) of bracket toward the switch until the switch actuates.

(f) Remove 24 Vdc, and then apply again to insure that the switch actuates properly.

(g) Remove 24 Vdc and replace 0.010 inch feeler gauge with 0.018 inch feeler gauge.

(h) Apply 24 Vdc again to check that the switch does not transfer.

(i) Readjust if necessary.

(20) Adjust auxiliary contacts as follows: (see figure 5-5.)

(a) Loosen nuts (4) and position lift comb (5) so that the deflection on the guide leaf springs (6) is nearly equal in the energized and de-energized positions.

(b) Secure adjustment by tightening nuts (4).

(c) Insert a 0.018 inch feeler gauge between the guide rod head and the operator (point E).

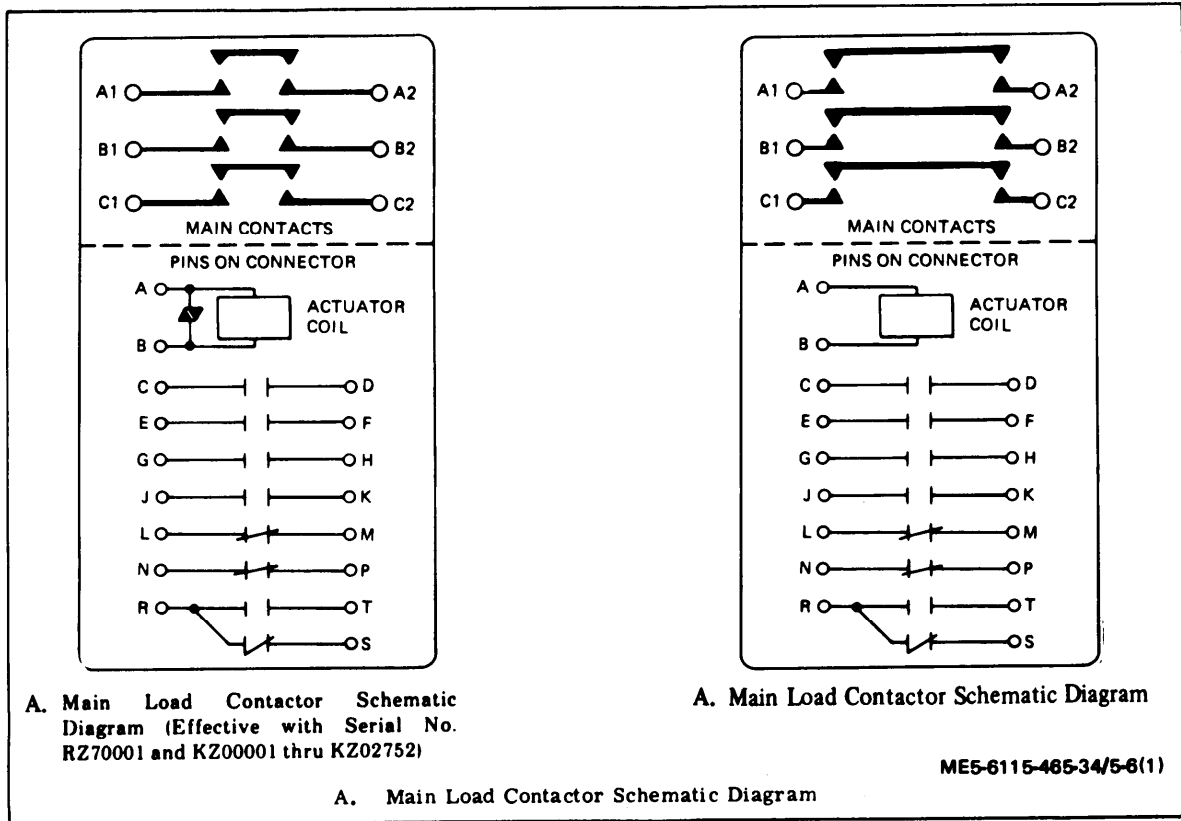
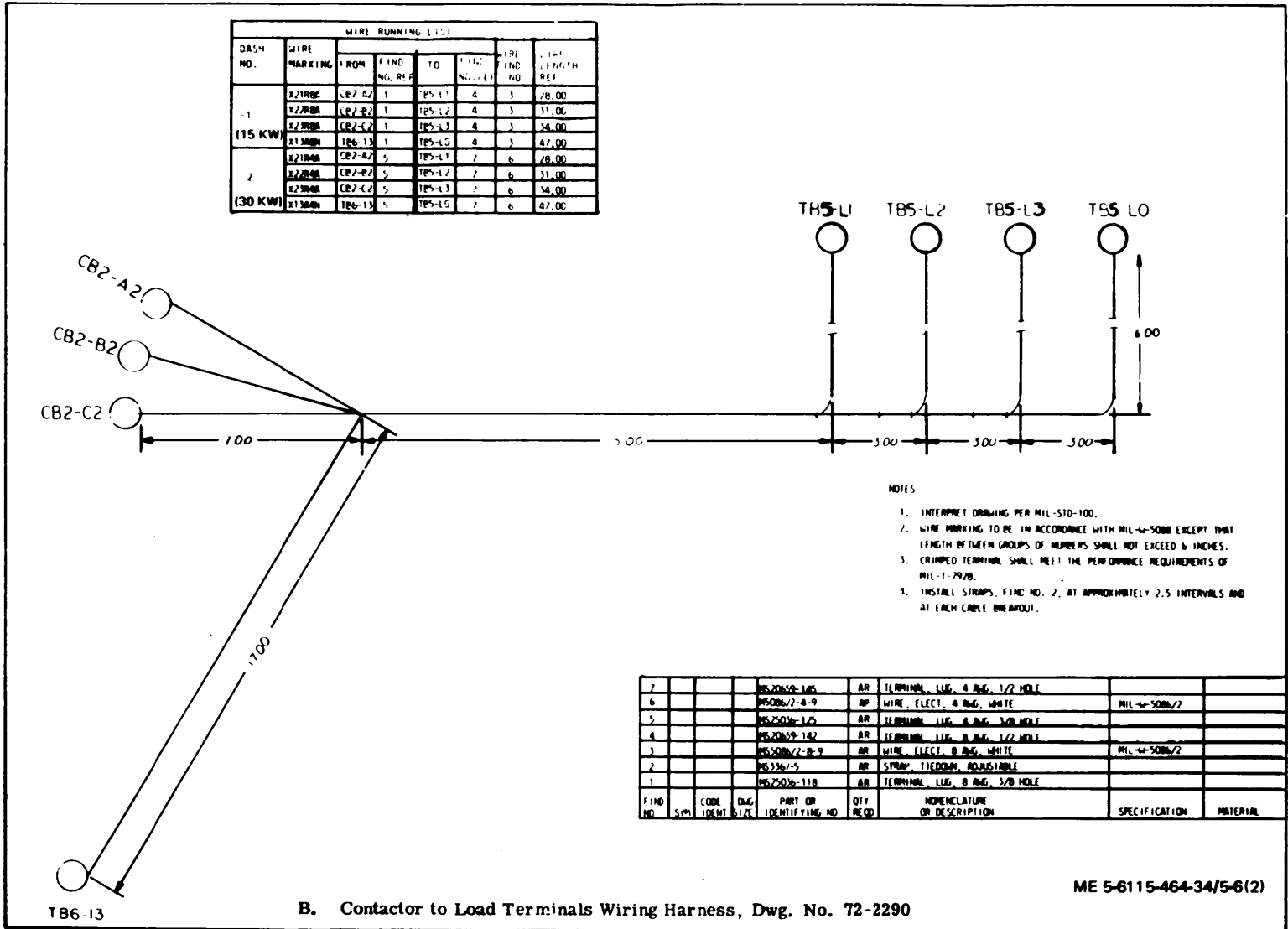

Figure 5-6. Main Load Contactor Schematic Diagram, Contactor to Load Terminals Wiring Harness, Dwg. No: 72-2290, and Contactor to Reconnection Board Wiring Harness, Dwg. No. 72-2225 (Sheet 1 of 3)



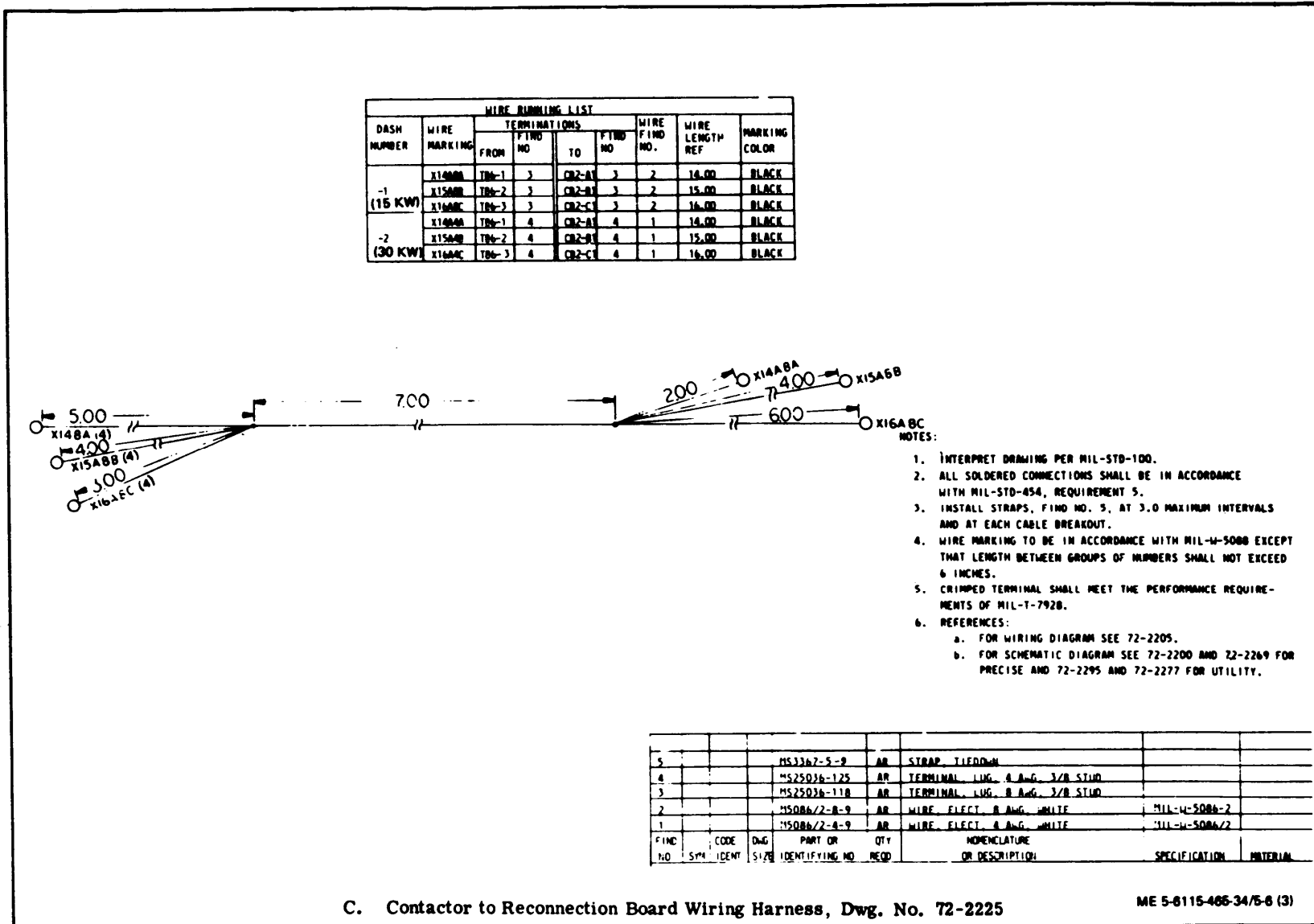

Figure 5-6. Main Load Contactor Schematic Diagram, Contactor to Load Terminals Wiring Harness, Dwg. No. 72-2290, and Contactor to Reconnection Board Wiring Harness, Dwg. No. 72-2225 (Sheet 3 of 3)

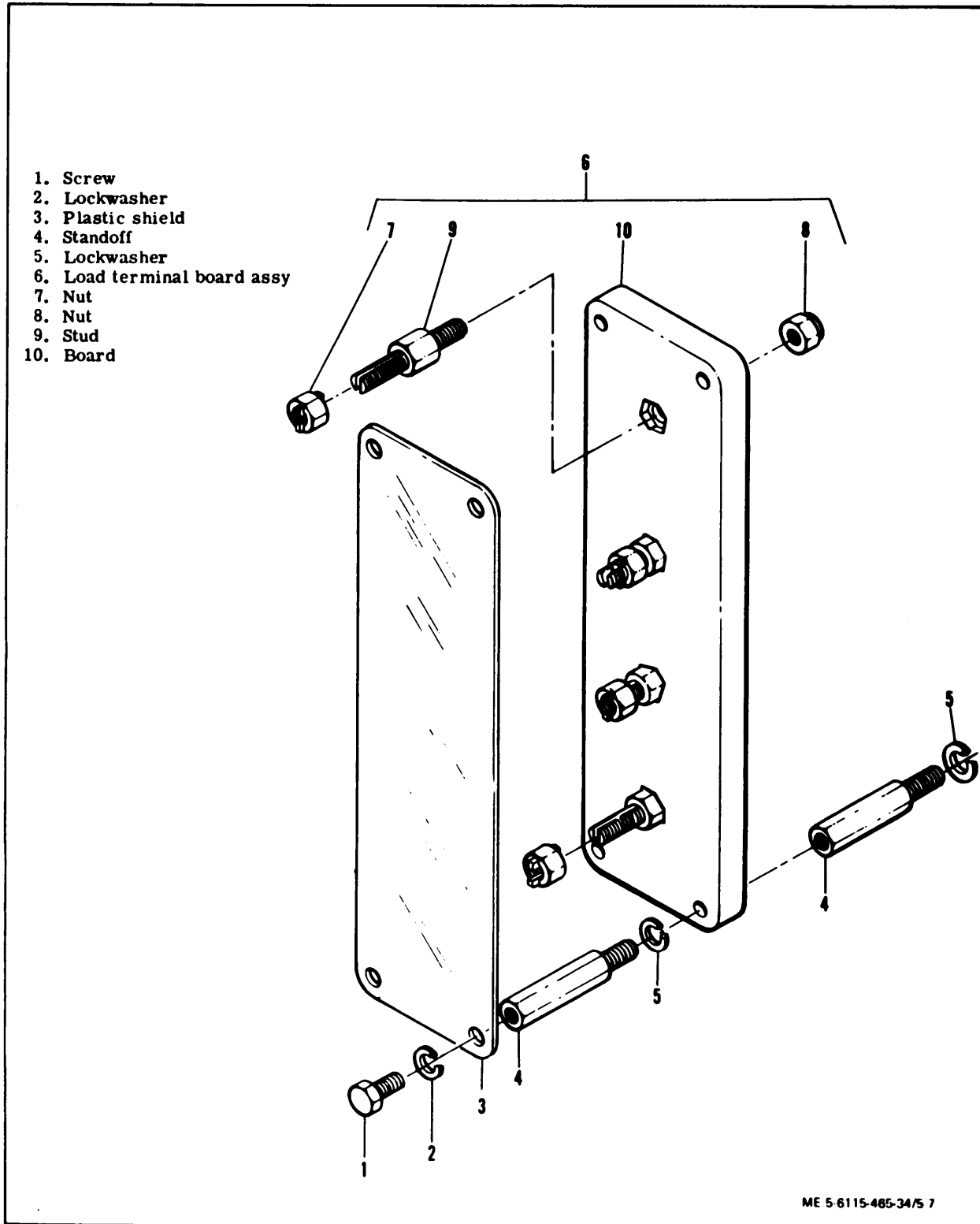

Figure 5-7. Load Terminal Board Assembly, Exploded View

(d) Apply 24 Vdc to connector pins A and B (see figure 5-6).

(e) Bend the tab (point D, figure 5-5) of bracket toward the switch until the switch actuates.

(f) Remove 24 Vdc, and then apply again to insure that the switch actuates properly.

(g) Remove 24 Vdc and replace 0.010 inch feeler gauge with 0.018 inch feeler gauge.

(h) Apply 24 Vdc again to check that the switch does not transfer.

(i) Readjust if necessary.

(20) Adjust auxiliary contacts as follows: (see figure 5-5.)

(a) Loosen nuts (4) and position lift comb (5) so that the deflection on the guide leaf springs (6) is nearly equal in the energized and de-energized positions.

(b) Secure adjustment by tightening nuts (4).

(c) Insert a 0.018 inch feeler gauge between the guide rod head and the operator (point E).

(d) Using an ohmmeter to determine continuity, adjust the stationary contacts of the normally closed contacts until they just touch the movable contacts (see figure 5-6 for contact positions).

(e) Replace the 0.018 inch feeler gauge with a 0.025 inch feeler gauge and recheck for open circuit of normally closed contacts. Readjust if necessary.

(f) The normally open contacts are adjusted the same as the normally closed contacts except that shims are inserted into the core gap (point A).

(21) Install chamber base (19, figure 5-2) and gasket (20) and secure with flat washers (18), lockwashers (17) and screws (16).

(22) Install cover assembly (12) with receptacle gasket (14) and base gasket (13) onto housing (15) and secure with flat washers (11), lockwashers (10), screws (9), lockwashers (8), and screws (7).

e. Installation. Install main load contactor in reverse order of removal procedures.

5-6.1. MAINLOAD CONTACTOR (Effective with Serial Number RZ70001 and KZ00001 thru KZ02752).

a. Removal.

(1) Remove screws (1, Figure 5-7A), lockwashers (2) and flat washers (3) to remove terminal covers (4). Remove nuts (5), lockwashers (6) and flat washers (7).

(2) Tag and disconnect electrical leads to terminals.

(3) Disconnect wiring harness connector from main load contactor connector.

(4) Remove nuts (8) and screws (9) to remove main load contactor.

b. Disassembly.

(1) Thoroughly clean the exterior of the contactor with a clean, lint-free cloth moistened with an approved solvent, Blow dust and dirt from crevices with compressed air.

(2) Remove locking spacers (20), lockwashers (11) and flat washers (12) to remove contact chamber (13) and gasket (14).

(3) Remove spacers (25) arc chutes (16), nuts (17), lockwashers (18), flat washers (19), bushings (20), springs (21), bridge assemblies (22), bushings (23) and washers (24).

(4) Remove spacers (25), screws (26), screws (27), lockwashers (28), flat washers (29) to remove base assembly (30), gasket (31) and insulation (32).

(5) Remove screws (33), screws (34) and lockwashers (35) and remove solenoid assembly (36) from cover assembly (37). Remove gasket (38).

(6) Remove screws (39) and lockwashers (40) and remove switches (41) and connector (42) as an assembly.

(7) Remove screws (43) and lockwashers (44) to remove switch operators (45). Remove nuts (46), lockwashers (47) and screws (48) from operators (45).

(8) Remove screws (49) to remove end frame (50), spring (51) and core and rod assembly (52).

(9) Remove screws (53), frame and spacer (54), screws (55), micro switch (56) and frame and spacer (57).

(10) Remove frame and core assembly (58) and washer (59) from coil assembly (60).

c. Cleaning, Inspection and Repair.

(1) Clean all parts with a clean lint-free cloth moistened with an approved solvent.

(2) Check terminal covers (4) and cover assembly (37) for cracks, breaks and other damage.

(3) Inspect contact chamber (13) and base assembly (30) for cracks, breaks and other damage.

(4) Inspect bridge assembly (22) for pitting, corrosion, and other damage.

(5) Check core assembly (58), rod assembly (52), frame and spacers (54 and 57), and end frame (50) for cracks, breaks and other damage.

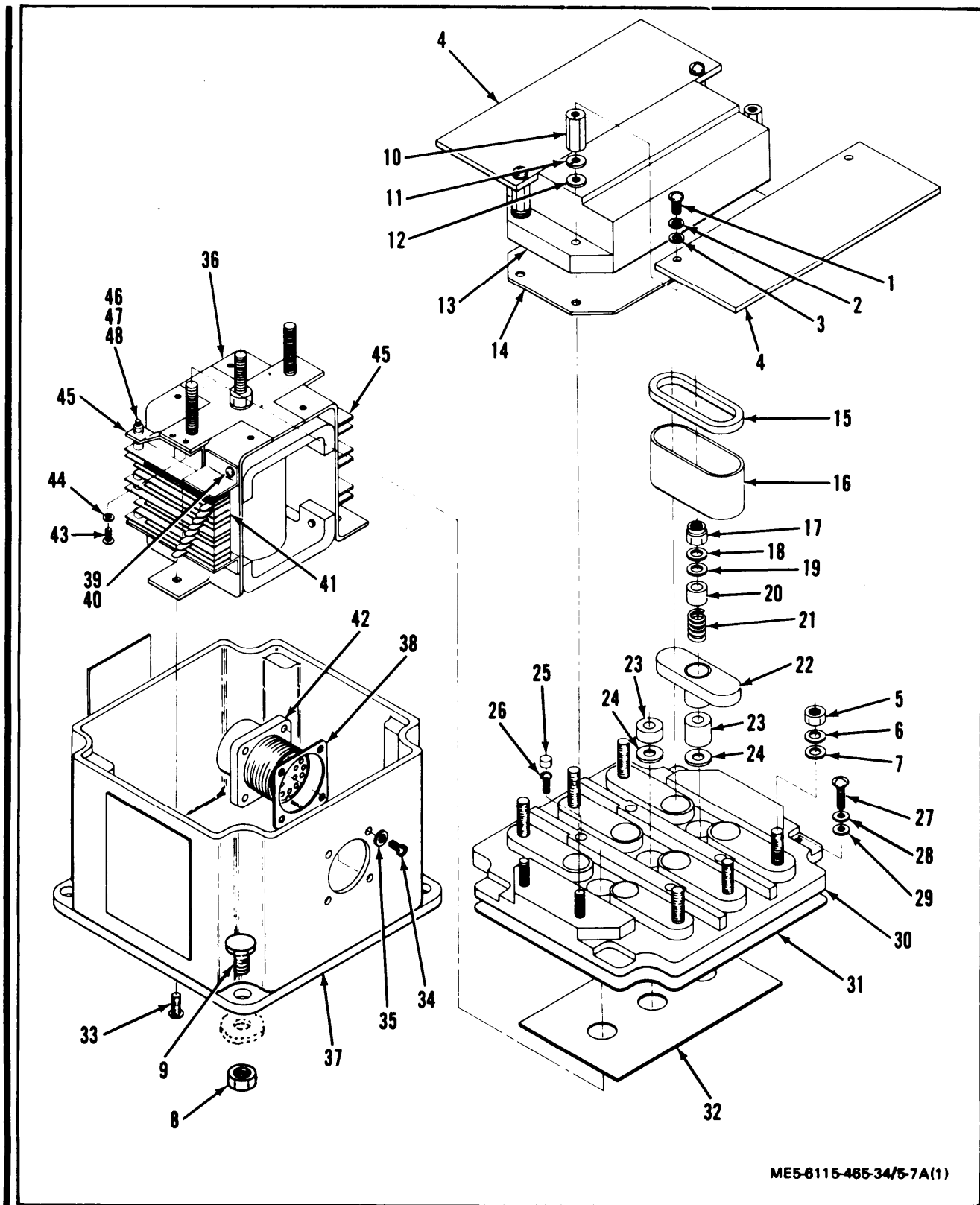

ME5-6115-465-34/5-7A(1)

Figure 5-7.1. Main Load Contact, Exploded View (Effective with Serial No. RZ70001 and KZ00001 thru KZ02752) (Sheet 1 of 3)

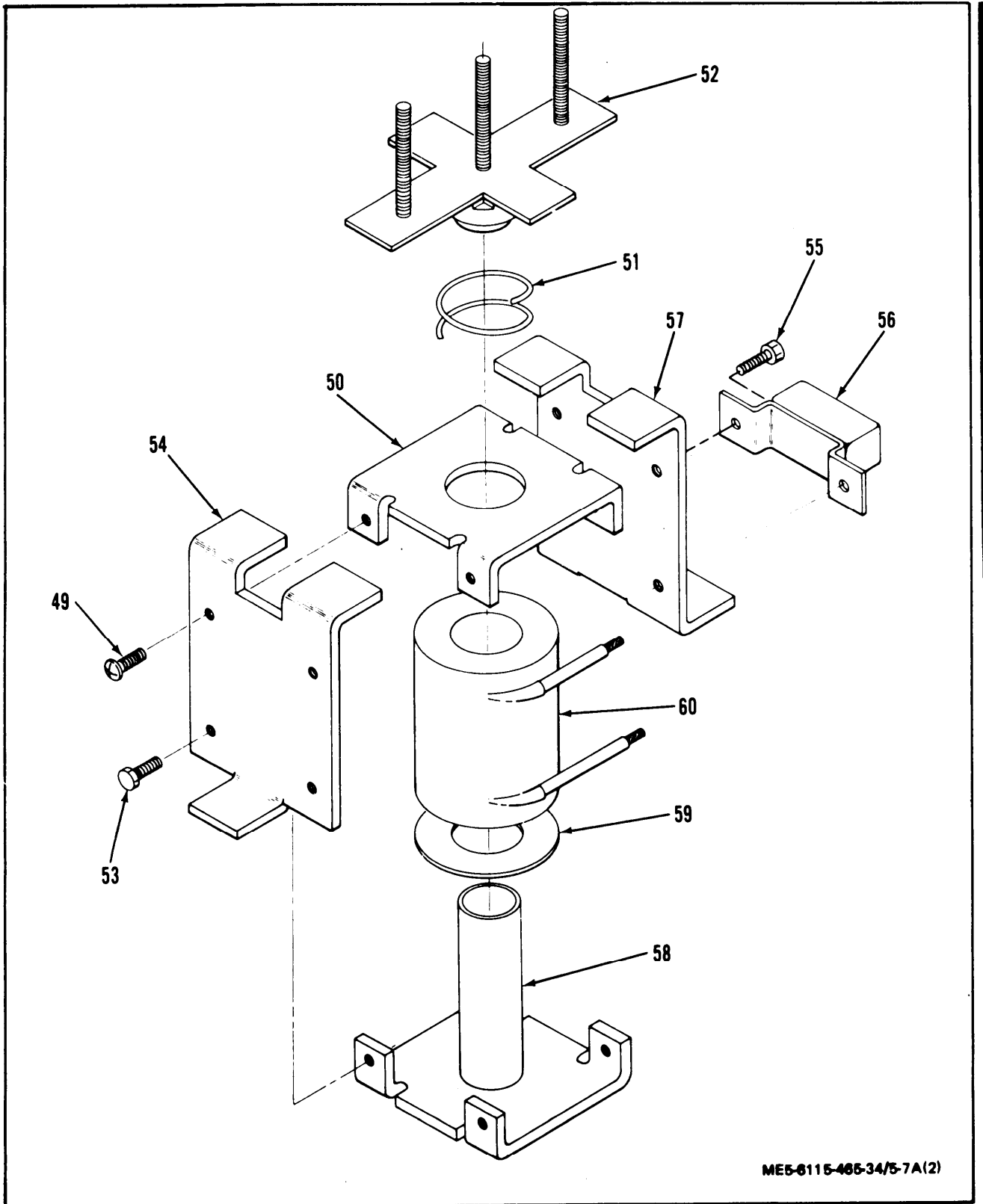

ME5-6115-465-34/5-7A(2)

Figure 5.7.1. Main Load Contactor, Exploded View (Effective with Serial No. RZ70001 and KZ00001 thru KZ02752) (Sheet 2 of 3)

- |                     |                       |
|---------------------|-----------------------|
| 1. Screw            | 31. Gasket            |
| 2. Lockwasher       | 32. Insulation        |
| 3. Flat Washer      | 33. Screw             |
| 4. Terminal Cover   | 34. Screw             |
| 5. Nut              | 35. Lockwasher        |
| 6. Lockwasher       | 36. Solenoid Assembly |
| 7. Flat Washer      | 37. Cover Assembly    |
| 8. Nut              | 38. Gasket            |
| 9. Screw            | 39. Screw             |
| 10. Spacer          | 40. Lockwasher        |
| 11. Lockwasher      | 41. Switch            |
| 12. Flat Washer     | 42. Connector         |
| 13. Contact Chamber | 43. Screw             |
| 14. Gasket          | 44. Lockwasher        |
| 15. Spacer          | 45. Switch Operator   |
| 16. Arc Chute       | 46. Nut               |
| 17. Nut             | 47. Lockwasher        |
| 18. Lockwasher      | 48. Screw             |
| 19. Flat Washer     | 49. Screw             |
| 20. Bushing         | 50. End Frame         |
| 21. Spring          | 51. Spring            |
| 22. Bridge Assembly | 52. Rod Assembly      |
| 23. Bushing         | 53. Screw             |
| 24. Washer          | 54. Spacer            |
| 25. Spacer          | 55. Screw             |
| 26. Screw           | 56. Micro Switch      |
| 27. Screw           | 57. End Frame         |
| 28. Lock washer     | 58. Core Assembly     |
| 29. Flat Washer     | 59. Washer            |
| 30. Base Assembly   | 60. Coil Assembly     |

ME5-6115-465-34/5-7A(3)

Figure 5-7.1. Main Load Contactor Exploded View (Effective with Serial No. RZ70001 and KZ00001 thru KZ02752) (Sheet 3 of 3)



(6) Check coil assembly (60) for swelling of encapsulated material, burns, and evidence of corrosion. Using an ohmmeter, check coil for continuity.

(7) Check micro-switch (56) for cracks, corrosion, burns, and evidence of shorting.

(8) Check contacts of switches (41) for corrosion, pitting, burns and other damage.

(9) Check connector (42) and wiring for cracks, stripped or otherwise damaged threads, burned or chaffed insulation, bare wires and other damage. Refer to Appendix A to solder or repair wire and connector damage.

(10) Check all threads for crossing, stripping, peening and other damage.

(11) Discard gaskets (14,31 and 38), insulation (32), and washer (59).

(12) Repair minor thread damage to parts using thread chaser. Discard hardware with thread damage.

(13) Remove minor pitting from contact surfaces of bridge assemblies (22) with fine grit abrasive paper or a fine file. Replace bridge assemblies if deeply pitted.

(14) Replace any parts found defective or damaged beyond repair.

d. Assembly.

(1) Assemble main load contactor in reverse of disassembly.

(2) Torque screws (49 and 53) to 30 inch pounds.

5-7. LOAD TERMINAL BOARD ASSEMBLY.

a. Removal.

WARNING

Lethal voltages are present at the load terminal board when the generator set is in operation. Do not attempt to perform maintenance on the load terminal board while the generator set is in operation. Serious electrical shock or death may result from failure to observe this warning.

(1) Tag and disconnect electrical leads to load terminal board assembly.

(2) Remove screws (1, figure 5-7), lockwashers (2) and plastic shield (3).

(3) Remove stand-off (4) and lockwashers (5) to remove load connection terminal board assembly (6).

b. Disassembly. Disassemble load terminal board (items

7 through 10, figure 5-7) only as required to replace defective parts during inspection procedures.

c. Cleaning, Inspection, and Repair.

(1) Clean load terminal board with filtered compressed air and a soft bristle brush.

(2) If necessary, wipe load terminal board assembly with a clean, lint-free cloth moistened with an approved solvent.

(3) Inspect load terminal board for warping, cracks, damaged threads, corroded terminals, and burns.

(4) Replace any damaged or defective parts.

d. Installation. Install load terminal board assembly in reverse order of removal procedures.

5-8. CURRENT TRANSFORMER ASSEMBLIES.

a. Removal.

(1) Tag and disconnect electrical leads from transformer winding terminals.

(2) Tag generator leads and record their routing through transformer windows (noting polarity) as shown in figure 5-8; then disconnect and remove them.

(3) Remove nuts (1, figure 5-9), lockwashers (2), screws (3) and current boost transformer (4).

(4) Do not remove screw and washer assemblies (5), flat washers (6) and mounting brackets (7) unless inspection reveals damage and replacement is necessary.

(5) Remove screw and washer assemblies (8), flat washers (9) and instrumentation transformer (10).

(6) Remove nuts (1), screws (12), lockwashers (13), and cross-current compensation transformer (14).

(7) Do not remove screw and washer assemblies (15), flat washers (16) and mounting brackets (17) unless inspection reveals damage and replacement is necessary.

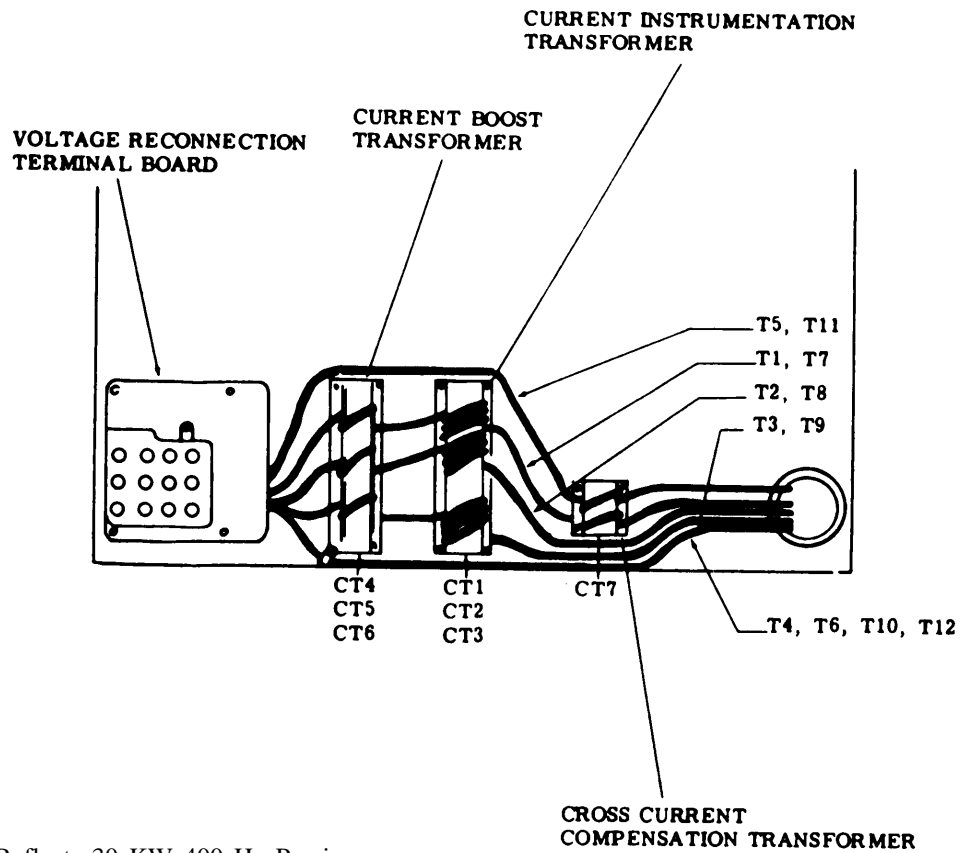

NOTE 1. Drawing Reflects 30 KW 400 Hz Precise.

NOTE 2. On 30 KW 50/60 Hz Precise and Utility Set,  
leads T5 and T11 are routed the same as T4, T6,  
T10 and T12.

Figure 5-8. Routing of Generator Leads Through Current Transformers.

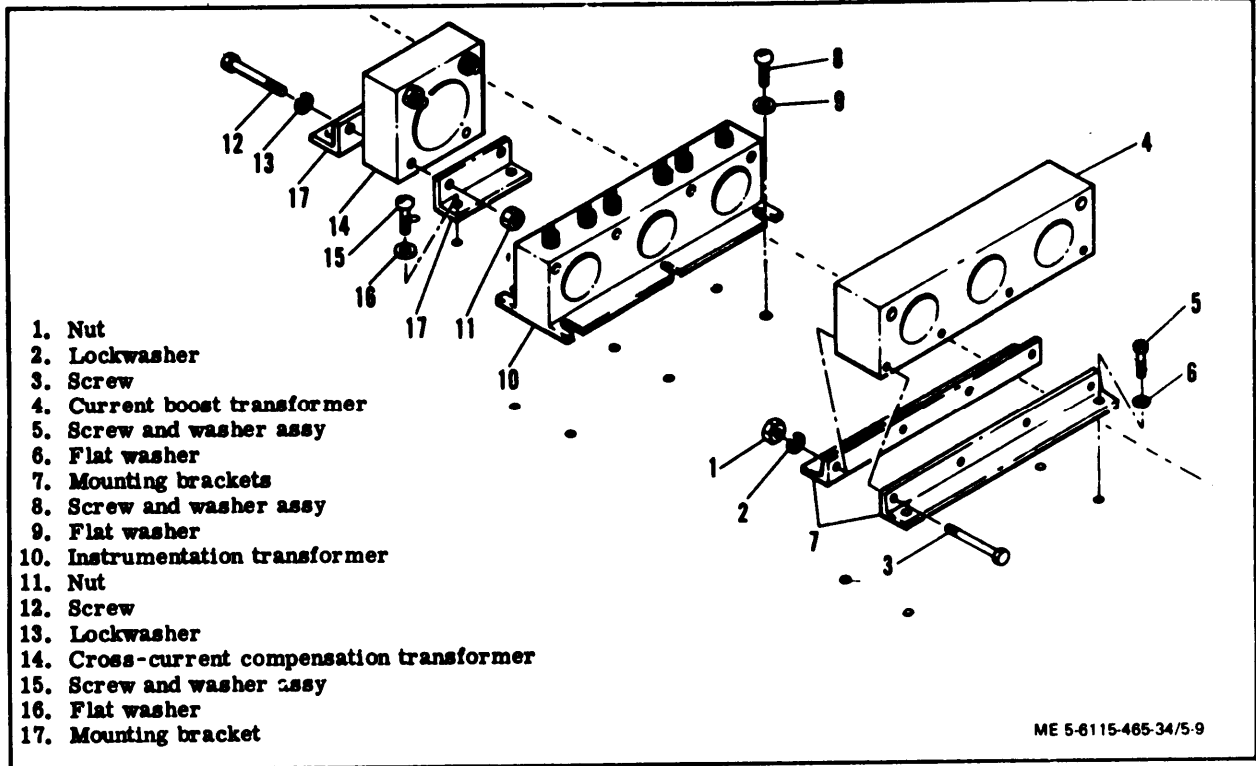

Figure 5-9. Transformer assemblies, Removal and Installation

b. = Cleaning, Inspection, and Testing.

(1) Clean transformer assemblies with a clean, lint-free cloth moistened with an approved solvent and dry thoroughly.

(2) Inspect transformer assemblies for cracks, corroded terminals, and evidence of shorting.

(3) Test current boost transformer as follows:

(a) Using an ohmmeter, check resistance between terminals A1 and A2, B1 and B2, and C1 and C2, figure 5-10. Resistance shall be 0.19 ohm in each case.

(b) Apply 7V-60 Hz to secondary winding. Excitation current shall be 0.075 amp (maximum).

(4) Test instrumentation transformer as follows:

(a) Using an ohmmeter, check resistance between terminal A1 and A2, B1 and B2, C1 and C2 (figure 5-10b). Resistance shall be 0.11 ohm in each case.

(b) Apply 10V-60 Hz to secondary winding. Excitation current shall be 0.050 amp (maximum).

(5) Test cross-current compensation transformer as follows:

(a) Using an ohmmeter, check resistance between terminals. Resistance shall be 0.3 ohm.

(b) Apply 10V-60 Hz to secondary winding. Excitation current shall be 0.050 amp (maximum).

(6) Replace defective or damaged transformers.

c. Installation. Install transformer assemblies in reverse order of removal procedures.

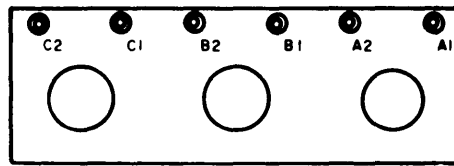

a. Current boost transformer

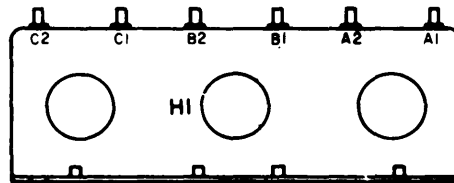
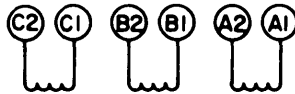

b. Instrumentation transformer

ME 5-6115-465-34/5-10

Figure 5-10. Current Transformer Test Point

Section III. RELAY TABLE COMPONENTS

5-9. GENERAL.

The relay table components consist of the tactical relay assembly, the special relay assembly, and the precise relay assembly. The tactical relay assembly, which is common to all three models, contains relays to shutdown the generator set in the event of over voltage, short circuit, over load, and reverse power. It also houses the current transformer load resistors. The special relay assembly, also common to all three models, contains the relays for the remainder of the protective devices and the paralleling controls for the voltage regulator. The precise relay assembly is used only on the 50/60 Hz and 400 Hz precise models. It contains the paralleling controls for the governor control unit and the fixed resistors of the frequency adjustment system. The 50/60 Hz model of the precise relay assembly also contains a frequency selector switch which changes its operation from 50 to 60 Hz.

5-10. TACTICAL RELAY ASSEMBLY.

WARNING

Do not attempt to perform maintenance on the tactical relay assembly while the generator set is operating. Severe electrical shock or death may result from failure to observe this warning.

a. Removal.

(1) Disconnect electrical connectors to the tactical relay assembly.

(2) Remove screws (1, figure 5- 11) and lock-washers (2) to remove relay assembly from generator set.

NOTE

Tag and disconnect electrical leads to each component prior to removal.

b. Disassembly. Disassemble tactical relay assembly (items 3 through 26, figure 5-11), only as required for replacement of damaged parts.

c. Cleaning, Inspection, and Repair.

(1) Clean tactical relay assembly with filtered compressed air and a soft bristle brush. If necessary, dirt deposits may be removed with a clean, lint-free cloth moistened with an approved solvent. Dry thoroughly after cleaning with solvent.

(2) Inspect cover and chassis for cracks, corrosion, warping, dents, and defective paint.

(3) Inspect relays for cracked casing, corroded terminals and evidence of shorting or overheating.

(4) Inspect overload protective device for cracked casing, corroded terminals, and evidence of shorting or overheating.

(5) Inspect tactical relay resistor assembly for burns, cracked or damaged components, and evidence of shorting.

(6) Inspect terminal board assembly for cracks, corroded terminals and terminal jumpers, and evidence of shorting.

(7) Inspect wiring harness assembly for excessive wear, cracks, stripped threads, damaged or loose pins in connectors, and burned wires indicating shorts. Check individual wires for continuity using figure 5-12 as a guide.

(8) Check all threads for crossing, stripping, and peening.

(9) Test reverse power relay as follows:

(a) Install reverse power relay in test circuit shown in figure 5-13.

(b) Place all switches in the open position and activate power source G 1. Adjust output until voltmeter V1 indicates 3 volts.

(c) Place switch S2 in position B and activate power source G3.

(d) Place switches S1, S4, and S5 in the closed position.

(e) Test lamp DS2 shall illuminate.

(f) Activate power source G2 and adjust output until voltmeter V2 indicates 5 volts.

(g) Adjust output of power source G1 until voltmeter V1 indicates less than 1 volt.

(h) Position switch S2 in A position and switch S3 in closed position.

(i) Slowly increase output of power source G1 until test lamp DS2 extinguishes and test lamp DS1 illuminates.

(j) Check indication of voltmeter V1. Indication shall be 1 to 3 volts.

(10) Test over voltage relay as follows:

(a) Install relay in test circuit shown on figure 5-14.

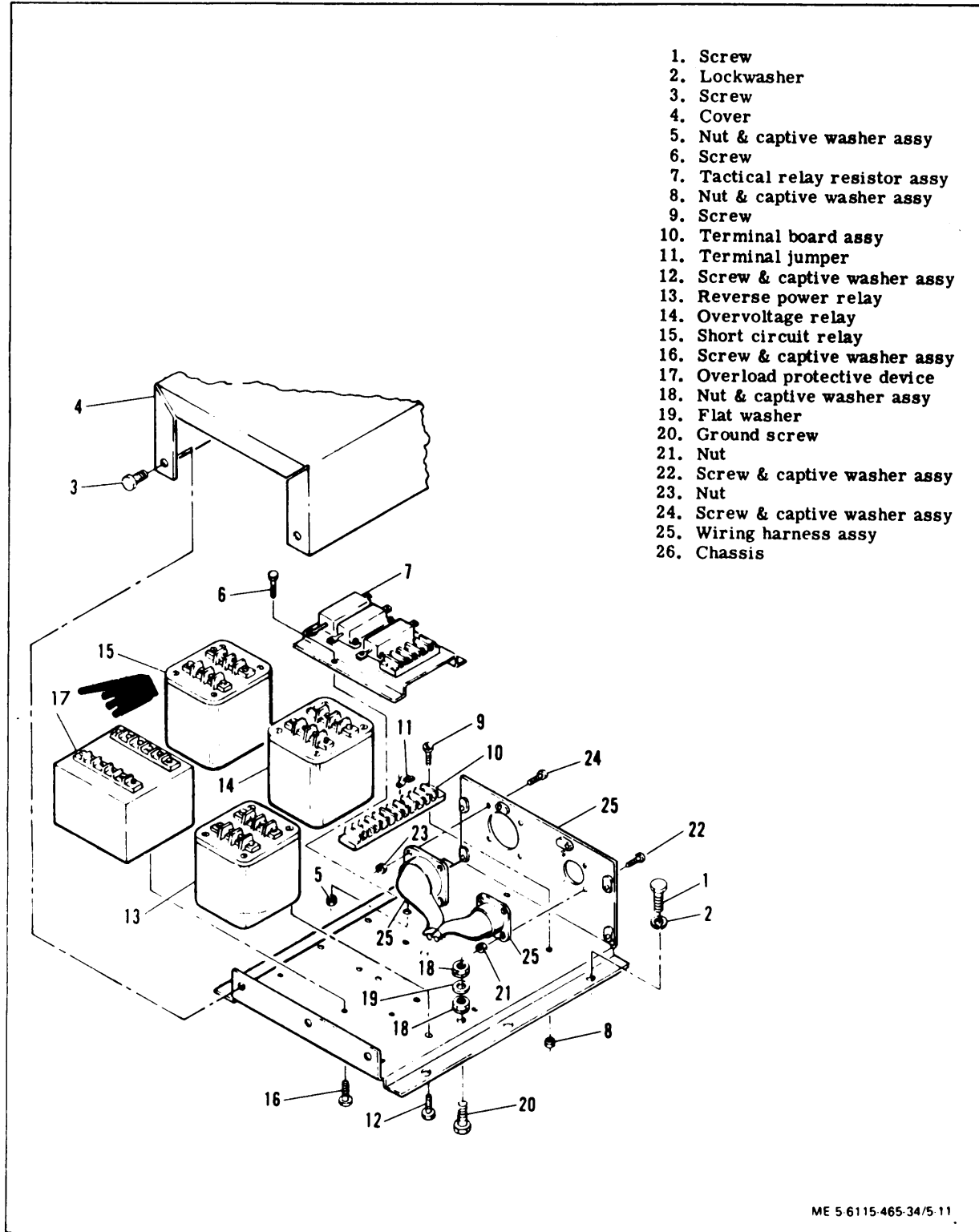

ME 5 6115-465-34/5-11

Figure 5-11. Tactical Relay Assembly, Exploded View

WIRE RUNNING LIST

WIRE MARKING	TERMINATION				WIRE FIND NO	WIRE LENGTH REF	MARKING COLOR
	FROM	FIND NO REF	TO	FIND NO REF			
D24E1B	J4-G	2	TB107-4	4	1	5.25	BLACK
D24F1B	K13-4	4	TB107-4	4	1	11.50	BLACK
D24H1B	J51-d	3	TB107-4	4	1	8.25	BLACK
F101E1B	J51-x	3	TB105-7	4	1	9.00	BLACK
F101G1B	K15-2	4	TB105-7	4	1	12.50	BLACK
F101H1B	J4-N	2	TB105-7	4	1	6.00	BLACK
F102F1B	J51-N	3	TB105-6	4	1	8.75	BLACK
F102G1B	K15-1	4	TB105-6	4	1	11.50	BLACK
F102H1B	J4-S	2	TB105-6	4	1	6.00	BLACK
P50V1B	J51-L	3	TB105-4	4	1	9.25	RED
P50W1B	K14-1(+)	4	TB105-4	4	1	14.75	RED
P50X1B	J51-B	3	K2-4	4	1	9.75	RED
P50GG1B	TB105-4	4	K15-3	4	1	12.50	RED
P55L1B	J51-M	3	TB105-5	4	1	9.50	RED
P55AX1B	J51-w	3	E3(GND)	5	1	13.00	RED
P55J1B	K15-4	4	TB105-5	4	1	13.50	RED
P55KL1B	K14-2(-)	4	TB105-5	4	1	14.75	RED
P58B1B	J51-A	3	K2-3	4	1	9.50	RED
P60B1B	J51-E	3	K15-7	4	1	12.00	RED
P61A1B	K15-3	4	K14-5(NC)	4	1	8.00	RED
P62H1B	J51-H	3	K14-6(NC)	4	1	10.50	RED
P62J1B	J51-b	3	K13-6	4	1	5.75	RED
P63A1B	J51-a	3	K13-5	4	1	6.25	RED
P200S1B	J51-P	3	TB105-8	4	1	8.75	RED
P200T1B	K14-3(NO)	4	TB105-9	4	1	14.50	RED
P200V1B	K2-3	4	TB105-8	4	1	11.25	RED
P200X1B	K15-5	4	TB105-6	4	1	7.50	RED
P200Y1B	K13-F	4	TB105-9	4	1	9.00	RED
P203D1B	J51-F	3	K13-7	4	1	5.25	RED
P205U1B	J51-D	3	K15-6	4	1	11.25	RED
P206D1B	J51-C	3	K2-7	4	1	6.50	RED
P209D1B	J51-G	3	K14-4(NO)	4	1	11.00	RED
X70U1B	J1-S	3	J4-A	2	1	7.25	BLACK
X8BV1B	J51-R	3	J4-B	2	1	7.00	BLACK
X9T1B	J4-C	2	TB105-1	4	1	8.25	BLACK
X9U1B	J51-J	3	TB105-1	4	1	11.00	BLACK
X9V1B	K2-1	4	TB105-1	4	1	7.25	BLACK
X12F1B	K2-2	4	TB105-2	4	1	6.50	BLACK
X12P1B	J51-K	3	TB105-2	4	1	10.25	BLACK
X12V1B	J4-K	2	TB105-3	4	1	7.00	BLACK
X12X1B	J4-L	2	TB105-2	4	1	7.50	BLACK
X12DD1B	J4-L	2	TB105-3	4	1	6.75	BLACK
X17B1B	J51-T	3	K14-A1	4	1	11.50	BLACK
X18B1B	J51-U	3	K14-B1	4	1	12.00	BLACK
X19B1B	J51-V	3	K14-C1	4	1	12.25	BLACK
X115A1B	J4-D	2	TB107-1	4	1	5.25	BLACK
X115B1B	K14-A2	4	TB107-1	4	1	14.25	BLACK
X115C1B	K13-1	4	TB107-1	4	1	13.00	BLACK
X116A1B	J4-E	2	TB107-2	4	1	5.00	BLACK
X116B1B	K14-B2	4	TB107-2	4	1	14.50	BLACK
X116C1B	K13-2	4	TB107-2	4	1	12.75	BLACK
X117A1B	J4-F	2	TB107-3	4	1	4.75	BLACK
X117B1B	K14-C2	4	TB107-3	4	1	15.25	BLACK
X117C1B	K13-2	4	TB107-3	4	1	12.00	BLACK

NOTES:

- ALL SOLDERED CONNECTIONS SHALL BE IN ACCORDANCE WITH MIL-STD-454, REQUIREMENT 5.
- CUT INSULATION SLEEVING, FIND NO. 8, INTO 32 PIECES .750 INCHES LONG AND INSTALL OVER WIRES AND PINS, AFTER SOLDERING, TO THE CONNECTORS, FIND NOS. 2 AND 3. THEN APPLY HEAT OF 400°F FOR 2-3 SEC. FOR PROPER SHRINKAGE.
- INSTALL STRAPS, FIND NO. 7, AT 3.0 MAX INTERVALS AND AT EACH CABLE BREAK-OUT.
- WIRE MARKING TO BE IN ACCORDANCE WITH MIL-W-5088 EXCEPT THAT LENGTH BETWEEN GROUPS OF NUMBERS SHALL NOT EXCEED 6 INCHES.
- CRIMPED TERMINAL SHALL MEET THE PERFORMANCE REQUIREMENTS OF MIL-T-7928.
- INTERPRET DRAWING PER MIL-STD-100.
- REFERENCES:
  - FOR WIRING DIAGRAM, SEE DRAWING 72-2205.
  - FOR SCHEMATIC DIAGRAMS, SEE DRAWINGS 72-2200 AND 72-2269.

72-2295 AND 72-2277 FOR UTILITY.  
 72-2200 AND 72-2269 FOR PRECISE.

8				M23053/5-105-0	24	INSULATION SLEEVING	MIL-I-23053/5	
7				MS33C7-5-9	AR	STRAP, CABLE, ADJUSTABLE		
6						(NOT USED)		
5				MS25036-149	1	LUG, TERMINAL, NO. 8 STUD, 18 AWG		
4				MS25036-102	71	LUG, TERMINAL, NO. 6 STUD, 18 AWG		
3				MS3102R28-12P	1	CONNECTOR, RECEPTACLE, ELECTRICAL J51		
2				MS3102R20-29P	1	CONNECTOR, RECEPTACLE, ELECTRICAL J4	MIL-W-5086/2	
1				MS086/2-18-9	AR	WIRE ELECTRICAL AWG 18		
FIND NO	SYM	CODE IDENT	DWG SIZE	PART OR IDENTIFYING NO	QTY REQD	NOMENCLATURE OR DESCRIPTION	SPECIFICATION	MATERIAL

ME5-6115-465-34/5-12(1)

Figure 5-12. Tactical Relay Assembly Wiring Harness, Drawing No. 72-2243 (Sheet 1 of 2)





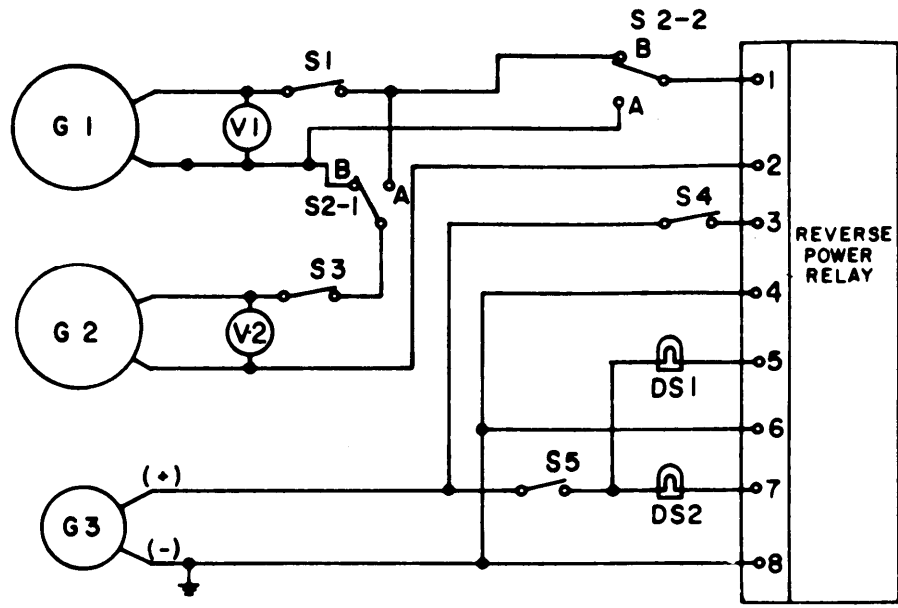

LEGEND:

- G1 POWER SOURCE, 0-5 VOLT DC, VARIABLE
- G2 POWER SOURCE, 0-10 VOLT AC, 60HZ, VARIABLE
- G3 POWER SOURCE, 24 VOLT DC
- DS1 TEST LAMP
- DS2 TEST LAMP
- S1 SWITCH
- S2 SWITCH
- S3 SWITCH
- S4 SWITCH
- S5 SWITCH
- V1 VOLTMETER
- V2 VOLTMETER

ME 5-6115-465-34/5-13

Figure 5-13. Reverse Power Relay Test Circuit

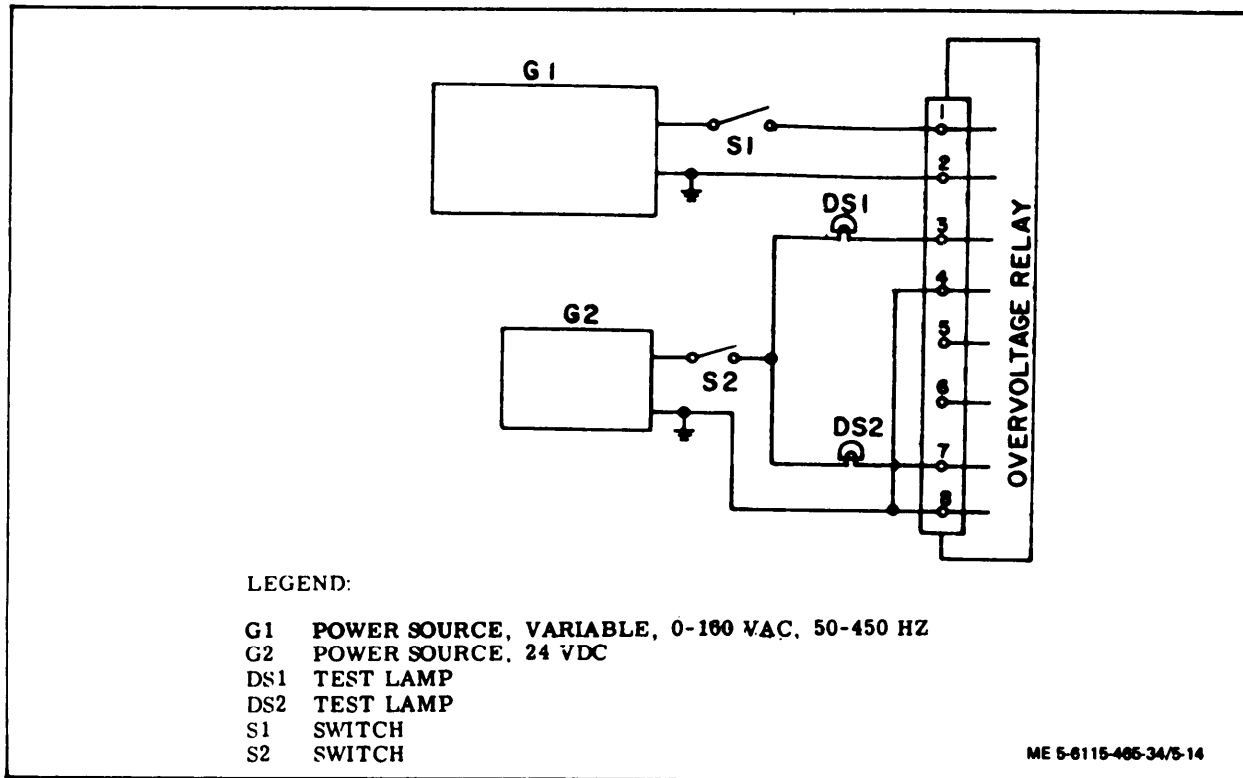

Figure 5-14. Overvoltage Relay Test Circuit

(b) Activate power source G 1 and adjust voltage to 120 Vac at 50 Hz.

(c) Activate power source G2 and close switch S2.

(d) Test lamp DS1 shall illuminate and test lamp DS2 shall remain extinguished.

(e) Vary frequency output of power source G1 from 50 to 450 Hz. There shall be no change in test lamp illumination.

(f) Slowly increase output voltage of power source G1 to 149 Vac. Vary frequency from 350 to 450 Hz. DS1 shall remain illuminated and DS2 shall extinguish.

(g) Slowly increase output voltage of power source G 1 to 154 Vat. Vary output frequency from 50 to 100 Hz. DS1 shall remain illuminated and DS2 shall remain extinguished.

(h) Set output frequency of power source G1 to 50 Hz. Slowly increase output voltage to 156 volts. DS1 shall extinguish and DS2 shall illuminate. Momentarily open switch S1 and allow relay to reset.

(i) Repeat step (h) for frequencies of 60, 70 and 100 Hz.

(j) Set output frequency of power source G1 to 350 Hz. Increase output voltage to 151 volts ac. DS1 shall extinguish and DS2 shall illuminate. Momentarily open switch S1 and allow relay to reset.

(k) Repeat step (j) *for* frequencies of 400 and 450 Hz.

(11) Test short circuit relay as follows:

(a) Install short circuit relay in test circuit shown in figure 5-15.

(b) Activate power sources G1 ad G2.

(c) Place switch S2 in the A position and close S1.

(d) Slowly increase output voltage of power source G1. Test lamp DS1 shall illuminate.

(e) Observe voltmeter V1 while continuing to increase voltage. **At** a voltage of  $24 \pm 1$  Vac, test lamp DS1 shall extinguish and DS2 shall illuminate.

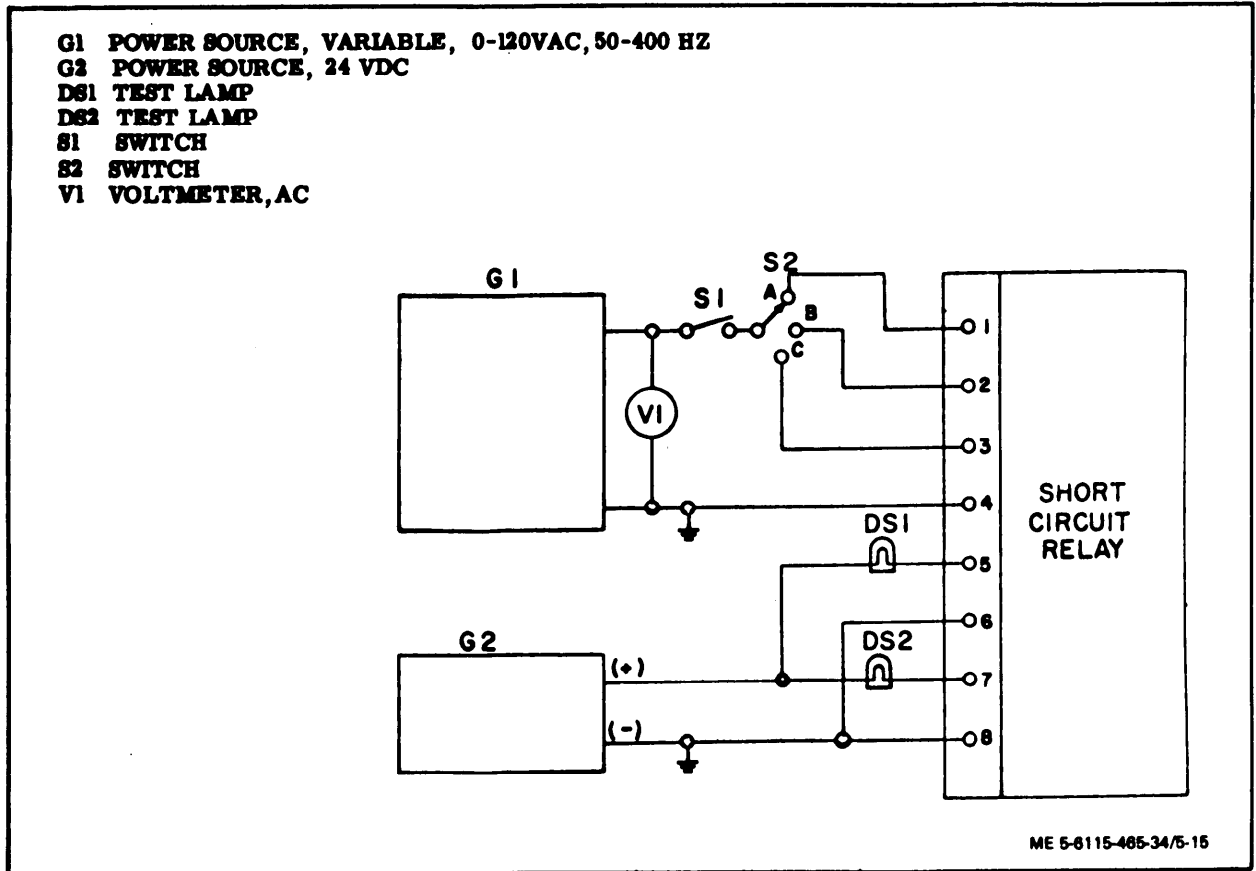

Figure 5-15. Short Circuit Relay Test Circuit

(f) Return output voltage of G1 below 24 Vac and open A allowing the relay to reset.

(g) Place switch S2 in B position and close switch S1.

(h) Repeat steps (d) through (f).

(i) Place switch S2 in C position and close switch S1.

(j) Repeat steps (d) through (f).

(k) The voltage at which relay trips in step(e), (h) and (j) shall be within 1 volt.

(12) Test overload protective device as follows:

(a) Install overload protective device in test circuit shown in figure 5-16.

(b) Activate generator G2 and power source G1 and close switch S1. Test lamp DS1 shall illuminate.

(c) Adjust auto transformers T1, T2, and T3 until ammeters A1, A2, and S3 indicate 0.75 amperes each.

(d) Adjust auto transformer T1 until ammeter A1 indicates 0.975 amperes. After  $8 \pm 2$  minutes, test lamp DS1 shall extinguish and test lamp DS2 shall illuminate.

(e) Adjust auto transformer T1 until ammeter A1 again indicates 0.75 amperes. Test lamp DS2 shall extinguish and test lamp DS1 shall illuminate.

(f) Repeat steps (d) and (e) for auto transformers T2, and T3. Result shall be the same as for T1.

(13) Replace any relay or protective device found to be defective.

(14) Test tactical relay resistor assembly as follows:

(a) Connect one lead of an ohmmeter to terminal number (4, figure 5-17).

**LEGEND:**

- A1 AMMETER
- A2 AMMETER
- A3 AMMETER
- DS1 TEST LAMP
- DS2 TEST LAMP
- G1 POWER SOURCE, 24 VDC
- G2 POWER SOURCE, 120/208 VAC, 60 HZ
- R1 RESISTOR, 35 OHM, 50 WATT
- R2 RESISTOR, 35 OHM, 50 WATT
- R3 RESISTOR, 35 OHM, 50 WATT
- S1 SWITCH
- T1 AUTOTRANSFORMER
- T2 AUTOTRANSFORMER
- T3 AUTOTRANSFORMER

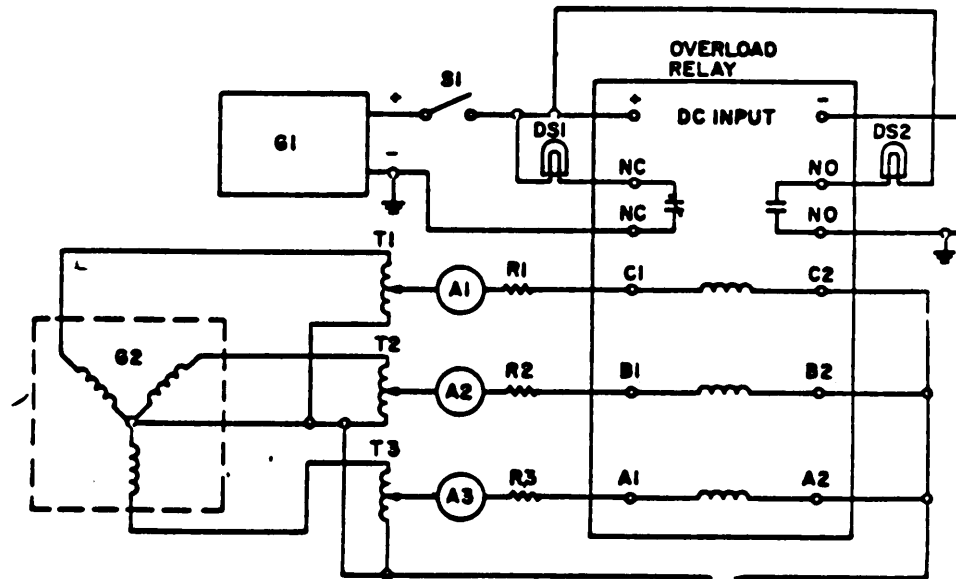

ME 5-6115-465-34/5-16

Figure 5-16. Overload Protective Device Test Circuit

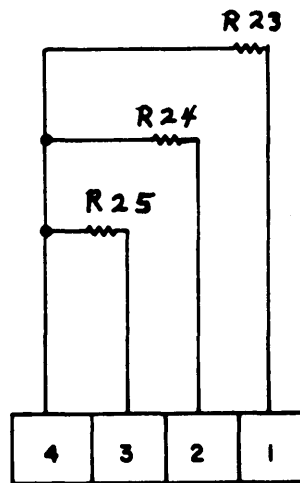

ME 5-6115-465-34/5-17

Figure 5-17. Tactical Relay Resistor Assembly Schematic Diagram

(b) Touch other lead to terminals 3, 2, and 1.

(c) Ohmmeter should indicate 7.5 ohms in each case.

(15) Replace defective components of tactical relay resistor assembly using figure 5-18 as a guide.

(16) If the wiring harness has sustained damage and requires repair or rebuild, refer to figure 5-12 for layout, identification and material requirements and Appendix A for detailed soldering and replacement procedures.

d. Installation. Install tactical relay assembly in reverse order of removal procedures.

#### 5-11. SPECIAL RELAY ASSEMBLY

#### **WARNING**

Do not attempt to perform maintenance on the special relay assembly while the generator set is operating. Severe electrical shock or death may result from failure to observe this warning.

a. Removal.

(1) Tag and disconnect electrical connectors to special relay assembly.

(2) Remove screws (1, figure 5-19) and lock-washers (2) to remove special relay assembly.

b. Disassembly. Disassemble special relay assembly (items 3 through 49, figure 5-19) only as required for inspection, testing, and replacement of components.

c. Cleaning, Inspection, and Repair.

(1) Clean special relay components with filtered compressed air and a soft bristle brush. If necessary, dirt deposits may be removed with a clean, lint-free cloth moistened in an approved solvent.

(2) inspect potentiometer for cracked casing, corroded terminals and burns or other indication or shorting.

(3) Inspect wiring harness assembly for cracked or deteriorated insulation, damaged or loose connector pins, and burned areas indicating shorting.

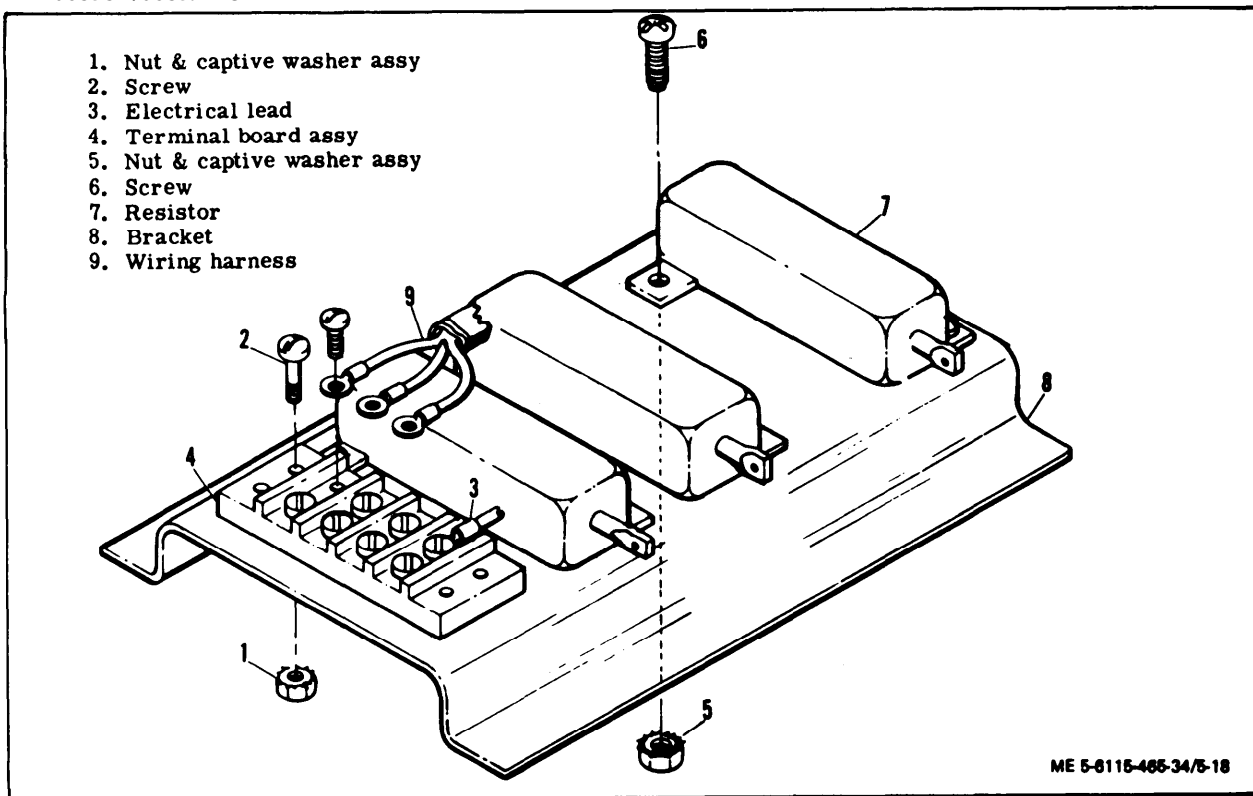

Figure 5-18. Tactical Relay Resistor Assembly, Exploded View

(4) Inspect protective caps for cracks, excessive wear, broken chain and other damage.

(5) Inspect components of DC relay assembly for cracks, burns, corrosion, and evidence of shorting or overheating.

(6) Inspect instrument shunt for turns, corrosion, and evidence of shorting.

(7) Inspect special current transformer for corroded terminals and burns or other evidence of shorting.

(8) Inspect cranking relay K3 for cracked casing, corroded terminals, and evidence of shorting.

(9) Inspect terminal boards for cracks, burns, corroded terminals and terminal jumpers and other damage.

(10) Inspect resistor for burns, corroded terminals and other damage.

(11) Inspect chassis and cover for cracks, warping, and illegible markings.

(12) Check all threads for crossing, stripping, and peening.

(13) Using an ohmmeter, test potentiometer as follows:

(a) Connect ohmmeter leads between center terminal and either outer terminal.

(b) Slowly, at an even rate, rotate adjustment from full counter clockwise to full clockwise position.

(c) Ohmmeter indication shall change at an even rate from 0 to 12 ohms.

(d) Replace potentiometer if ohmmeter indicates discontinuity at any point or if rate of change is erratic.

(14) Test wiring harness assembly wires for continuity using figure 5-20 as a guide.

(15) If wiring, wiring harness has sustained damage and requires repair or rebuild, refer to figure 5-20 for layout, identification and material requirements and Appendix A for detailed soldering and replacement procedures.

(16) Test dc relay assembly as follows:

(a) Apply 24 Vdc to terminals 6 and 15 (figure 5-21).

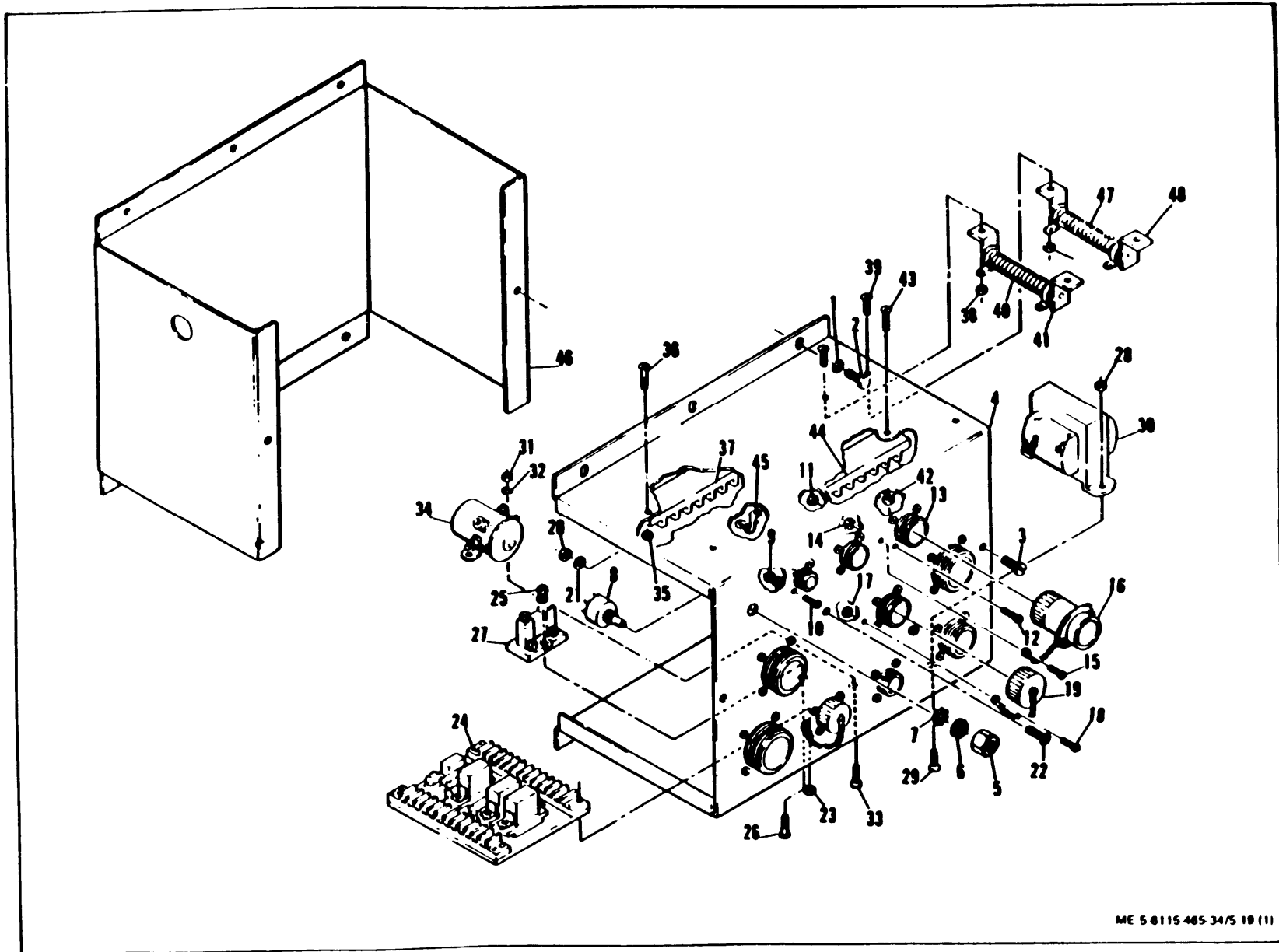

ME 5 6115 465 34/5 18 (1)

Figure 5-19. Special Relay Assembly, Exploded View (Sheet 1 of 2)

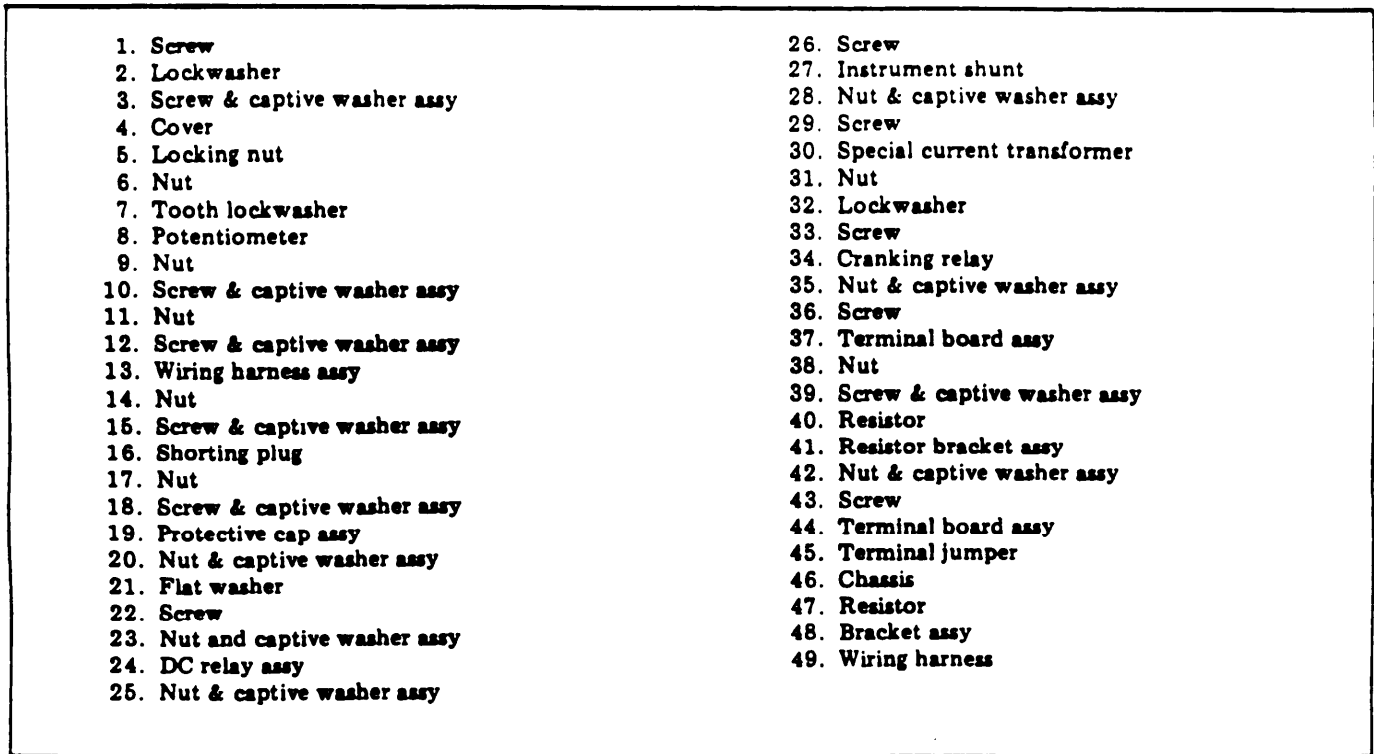

Figure 5-19. Special Relay Assembly, Exploded View (Sheet 2 of 2)

(b) Use an ohmmeter to check for continuity across terminals 5 and 17.

(c) Check for open circuit across terminals 4 and 16.

(d) Install a jumper between terminals 9 and 6.

(e) Apply 24 Vdc to terminals 12 and 15 with 12 positive.

(f) Check for continuity between terminals 5 and 17 and for open circuit between terminals 4 and 16.

(g) Install a jumper between terminals 23 and 6.

(h) Apply 24 Vdc to terminals 21 and 15 with 21 positive.

(i) Check for continuity between terminals 5 and 17 and for open circuit terminals 4 and 16.

(j) Apply 24 Vdc to terminals 13 and 15.

(k) Check for continuity between terminals 1 and 14 and between terminals 2 and 15. Check for open circuit between terminals 3 and 15.

(l) Apply 120 Vdc to terminals 18 and 22 with 22 positive. Use an ohmmeter check for resistance of 2500 ohms between terminals 19 and 20 and 7 and 8.

(m) Check resistors R3, R6, and R9 for correct values given in figure 5-21.

(17) Replace defective dc relay assembly component (items 1 through 21, figure 5-22).

(18) If any dc relay assembly component must be replaced or encapsulating coating repaired or replaced, refer to Appendix A references for detailed procedures. Repair/replace encapsulating by applying a 0.007 inch (rein) coating of polyurethane resin (Scotchcast 221, Minnesota Mining and Mfg. Co. or equal).

(19) Replace any damaged or defective parts.

d. Installation. Install special relay assembly in reverse order of removal procedures.

## 5-12. PRECISE RELAY ASSEMBLY

e. Manufacture. To manufacture the plug, chain assembly use the connector, plug, electrical NSN 5935-00-548-1529, CAGE/PN (96906) MS3456W24-28P. Also use the wire, electrical NSN 6145-00-578-6605, CAGE/PN (81349) M5086/2-16-9. Connect pin (H) to pin (L) per figure 5-19.1.

### CAUTION

Do not attempt to perform maintenance on the precise relay assembly while the generator is operating. Severe electrical shock may result from failure to observe this warning.



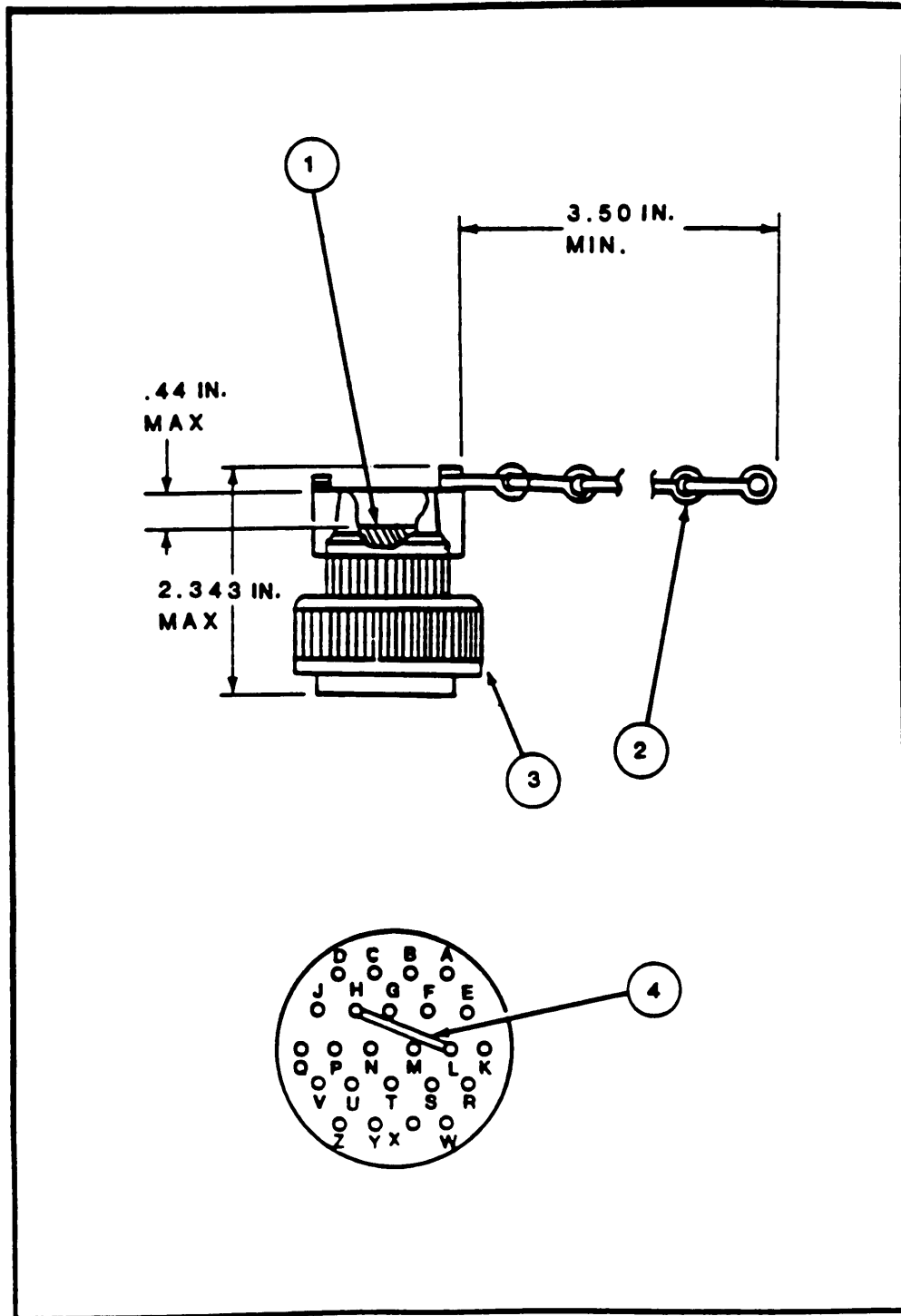

Figure 5-19.1. Connector plug, Electrical



WIRE RUNNING LIST							
MARKING	TERMINATION				WIRE FIND NO REF	WIRE LENGTH REF	MARKING COLOR
	FROM	FIND NO REF	TO	FIND NO REF			
P210B18	J31-V	9	J6-N	2	24	15.50	RED
P40018	J29-A	8	T8101-1	12	24	22.50	RED
P45M18	J29-D	8	T8101-11	12	24	17.75	RED
P47H18	J29-F	8	T8101-9	12	24	19.00	RED
J44G18	J29-G	8	T8101-10	12	24	17.75	RED
P56E18	J29-H	8	T8101-13	12	24	17.75	RED
P55P18	J29-E	8	E4-B	13	24	5.25	RED
P55D12	J7-A	3	E4-B	16	23	7.50	RED
P51A18	J7-B	3	T8102-1R	12	24	31.50	RED
V64B12	J7-C	3	T8101-19	17	23	25.00	RED
V65B12	J7-D	3	T8101-18	17	23	25.00	RED
P141B12	J7-E	3	R13-2	21	23	5.00	RED
P45J18	J6-A	2	T8101-11	12	24	24.50	RED
P200B18	J6-C	2	T8102-20	12	24	21.00	RED
P208B18	J6-L	2	A5-17	12	24	17.25	RED
P66A18	J6-B	2	A5-3	12	24	18.50	RED
X96A18	T8101-17	12	T101-2	12	24	22.25	BLACK
P47E18	T8101-9	12	A5-16	12	24	19.50	RED
P50L18	T8101-5	12	A5-21	12	24	22.50	RED
P40F18	T8101-2	12	A5-1	12	24	28.50	RED
P200J18	T8102-19	12	A5-5	12	24	20.75	RED
P51E18	T8102-18	12	A5-24	12	24	18.00	RED
X194018	T8102-18	12	R29-2	NOTE B	24	11.50	BLACK
X90018	T8102-15	12	R31-2	NOTE B	24	10.00	BLACK
X90E18	T8102-15	12	T101-3	12	24	18.00	BLACK
X197E18	T8102-14	12	R31-1	NOTE B	24	11.25	BLACK
X197F18	T8102-14	12	T101-4	12	24	19.00	BLACK
X195F18	T8102-13	12	R29-1	NOTE B	24	10.75	BLACK
X195E18	T8102-13	12	T101-1	12	24	19.00	BLACK
X9718C	T8102-1	12	A5-22	12	24	26.50	BLACK
P55C18	A5-15	12	E4-B	13	24	19.50	RED
P49A18	A5-9	12	K3-X1	12	24	21.25	RED
P55F18	K3-X2	12	E4-A	13	24	15.25	RED
P14CD12	X3-A1	15	R13-1	21	23	5.50	RED
P55T12	E4-A	16	E4-B	16	23	30.00	RED
D13A18	R35-1	NOTE B	A5-14	12	24	19.25	RED

25		MS086/2-16	AR	WIRE, ELECTRICAL, 16 AWG MIL-I-5086/2		
24		MS086/2-18	AR	WIRE, ELECT, 18 AWG MIL-W-5096/2		
23		MS086/1-12	AR	WIRE, ELECT, 12 AWG MIL-W-5086/2		
				NOT USED		
21		MS25036-157	4	TERMINAL LUG, NO. 250 STUD, 12 AWG		
20		MS3367-5-9	AR	STRAP, CABLE, ADJUSTABLE		
19				NOT USED		
18		M23053/5-105-0	141-3/4	INSULATION SLEEVING	MIL-I-23053/5	
17		MS17143-6	4	TERMINAL LUG, NO. 6 STUD, 12 AWG		
16		MS25036-15G	5	TERMINAL LUG, NO. 8 STUD, 12 AWG		
15		MS25036-112	2	TERMINAL LUG, NO. 10 STUD, 12 AWG		
14		MS25036-106	4	TERMINAL LUG, NO. 6 STUD, 16 AWG		
13		MS150-36-149	15	TERMINAL LUG, NO. 8 STUD, 18 AWG		
12		MS25036-102	119	TERMINAL LUG, NO. 6 STUD, 18 AWG		
11		MS3102R36-7P	1	CONNECTOR, ELECT, J5		
10		MS3102R28-125	1	CONNECTOR, ELECT, J50		
9		MS3102R24-285	1	CONNECTOR, ELECT, J31		
8		MS3102R22-195	1	CONNECTOR, ELECT, J29		
7						
6		MS3102R20-295	1	CONNECTOR, ELECT, J15		
5		MS3102R32-7P	1	CONNECTOR, ELECT, J10		
4		MS3102R145-65	1	CONNECTOR, ELECT, J3		
3		MS3102R18-115	1	CONNECTOR, ELECT, J7		
2		MS3102R20-275	1	CONNECTOR, ELECT, J6		
1		MS3102R36-75	1	CONNECTOR, ELECT, J2		
FIND NO	SYM	CODE IDENT	PART OR IDENTIFYING NO.	QTY REQ	NOMENCLATURE OR DESCRIPTION	SPECIFICATION

LIST OF MATERIAL

NOTES:

- ALL SOLDERED CONNECTIONS SHALL BE IN ACCORDANCE WITH MIL-STD-454, REQUIREMENT 5.
- CUT INSULATION SLEEVING, FIND NO. 18, INTO 189 PIECES, .750 INCHES LONG AND INSTALL OVER WIRES AND PINS. AFTER SOLDERING TO THE CONNECTORS, FIND NOS. 1 THRU 11. THEN APPLY HEAT OF 400°F FOR 3-5 SEC. FOR PROPER SHRINKAGE
- INSTALL STRAPS, FIND NO. 10, AT 3.0 MAXIMUM INTERVALS AND AT EACH CABLE BREAK-OUT.
- WIRE MARKING SHALL BE IN ACCORDANCE WITH MIL-W-5088 EXCEPT THAT LENGTH BETWEEN GROUPS OF NUMBERS SHALL NOT EXCEED 6 INCHES.
- INTERPRET DRAWING PER MIL-STD-100.
- CRIMPED TERMINALS SHALL MEET THE PERFORMANCE REQUIREMENTS OF MIL-T-7928.
- REFERENCES:  
a) FOR WIRING DIAGRAM, SEE DRAWING 72-2205.  
b) FOR SCHEMATIC DIAGRAM, SEE DRAWING 72-2200.
- WIRES WITHOUT TERMINATION SHALL BE STRIPPED .375 AND TINNED IN ACCORDANCE WITH MIL-STD-454, REQUIREMENT 5.

ME5-6115-465-34/5-20(1)

Figure 5-20. Special Relay Assembly Wiring Harness, Drawing No. 72-2239 (Sheet 1a of 3)



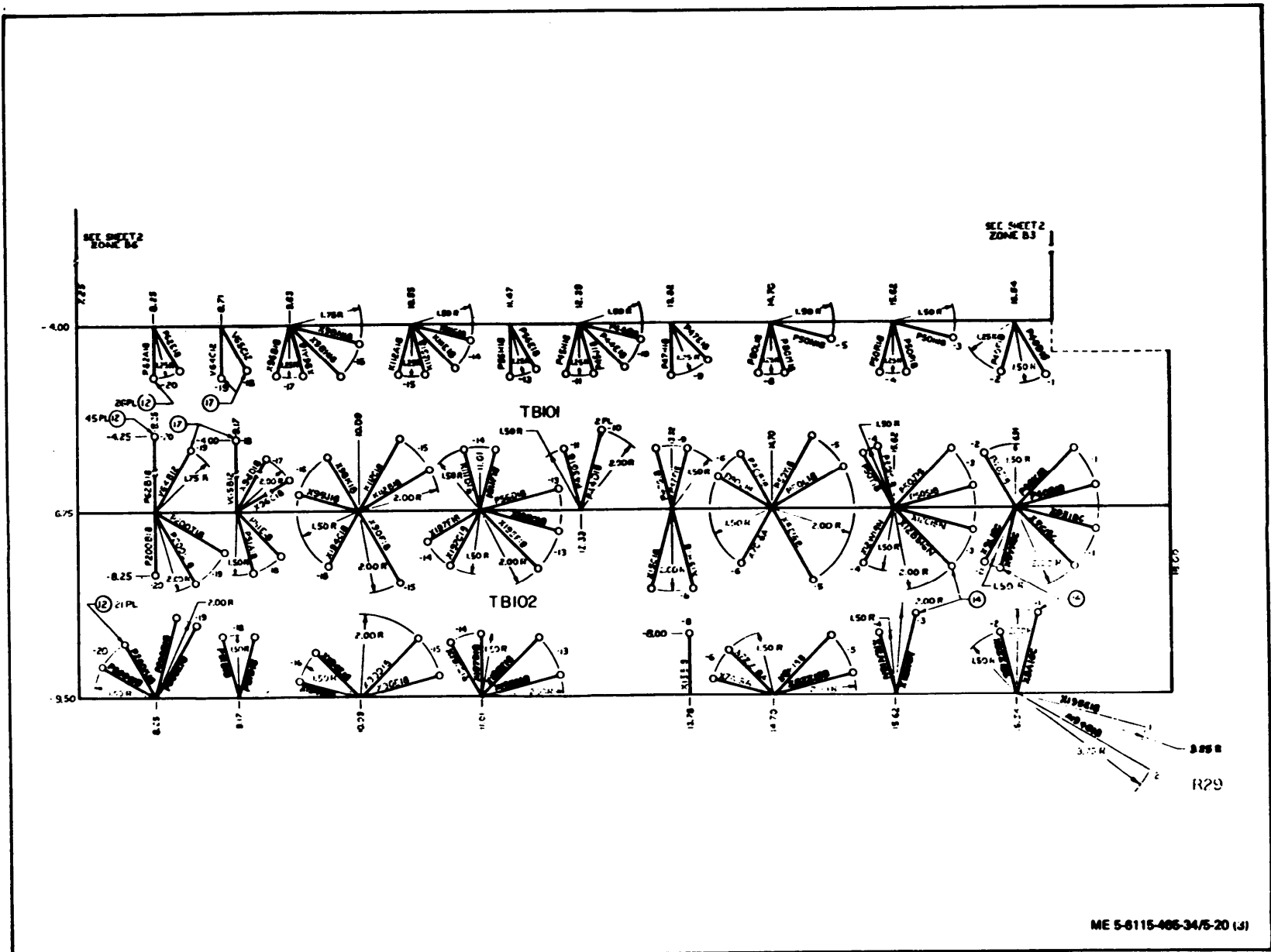

ME 5-6115-465-34/5-20 (J)

Figure 5-20. Special Relay Assembly Wiring Harness, Drawing No 72-2239 (Sheet 3 of 3!)

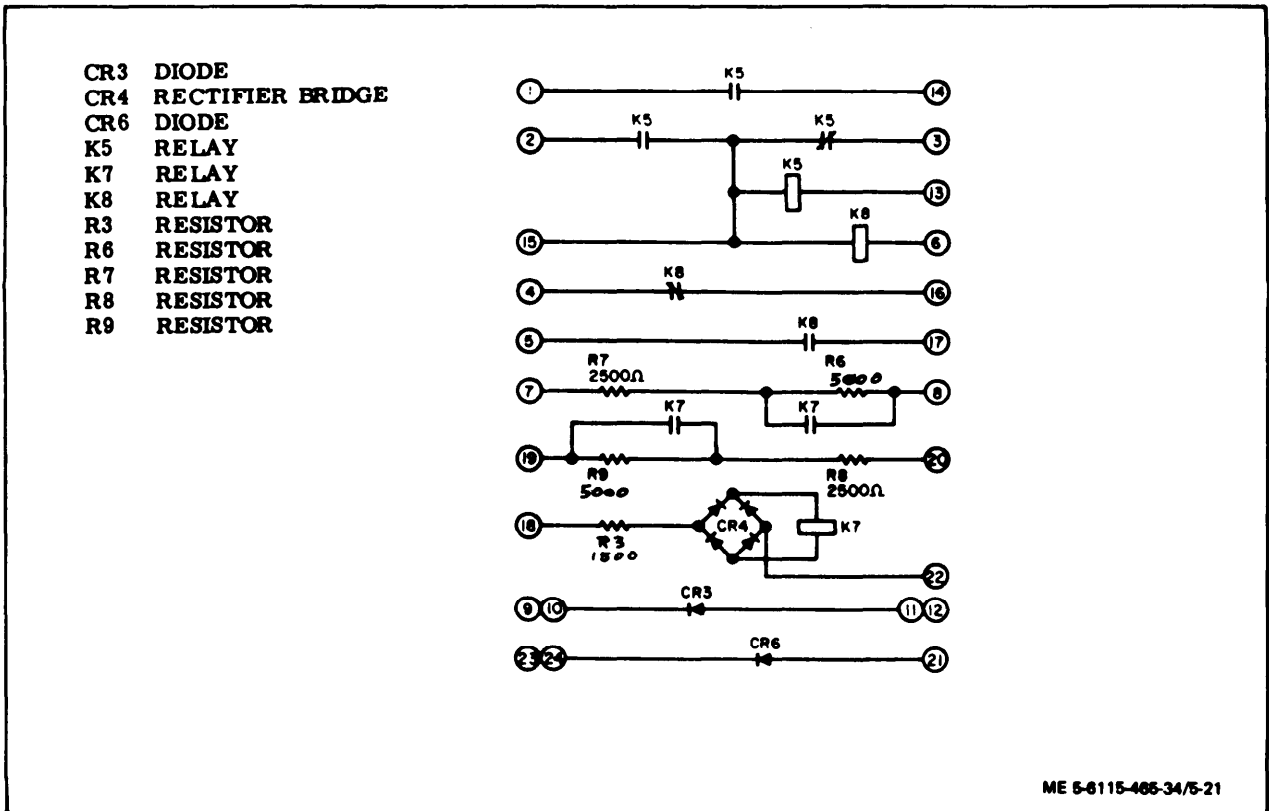

ME 5-6115-465-34/5-21

Figure 5-21. DC Relay Assembly Schematic Diagram

a. Removal.

- (1) Disconnect electrical connectors to precise relay assembly.
- (2) Remove screws (1, figure 5-23) and lock-washers (2) to remove precise relay assembly from generator set.

b. Disassembly. Disassemble precise relay assembly (items 3 through 33, figure 5-23) only as required to clean, inspect, test, or replace parts.

NOTE

Switch and attaching hardware (items 21 through 24) are found only on the 50/60 Hz precise relay assembly.

c. Cleaning, Inspection, and Repair.

- (1) Clean precise relay assembly with filtered compressed air and a soft bristle brush. If necessary, caked deposits may be removed with a clean, lint-free cloth moistened with an approved solvent. Dry thoroughly after cleaning with solvent.

- (2) Visually inspect cover and chassis for cracks, corrosion, warping, defective paint and illegible markings.

- (3) Inspect wiring harness for damaged wires and connectors for bent or broken connector pins and burned areas indicating shorts.

- (4) Inspect switch (50/60 Hz only) for cracked casing, burro, corroded terminals and other damage.

- (5) Inspect relays for cracked casing, corroded terminals, and evidence of shorting or other damage.

- (6) Inspect resistors and capacitors of electronic components assembly for insecure mounting and burns or other evidence of shorting.

- (7) Inspect terminal board assembly for cracks, corroded terminals, damaged terminal jumpers and evidence of shorting.

- (8) Test under voltage relay as follows:

- (a) Install relay in test circuit shown in figure 5-24.

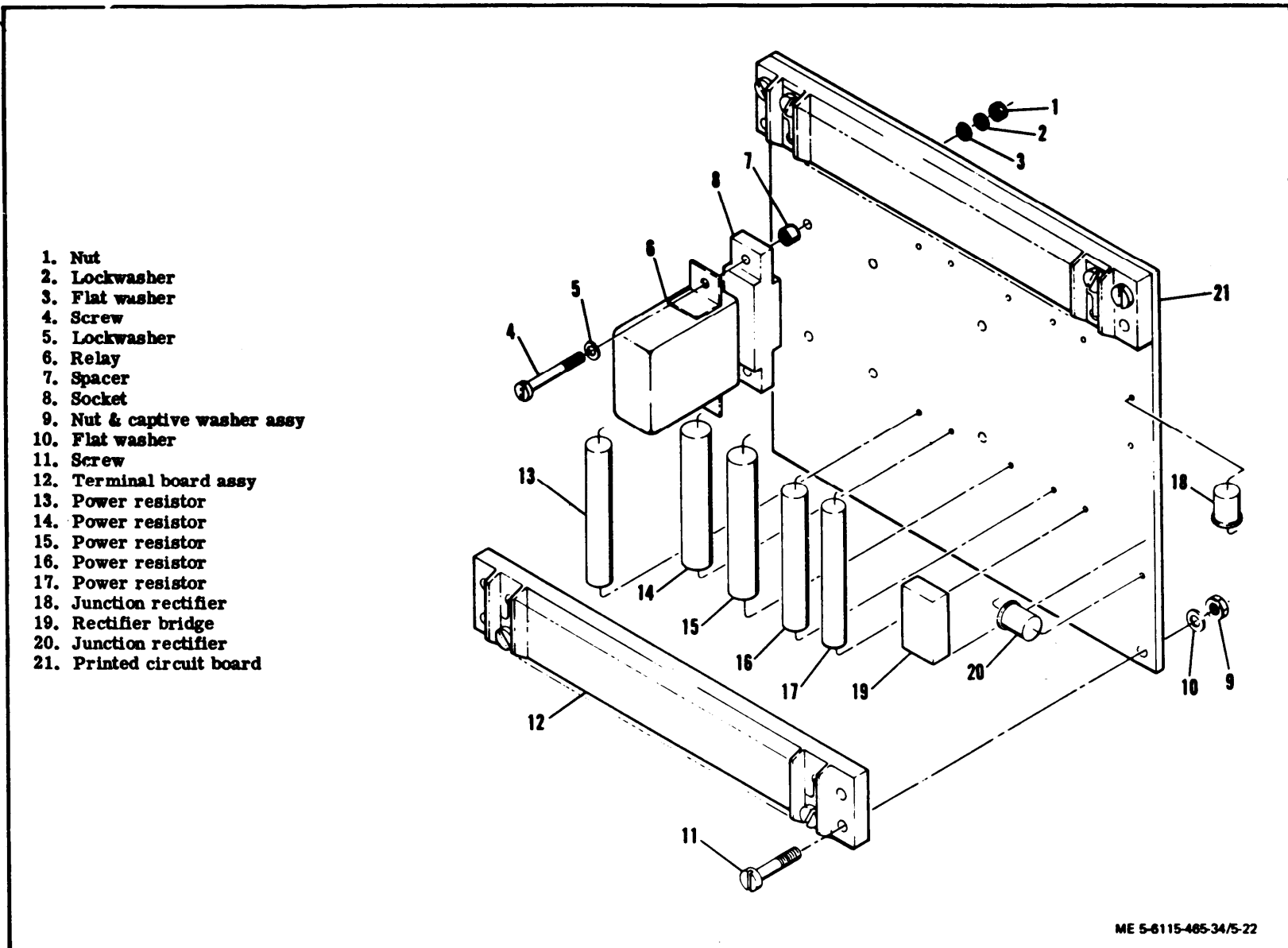

Figure 5-22. DC Relay Assembly, Exploded View

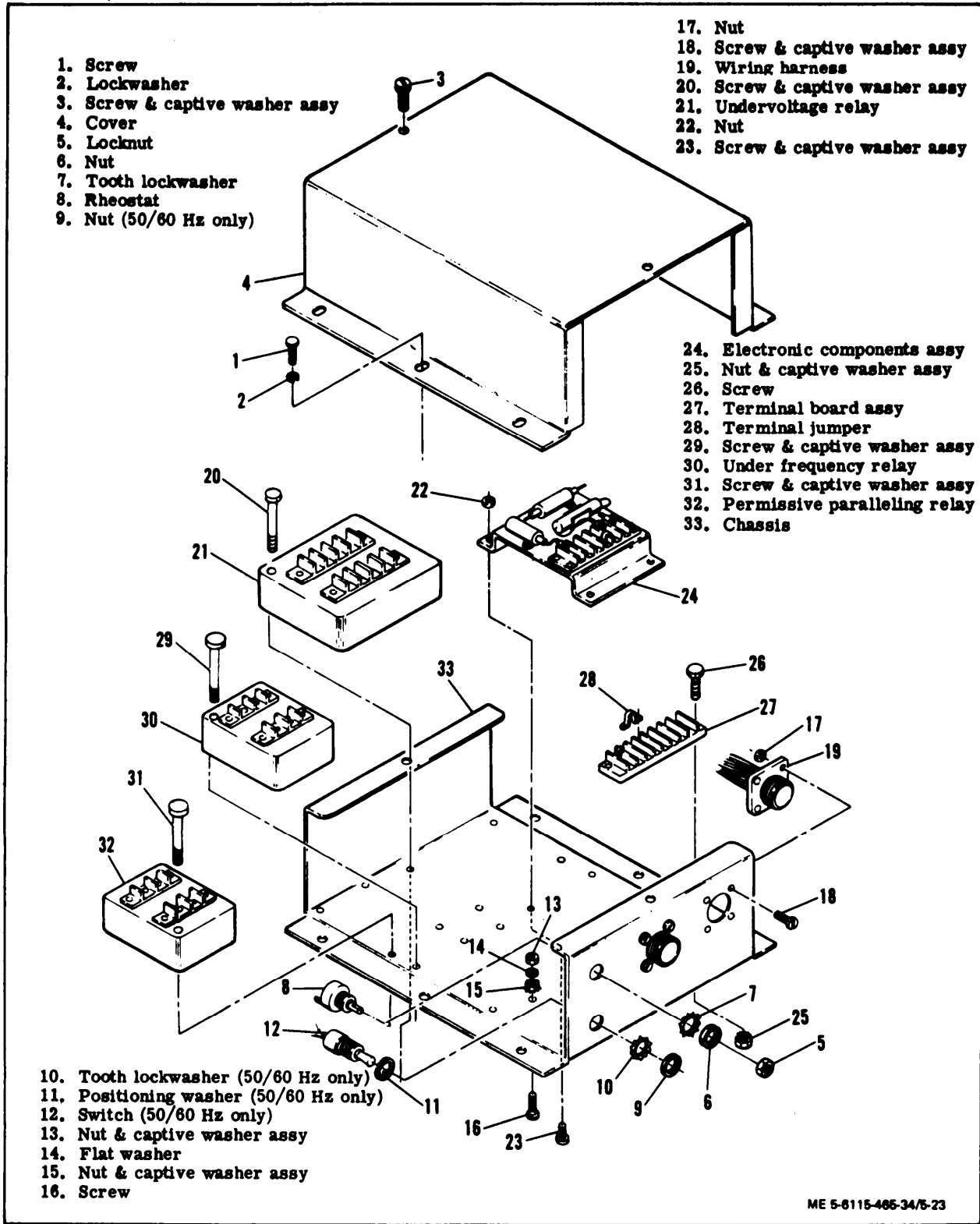

Figure 5-23. Precise Relay Assembly, Exploded View



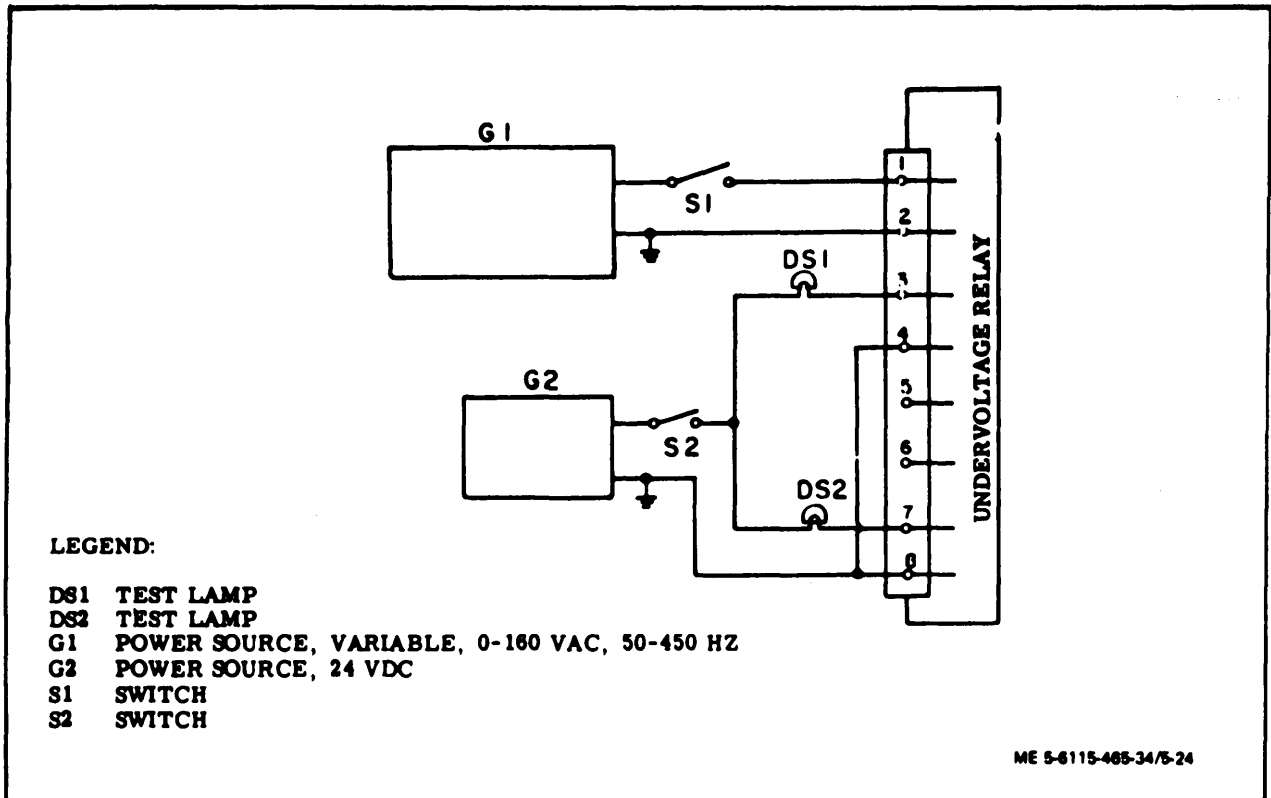

Figure 5-24. Under Voltage Relay Test Circuit

(b) Activate power source G1 and adjust output voltage to 120 Vac at 50 Hz.

(c) Activate power source G2.

(d) Close switches S1 and S2.

(e) Test lamp DS1 shall illuminate, and test lamp DS2 shall remain extinguished.

(f) Vary output frequency of power source G1 from 50 to 450 Hz. There shall be no change in test lamp illumination.

(g) Slowly decrease output voltage of power source G1 to 100 Vac. Vary output frequency from 350 to 450 Hz. Test lamp DS1 shall remain illuminated and test lamp DS2 shall remain extinguished.

(h) Slowly decrease output voltage of power source G1 to 95 Vac. Vary frequency from 50 to 100 Hz. DS1 shall remain illuminated and DS2 shall remain extinguished.

(i) Set output frequency of power source G1 to 50 Hz. Slowly decrease output voltage of power source G1 to 90 Vac. Test lamp DS1 shall extinguish

and test lamp DS2 shall illuminate. Set output frequency above 95 Vac and momentarily open switches S1 and allow relay to reset.

(j) Repeat steps (i) for frequencies of 60, 70, and 100 Hz.

(k) Set output frequency of power source G1 to 350 Hz. Slowly decrease output voltage to 90 Vac. DS1 shall extinguish and DS2 shall illuminate. Return output voltage to 120 Vac and momentarily open switch S1, allowing relay to reset.

(l) Repeat step (k) for output frequency of 400 and 450 Hz.

(9) Test under frequency relay as follow:

(a) Install relay in test circuit shown in figure 5-25.

(b) Activate power source G1 and G2 and adjust output frequency to 50 Hz (400 Hz for 400 Hz units).

(c) Close switch S1. Test lamp DS1 shall illuminate and DS2 shall remain extinguished.

LEGEND:

- DS1 TEST LAMP
- DS2 TEST LAMP
- F1 FREQUENCY METER, 0-400 HZ
- G1 POWER SOURCE, 120 VAC, 0-400 HZ
- G2 POWER SOURCE, 24 VDC
- S1 SWITCH

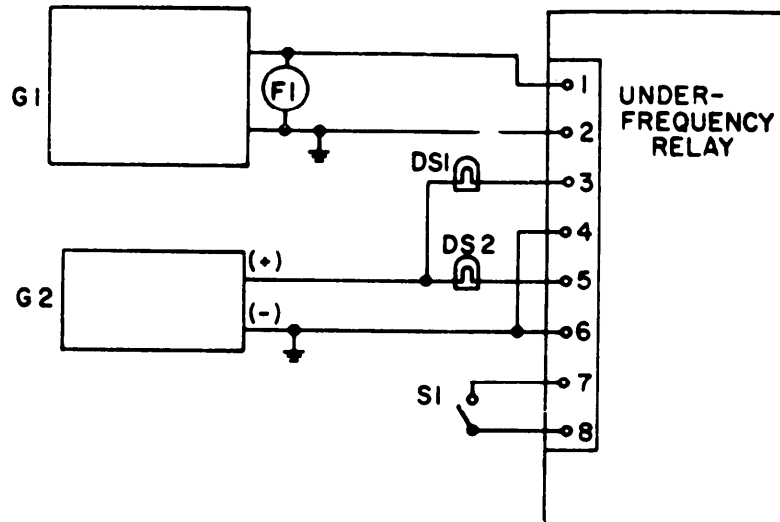

ME 5-6115-465-34/5-25

Figure 5-25. Under Frequency Relay Test Circuit

(d) Lower output frequency of power source G1 until test lamps transfer. Test lamps shall transfer at  $46 \pm 1$  Hz (370 Hz for 400 Hz units).

(e) Slowly raise output frequency of power source G1 until test lamps transfer. Test lamps shall transfer at  $46 \pm 1$  Hz (375 Hz for 400 Hz units).

(f) Adjust output voltage of power source G1 to 132 Vac. Check for test lamp transfer points. Transfer points shall be within 1 Hz of those of steps (d) and (e).

(g) Adjust output voltage of power source G1 to 108 Vac. Check for test lamp transfer points. Transfer points shall be within 1 Hz of those of steps (d) and (e).

(h) Open switch S1 and repeat steps (d) through (g). Transfer points shall be  $55 \pm 1$  Hz and  $58 \pm 1$  Hz ( $380 \pm 1$  Hz and  $385 \pm 2$  for 400 Hz units).

(10) Test permissive paralleling relay as follows:

(a) Install permissive paralleling relay into test circuit shown in figure 5-26.

(b) Check that switch (S1) is open, then energize power sources G1 and G2.

(c) Adjust power source G1 to obtain a reading of 15 Vac on voltmeter (M1).

(d) Adjust power source G1 to obtain a reading of 50 Hz on frequency meter (M2).

(e) Close switch (S1) and observe test lamps (DS1) and (DS2). DS1 shall be dark and DS2 shall be illuminated.

(f) Slowly reduce the voltage of power source G1 until the relay drops out (DS1 extinguishes and DS2 illuminates). Drop out shall occur at  $8 \pm 1$  Vac.

(g) Slowly increase the voltage of power supply G1 until relay pickup occurs (DS1 illuminates and DS2 extinguishes). Pickup shall occur at a voltage not greater than 1 Vac greater than drop out.

(h) Open switch (S1) and adjust frequency of power source G1 to 60 Hz.

(i) Repeat steps (e) through (g) above. Relay drop out and pickup shall occur at the same voltages.

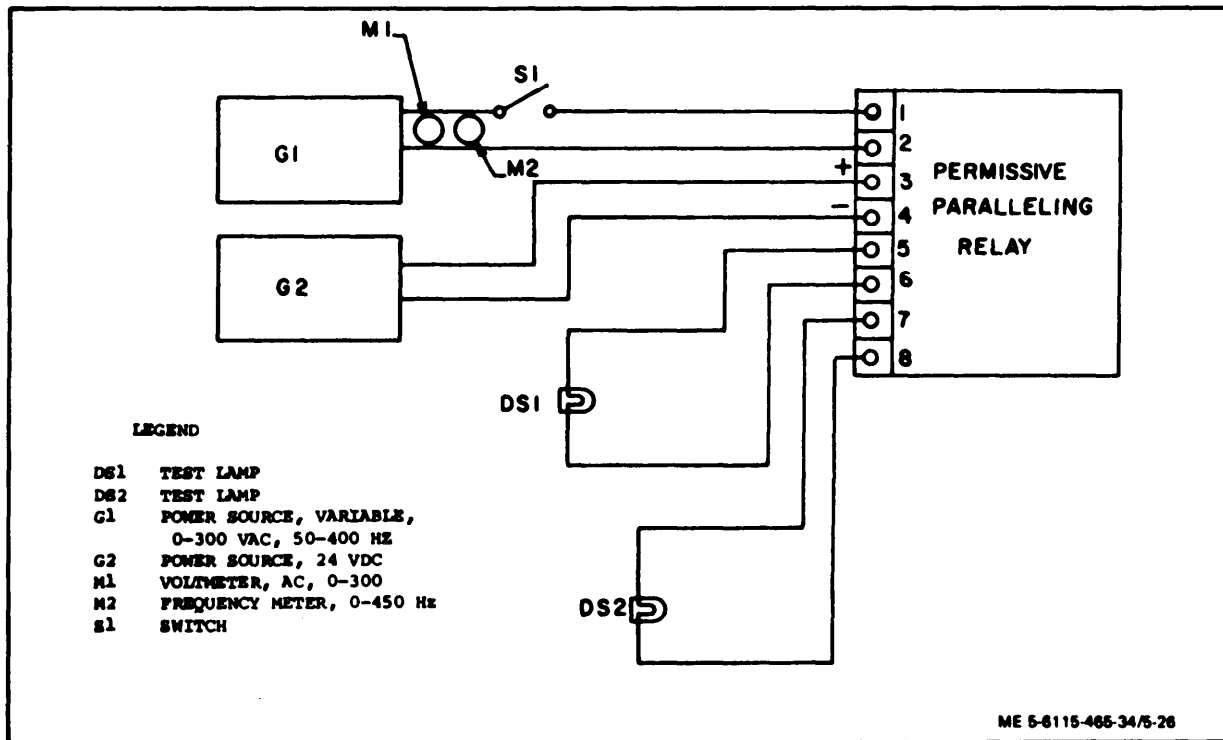

Figure 5-26. Permissive Paralleling Relay Test Circuit

(j) Open switch (S1) and adjust the frequency of power source G1 to 400 Hz.

(k) Repeat steps (e) through (g) above. Relay drop out and pick up shall occur at the same voltages.

(l) Increase the voltage of power source G1 to 300 Vac for 2 seconds. There shall be no damage as a result of this test.

(11) Replace relays which fail to perform as specified.

(12) Test electronic components assembly as follows: (See schematic diagram in figure 5-27.)

(a) Check resistance across terminals 1 and 2 and across terminals 3 and 4. Resistance should be as specified. If it is not, replace the defective resistors as necessary.

(b) Test capacitor (terminals 5 and 6). Replace, if defective.

(13) Replace defective components of electronic components assembly using figure 5-27 as a guide, and Appendix A references for detailed soldering and replacement procedures.

(14) If the wiring harness has sustained damage and requires repair or rebuild, refer to figure 5-28 (50/60 Hz) or 5-29 (400 Hz) for layout, identification and material requirements and Appendix A for detailed soldering and replacement procedures.

(15) Check individual wires for continuity. Replace defective wires using wire conforming to Military Specification MIL-W-5086, Type II. Use figures 5-28 or 5-29 as a guide.

d. Assembly. Assemble precise relay assembly in reverse order of removal procedures.

e. Installation. Install precise relay assembly in reverse order of removal procedures.

#### 5-13. STATIC EXCITER AND VOLTAGE REGULATOR ASSEMBLY.

a. General. The static exciter and voltage regulator assembly provide excitation and voltage regulation for the generator assembly. The voltage regulator senses generator output voltage and compares it to a reference voltage which is established by the voltage adjust rheostat on the generator set control cubicle. If difference exists, an error signal is sent to the static exciter. Excitation current supplied by the current transformer assembly is altered by the error signal until generator output voltage equals the reference voltage.

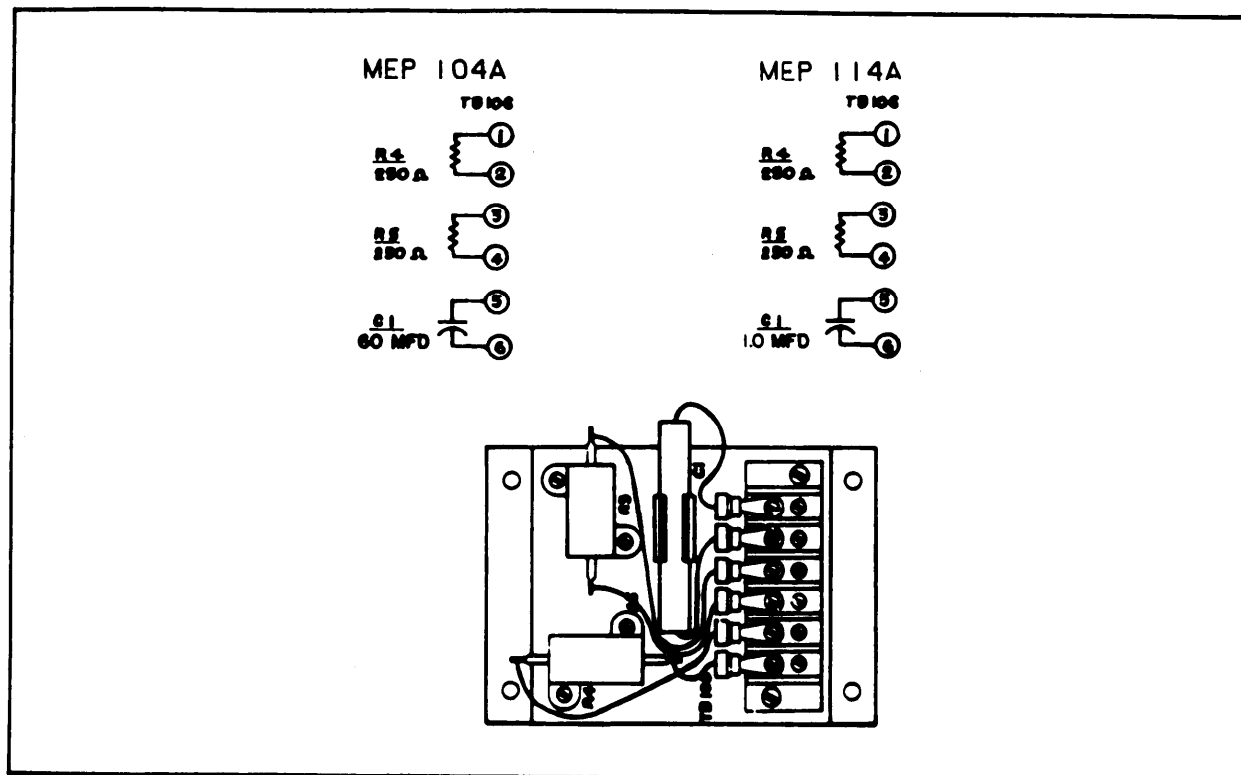

Figure 5-27. Electronics Components Assembly

NOTE

Do not attempt to perform maintenance on the static exciter and voltage regulator assembly while the generator set is operating. Severe electrical shock or death may result from failure to observe this warning.

h. Removal.

(1) Disconnect electrical connectors to static exciter and voltage regulator assembly.

(2) Remove screws (1, figure 5-30) and lock-washer (2) to remove static exciter and voltage regulator assembly from generator set.

c. Disassembly. Disassemble static exciter and voltage regulator assembly items 3 through 149, figure 5-30) only as required to clean, inspect, test and replace components.

Tag and disconnect electrical leads to each component before removing.

d. Cleaning, Inspection, and Repair.

(1) Clean static exciter and voltage regulator assembly with filtered compressed air and a soft brittle brush. If necessary, caked deposits may be removed with a clean, lint-free cloth moistened with an approved cleaning solvent. Dry thoroughly if cleaning solvent is used.

(2) Inspect cover and chassis for cracks, corrosion, warping, and other damage.

(3) Inspect heat sink assembly for cracks, corrosion, and signs of overheating or shorting.

(4) Using an ohmmeter, test semiconductors as follows:

(a) Using an ohmmeter, check, resistance through semiconductor in both directions.

WIRE MARKING	WIRE RUNNING LIST				WIRE FIND NO.	WIRE LENGTH REF	WIRE MARKING COLOR
	FROM	FIND NO. REF	TO	FIND NO. REF			
P81L18	J32-C	3	J8-C	2	1	8.50	RED
K110318	J32-G	3	J8-G	2	1	8.50	BLACK
K111818	J32-J	3	J8-J	2	1	8.50	BLACK
K102L18	J32-S	3	J8-S	2	1	9.00	BLACK
K101L18	J32-U	3	J8-U	2	1	9.00	BLACK
K32E18	J32-M	3	J8-M	2	1	9.00	BLACK
X9P18C	J32-A	3	TB104-1	4	1	8.00	BLACK
X12718N	J32-B	3	TB104-3	4	1	7.75	BLACK
P50AA18	J32-E	3	TB104-5	4	1	7.50	RED
P200N18	J32-K	3	TB104-7	4	1	6.75	RED
K35Y18	J32-D	3	TB104-6	4	1	7.75	RED
P55RR18	J32-Z	3	E2	6	1	11.00	RED
L93F18	J32-P	3	K16-1	4	1	12.00	BLACK
X15J18	J32-R	3	K16-2	4	1	12.50	BLACK
P57J18	J32-L	3	K16-8	4	1	12.50	RED
K33E18	J32-N	3	TB106-2	4	1	10.25	BLACK
K34E18	J32-T	3	TB106-4	4	1	9.50	BLACK
P60C18	J32-H	3	K11-7	4	1	12.50	RED
P204D18	J32-F	3	K11-3	4	1	11.50	RED
P210U18	J32-V	3	K12-5	4	1	9.50	RED
P59A18	K12-4	4	K16-7	4	1	3.00	RED
P71A18	K12-3	4	K11-8	4	1	6.75	RED
P200P18	K12-6	4	TB104-7	4	1	13.50	RED
P200R18	K11-4	4	TB104-7	4	1	15.00	RED
X9F18C	K11-1	4	TB104-1	4	1	15.75	BLACK
X12EE18	K11-2	4	TB104-3	4	1	16.50	BLACK
X9E18C	K12-1	4	TB104-1	4	1	16.25	BLACK
X12FF18N	K12-2	4	TB104-3	4	1	16.00	BLACK
P50AB18	K16-3	4	TB104-5	4	1	17.00	RED
P55X018	K16-4	4	TB104-6	4	1	17.50	RED
X9S18C	J8-A	2	TB104-2	4	1	7.50	BLACK
X12018N	J8-B	2	TB104-4	4	1	7.50	BLACK
P55S18	J8-D	2	TB104-6	4	1	8.50	RED
K103A18	J8-N	2	TB106-1	4	1	9.00	BLACK
K104A18	J8-T	2	TB106-3	4	1	8.00	BLACK
K108A18	J8-P	2	TB106-5	4	1	7.50	BLACK
K109A18	J8-R	2	TB106-6	4	1	7.00	BLACK
K105A18	J8-E	2	R28-R	6	1	5.50	BLACK
K106A18	J8-H	2	P28-M	6	1	6.50	BLACK
K107A18	J8-F	2	R28-L	6	1	6.75	BLACK
K114A18	S10-3	4	J8-K	2	1	6.85	BLACK
K115A18	S10-4	4	J8-L	2	1	6.50	BLACK
K144A18	S10-1	4	K12-7	4	1	8.00	BLACK
K145A18	S10-2	4	K12-8	4	1	8.25	BLACK

NOTES:

- ALL SOLDERED CONNECTIONS SHALL BE IN ACCORDANCE WITH MIL-STD-454, REQUIREMENT 5.
- CUT INSULATION SLEEVING (FIND #9) INTO 38 PIECES, .750 INCHES LONG AND INSTALL OVER WIRES AND PINS, AFTER SOLDERING, TO THE CONNECTORS (FIND #2 AND #3). THEN APPLY HEAT OF 400°F FOR 3-5 SEC. FOR PROPER SHRINKAGE.
- INSTALL STRAPS, FIND NO. 7 AT 3.0 MAX INTERVALS AND AT EACH CABLE BREAK-OUT.
- WIRE MARKING TO BE IN ACCORDANCE WITH MIL-W-5088 EXCEPT THAT LENGTH BETWEEN GROUPS OF NUMBERS SHALL NOT EXCEED 6 INCHES.
- CRIMPED TERMINALS SHALL MEET THE PERFORMANCE REQUIREMENTS OF MIL-T-7928.
- INTERPRET DRAWING PER MIL-STD-100.
- REFERENCES
  - FOR WIRING DIAGRAM, SEE DRAWING 72-2205.
  - FOR SCHEMATIC DIAGRAM, SEE DRAWING 72-2200 AND 72-2269.

9				M23053/5-105-0	28 1/2"	INSULATION SLEEVING	MIL-1-23053/5	
8								
7				MS3387-5-9	AR	STRAP, CABLE ADJUSTABLE		
6				MS25036-149	4	TERMINAL LUG NO. 8 STUD, 18 AWG (NOT USED)		
5								
4				MS25036-102	46	TERMINAL LUG NO. 6 STUD, 18 AWG		
3				MS3102R24-28P	1	CONNECTOR ELECTRIC, J32		
2				MS3102R24-28S	1	CONNECTOR ELECTRIC, J8		
1				MS086/2-18-9	AR	WIRE ELECTRIC 18 AWG	MIL-W-5086/2	
FIND NO.	SYM	CODE IDENT	DWG SIZE	PART OR IDENTIFYING NO.	QTY REQD	NOMENCLATURE OR DESCRIPTION	SPECIFICATION	MATERIAL

ME5-6115-465-34/5-28(1)

Figure 5-28. 50/60 Hz Precise Relay Assembly Wiring Harness, Drawing No. 72-2242 (Sheet 1 of 2)

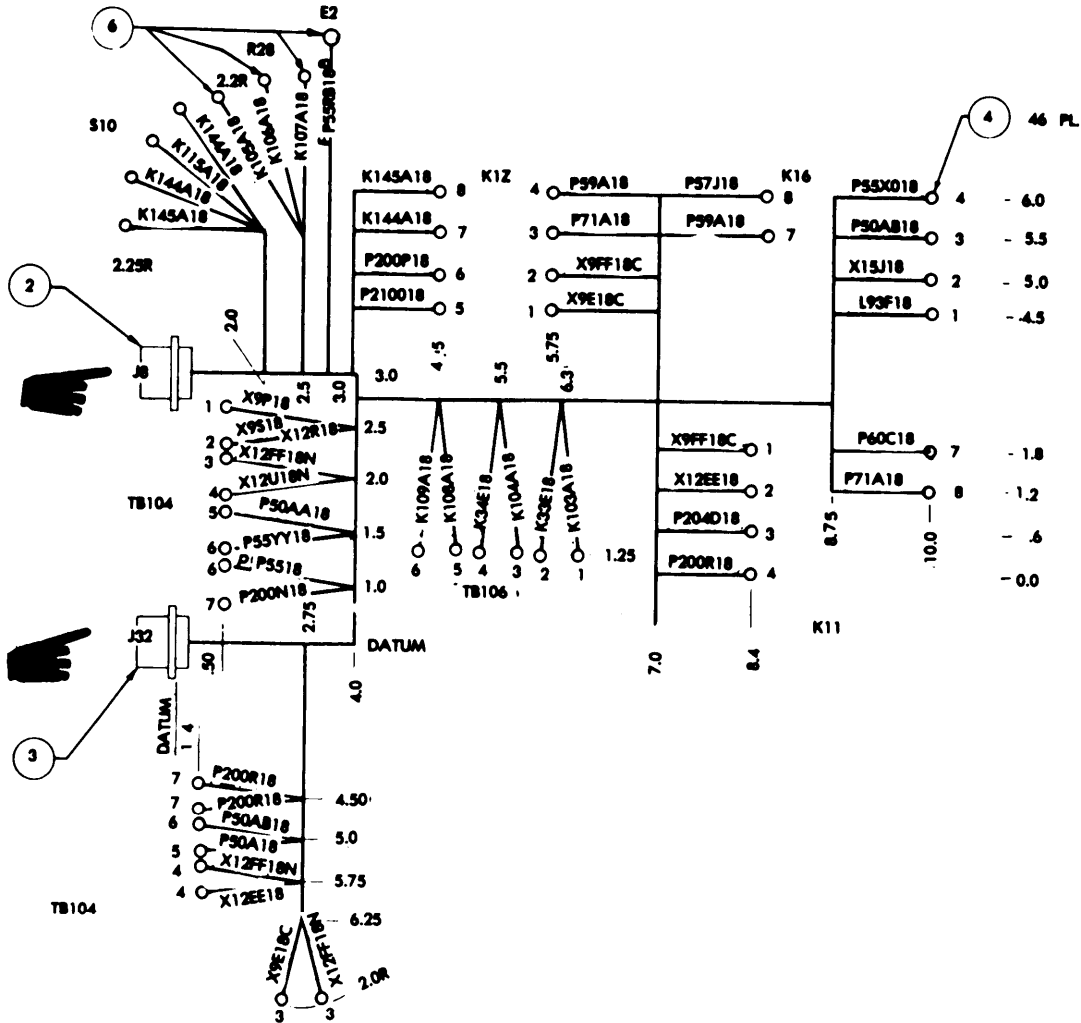

ME5-6115-465-34/5-28(2)

Figure 5-28. 50/60 Hz Precise Relay Assembly Wiring Harness, Drawing No. 72-2242 (Sheet 2 of 2)



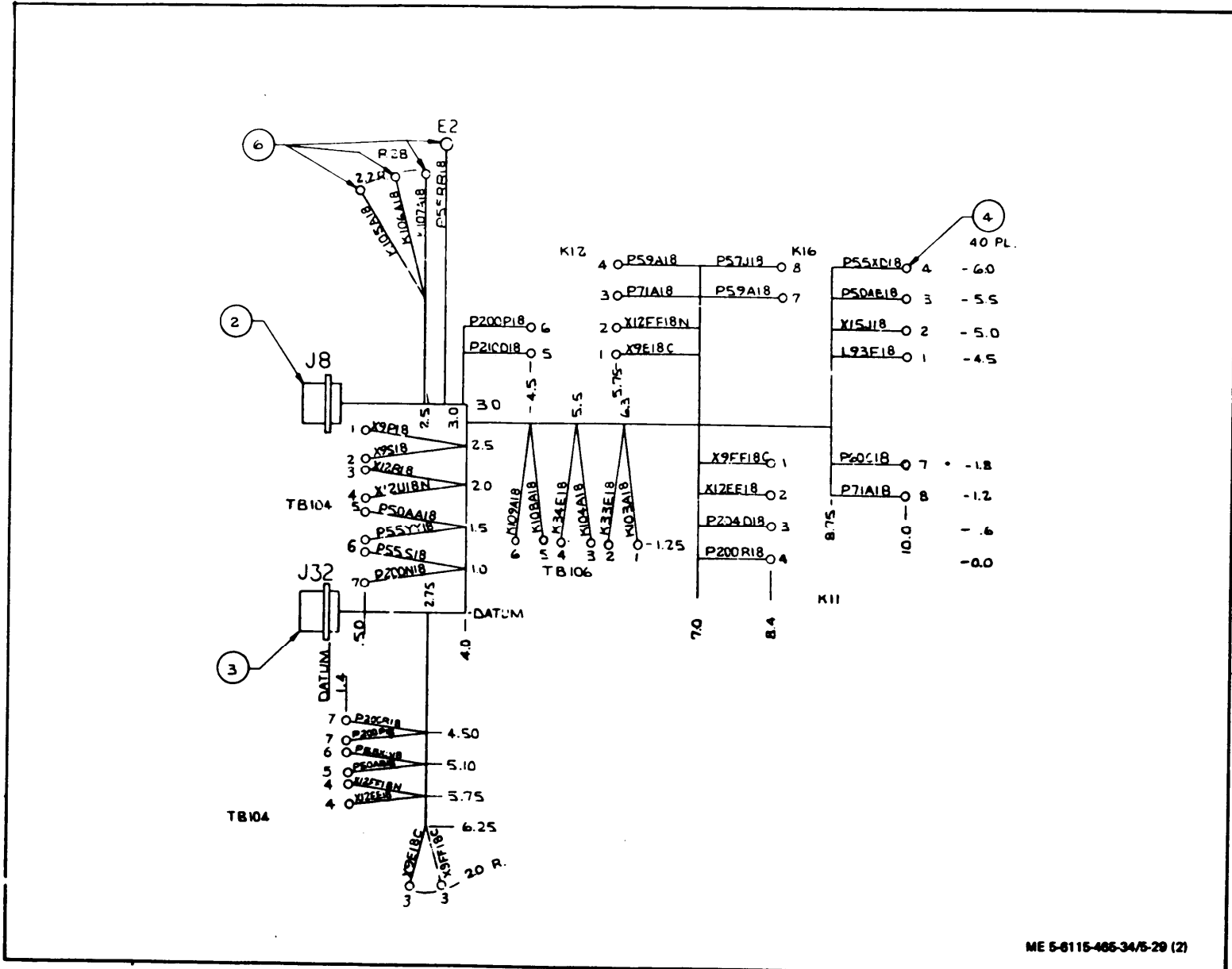
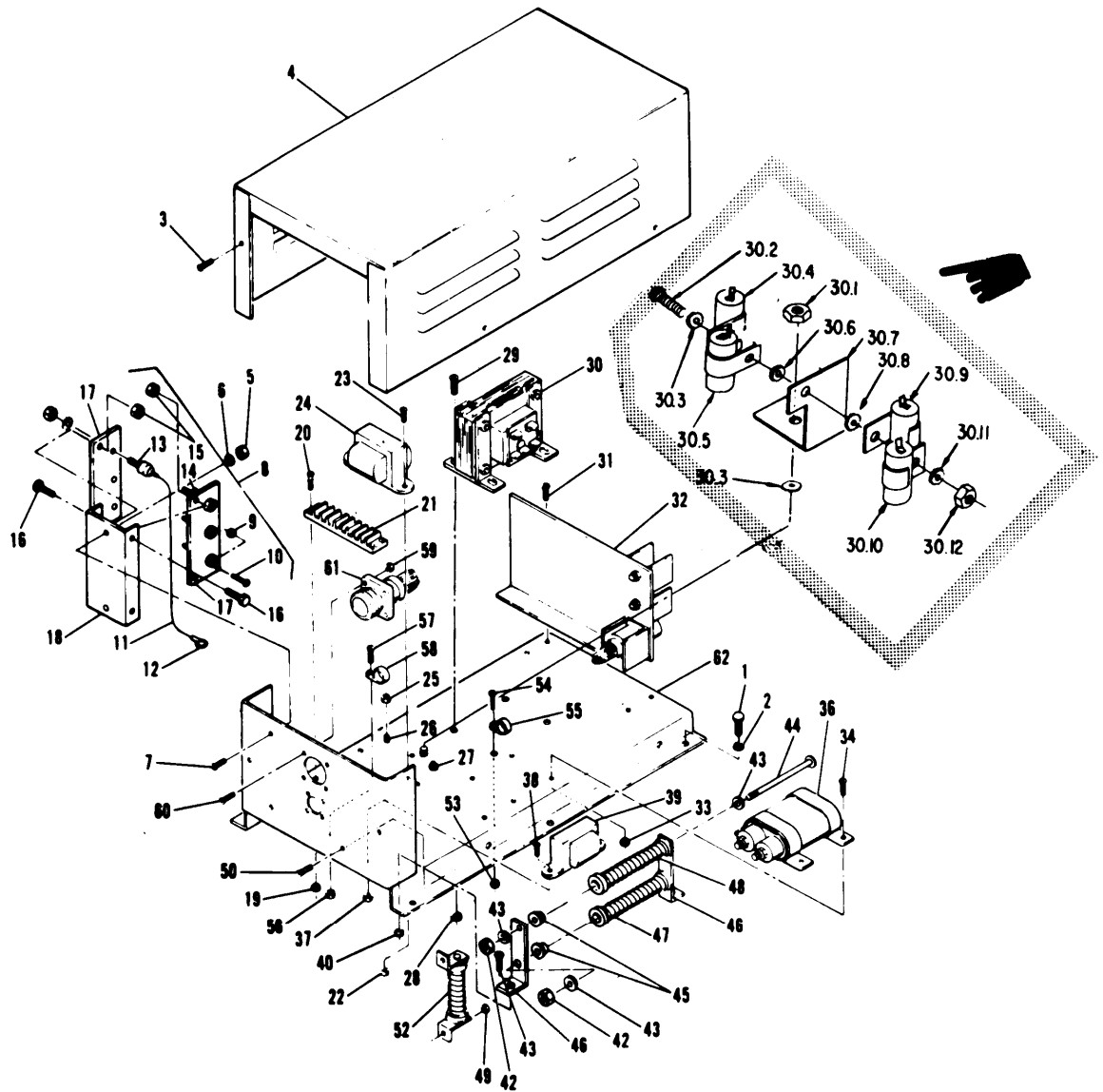

Figure 5-29. 400 Hz Precise Relay Assembly Wiring Harness, Drawing No. 72-2260 (Sheet 2 of 2)





ME5-6115-465-34/5-30(1)

Figure 5-30. Static Exciter and Voltage Regulator Assembly, Exploded View  
(Sheet 1 of 3)

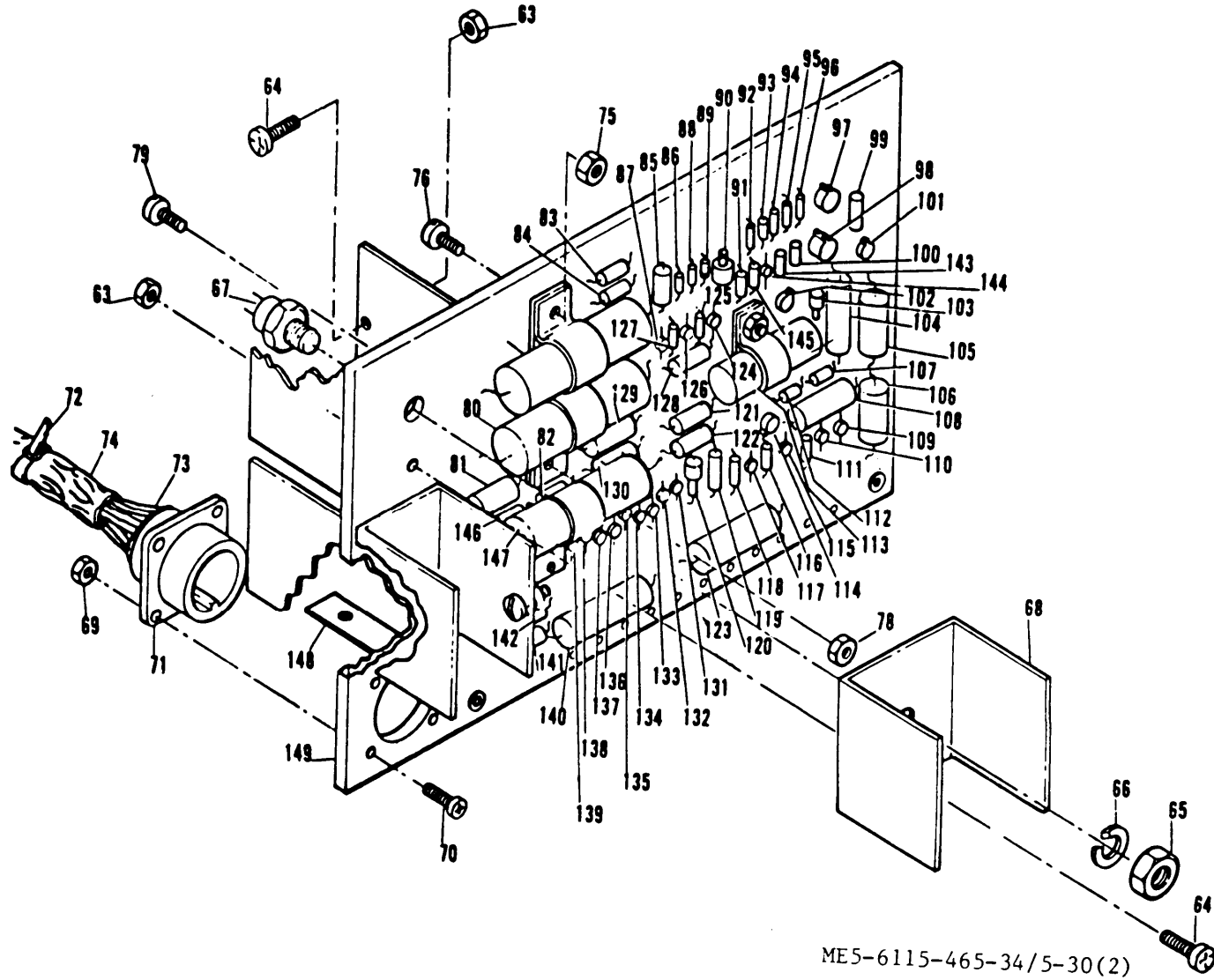

ME5-6115-465-34/5-30(2)

Figure 5-30. Static Exciter and Voltage Regulator Assembly, Exploded View (Sheet 2 of 3)

1.	Screw	42.	Nut & captive washer assy	96.	Capacitor C3
2.	Lockwasher	43.	Washer	97.	Transistor
3.	Screw	44.	Screw	98.	Integrated circuit
4.	Chassis cover	45.	Mica washer	99.	Resistor R14
5.	Nut & captive washer assy	46.	Mounting bracket	100.	Resistor
6.	Flat washer	47.	Resistor R1	101.	Transistor
7.	Screw	48.	Resistor R2	102.	Transistor
8.	Heat sink assy	49.	Nut & captive washer assy	103.	Zener diode
9.	Nut & captive washer assy	50.	Screw	104.	Capacitor C8
10.	Screw	51.	Resistor bracket	105.	Resistor R5
11.	Wire	52.	Resistor R3	106.	Resistor A4
12.	Terminal lug	53.	Nut & captive washer assy	107.	Resistor R23 (400 Hz only)
13.	Semiconductor	54.	Screw	108.	Capacitor C7 (400 Hz only)
14.	Semiconductor	55.	Cable clamp	109.	Diode
15.	Nut & captive washer assy	56.	Nut & captive washer assy	110.	Diode
16.	Screw	57.	Screw	111.	Resistor R 18
17.	Heat sink	58.	Cable clamp	112.	Resistor R22 (400 Hz only)
18.	Heat sink support	59.	Nut & captive washer assy	113.	Capacitor C1 5
19.	Nut & captive washer assy	60.	Screw	114.	Transistor
20.	Screw	61.	Wiring harness	115.	Diode
21.	Terminal board	62.	Chassis	116.	Resistor R19
22.	Nut & captive washer assy	63.	Nut & captive washer assy	117.	Diode
23.	Screw	64.	Screw	118.	Resistor R20
24.	Transformer	65.	Nut	119.	Capacitor C5 (400 Hz only)
25.	Nut & captive washer assy	66.	Lockwasher	120.	Zener diode
26.	Terminal	67.	Diode CR1	121.	Resistor R9 (400 Hz only)
27.	Nut & captive washer assy	68.	Heat sink	122.	Resistor R29
28.	Nut & captive washer assy	69.	Nut & captive washer assy	123.	Resistor R25
29.	Screw	70.	Screw	124.	Diode
30.	Transformer	71.	Wiring harness	125.	Resistor R33
30.1	Nut	72.	Tiedown strap wire	126.	Diode
30.2	Screw	73.	Wire	127.	Resistor R15
30.3	Lockwasher	74.	Shrink tubing	128.	Resistor R32
30.4	Capacitor	75.	Nut & captive washer assy	129.	Resistor R17
30.5	Capacitor	76.	Screw	130.	Capacitor C9
30.6	Lockwasher	77.	Capacitor C14	131.	Diode
30.7	Bracket	78.	Nut & captive washer assy	132.	Diode
30.8	Lockwasher	79.	Screw	133.	Diode
30.9	Capacitor	80.	Capacitor C13	134.	Diode
30.10	Capacitor	81.	Resistor R24	135.	Diode
30.11	Lock washer	82.	Resistor R16	136.	Diode
30.12	Nut	83.	Resistor R21	137.	Diode
31.	Screw	84.	Resistor R28	138.	Diode
32.	Voltage regulator assy	85.	Capacitor C16	139.	Diode
33.	Nut & captive washer assy	86.	Resistor R31	140.	Capacitor C1 1
34.	Screw	87.	Diode CR11	141.	Resistor R26
35.	Mounting bracket	88.	Resistor R30	142.	Resistor R27
36.	Capacitor C2	89.	Resistor R11	143.	Resistor R13
37.	Nut & captive washer assy	90.	Zener diode	144.	Diode
38.	Screw	91.	Resistor R6	145.	Resistor R8
39.	Transformer	92.	Resistor R10	146.	Capacitor C10 (50/60 Hz only)
40.	Nut & captive washer assy	94.	Capacitor C6	147.	Capacitor C12 (50/60 Hz only)
41.	Screw	95.	Resistor R12	148.	Mounting bracket
				149.	Printed circuit board

ME5-6115-465-34/5-30(3)

Figure 5-30. Static Exciter and Voltage Regulator Assembly, Exploded View (Sheet 3 of 3)

TM5-6115-465-34  
 TO35C2-3-446-2  
 NAVFACP-8-625-34  
 TM068578B/06859-D-34

NOTES:

1. INTERPRET DRAWING PER MIL-STD-100.

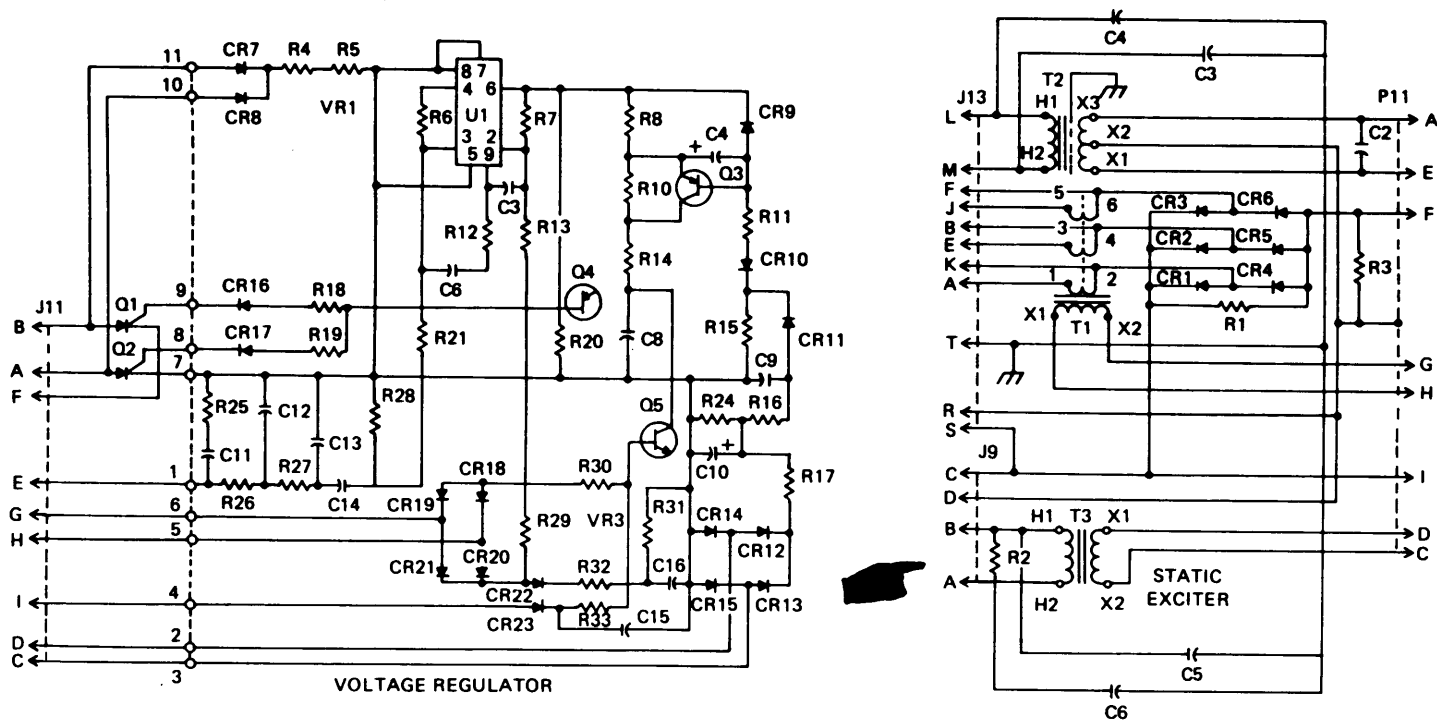

Figure 5-31. 50/60 Hz Static Exciter and Voltage Regulator Schematic Diagram, Drawing No. 72-2629

(b) One direction shall give an indication of less than 100 ohms. The other direction shall give an indication of one megohm or more. There shall be no indication of discontinuity in either direction.

(c) Replace defective semiconductors.

(5) Inspect terminal board assembly for cracks, burns, and corroded terminals. Replace defective terminal board assembly.

(6) Inspect transformers for cracks, corrosion, and evidence of shorting or overheating. Check continuity of coils using an ohmmeter. There shall be no sign of open circuit.

(7) Replace defective transformers.

(8) Inspect voltage regulator assembly for burned or damaged components.

(9) Electrically check voltage regulator assembly components using figure 5-31 or 5-32 as a guide. Refer to table 5-1 for capacitance and resistance value of components.

(10) If any voltage regulator components must be replaced or encapsulating coating repaired or replaced, refer to Appendix A references for detailed procedures. Repair/replace encapsulation by applying 0.020 inch (rein) coating of polyurethane resin (scotchcast 221, Minnesota Mining and Mfg. Co. or equal).

(11) Inspect wiring harness for damaged connectors and terminals, burns, broken wires, and other damage.

(12) Check individual wires for continuity using figure 5-33 as a guide.

(13) If the wiring harness has sustained damage and requires repair or rebuild, refer to figure 5-33 for layout, identification and material requirements and Appendix A references for detailed soldering and replacement procedures.

e. Assembly. Assemble static exciter and voltage regulator assembly in reverse order of removal procedures.

f. Testing.

(1) Perform sensing circuit bench test as follows :

#### NOTE

The chassis cover (4, figure 5-30) must be removed to perform the bench test.

(a) Connect static exciter and voltage regulator assembly into test circuit shown in figure 5-34.

(b) Adjust power source until VI shows 95 Vac (any frequency between 50 and 400 Hz).

(c) Check for 22 Vdc across R15 (connect voltmeter V2, positive side to cathode of CR 11, and negative side to heat sink where CR4-CR6 are mounted).

(2) Conduct power circuit bench test as follows:

(a) Install static exciter and voltage regulator assembly into test circuit shown in figure 5-35.

(b) Adjust power source to 208 Vac at the rated frequency of the unit as indicated on voltmeter V 1.

**(c) For 400 Hz units only apply 50-76 Vat, 400 Hz to terminals A and B of connector J9.**

**(d) Voltmeter V2 should indicate 48 Vdc**

(3) Conduct boost circuit bench test as follows:

(a) With chassis cover (4, figure 5-30) removed, connect positive lead of voltmeter to heat sink where CR 1-CR3 are mounted. Connect negative lead to heat sink where CR4-CR6 are mounted. (See item 17, figure 5-30).

(b) Apply 12 Vac (any frequency between 50 and 400 Hz) to pins A and B of connector J13.

(c) Voltmeter connected across heat sinks should indicate 9.3 Vdc.

(d) Remove 12 Vac from pins A and B and connect to E and F, then to J and K. In each case, voltmeter should indicate 9.3 Vdc.

(4) If the requirements of any test are not met, check components using figure 5-31 or 5-32 and table 5-1 as a guide to locate the malfunction. Correct before installing the static exciter and voltage regulator assembly.

g. Installation. Install static exciter and voltage regulator assembly in reverse order of removal procedures.

#### 5-14. RELAY TABLE COMPONENTS ADJUSTMENTS.

a. General. After maintenance has been performed on any of the relay table components, the appropriate adjustments shall be performed.

b. Voltage Adjustment.

Table 5-1. STATIC EXCITER AND VOLTAGE REGULATOR RESISTOR AND CAPACITOR VALUES

COMPONENT	VALUES	
	50/60 Hz	400 Hz
Resistor R1	10 ohm, 55 watt	10 ohm, 55 watt
Resistor R2	510 ohm, 55 watt	510 ohm, 55 watt
Capacitor C2	20 MFD, 400 volt	5 MFD, 400 volt
Resistor R3	510 ohm, 26 watt	510 ohm, 26 watt
Capacitor C14	2.2 MFD, 200 volt	2.2 MFD, 200 volt
Capacitor C13	3.3 MFD, 200 volt	3.3 MFD, 200 volt
Resistor R24	2.4Kohm, 2 watt	2.4K ohm, 2 watt
Resistor R16	15. K ohm, 1/8 watt	1.5K ohm, 1/8 watt
Resistor R21	470K ohm, 1/4 watt	470K ohm, 1/4 watt
Resistor R28	47K ohm, 1/4 watt	47K ohm, 1/4 watt
Capacitor C16	22 MFD, 15 volt	22 MFD, 15 volt
Resistor R31	3.9K ohm, 1/4 watt	3.9K ohm, 1/4 watt
Resistor R30	33K ohm, 1/4 watt	33K ohm, 1/4 watt
Resistor R11	4.99K ohm, 1/8 watt	4.99K ohm, 1/8 watt
Resistor R6	32.4K ohm, 1/8 watt	32.4K ohm, 1/8 watt
Resistor R10	20K ohm, 1/8 watt	30K ohm, 1/8 watt
Capacitor C4	.68 MFD, 50 volt	
Capacitor C6	0.22 MFD, 50 volt	0.22 MFD, 50 volt
Resistor R12	2.2M ohm, 1/4 watt	2.2M ohm, 1/4 watt
Capacitor C3	0.0001 MFD, 200 Volt	0.0001 mfd, 200 volt
Resistor R14	470 ohm, 1/2 watt	470 ohm, 1/2 watt
Resistor R7	49.9K ohm, 1/8 watt	49.9K ohm, 1/8 watt
Capacitor C8	0.33 MFD, 50 volt	0.1 mfd, 50 volt
Resistor R5	750 ohm, 2 watt	750 ohm, 2 watt
Resistor R4	750 ohm, 2 watt	750 ohm, 2 watt
Resistor R23		100 ohm, 1/4 watt
Capacitor C7		0.047 mfd, 50 volt
Resistor R18	10 ohm, 1/4 watt	10 ohm, 1/4 watt
Resistor R22		2.2K ohm, 1/4 watt
Capacitor C15	2.2 MFD, 200 volt	2.2 mfd, 200 volt
Resistor R19	10 ohm, 1/4 watt	10 ohm, 1/4 watt
Resistor R20	39 ohm, 1/4 watt	39 ohm, 1/4 watt
Capacitor C5		0.10 mfd, 20 volt
Resistor R9		10K ohm, 1 watt
Resistor R29	1K ohm, 1 watt	1K ohm, 1 watt
Resistor R25	150 ohm, 2 watt	150 ohm, 2 watt
Resistor R33	33K ohm, 1/4 watt	33K ohm, 1/4 watt
Resistor R15	49.9K ohm, 1/8 watt	49.9K ohm, 1/8 watt
Resistor R32	2.7K ohm, 1 watt	2.7K ohm, 1 watt
Resistor R17	5.1K ohm, 2 watt	5.1K ohm, 2 watt
Capacitor C9	4.7 MFD, 50 volt	4.7 mfd, 50 volt
Capacitor C11	0.1 MFD, 200 volt	0.1 mfd, 200 volt
Resistor R26	18K ohm, 1 watt	5.1K ohm, 1 watt
Resistor R27	10K ohm, 1 watt	10K ohm, 1 watt
Resistor R13	20K ohm, 1/8 watt	20K ohm, 1/8 watt
Resistor R8	100 ohm, 1/4 watt	100 ohm, 1/4 watt
Capacitor C10	4.7 MFD, 50 volt	
Capacitor C12	3.3 MFD, 200 volt	
Capacitor C3	.01 MFD, 500 Volt AC/DC	
Capacitor C4	.01 MFD, 500 Volt AC/DC	
Capacitor C5	.01 MFD, 500 Volt AC/DC	
Capacitor C6	.01 MFD, 500 Volt AC/DC	

NOTES  
 1. INTERPRET DRAWING PER MIL-STD-100

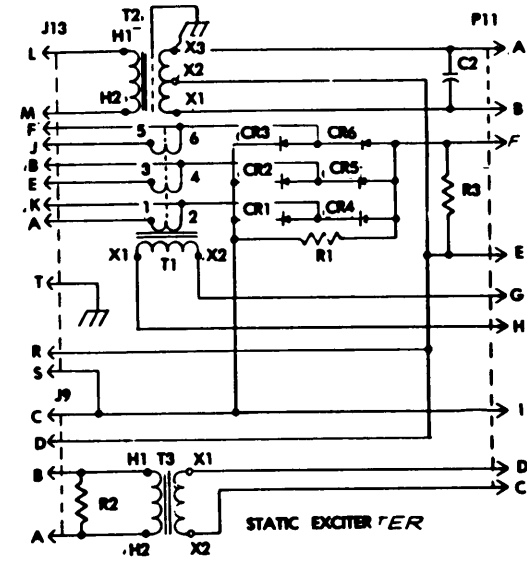
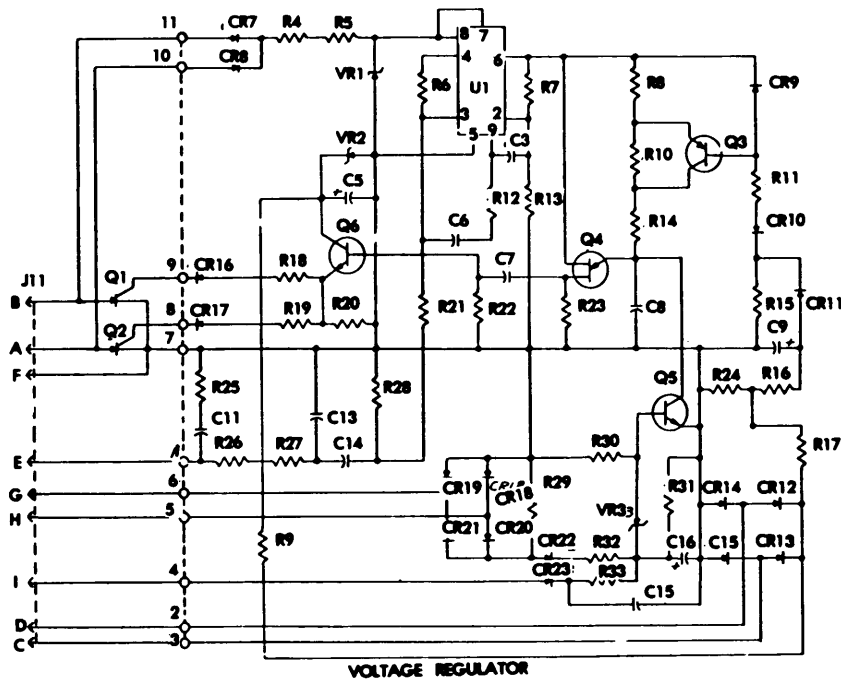

ME5-6115-465-34/5-32

Figure 5-32.400 Hz Static Exciter and Voltage Regulator Schematic Diagram, Drawing No. 72-2630

X12KK18	T2-H3		C3	10	6	4.50
X9Z18	T2-H1		C4	10	6	4.50
X197JJ18	T3-H1		C5	10	6	4.50
X91G18	T3-H2		C6	10	6	4.50
X1B18	J13-A	3	T81-B	4	6	12.75
X2B18	J13-B	3	T81-4	4	6	11.50
X3B18	J13-E	3	T81-7	4	6	12.50
X4B18	J13-F	3	T81-3	4	6	10.75
X5B18	J13-J	3	T81-6	4	6	12.25
X9W18	J13-L	3	T2-H1		6	21.25
X10B18	J13-K	3	T81-5	4	6	11.75
X12JJ18	J13-M	3	T2-H2		6	22.50
X24A18	P11-C	2	T3-X2		6	17.75
X25A18	P11-D	2	T3-X1		6	17.25
X27A18	P11-H	2	T1-X1		6	19.00
X28A18	P11-G	2	T1-X2		6	18.00
X91E18	J9-A	1	R2-2		6	14.00
X91F18	R2-2		T3-H2		6	5.00
X197H18	J9-B	1	R2-1		6	10.50
X197G18	R2-1		T3-H1		6	4.00
D11C18	J9-C	1	T81-1	4	6	7.00
D11D18	P11-I	2	T81-1	4	6	14.75
D11E18	T81-1	4	R1-1		6	9.00
D11F18	HS2	4	R1-1		6	10.50
D11G18	J13-S	3	T81-1	4	6	10.50
D12C18	J9-D	1	T81-2	4	6	7.25
D12D18	T81-2	4	T2-X2		6	12.00
D12E18	P11-E	2	T2-X2		6	15.00
D12F18	T81-2	4	R3-1		6	12.25
D12G18	J13-R	3	T81-2	4	6	10.50
P3A18	HS1	4	R3-2		6	7.50
P3B18	R3-2		R1-2		6	11.50
P3C18	P11-F	2	R1-2		6	17.25
P4A18	C2-1	5	T2-X3		6	8.25
P4B18	P11-B	2	C2-1	5	6	10.00
P5A18	C2-2	5	T2-X3		6	9.50
P5B18	P11-A	2	C2-2	5	6	10.00
P55BB18	J13-Y	3	T2	5	6	14.75
WIRE NO	FROM	FIND NO REF	TO	FIND NO REF	WIRE FIND NO	WIRE LENGTH REF
TERMINATION						
RUNNING WIRE LIST						

NOTES:

1. ALL SOLDERED CONNECTIONS SHALL BE IN ACCORDANCE WITH MIL-STD-454, REQUIREMENT 5.
2. CUT INSULATION SLEEVING, FIND NO. 7, INTO 24 PIECES, .750 INCHES LONG AND INSTALL OVER WIRES AND PINS, AFTER SOLDERING, TO THE CONNECTORS, FIND NOS. 3, 2, AND 1. THEN APPLY HEAT OF 400°F FOR 3-5 SEC. FOR PROPER SHRINKAGE.
3. INSTALL STRAPS, FIND NO. 9, AT APPROXIMATELY 2.5 INTERVALS AND AT EACH WIRE BREAKOUT.
4. WIRE MARKING TO BE IN ACCORDANCE WITH MIL-W-5088 EXCEPT THAT LENGTH BETWEEN GROUPS OF NUMBERS SHALL NOT EXCEED 6 INCHES.
5. INTERPRET DRAWING PER MIL-STD-100.
6. CRIMPED TERMINAL SHALL MEET THE PERFORMANCE REQUIREMENTS OF MIL-T-7928.
7. INSTALL END SEAL PLUGS, FIND NO. 8, IN UNUSED HOLES OF CONNECTORS, FIND NOS. 1, 2, AND 3.
8. REF: CONNECTION DIAGRAM 72-2631  
SCHEMATIC DIAGRAM 72-2630 AND 72-2629
9. ALL WIRES WITHOUT TERMINAL LUGS SHALL BE STRIPPED .25 FROM THE END AND TINNED IN ACCORDANCE WITH MIL-STD-454, REQUIREMENT 5.

10				MS25036-149		LUG TERMINAL NO. 8	
9				MS3367-4-9	AR	STRAP, ADJUSTABLE	MIL-S-23190
8				MS25251-16	11	PLUG, END SEAL	MIL-C-50 15
7				M23053/5-105-0	18 <sup>M</sup>	INSULATION, SLEEVING	MIL-I-23053/5
6				MS086/2-18-9	AR	WIRE, NO. 18 AWG, WHITE	MIL-W-5086/2
5				MS15036-150	5	LUG TERMINAL NO. 1/4	
4				MS25036-102	16	LUG TERMINAL NO. 6	
3				MS3102R22-14P	1	CONNECTOR J13	MIL-C-5015
2				MS3106R18-1P	1	CONNECTOR P11	MIL-C-5015
1				MS3102R14S-6P	1	CONNECTOR J9	MIL-C-5015
FIND NO.	SYM:	CODE IDENT	DWG SIZE	PART OR IDENTIFYING NO	QTY REQD	NOMENCLATURE OR DESCRIPTION	SPECIFICATION MATERIAL
LIST OF MATERIAL							

A. STATIC EXCITER WIRING HARNESS (Shoot 1 of 2)

ME5-6115-465-34/5-33(1)

Figure 5-33. Static Exciter Wiring Harness, Dwg. No. 72-2628, Voltage Regulator Wiring Harness, Dwg. No. 72-2627, and Static Exciter connection wiring Diagram, Dwg. No. 72-2631 (Sheet 1 of 4)





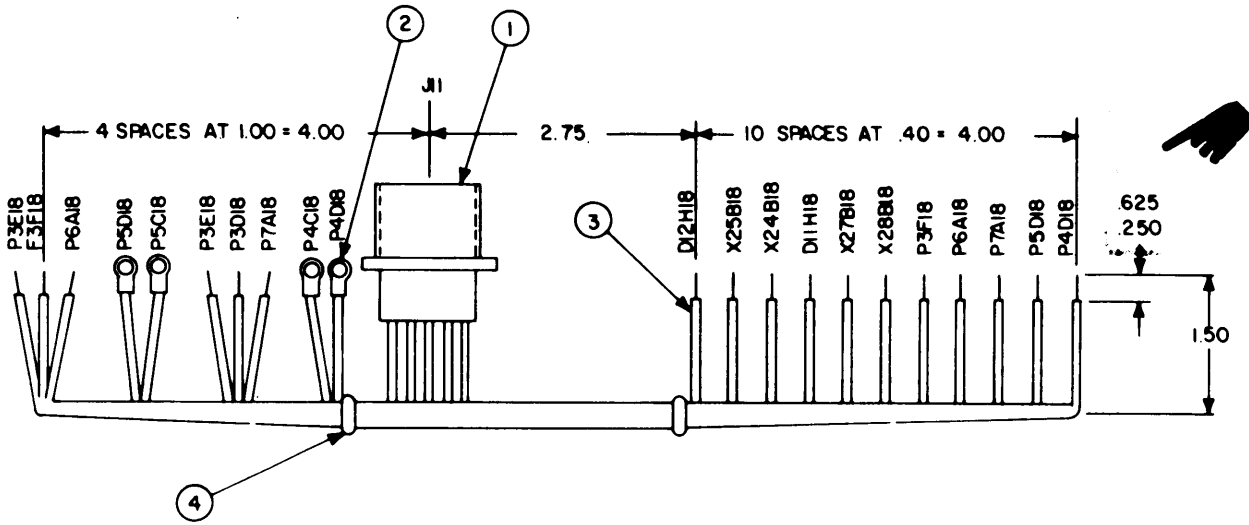

NOTES:

1. ALL SOLDERED CONNECTIONS SHALL BE IN ACCORDANCE WITH MIL-STD-454, REQUIREMENT NO. 5.
2. CUT INSULATION SLEEVING, FIND NO. 5, INTO 9 PIECES, .750 INCHES LONG AND INSTALL OVER WIRES AND PINS, AFTER SOLDERING, TO THE CONNECTOR, FIND NO. 1. THEN APPLY HEAT OF 400°F FOR 3-5 SEC. FOR PROPER SHRINKAGE.
3. INSTALL STRAPS, FIND NO. 4, AT 3.00 MAX INTERVALS AND AT EACH CABLE BREAK-OUT.
4. WIRE MARKING TO BE IN ACCORDANCE WITH MIL-W-5086 EXCEPT THAT LENGTH BETWEEN GROUPS OF NUMBERS SHALL NOT EXCEED 6 INCHES.
5. CRIMPED TERMINALS SHALL MEET THE PERFORMANCE REQUIREMENTS OF MIL-T-792H.
6. REFERENCES:
  - A. CONNECTION DIAGRAM: SEE 72-2631.
  - B. SCHEMATIC DIAGRAM: 72-2629, FOR 50/60 HZ.  
72-2650, FOR 400 HZ.

WIRE MARKING	FROM	FIND NO. REF.	TERMINATION	TO	FIND NO. REF.	WIRE FIND NO. REF.	WIRE LENGTH REF.
P5D1B	Q2-A	2	PCB-10	-	-	3	12.75
P6A1B	Q2-G	-	PCB-B	-	-	-	12.00
P3F1B	Q2-C	-	PCB-7	-	-	-	11.50
P3E1B	Q1-C	-	Q2-C	-	-	-	4.75
P4D1B	Q1-A	2	PCB-11	-	-	-	11.12
P7A1B	A1-G	-	PCB-9	-	-	-	10.62
J11H1B	J11-I	1	PCB-4	-	-	-	6.50
X27B1B	J11-H	-	PCB-5	-	-	-	7.12
X28B1B	J11-G	-	PCB-6	-	-	-	7.50
P3D1B	J11-F	-	Q1-C	-	-	-	4.00
D12H1B	J11-E	-	PCB-1	-	-	-	5.50
X25B1B	J11-D	-	PCB-2	-	-	-	5.75
X24B1B	J11-C	-	PCB-3	-	-	-	6.18
P4C1B	J11-B	-	Q1-A	2	-	-	4.50
P5C1B	J11-A	1	Q2-A	2	3	-	6.62

WIRE RUNNING LIST

FIND NO.	SY.	CODE IDENT.	DWG SIZE	PART OR IDENTIFYING NO.	QTY REQD.	NOMENCLATURE OR DESCRIPTION	SPECIFICATION	MATERIAL
5				M23053/5-105-0	6.75"	INSULATION SLEEVING	MIL-T-23053/5	
4				MS3367-4-9	AR	STRAP, TIEDOWN ADJ.		
3				MS086/2-18-9	AR	WIRE, ELECT 18AWG	MIL-W-5086/2	
2				MS25036-102	4	TERMINAL LUG NO. 6 STUD SIZE		
1				MS3102R18-1S	1	CONNECTOR (J11)		

C. VOLTAGE REGULATOR WIRING HARNESS

ME5-6115-465-34/5-33(3)

Figure 5-33. Static Exciter Wiring Harness, Dwg. No. 72-2628, Voltage Regulator Wiring Harness, Dwg. No. 72-2627, and Static Exciter Connection Wiring Diagram, Dwg. No. 72-2631 (Sheet 3 of 4)

TM5-6115-465-34  
 NAVFAC P-8-625-34  
 T. O.35C2-3-446-2  
 TM06858B/06859D-34

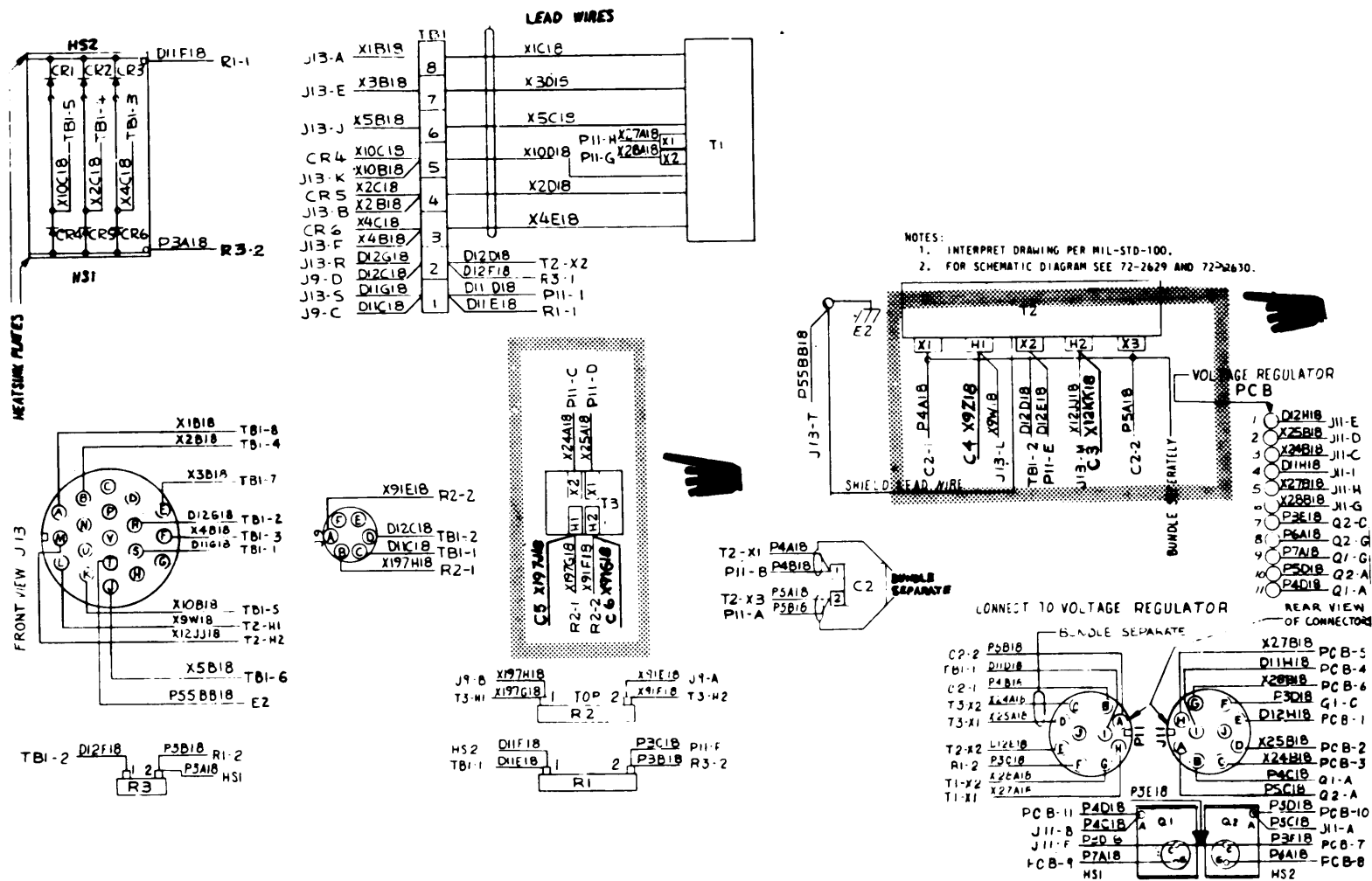

D. Static Exciter Connection Wiring Diagram

Figure 5-33. Static Exciter Wiring Harness, Dwg. No. 72-2628, Voltage Regulator Wiring Harness, Dwg. No. 72-2627, and Static Exciter Connection Wiring Diagram, Dwg. No. 72-2631 (Sheet 4 of 4)

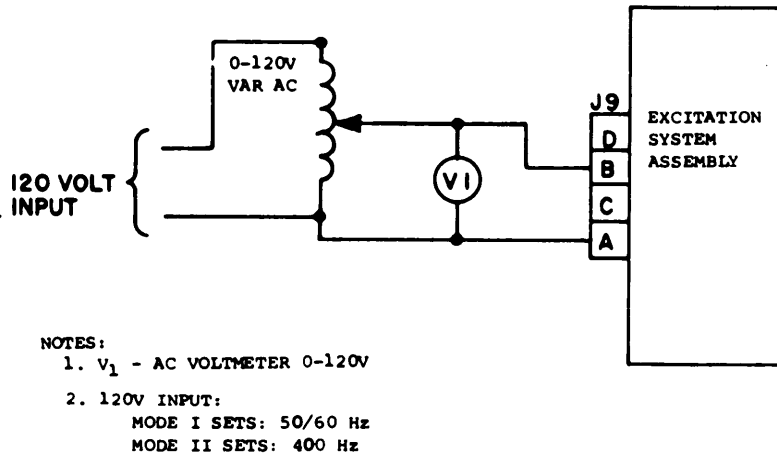

ME5-6115-465-34/5-34

Figure 5-34. Static Exciter and Voltage Regulator Assembly Sensing Circuit Bench Test

NOTES:

1.  $V_1$  - AC VOLTMETER 0-250V
2.  $V_2$  - DC VOLTMETER 0-50V
3. 208V INPUT:  
 MODE I SETS: 50/60 Hz  
 MODE II SETS: 400 Hz

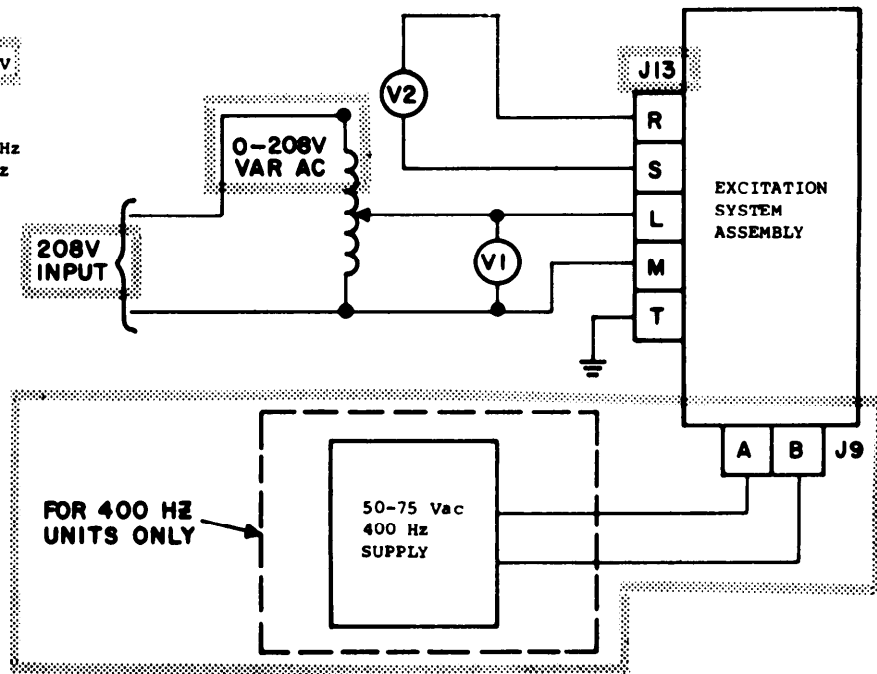

ME5-6115-465-34/5-35

Figure 5-35. Static Exalter and Voltage Regulator Assembly Power Circuit Bench Test

[1] Position voltage adjust rheostat R2 on generator set control cubicle to the approximate midpoint.

[2] Refer to the Operator and Organizational Maintenance Manual and start the generator set.

[3] Adjust voltage rheostat variable resistor R2 to obtain generator assembly rated voltage.

c. Paralleling Adjustments.

[1] Refer to the Operator and Organizational Maintenance Manual and connect a rated load to the generator set load terminal board.

[2] Start the generator set and operate at Full rated load.

**(3) Install the shorting plug in the paralleling receptacle.**

(4) Place the operation switch on the generator set control cubicle in the PARALLEL position.

(5) Adjust reactive current adjust potentiometer R29 of the special relay assembly to provide a special droop of 3 percent.

(6) Adjust the load sharing adjust rheostat (R28) of the precise relay assembly until 4 to 6 volts appear across pins A and B of the paralleling receptacle.

**NOTE**

Step (6) pertains to precise generator sets only.

(7) Refer to the Operator and Organizational Maintenance Manual and shut down the generator set.

Section IV. GENERATOR ASSEMBLIES

5-15. GENERAL.

**This section contains maintenance procedures for the generator assemblies. There are two types of generators used in the generator set. The 50/60 Hz generator is used in both the 50/60 Hz utility, and 50/60 Hz precise generator sets. The 400 Hz generator is used only in the 400 Hz precise generator set. Both generators are drip-proof, rotating field, synchronous, brushless, fan cooled units. Mounting for the generator is provided by the generator feet bolted to the skid base and the housing bolted to the engine flywheel housing. Rotational power is provided by the blower and coupling assembly which is bolted to the generator rotor shaft and the engine flywheel.**

5-16. GENERATOR MAINTENANCE INSTRUCTIONS.

a. Removal Refer to paragraph 2-7c. for generator removal procedure.

b. Disassembly.

(1) Disassemble generator by following the ascending sequence of index numbers assigned to figure 5-36 only as required to replace damaged or defective components.

(2) Remove screw (1, figure 5-36) and lockwasher (2) to remove drip cover (3).

(3) Remove screws (4) and lockwashers (5) to remove screen guard (6).

(4) Remove screws (7) and lockwashers (8) to remove lead block assembly (9) and gasket (10).

**NOTE**

Tag electrical leads to insure proper positioning at installation loosen clamping screws to relieve tendon on the leads.

(5) Remove screws (11) and lockwashers (12) to remove screen guard (13).

(6) Remove screws (14) and lockwashers (15) to remove cover plate (16).

(7) Remove plug (17), screw (18) and lockwasher (19).

(8) Remove screws (18) and lockwashers (21). Using a suitable puller, remove bearing housing (22).

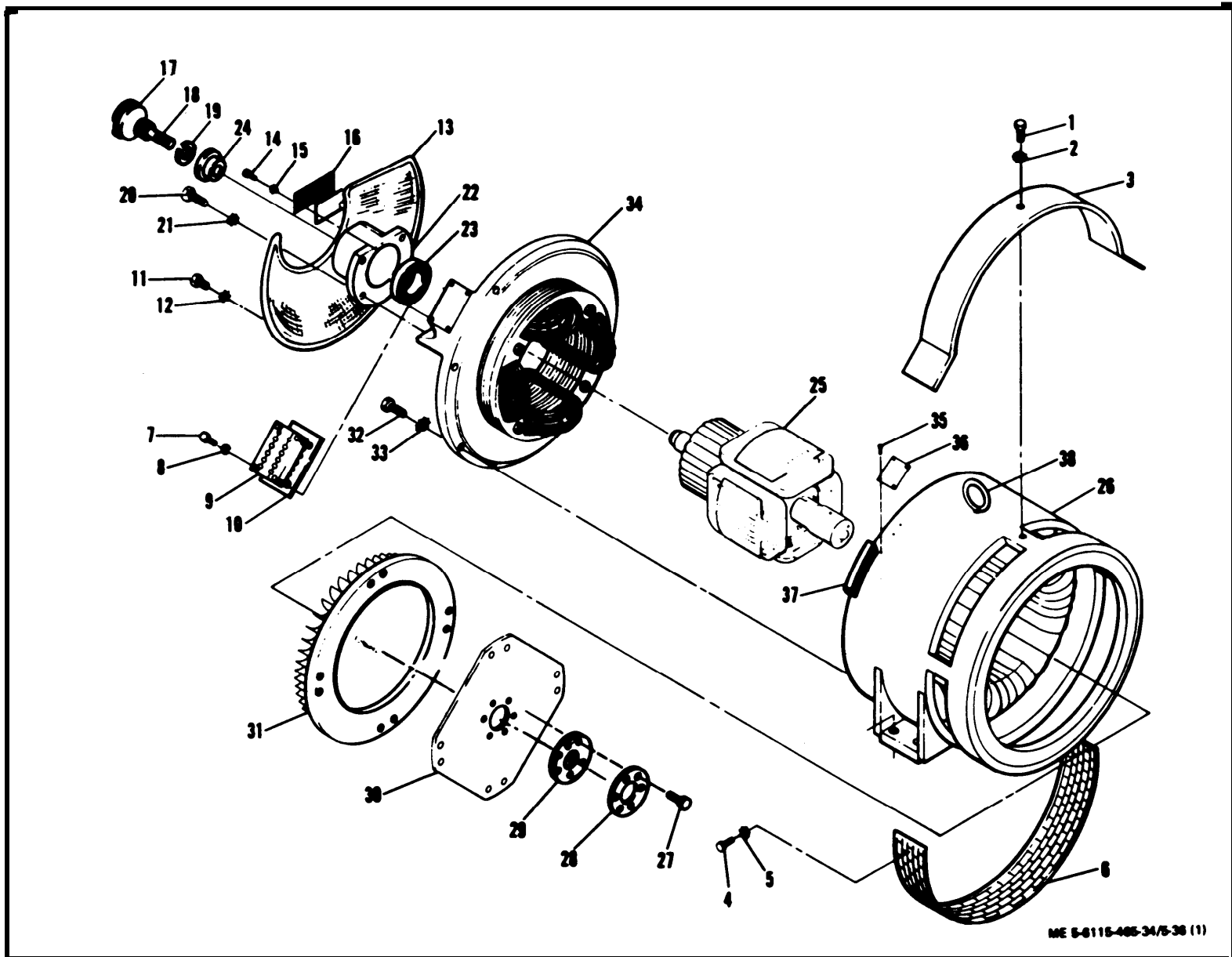

Figure 5-36. Generator Assembly, Exploded View (Sheet 1 of 2)

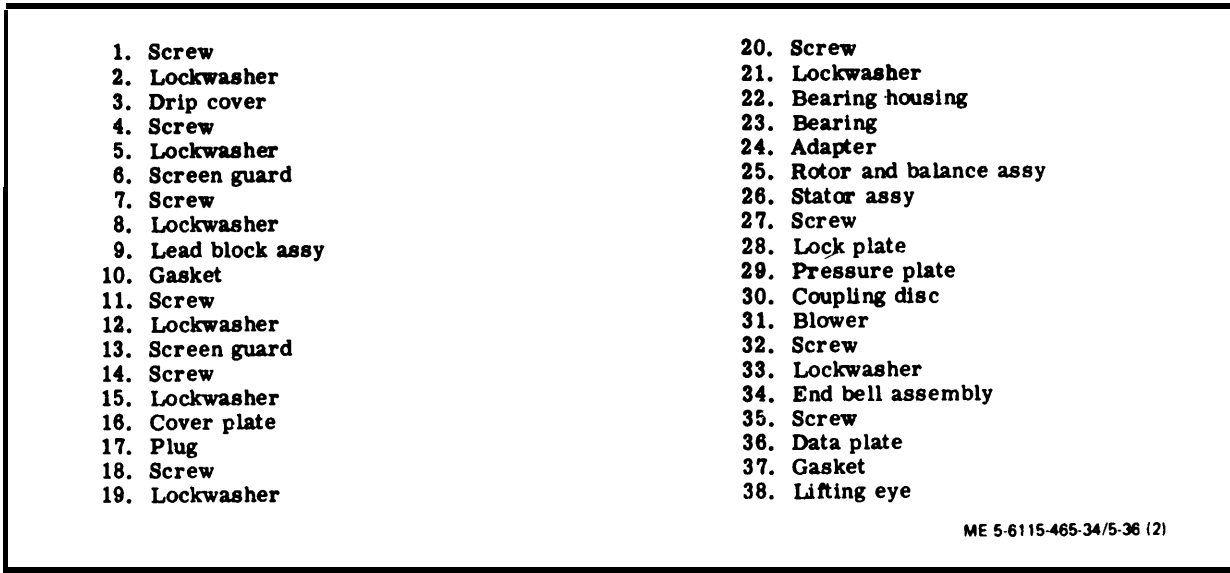

Figure 5-36. Generator Assembly, Exploded View (Sheet 2 of 2)

(9) Thread five turns of screw (18) into rotor shaft and, using a suitable puller, remove bearing (23).

(10) Support bearing on the head of a suitable press and press out adapter (24).

(11) Remove the lifting eye bolt from the generator stator.

(12) Cut a sufficient length of 1/2 inch bar stock steel to fit across the diameter of the coupling disc end of the generator assembly.

(13) Center punch and drill a 1-inch hole through the center of the bar stock.

(14) Secure the bar stock to the rotor assembly using the generator lifting eye (see figure 5-37).

(15) Locate and center punch a hole at each end of the bar stock in line with the generator housing mounting holes.

(16) Remove the generator lifting eye and the steel bar.

(17) Drill a 5/8 inch hole at each center punched position.

(18) Secure the steel bar to the stator (generator housing) with two of the screws used to secure the generator to the engine flywheel housing.

(19) Install the generator lifting eye bolt.

(20) Using a suitable lifting device, lift the generator by the eye bolt and stand it on its end bell

**NOTE**

Use block as necessary to hold the generator in the upright position.

(21) Remove the two screws securing the steel bar to the stator.

**CAUTION**

Use extreme care when lifting rotor and balance assembly from the stator assembly.

(22) Using a suitable lifting device, remove rotor and balance assembly (25, figure 5-36) from stator assembly (26) and position on a support.

(23) Remove lifting eye bolt and steel bar.

**NOTE**

If the alternator assembly is to be sent to a higher level, the rotor assembly must be secured in the stator assembly to prevent damage while in transit. The bar stock steel illustrated in figure 5-37 can be used for this purpose.

**NOTE**

**If a steel bar is not available, carefully stand generator on end and remove rotor.**

(24) Remove screw (27) to remove plate (28), pressure plate (29), coupling disc (30), blower wheel (31) from rotor and balance assembly (25).

(25) Remove screws (32) and lockwashers (33) to remove end bell assembly (34) from stator (26).

**NOTE**

Feed leads to stator through end bell as it is removed.

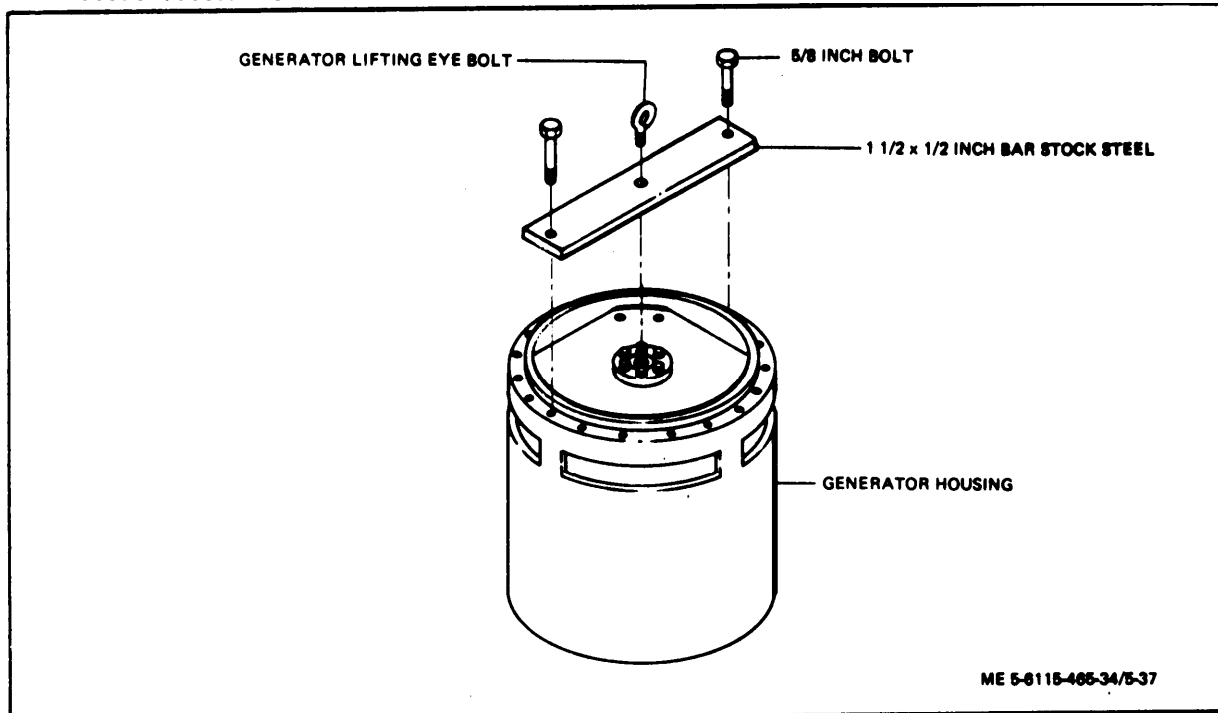

Figure 5-37. Securing Generator Rotor to Stator

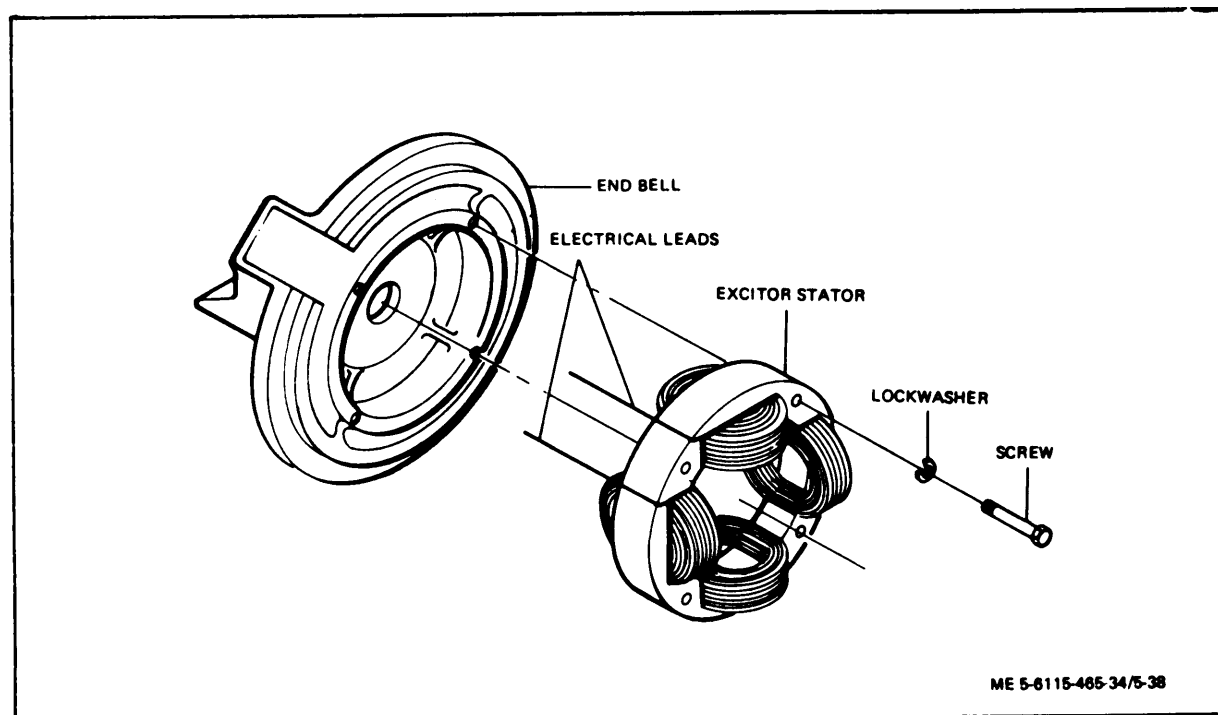

Figure 5-38. End Bell Assembly, Exploded View



(26) Do not remove screws (35) or data plate (36) unless damage is present.

(27) Remove gasket (37),

(28) If inspection reveals damage to end bell assembly, remove screws and lockwasher to remove exciter stator from end bell (figure 5-38).

(29) If inspection reveals damage to rotor and balance assembly, disassemble as follows:

**NOTE**

Disassembly of the 400 Hz and the 50/60 Hz generator rotor and balance assembly are identical as shown in figure 5-39, even though only the 50/60 Hz rotor is shown

(a) Remove screws (1, figure 5-39) and lockwashers (2) to disconnect electrical leads (3) and lug (4).

(b) Remove screws (5), flat washers (6) and cable clamps (7).

(c) Remove screws (8) and balance weights (9).

**NOTE**

Balance weights are tach welded in position. Use a chisel to break them loose.

(d) Remove screws (10) and lockwashers (11) to remove exciter rotor (12).

(e) Do not remove diodes (13) unless inspection reveals damage.

(f) Remove screws (14) and balance weights (15).

**NOTE**

Balance weights are tach welded in position. Use a chisel to break them loose.

(g) Place rotor assembly in an oven and bake at 356 F (180°C) for 3.0 to 3.5 hours.

**WARNING**

Wear asbestos gloves when handling heated rotor assembly.

**CAUTION**

Do not allow press to exert pressure on rotor core winding as damage may result.

(h) Remove rotor assembly from oven and press shaft (16) and key (17) from rotor core (18).

(30) If inspection reveals damage to the lead block assembly, disassemble as follows:

(a) Remove nuts (1, figure 5-40), lock washers (2) and screws (3).

(b) Separate pressure plates (4) and blocks (5, 6, and 7).

(31) If inspection reveals damage to stator assembly, disassemble as follows:

(a) Remove screws (1, figure 5-41) and washers (2) to remove ring (3). (400 Hz generator sets only.)

(b) Remove screws (4) and lockwashers (5) to remove lead bushing (6).

(c) Unscrew eye bolt (7) from frame assembly (8).

**NOTE**

Do not attempt to disassemble frame assembly.

c. Cleaning, Inspection, and Repair.

**WARNING**

Use solvent in a well ventilated area. Avoid inhaling solvent fumes. Do not allow solvent to come into contact with the skin.

(1) Clean all generator parts using an approved solvent. Do not dip parts into solvent.

(2) Ultra sonic cleaning may be used if available. Consult manufacturer's recommendations for cleaning solutions and procedure to be used.

(3) After cleaning, dry rotor and balance assembly, stator assembly and exciter stator by baking in an oven at 200°F (93°C) for approximately 3 hours. After drying, apply a light coating of oil (Military Specification MIL-I-9870) or corrosion preventive compound (Military Specification MIL-C-4339) to all ferrous-metal surfaces to prevent rusting.

(4) Dry all other parts with a clean, lint-free cloth.

(5) Inspect all electrical leads for a damaged or deteriorated insulation and evidence of shorting. Check each electrical lead for continuity.

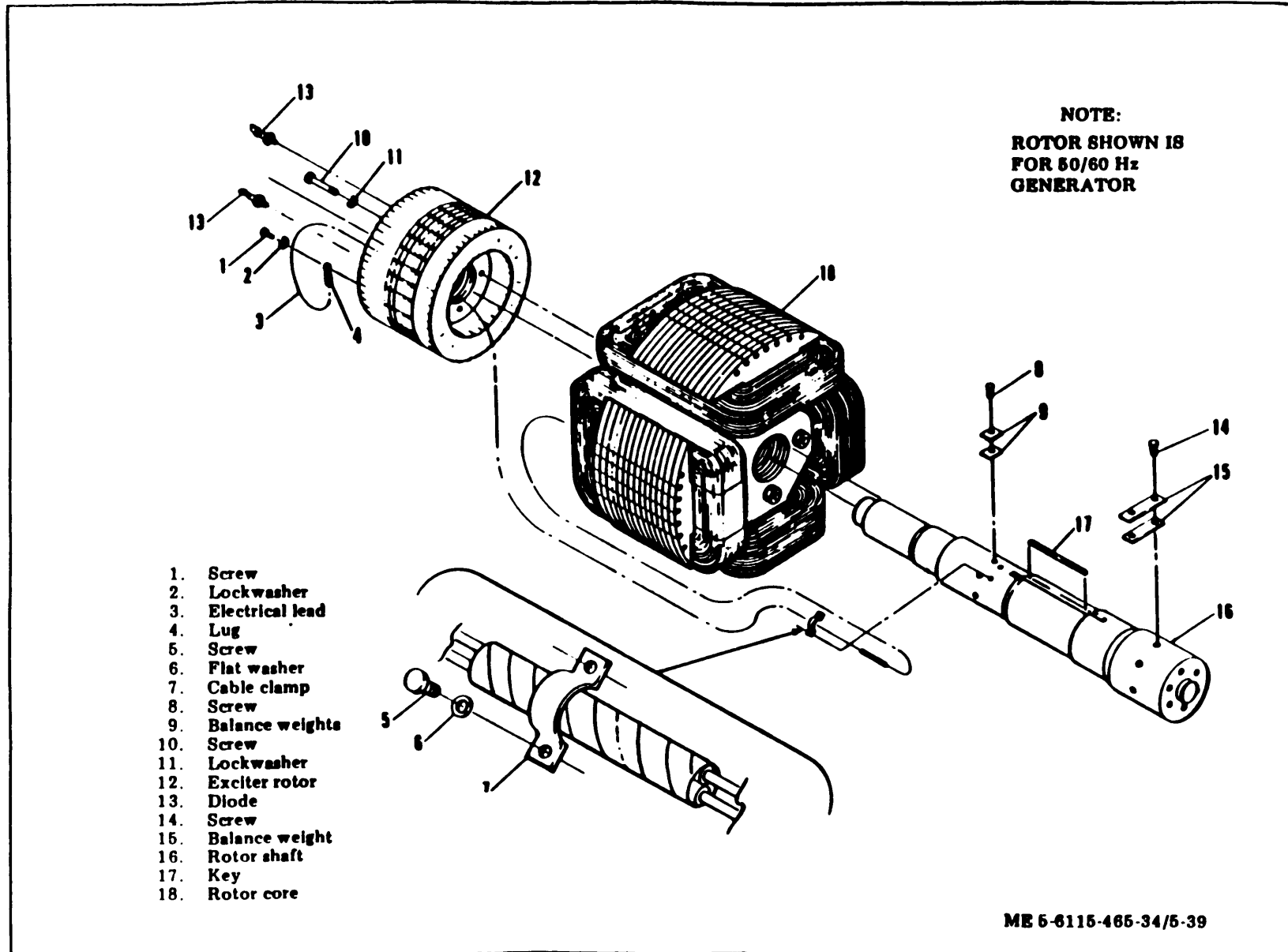

Figure 5-39. Generator Rotor and Balance Assembly, Exploded View (sheet 1)

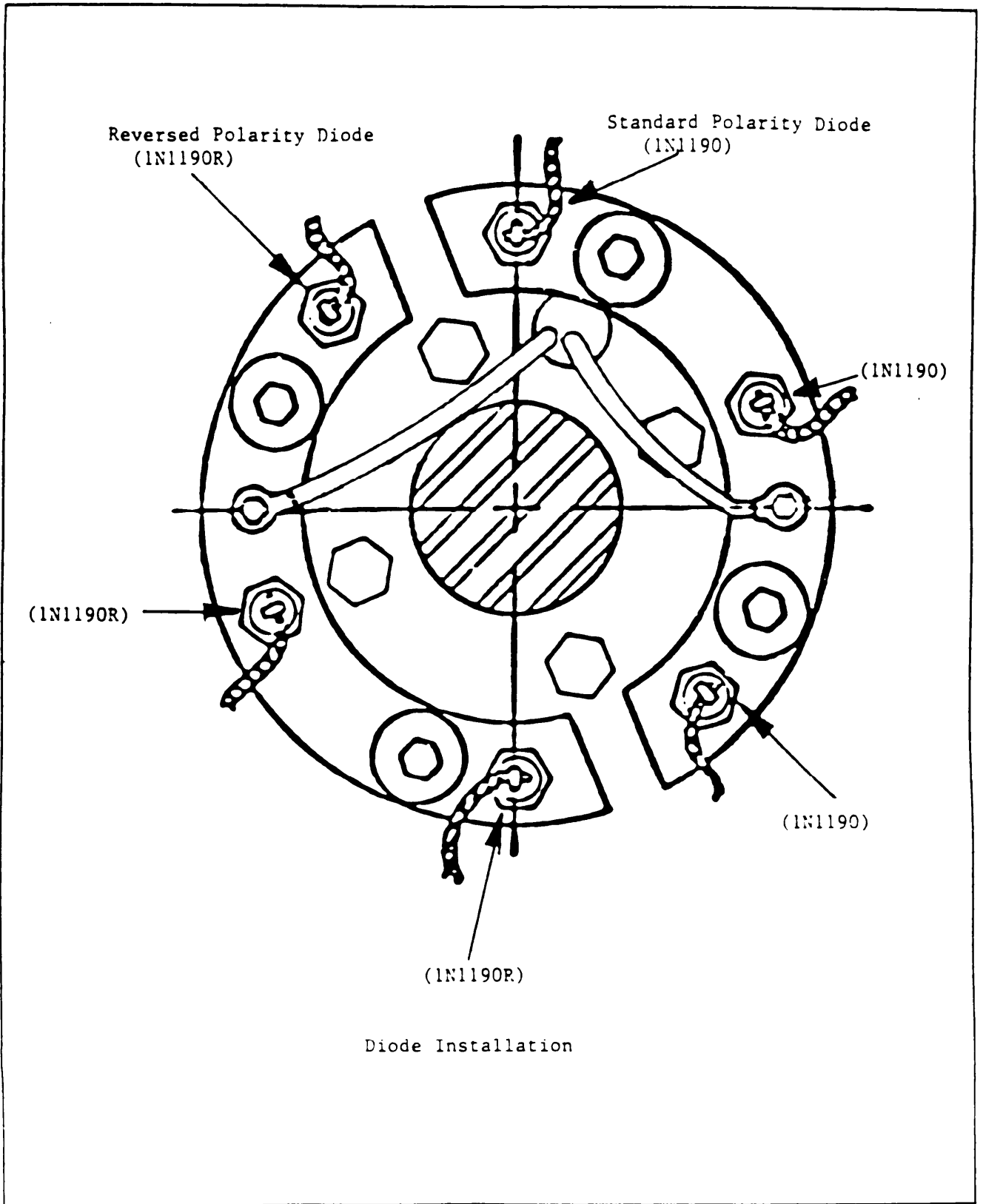

Figure 5-39. Generator Rotor and Balance Assembly, Exploded View (sheet 2)



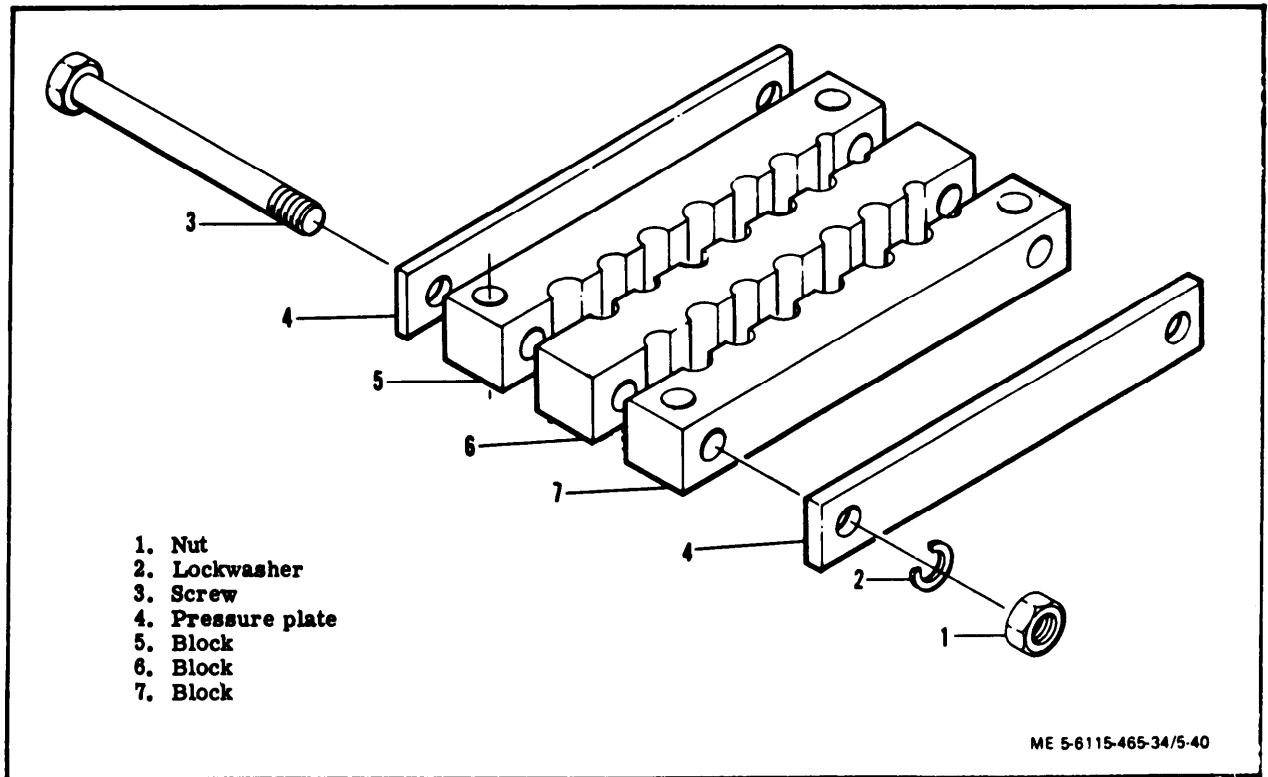

Figure 5-40. Lead Block Assembly, Exploded View

(6) Inspect blower and coupling disc for wear, cracks, breaks, or other damage.

(7) Inspect bearing kit for cracked or damaged housing. Check bearing for wear, pitting, and corrosion. Check bearing adapter for wear and corrosion.

(8) Measure inside diameter of bearing housing. Diameter shall be 3.19492 to 3.19502 inches.

(9) Measure outer diameter of bearing adapter. Diameter shall be 1.3780 to 1.3784 inches.

(10) Inspect rotor shaft for discoloration or other evidence of overheating. If it is suspected that rotor shaft is weakened, disassemble rotor assembly (paragraph b. (19) above) and perform magnetic particle inspection in accordance with Military Specification MIL-I-6868.

(11) Inspect rotor and exalter cores for evidence of shorting and overheating. Check windings for physical damage.

(12) Inspect rectifiers for evidence of shorting and overheating.

(13) Inspect end bell assembly for cracks, corrosion, and other damage. Inspect exalter stator

for evidence of shorting and overheating. Check windings for physical damage.

(14) Inspect lead block assembly for cracks, corrosion, and other damage.

(15) Inspect stator assembly for cracks, corrosion, and other damage. Check windings for evidence of shorting or other physical damage.

#### WARNING

When making electrical checks, take precautions to avoid accidental contact with conductors carrying high voltage. Make certain that test leads are properly connected.

#### CAUTION

Make sure that component being tested is electrically isolated from all other components.

(16) Using tester, ground check rotor core by applying 300 Vac at 60 Hz RMS for 1 second between heat sink and rotor shaft. There shall be no evidence of dielectric breakdown.

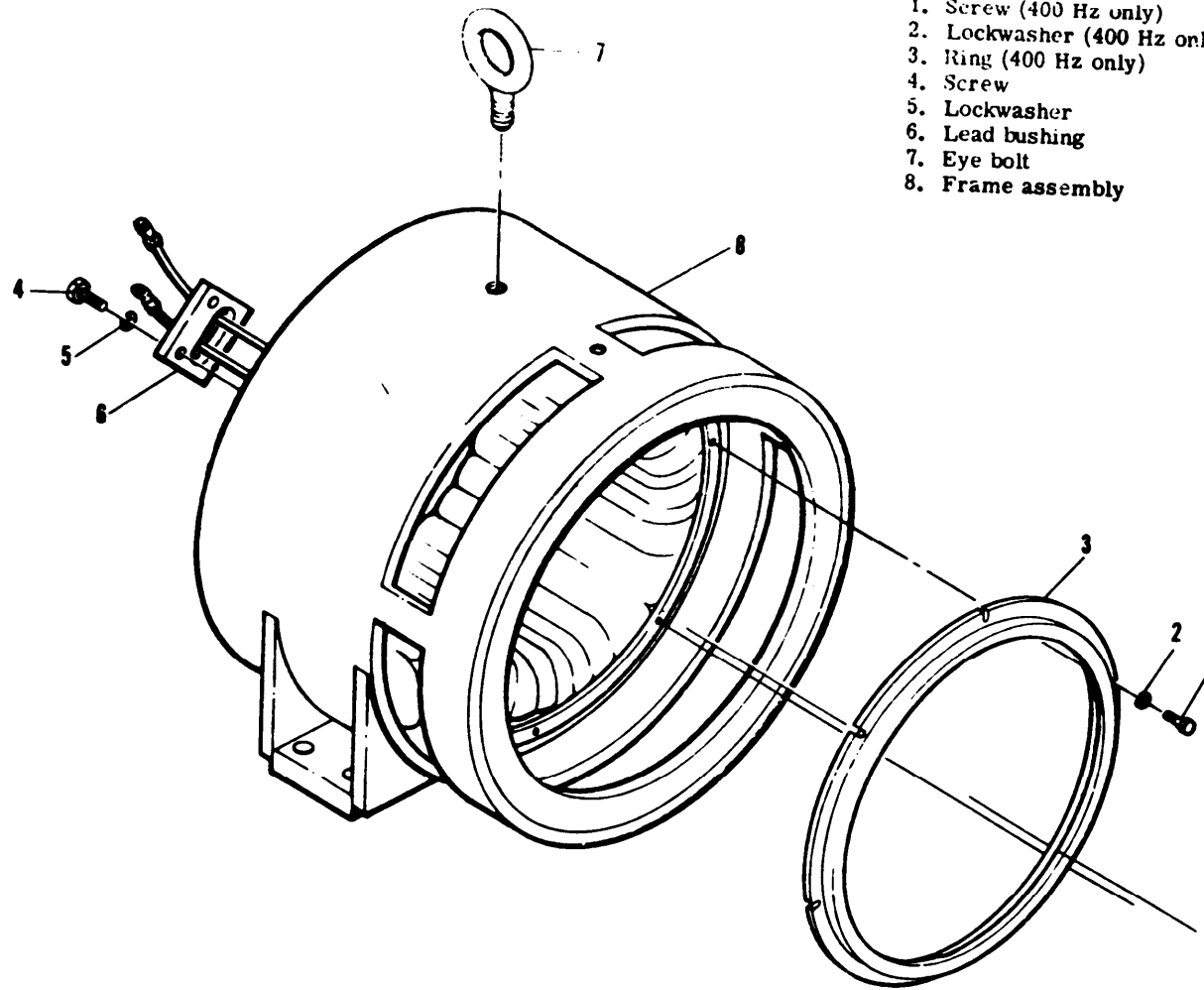

- 1. Screw (400 Hz only)
- 2. Lockwasher (400 Hz only)
- 3. Ring (400 Hz only)
- 4. Screw
- 5. Lockwasher
- 6. Lead bushing
- 7. Eye bolt
- 8. Frame assembly

TM 5-6115-465-34  
TO 35C2-3-446-2  
NAVFAC P-8-625-34  
T.M. 06858B/06859D-34

ME 5-6115-465-34/5-41

Figure 5-41. Generator Stator Assembly, Exploded View

(17) Using a double bridge, measure resistance of rotor core. Resistance shall be 0.2154 to 0.2486 ohms at 77°F (25°C).

(18) Install rotor and balance assembly on a dymetric balance machine and check for static and dynamic balance. Unbalance shall not exceed 0.5 inch-ounce in either balance plane. Balance rotor and balance assembly as outlined in step (25) below.

(19) Install blower and coupling disc assembly on a dymetric balance machine and check both static and dynamic balance. Unbalance shall not exceed 0.5 inch-ounce in either plane. Balance blower and coupling disc assembly as outlined in step (26) below.

(20) Use a double bridge to measure resistance of each phase of exciter rotor. Resistance of each phase shall be 0.1473 to 0.1627 ohm at 770 F (25°C). Difference between phase reading shall not exceed 2 percent.

(21) Using 374 megger, ground test exciter by applying 300 Vac at 60 Hz RMS for 1 second between one terminal and ground (frame). There shall be no evidence of dielectric breakdown.

(22) Using a double bridge, measure resistance between terminals of exciter stator. Resistance shall be 4.50 to 5.50 ohms at 77°F (25°C).

(23) Using 374 megger tester, ground test stator assembly by applying 750 Vac at 60 Hz RMS for one second between all leads (tied together) and the frame. Apply 500 Vac at 60 Hz RMS for one second between phases with neutral open. There shall be no indication of dielectric breakdown in either test.

(24) Use semiconductor test set to test rectifiers for inverse current leakage at peak recurrent voltage of 600 volts leakage shall not exceed 20.0 milliamperes at 77°F (25°C). Check forward voltage drop. Voltage drop shall not exceed 1.2 volts at 77°F (25°C).

(25) If rotor and balance assembly is out of balance, add or subtract balance weights until remaining unbalance in both balance planes does not exceed 0.5 ounce-inch. Once rotor and balance assembly is balanced, each weld balance weights and attaching screw.

(26) If blower and coupling disc assembly is out of balance, correct by machining material from inner diameter of blower as required. Remaining unbalance shall not exceed 0.5 inch-ounce in both balance plans.

(27) If damage to the stator windings is discovered during inspection and test, rewind using figure 5-42 (figure 5-43 for 400 Hz) as a guide.

(28) After rewinding, vacuum impregnate the stator assembly as follows:

(a) Place wound stator in an oven at 300° F (-0, +15° F (149 C) for 120 ± 10 minutes.

(b) Transfer stator to vacuum tank.

#### NOTE

Do not allow temperature of stator to drop below 125 F.

(c) Evacuate tank to a maximum of 50 mm Hg absolute and hold for 10 minutes (minimum).

(d) Without breaking the vacuum, introduce varnish (Military Specification MIL-I-24092, Type M, Class 155) to a sufficient depth to completely cover the stator. Hold vacuum for 5 minutes (minimum).

(e) Break vacuum and hold at atmospheric pressure for 5 minutes (minimum).

(f) Return varnish to storage tank and allow the stator to drain.

(g) Place the impregnated stator in an oven at 300 F, -0 F, +15°F, (149°C) for 120 ± 10 minutes.

(29) If damage to rotor core windings is discovered at inspection and test, rewind in accordance with figure 5-44 (figure 5-45 for 400 Hz).

(30) Impregnate the wound rotor as follows:

(a) Mark all fit surfaces to prevent the resin from adhering.

(b) Preheat the wound core for 2 hours (minimum) at 302°F (150°C) (minimum).

(c) Allow the core to cool in ambient surroundings to 104°F (40°C) (maximum).

(d) Place the core in the vacuum tank and evacuate to 1 to 5 mm Hg and hold for 15 minutes.

(e) Without breaking the vacuum, admit the resin into the tank to a sufficient depth to cover the core. Hold the vacuum for a minimum of 5 minutes.

(f) Break the vacuum and pressurize the tank to 85 to 90 psig. Hold for a minimum of 30 minutes.

(g) Reduce the pressure to zero, then increase as necessary to remove the resin from the tank.

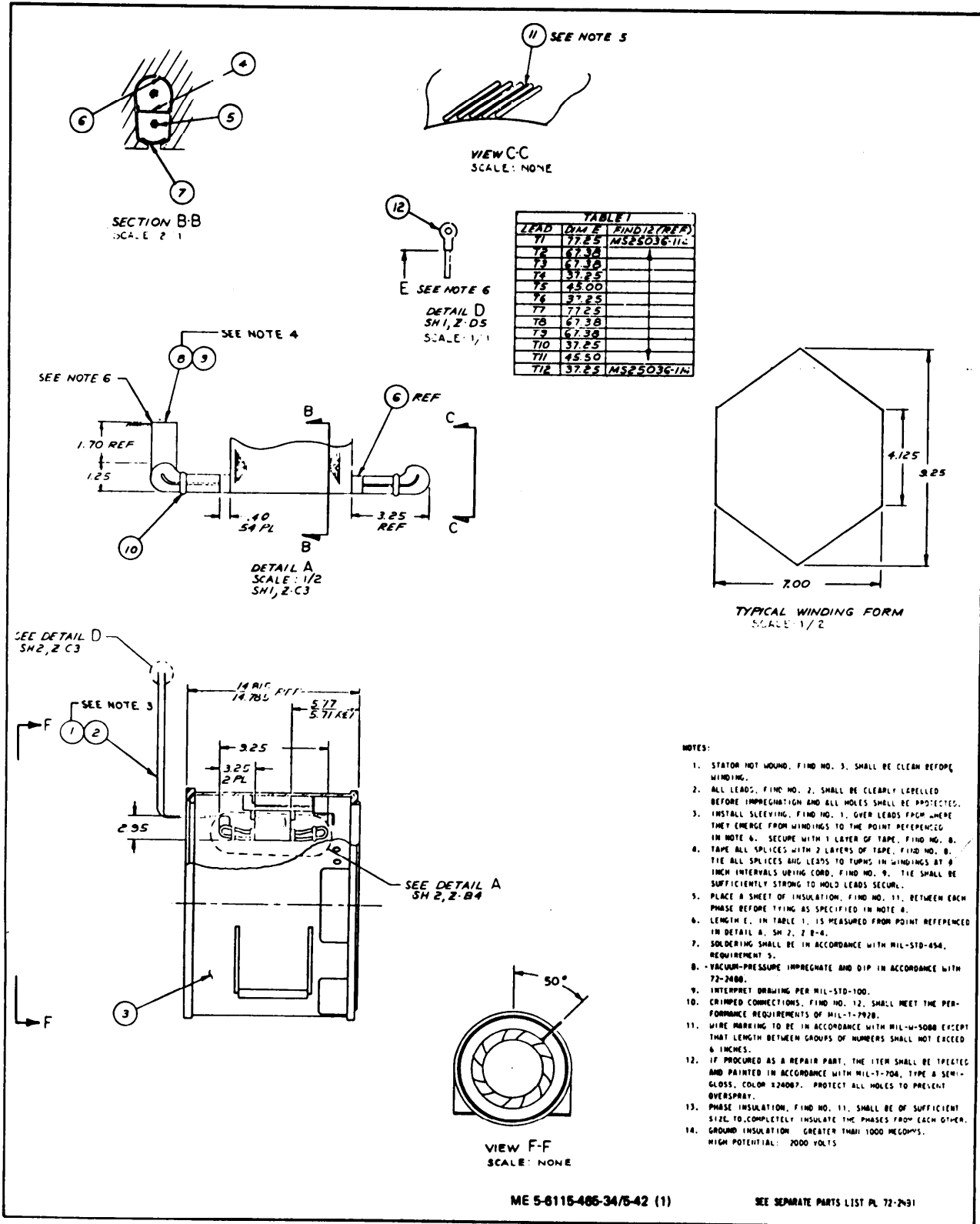
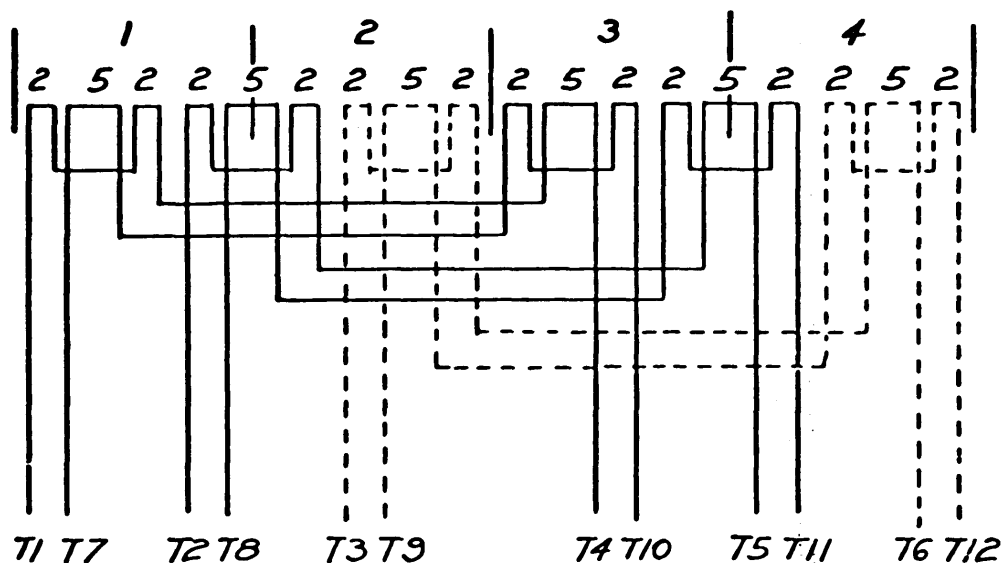

Figure 5-42. 50/60 Hz Generator Stator Winding Procedures (Sheet 1 of 2)



1. Insulation, sleeving
2. Wire
3. Stator assy (not wound)
4. Liner, slot
5. Wire
6. Separator
7. Liner, slot end
8. Insulation tape
9. Cord
10. Insulation tape
11. Insulation, tape
12. Terminal lug



CONNECTION DIAGRAM

WINDING DATA	
TYPE OF WINDING	3 PHASE
NO OF SLOTS AND COILS	54
NO OF COILS PER GROUP	12 GROUPS OF 2 ; 6 GROUPS OF 5
TURNS PER COIL	7
CONDUCTOR	3 OF NO 16, RND
CONNECTION	SEE CONNECTION DIAGRAM
SPACING	1-12

ME 5-6115-465-34/5-42 (2)

TM 5-6115-465-34  
 TO 35C2-3-446-2  
 NAVFAC P-8-625-34  
 TM 06858B/06859D-34

Figure 5-42. 50/60 Hz Generator Stator Winding Procedures (Sheet 2 of 2).

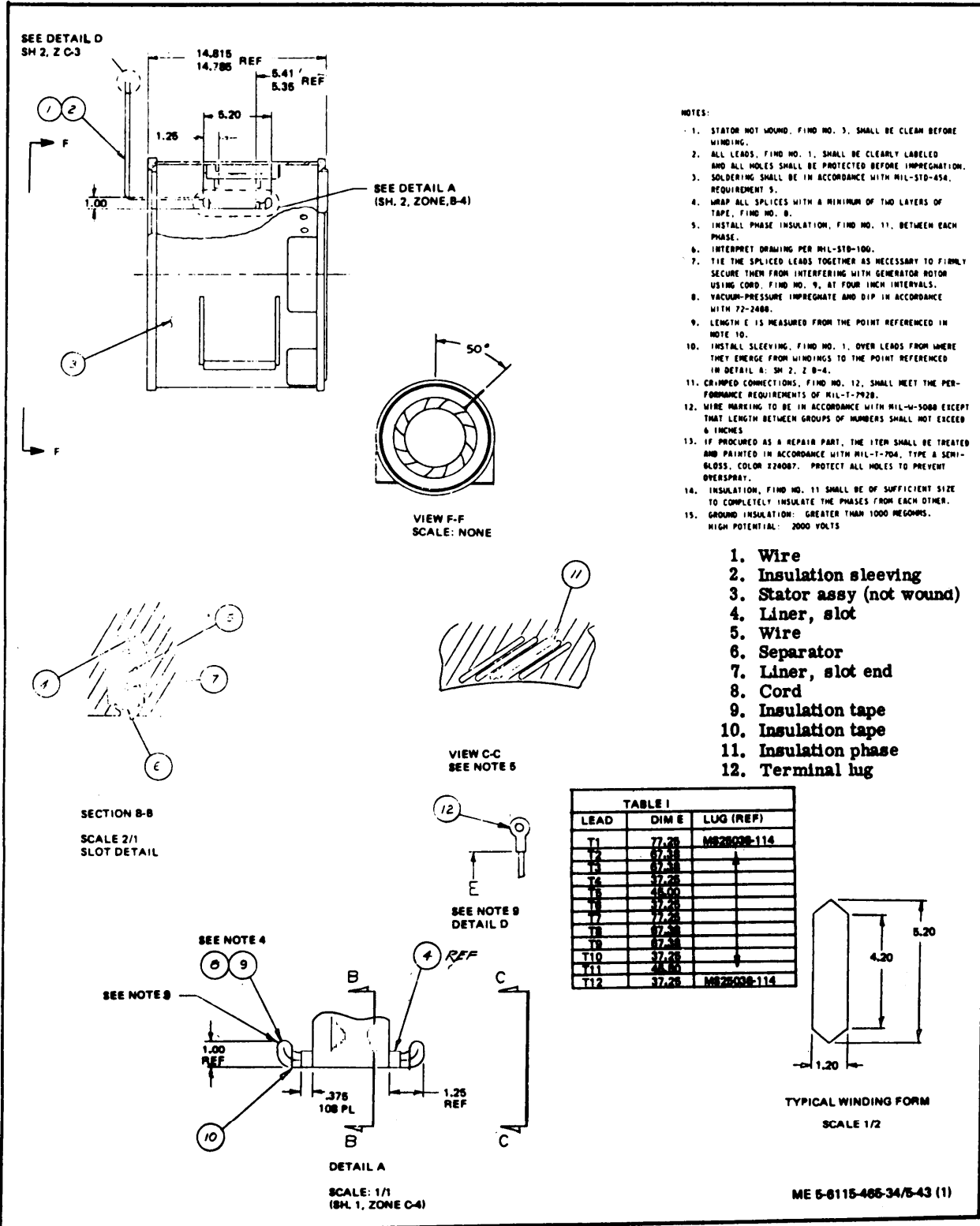
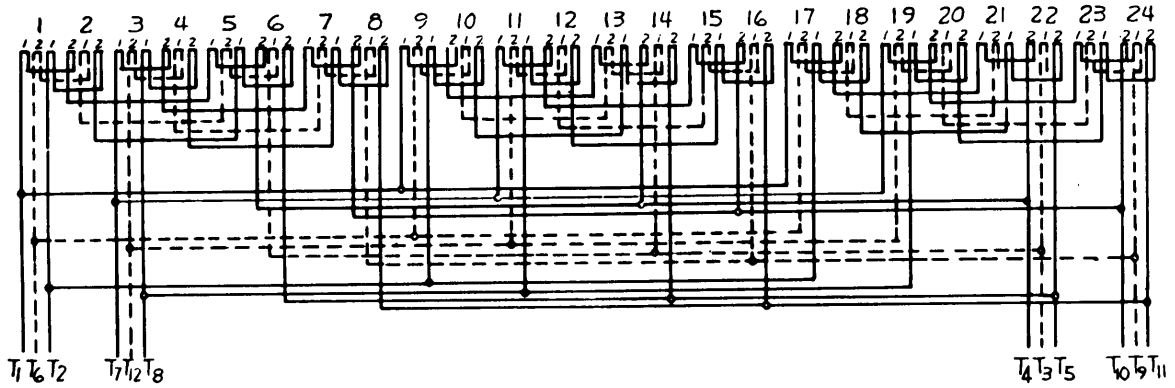

Figure 5-43. 400 Hz Generator Stator Winding Procedures (sheet 1 of 2)



CONNECTION DIAGRAM

WINDING DATA	
TYPE OF WINDING	3 PHASE
NO. OF SLOTS AND COILS	108
NO. OF COILS PER GROUP	36 GROUPS OF 1 36 GROUPS OF 2
TURNS PER COIL	8
CONDUCTOR	1 OF NO. 16 RD.
SPAN	1-4
CONNECTION	SEE CONN. DIAGRAM

ME5-6115-465-34/5-43(?)

Figure 5-43. 400 Hz Generator Rater Winding Procedures (Sheet 2 of 2)

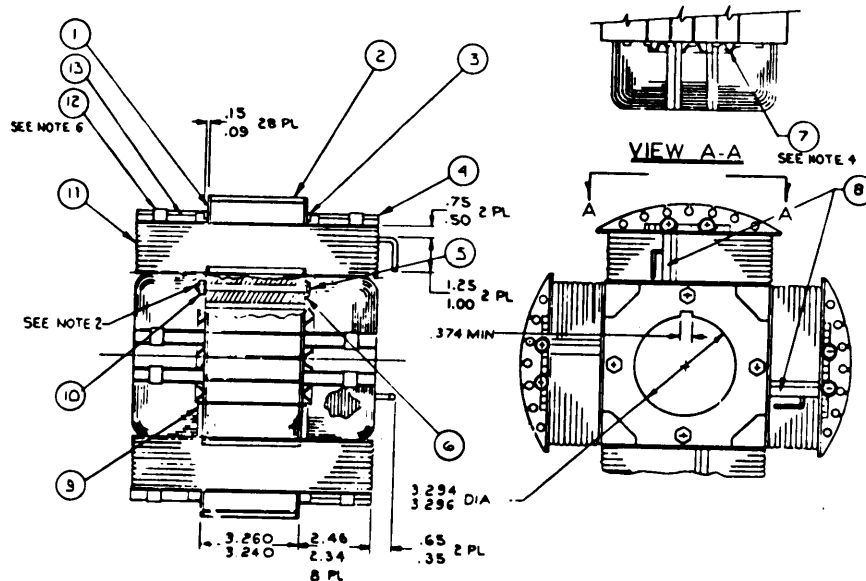

1. Lamination, core
2. Lamination, core
3. Rod, cage
4. Rod, retainer
5. Screw, cap
6. Washer, lock
7. Spacer, coil
8. Tape, glass
9. Insulation
10. Locknut
11. Wire
12. Tape, glass
13. Slot, liner

1. INTERPRET DRAWING PER MIL.-STD-100.
2. STACK LAMINATIONS, FIND NOS. 1 AND 2, ON I.D. UNDER 2.5 + 10% TONS.
3. BRAZE CAGE ROD, FIND NO. 3, TO LAMINATIONS, FIND NO. 1, IN ACCORDANCE WITH MIL-B-7883. TYPE I, GRADE B. BRAZING FLUX SHALL BE IN ACCORDANCE WITH AWS TYPE 3A.
4. ONE COIL SPACER SHALL BE USED AT EACH OF EIGHT PLACES.
5. APPLY 4 LAYERS OF TAPE, FIND NO. 8, TO SECURE CABLE STUDS.
6. APPLY 2½ LAYERS OF TAPE, FIND NO. 12, TO SECURE INSULATION, FIND NO. 12, TO ROD, FIND NO. 4.
7. VACUUM-PRESSURE IMPREGNATE IN ACCORDANCE WITH 72-2487.
8. CLEAN CABLE STUDS AFTER IMPREGNATION.
9. TORQUE CAP SCREWS, FIND NO. 5, TO 17 FT-LB ± 10% WHILE THE LAMINATIONS ARE UNDER PRESSURE.
10. GROUND INSULATION: GREATER THAN 200 MEGOHMS.  
HIGH POTENTIAL: 1500 VOLTS.

ME5-6115-465-34/5-44

Figure 5-44. 50/60 Hz Generator, Rewind Procedures

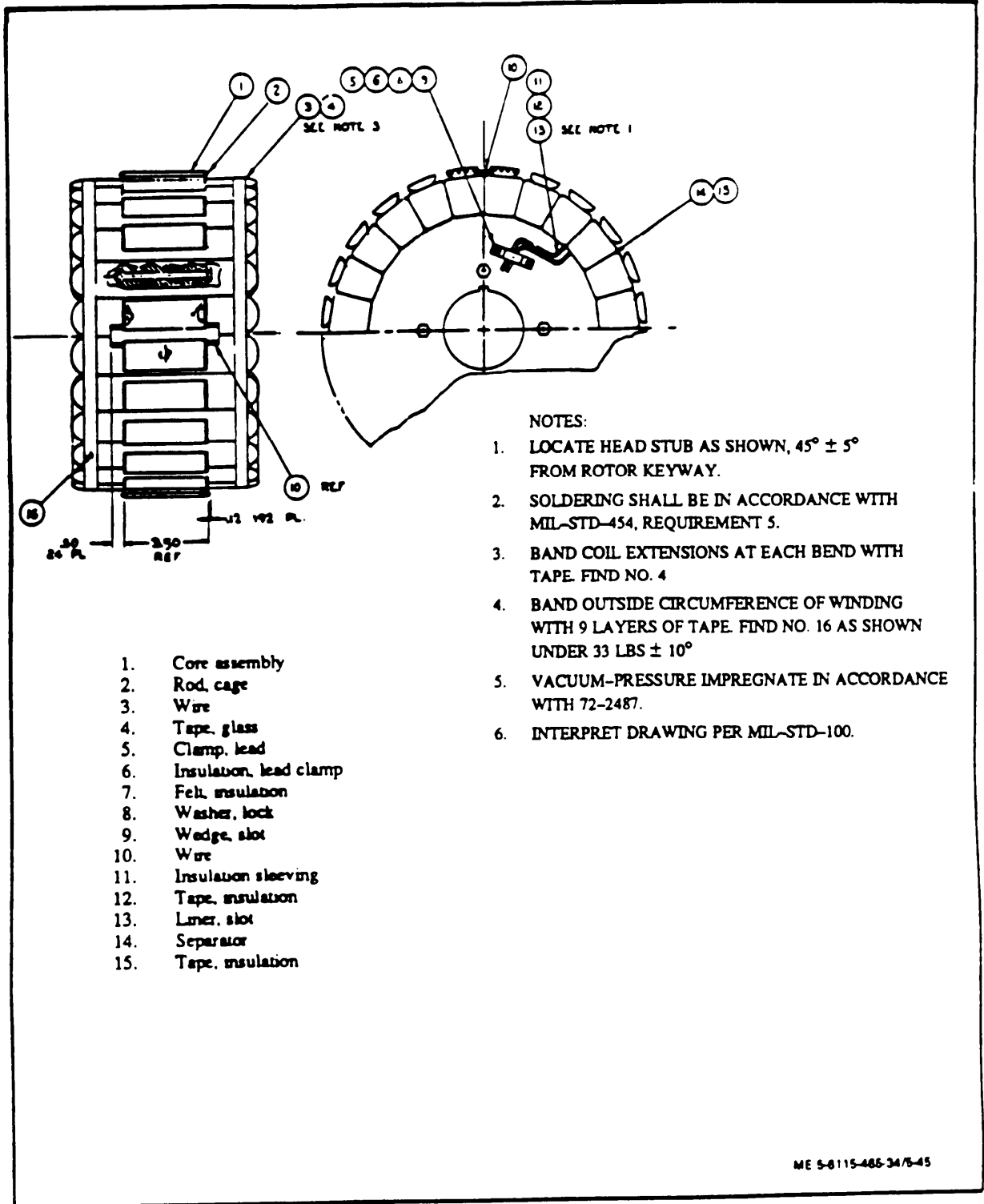

Figure 5-45. 400 Hz Generator Rotor Winding Procedures

(h) Drain the core for a minimum of 30 minutes.

(i) Place the core in an oven and heat to a temperature of 302°F (150°C). Cure at this temperature for a minimum of 16 hours.

(31) If damage to the exciter stator is discovered at inspection and test, rewind in accordance with figure 5-46.

(32) Vacuum impregnate bobbins in accordance with step (28) above prior to installing on lamination.

(33) If damage to the exciter rotor is noted at inspection and test, rewind in accordance with figure 5-47.

(34) After winding the rotor, vacuum pressure impregnate as directed in step (30) above.

(35) Replace all worn or damaged parts and parts which fail to meet inspection requirements.

#### d. Assembly.

(1) Assemble stator assembly as follows:

(a) Screw eye bolt (4, figure 5-41) into frame assembly (5).

(b) Install lead bushing (3) and secure with lockwasher (2) and screws (1). Torque screws to 17 lbs-ft.

(2) Assembly lead block assembly as follows:

(a) Assemble blocks (6 and 6, figure 5-40) and pressure plates (4).

(b) Install with screws (3), lockwashers (2) and nuts (1). Do not tighten.

(3) Assemble rotor and balance assembly as follows:

(a) Heat rotor core (18, figure 5-39) in an oven for 3.0 to 3.5 hours at 356.0°F (180.0°C).

(b) Install key (17) into slot of rotor shaft (16).

#### WARNING

Wear asbestor gloves when handling heated rotor. Serious burns may result from failure to observe this warning.

#### CAUTION

Do not use press which contacts core windings. Press only on core laminations.

(c) Remove heated rotor core from oven and press onto rotor shaft until firmly seated against shoulder. Do not allow key to project more than 0.12 inch on either side of rotor.

(d) Insure exciter rotor is positioned so that lead holes are equal distance on each side of lead slot in rotor shaft.

(e) Feed field leads from generator field (18) through exciter rotor (12).

(f) Mount exciter rotor (12) onto rotor shaft and secure with lockwasher (11) and screws (10). Torque screws to 60 pounds-inch.

#### **NOTE**

Remove only one diode at a time  
(Figure 5-39 sheet 2)

(g) Install rectifies (13) and torque to 28 pounds-inch. Connect leads to rectifiers and solder in accordance with established procedures.

(h) Install cable clamps (7), lockwashers (6), and screws (5).

(i) Connect electrical leads (3) and secure with lockwashers (2) and screws (1).

(j) Install lug (4) on electrical lead (3).

(k) Temporarily install balance weights (15 and 9) and screws (14 and 8).

(l) Balance rotor and balance assembly (paragraph c.(25) above).

(m) Remove screws, lockwashers, and weigh.

(n) Coat screws with Loctite, Grade C (no known government specification) and allow to dry.

(o) Install balance weights, lockwashers, and screws. Torque screws to 31 lb-ft.

(p) Tach weld screws and single hole weights to prevent movement.

(q) Install blower wheel (31, figure 5-36); coupling disc (30), pressure plate (29), lock plate (28) with screws (27).

(r) Torque screw to 75 lbs-ft, and bend lock tab of lock plate (28) against flat of screw.

(s) Using 5/8 in. bolts and nub, temporarily fasten coupling disc to blower.

(4) Assemble end bell assembly as follows:

(a) Assemble exciter stator (figure 5-38) to end bell. Insuring electrical leads are lined with lead opening.

(b) Secure with lockwashers and screws.

(5) Assembly generator assembly as follows.

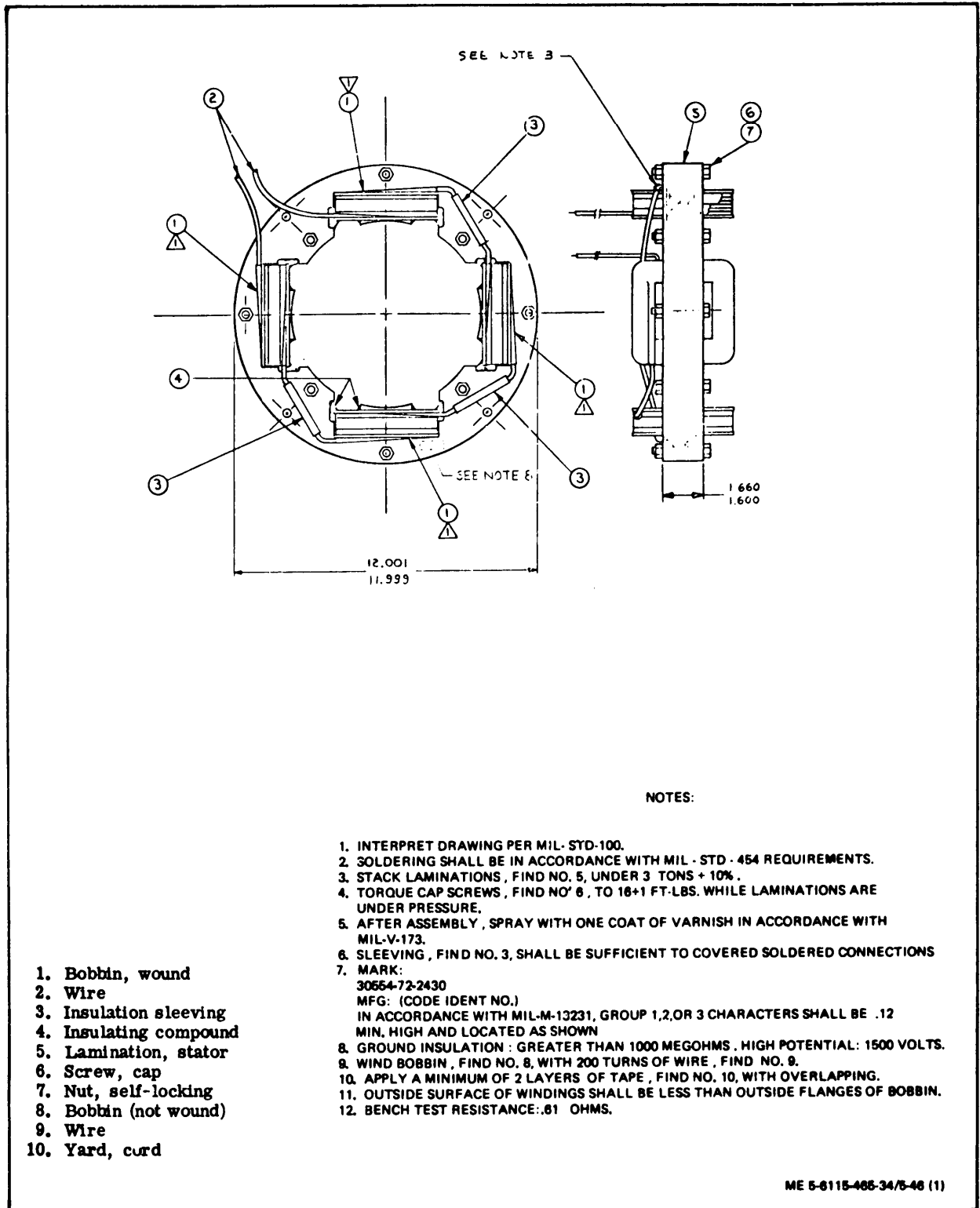
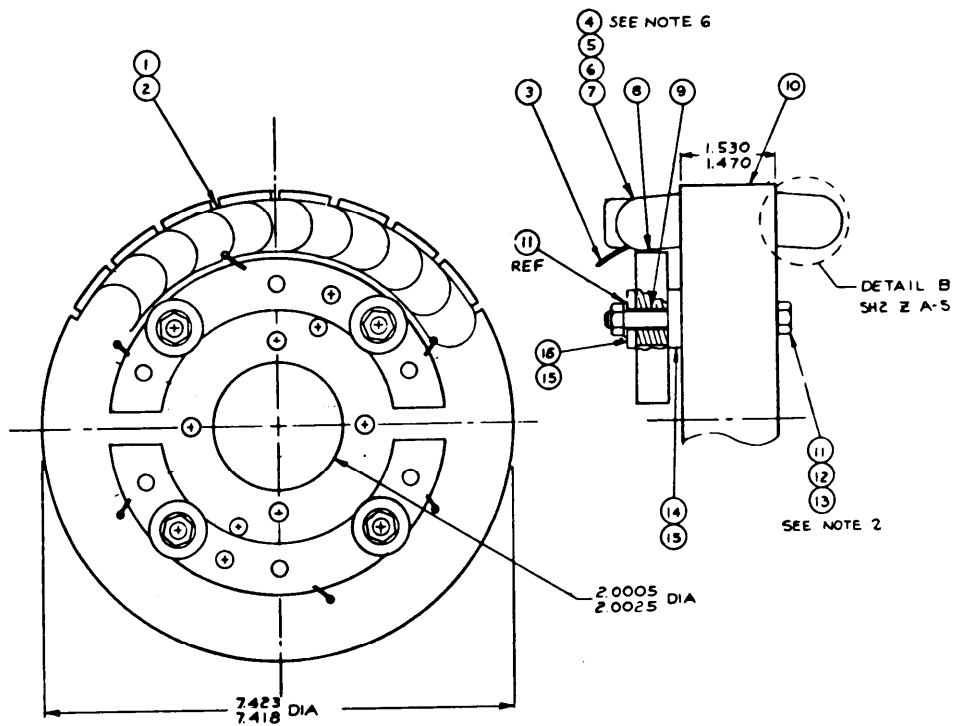

Figure 5-46. Generator Exalter Stator Winding Procedures  
 (Sheet 1 of 2)







NOTES:

1. Liner, slot
2. Separator
3. Wire
4. Sleeving
5. Wire
6. Tape, glass
7. Cord
8. Heat sink
9. Insulator, bushing
10. Lamination
11. Screw, cap
12. Washer, flat
13. Nut, self-locking
14. Washer, insulating
15. Thermopoxy compound
16. Washer, insulating

1. STACK LAMINATIONS, FIND NO. 9, ON I.D. UNDER 2+10% TONS.
2. TORQUE CAP SCREWS, FIND NO. 11, TO 60 INCH LBS MAX., WHILE CORE IS UNDER PRESSURE.
3. SOLDER LEADS, FIND NO. 3, TO WINDINGS, FIND NO. 5, AND TAPE CONNECTIONS WITH FIND NO. 6. . INSTALL SLEEVING 4, OVER LEADS, AND TIE LEAD TO NEAREST TURN IN WINDING USING CORD 7, TIE SHALL BE SUFFICIENTLY STRONG TO SECURE LEAD.
4. INTERPRET DRAWING PER MIL-STD-100.
5. SOLDERING SHALL BE IN ACCORDANCE WITH MIL-STD-454, REQUIREMENT 5.
6. AFTER WINDING STACKED AND BOLTED LAMINATIONS, FIND NO.9, VACUUM PRESSURE IMPREGNATE. PROTECT ALL HOLES DURING TREATMENT.
7. GROUND INSULATION GREATER THAN 200 MEGOHMS .. HIGH POTENTIAL : 1500 VOLTS.

ME 5-6115-465-34/5-47 (1)

Figure 5-47. Generator Exciter Rotor Winding Procedures (Sheet 1 of 2)

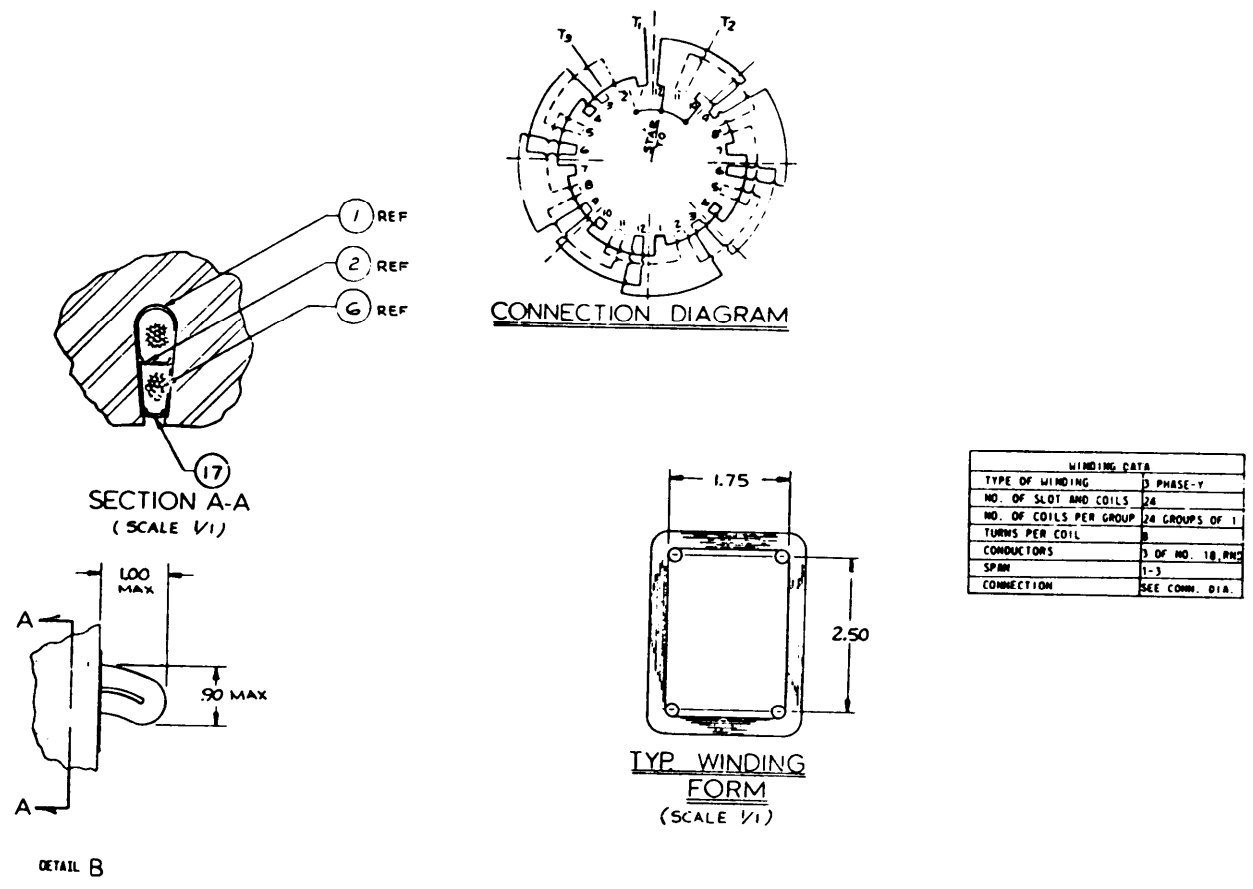

ME 5-6115-465-34/5-47 (2)

Figure 5-47. Generator Exciter Rotor Winding Procedures (Sheet 2 of 2)

(a) Secure end bell assembly (34, figure 5-36) to stator (26) using lockwashers (33) and screws (32). Torque screws to 31 ft-lb.

(b) Feed electrical leads through gasket (10) and insert them through loosely assembled lead block (9).

(c) Pull all slack from the leads and tighten the clamping screws of lead block.

(d) Secure lead block and gasket to end bell assembly using lockwashers (8) and screws (7).

(e) Using a suitable lifting device stand the stator assembly on the end bell.

#### NOTE

Use blocking as necessary to maintain stator in the vertical position.

(f) Remove the lifting eye bolt from the stator and install it in the coupling disc end of the rotor shaft.

#### CAUTION

Use extreme care when installing rotor to avoid damage to the generator windings.

(g) Using a suitable lifting device, install the rotor (25) into the stator (26).

(h) Temporarily secure rotor to stator as in disassembly (see figure 5-37).

(i) Carefully set the stator on its mounting feet.

(j) Press new bearing (23) onto adapter (24).

(k) Install bearing and adapter and secure with a flat washer and screw (18).

(l) Remove screw and replace flat washer with lockwasher (19). Torque screw (18) to 88 ft-lbs.

(m) Install bearing housing (22) and secure with lockwashers (21) and screws (20). Torque screws to 31 ft-lbs.

#### NOTE

Center bearing housing in end bell prior to torquing screws.

(n) Install screen guard (13) and secure with lockwashers (12) and screws (11).

(o) Install cover (16) and secure with lockwashers (15) and screws (14).

(p) Install cover (17) into bearing housing.

(q) Install screen guard (6) and secure with lockwashers (5) and screws (4).

(r) Install drip cover (3) and secure with lockwashers (2) and screws (1).

(s) Remove steel bar securing rotor to stator and install lifting eye bolt on generator stator.

e. Testing. Perform winding resistance test, high potential test, and insulation resistance test using equipment and procedures specified in Military standard MIL-STD-705.

f. Installation. Install generator assembly in reverse order of removal procedures.

5-16.1. The field flash circuit consists of the following components: The speedswitch, K5 relay (located on A5 board), current limiting resistor, exciter field windings, associated wiring.

a. Testing Stator, Exciter (On Equipment Test). Locate end disconnect the exciter stator winding resistance using an ohmmeter. On the 15 KW and 30 KW generator sets, leads (F1-F2) are located on a terminal board near the static exciter/voltage regulator control box. Check across F1 and F2 for resistance. A normal resistance reading of 1 to 4 ohms should be found. If the resistance of the exciter winding is not as specified, refer to the applicable section of the TM for replacement/repair of the exciter stator winding.

b. Equipment Test of Field Flash Circuit. Assuming the exciter stator winding resistance is correct (within 1 to 4 ohms, Pore 5-11a) connect a DC voltmeter (0 to 30 volts) to the two wires that were disconnected from the exciter stator windings. NOTE: Do not reconnect the wires to F1 and F2 at this time.

c. Remove connector (P37) from the speed switch. Place a jumper between pins A and C on P37. Momentarily (10 to 15 seconds) place the "start-stop-run" switch in the start position and observe the DC voltmeter. If the voltmeter indicates approximately 24 volts, the probable cause of the field flash failure is the speed switch. If a DC voltage is not present, proceed to the next step.

d. Remove connector (P3) from the speed switch. Place a jumper between pins A and C of socket (J3) on the special relay box. For approximately 24 volts DC. If DC voltage is not present, the problem may be the wiring between the speed switch and the special relay box, the K5 relay or current limiting resistor (R35) inside the special relay box (15 KW and 30 KW generator sets only). If a voltage is present, replace connector (P31 on socket (J3) and proceed to the next step.

e. Remove connector (P9) from the static exciter/voltage regulator control box. Momentarily hold the "start-stop-run" switch in the start position and check between pins C and D of P9 for approximately 24 volts DC. If a DC voltage

is not present, the problem may be the wiring between the special relay box and the static exciter/voltage regulator control box. If a DC voltage is present, replace connector (P9) on socket (J9) and proceed to the next step.

f. Remove connector (P13) from the static exciter/voltage regulator control box. Momentarily hold the "start-stop-run" switch in the start position and check between pins S and R of J13 on the control box for approximately 24 volts DC. If a DC voltage is not present the problem may be any one of the following items within the control box.

- (1) Broken wiring within the control box.
- (2) Current limiting resistor (R219) sets.
- (3) Current limiting resistor (R17) sets.

g. Reconnect the wires previously removed from the exciter field winding (F1-F2).

SectionV. ELECTROMAGNETIC INTERFERENCE SUPPRESSION COMPONENTS

**5-17. TESTING FOR ELECTROMAGNETIC INTERFERENCE.**

If electromagnetic interference is suspected, unit shall be tested in accordance with MIL-STD-461.

**5-18. REPLACEMENT OF INTERFERENCE SUPPRESSION COMPONENTS,**

a. Refer to the Operator and Organizational Maintenance Manual to replace fuel transfer pumps.

b. To replace capacitors at load terminal:

(1) Remove screws (1, figure 5-48) and disconnect and tag electrical leads.

(2) Remove nuts (2), screws (3), capacitors (4) and lockwashers (5) from bracket (6).

(3) Reassemble in reverse order using new capacitors.

c. Refer to figure 5-30 to replace capacitors in static exciter.

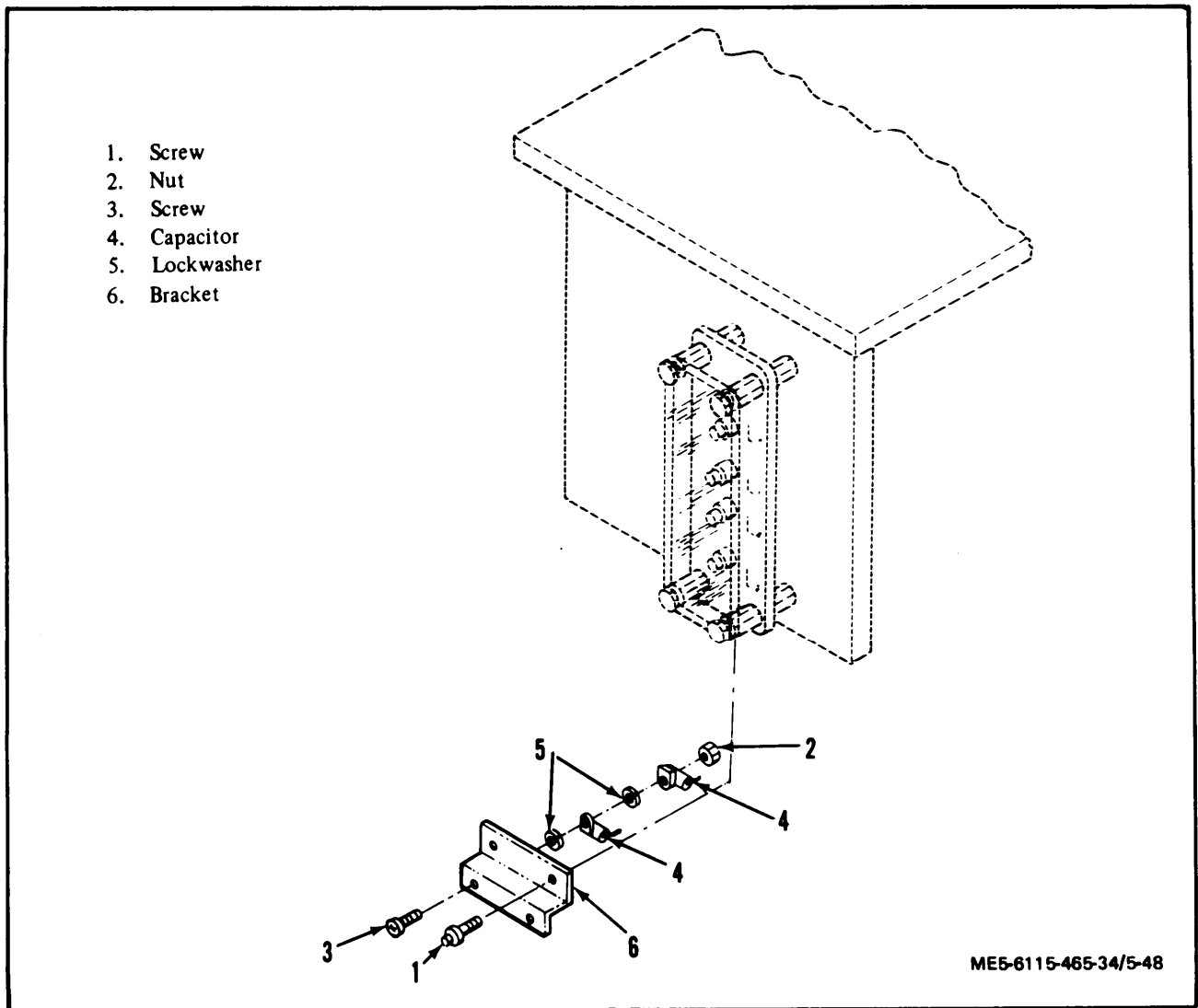

Figure 5-48. Interference Suppression Components



CHAPTER 6  
ENCLOSURE ASSEMBLY REPAIR INSTRUCTIONS

Section I. HOUSING ASSEMBLY

**6-1. GENERAL.**

The housing assembly fully encloses the top, sides, and ends of the generator set. It consists of doors, covers, panels and supports. All openings into the interior of the generator set are equipped with sealing doors which prevent the entry of foreign material when the doors are closed.

**6-2. RELAY TABLE MAINTENANCE.**

a. Removal.

(1) Refer to the Operator and Organizational Maintenance Manual and remove housing assembly doors, covers, and panels.

(2) Remove relay tables by following the ascending sequence of index numbers (1 through 36) assigned to figure 6-1.1.

**NOTE**

It is not necessary to completely disassemble the relay table to replace a single part. Only those parts requiring repair or replacement need be removed.

b. Cleaning, Inspection, and Repair.

(1) Clean relay table parts in dry cleaning solvent (Federal Specification P-D-680) and dry thoroughly.

(2) Inspect relay table for breaks, cracks, and other damage.

(3) Check all parts for defective paint.

(4) Check all threads for crossing, stripping, and peening.

(5) Repair cracks, breaks, and defective welds by welding.

(6) Replace any parts damaged beyond repair.

(7) Remove defective paint and corrosion. Treat and paint in accordance with service requirements.

c. Installation.

(1) Install relay table in reverse order of removal procedures.

(2) Refer to the Operator and Organizational Maintenance Manual and install housing assembly doors, covers, and panels.

Section II. LIFTING FRAME

**6-3. GENERAL.**

The lifting frame is securely attached to the skid base. It is equipped with lifting-clevises at the top of each side for lifting equipment attachment. In addition, the lifting frame provides support for the center of the housing assembly and serves as a mounting point for the hydraulic sump and the day tank assembly. During generator assembly removal, the lifting frame provides support for the rear of the engine assembly.

**6-4. LIFTING FRAME MAINTENANCE.**

a. Removal.

(1) Remove housing assembly doors and panels as required for lifting frame removal (paragraph 6-2).

(2) Remove hydraulic sump (paragraph 3-40).

(3) Remove fuel lines and fittings (paragraph 3-22) and day tank assembly (paragraph 3-18).

(4) Remove main fuel tank filler neck (paragraph 3-15).

(5) Remove lifting frame components by following the sequence of ascending index numbers (1 through 26) assigned to figure 6-2.

**NOTE**

It is not necessary to completely disassemble the lifting frame to replace a single part. Only those parts requiring repair or replacement need be removed.

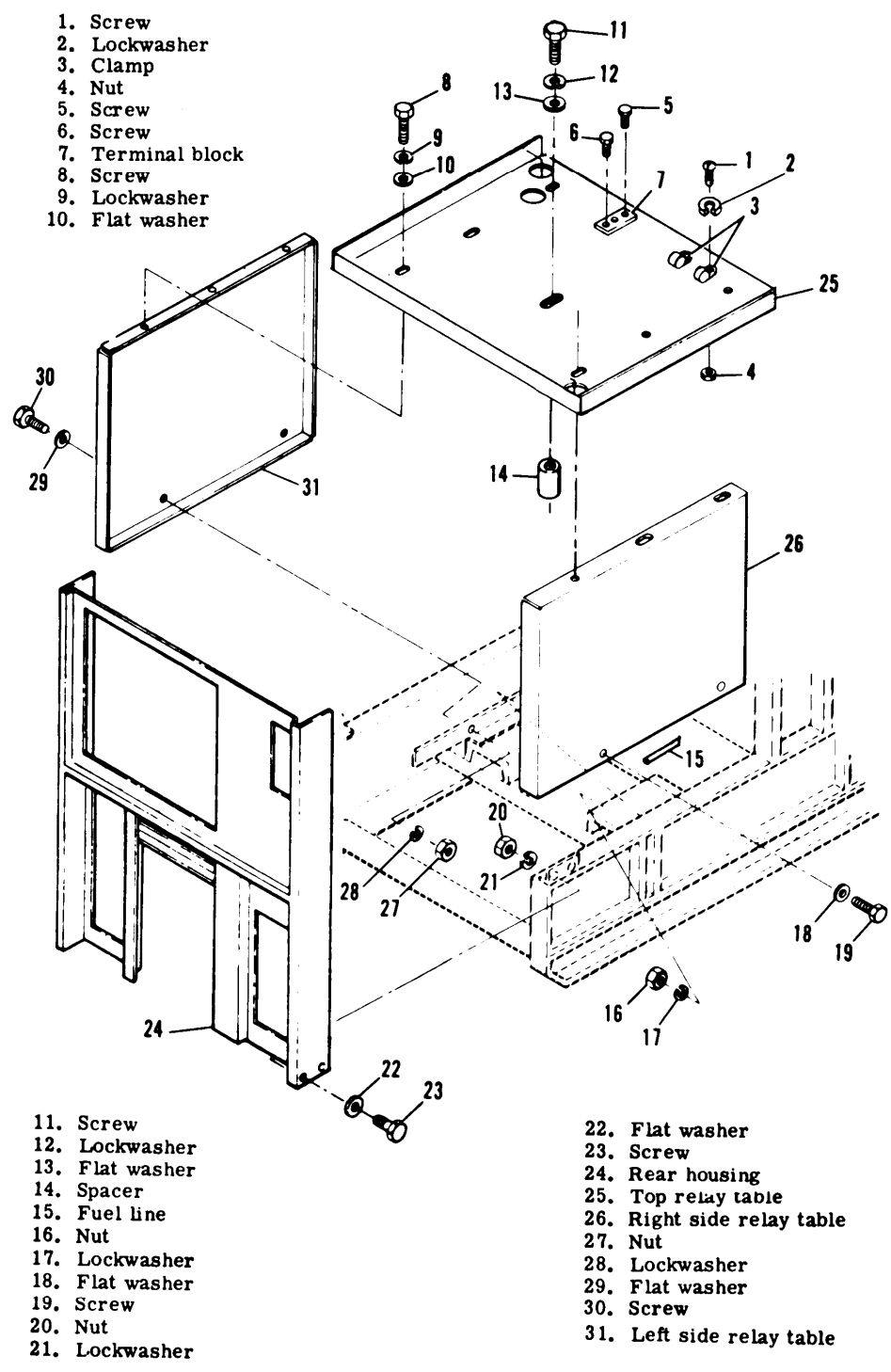

ME5-6115-465-34/6-1.1

Figure 6-1. Relay Table Assembly, Exploded View



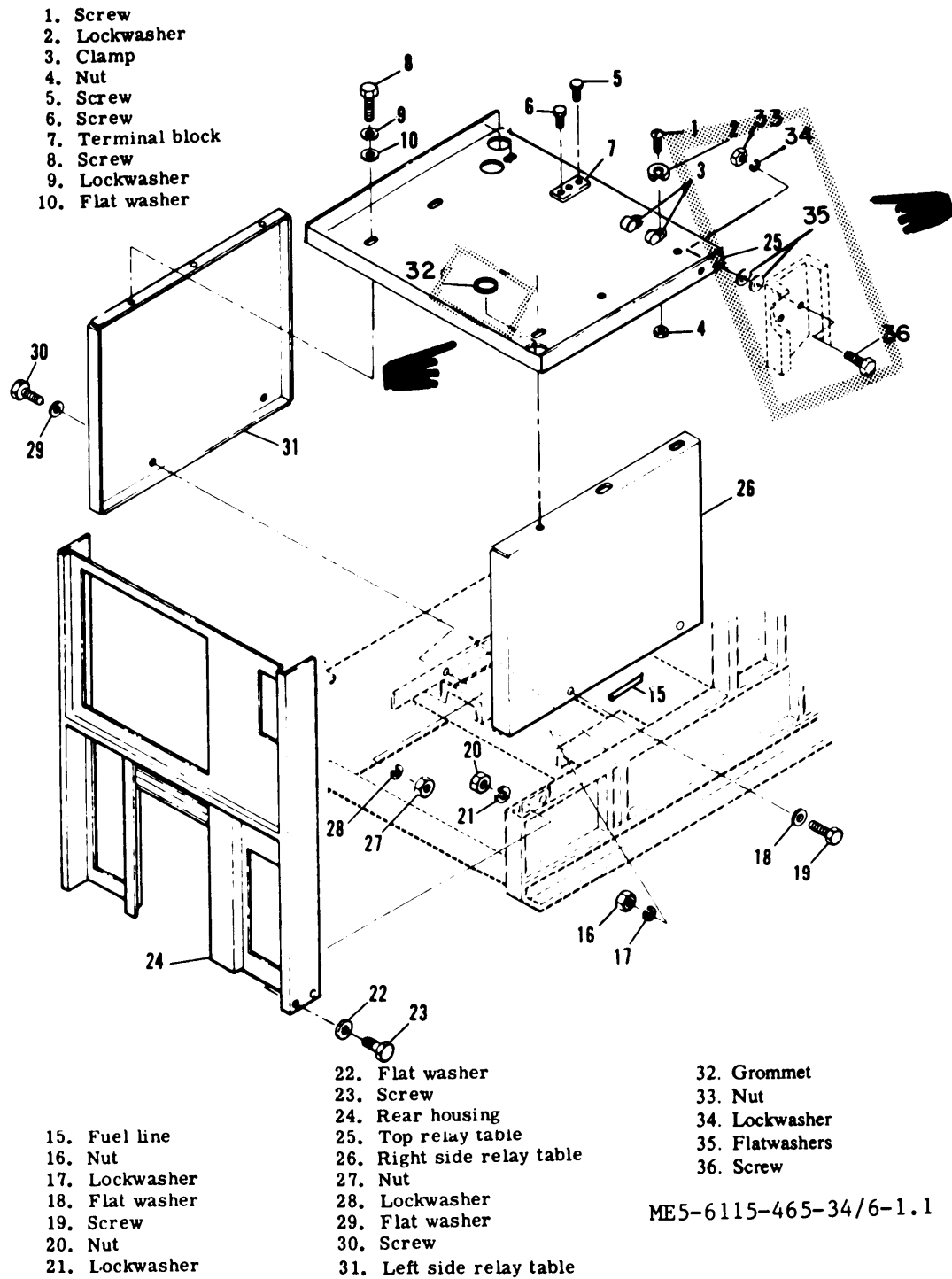

ME5-6115-465-34/6-1.1

Figure 6-1.1. Relay Table Assembly, Exploded View



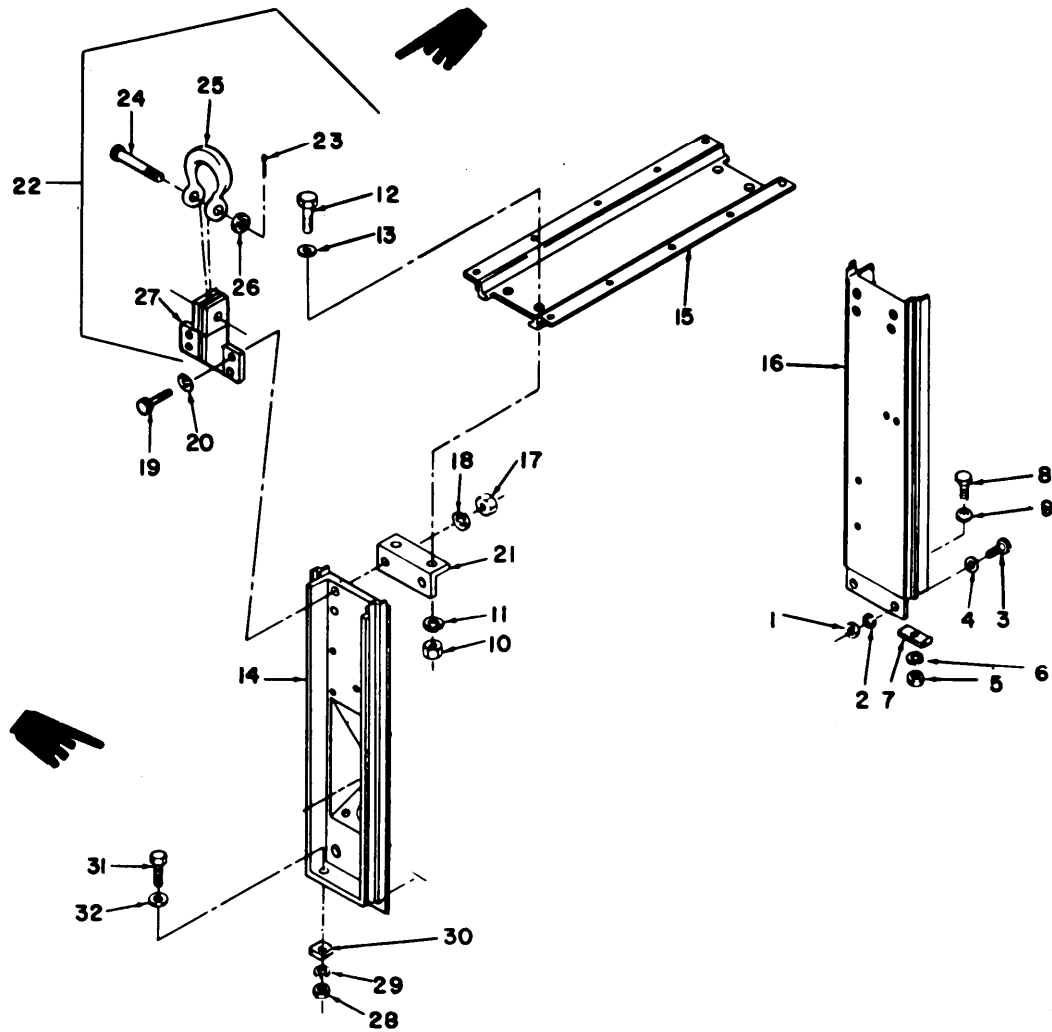

- |                |                     |                    |
|----------------|---------------------|--------------------|
| 1. Nut         | 12. Screw           | 23. Cotter pin     |
| 2. Lockwasher  | 13. Flatwasher      | 24. Bolt           |
| 3. Screw       | 14. Left support    | 25. Lifting Clevis |
| 4. Flatwasher  | 15. Top support     | 26. Nut            |
| 5. Nut         | 16. Right support   | 27. Clevis Bracket |
| 6. Lockwasher  | 17. Nut             | 28. Nut            |
| 7. Spacer      | 18. Lockwasher      | 29. Lockwasher     |
| 8. Screw       | 19. Screw           | 30. Hex nut        |
| 9. Flatwasher  | 20. Flatwasher      | 31. Screw          |
| 10. Nut        | 21. Bracket         | 32. Flatwasher     |
| 11. Lockwasher | 22. Clevis assembly |                    |

ME5-6115-465-34/6-2

Figure 6-2. Lifting Frame, Exploded View

b. Cleaning, Inspection, and Repair.

(1) Clean all parts in dry cleaning solvent (Federal Specification P-D-680) and dry thoroughly.

(2) Inspect supports, lifting clevises and brackets for cracks, corrosion, breaks, defective paint, and other damage.

(3) Inspect lifting clevises, brackets, and pins for excessive wear.

(4) Check all threads for crossing, stripping, and other damage.

(5) Repair cracks and breaks in supports by welding.

(6) Remove corrosion and defective paint. Treat and paint in accordance with service requirements.

(7) Replace all parts worn or damaged beyond repair.

c. Installation.

(1) Install lifting frame in reverse order of removal procedures.

(2) Install the housing assembly doors, covers, and panels, the hydraulic sump, the fuel lines and fittings, the day tank assembly, and the main fuel tank filler neck removed in steps a. (1) through a. (4) above.

### Section III. SKID BASE ASSEMBLY

#### 6-5. GENERAL.

The skid base assembly provides the mounting points for the engine assembly, the generator assembly, and the enclosure assembly. It contains the main fuel tank and the tool box. The generator set ground point is also contained in the skid base assembly. The skid base is also drilled to accept attachment of the wheel mounting kit. A metal sheet near the bottom of the skid base prevents the entry of debris. Drain holes are provided to prevent the accumulation of spilled liquids on the sheet.

#### 6-6. SKID BASE ASSEMBLY MAINTENANCE.

a. Removal.

(1) Refer to the Operator and Organizational Maintenance Manual and remove the housing assembly.

(2) Remove the relay table assembly (paragraph 6-2).

(3) Remove engine assembly (paragraph 2-6).

(4) Remove generator assembly (paragraph 2-7).

(5) Remove main fuel tank (paragraph 3-15).

(6) Remove the lifting frame (paragraph 6-4).

b. Disassembly, Disassemble skid base assembly by following the ascending sequence of index numbers (1 through 12) assigned to figure 6-3.

#### NOTE

It is not necessary to completely disassemble the skid base assembly to replace a single part. Only those parts requiring repair or replacement need be removed.

c. Cleaning, Inspection, and Repair.

(1) Clean all parts with dry cleaning solvent (Federal Specification P-D-680) and dry thoroughly. If necessary, use a stiff bristle brush to remove caked deposits.

(2) Visually inspect skid base for cracks, corrosion, defective paint and defective welds.

(3) Inspect tool box for cracks, corrosion, damaged latch and hinge, and defective paint. Replace tool box if damaged beyond repair.

(4) Inspect ground terminal stud for burns, corrosion, damaged threads or other damage. Replace if defects are noted.

(5) Repair cracks and defective welds in skid base by welding. File repairs to provide a smooth finish.

(6) Remove corrosion and defective paint. Treat and repaint in accordance with service requirements.

#### NOTE

Clean paint from ground terminal stud mounting to provide effective ground.

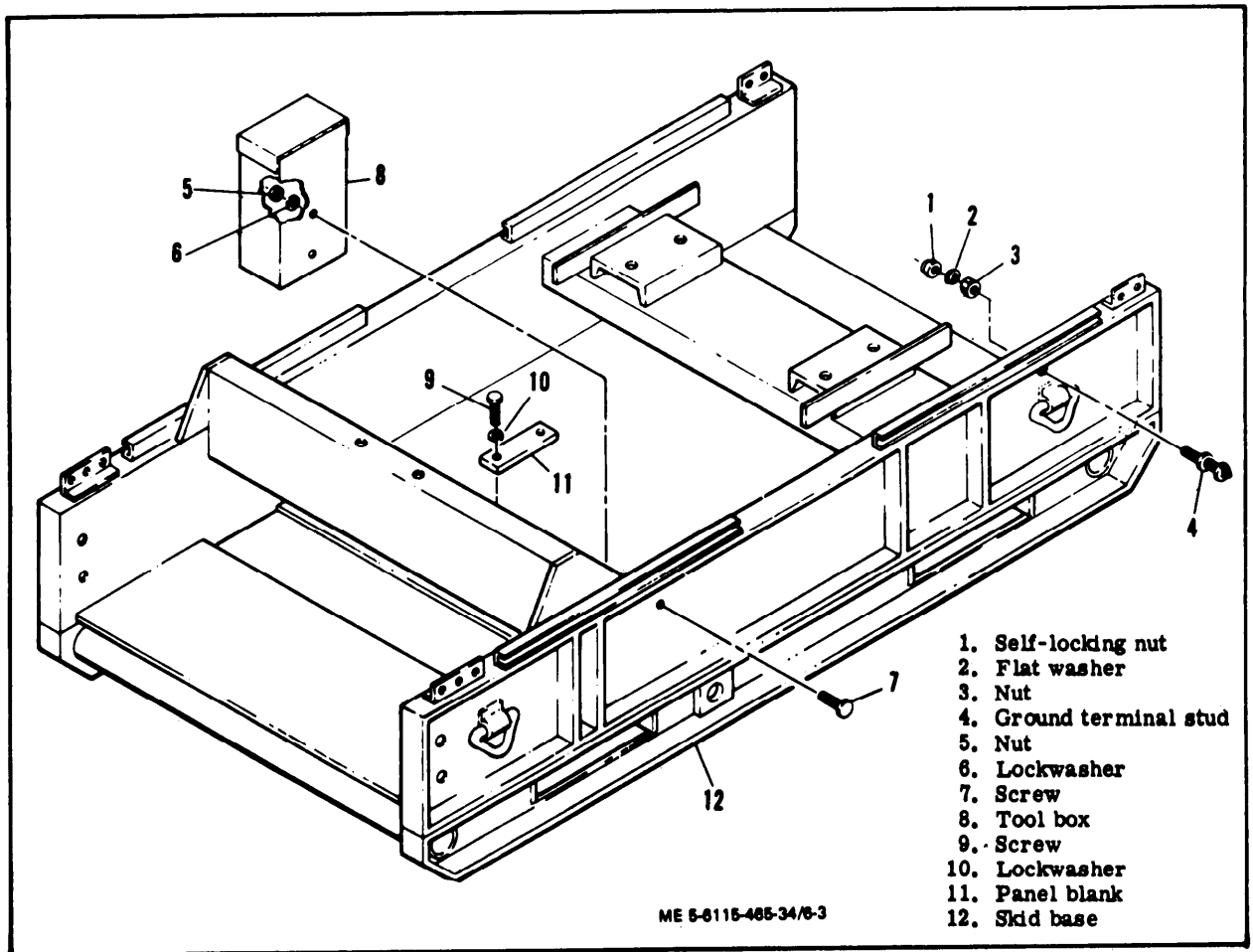

Figure 6-3. Skid Base Assembly, Exploded View

d. Assembly. Assemble skid base assembly in reverse order of disassembly procedures.

e. Installation.

(1) Install skid base assembly in reverse order of removal procedures.

(2) Install lifting frame, main fuel tank, generator assembly, engine assembly, relay table assembly, and housing assembly removed in subparagraphs a. (1) through a. (5) above.



CHAPTER 7  
GENERATOR SET TESTS AFTER OVERHAUL REPAIR INSTRUCTIONS

Section I. INSPECTION

7-1. GENERAL.

a. A thorough inspection of the generator set shall be conducted to insure that workmanship and materials are satisfactory.

b. The inspection shall be conducted each time the generator set is overhauled or rebuilt.

7-2. HOUSING AND FRAME INSPECTION.

a. Check that lifting eyes are installed and firmly secured.

b. Check that drain holes are open to prevent moisture accumulation.

c. Insure that exposed parts are properly treated to resist corrosion.

d. Open and close panel doors, engine area doors, and generator area doors to insure proper installation and freedom of motion.

e. Inspect movable door gasketing to insure that it is weatherproof.

f. Check that all caps and covers are equipped with ties, chains, or other ties to prevent loss.

7-3. ENGINE INSPECTION.

a. Check mounting bolts of all components and accessories to insure that they are firmly secured.

b. Check designation and data plates for legibility.

c. Insure that fuel and hydraulic oil lines are protected from damage due to vibration.

7-4. GENERATOR INSPECTION.

a. Insure that generator leads are properly identified and protected from damage due to vibration.

b. Insure that inspection openings are protected by screening or protective plates.

c. Check that the engine generator screws are firmly secured. See paragraph 1-6v. for proper torque values.

7-5. ELECTRICAL ACCESSORIES INSPECTION.

a. Check all cable and harness assemblies for secure fastenings and protection against chafing and vibration.

b. Insure that all cable and harness connectors are firmly secured in their proper place,

Section II. OPERATING TESTS

7-6. GENERAL.

a. The tests described in this section require generator set operation and provide verification of generator set performance characteristics.

NOTE

All tests shall be conducted with the 240/416 volt connections, unless otherwise specified. All tests that are applicable will be conducted on both Mode I and Mode II generator sets. Mode I tests shall be conducted at 60 Hz only unless otherwise specified.

b. Unless otherwise specified, all test instrumentation will be in accordance with Military

Standardization Handbook MIL-HDBK-705 and Military Standard MIL-STD-705.

c. Temperatures will be measured by means of appropriately located thermocouples and properly calibrated read-out devices. Thermocouples will be insulated from contact with other metals, as practical. Temperatures will be recorded in degrees Fahrenheit or Centigrade, depending on the instrument scale, but will be converted to degrees Fahrenheit in all cases. Barometric pressures will be measured by a mercurial barometer which will be corrected for the temperature of the scale, the mercury, for vapor pressure and for the location of the barometer with regard to altitude and latitude, Aneroid barometers will not be used.

d. Operation procedures required in support of the individual tests specified herein shall be performed

as in the Operator and Organizational Maintenance Manual.

e. All test results for generator set overhaul, shall be logged on the appropriate forms as required,

f. Perform the operating tests as indicated in table 7-1.

**7-7. DIRECTION OF ROTATION CONTROLS.**

With the generator set running at a rated load, rotate the following controls and verify their proper operation.

a. Frequency Adjust Control. On Class 1 sets clockwise rotation of the frequency adjust control rheostat must cause set frequency to increase as indicated on the frequency meter. On Class 2 sets counterclockwise rotation of manual speed control must increase frequency.

b. Voltage Adjust Control. Clockwise rotation of the voltage adjust control must cause set voltage to increase as indicated on the voltmeter.

c. Governor Paralleling Control (Class 1 Sets Only). Counterclockwise rotation of the governor paralleling control must cause an increase in the signal appearing at the paralleling receptacles.

d. Voltage Regulator Paralleling Control. Clockwise rotation of the voltage regulator paralleling control must cause that set to increase its share of the total reactive Kva.

**7-8. REVERSE POWER PROTECTIVE DEVICE TEST.**

a. Operate two generator sets in parallel at no load, with contactors closed.

b. Lower speed of set being tested until the main contactor opens.

c. Record the value on the kilowatt meter of the other set at the moment the contactor opens. The load contactor of the set under test must open when power flow into the generator exceeds 20 percent of the rated value.

**7-9. LOW FUEL PROTECTIVE DEVICE.**

a. Disconnect cable to the day tank fuel solenoid valve.

b. Operate generator set at full load.

c. The low fuel protective device must operate when the fuel in the day tank falls to a point at which there is only enough to operate the set at rated load for one minute.

**7-10. PARALLEL OPERATION PROVISIONS.**

a. For Class 1 (Precise) Sets (Real Power):

(1) Remove the shorting plug.

(2) With rated (30 kw) load on the generator set, measure the dc voltage across pins A and B of one of the paralleling receptacles (J45, J46, or J47), Adjust R28 (located on the precise relay box) until correct \*VDC is indicated, Ensure that correct \*pin is positive.

Governor Type	VDC * A.B	Positive * Pin
Electric	4	B
Electro-Hydraulic	4	A

b. For Class 1 (Precise) Sets (Reactive Power):

(1) Remove the shorting plug.

(2) With rated (30 kw) load applied with a .8 PF and the operation switch in the parallel position, measure the ac voltage across pins C and D of one of the paralleling receptacles (J45, J46, or J47). Adjust R29 (located on the special relay box) until 6 volts ac is achieved.

c. For Class 2 (Utility) Sets (Real Power), adjust governor droop as follows:

(1) Start and run engine until it reaches operating temperature.

(2) With rated (30 kw) load applied and the engine operating at rated speed, droop may be determined by removing load and noting no-load frequency.

(3) Adjust the knurled knob (15, Figure 3-18) located at the rear of the fuel pump, until the difference in frequency between no-load and full load is 3 percent. Note the increase of hertz when load is removed. At 60 Hz, droop should be 1.8 Hz, and at 400 Hz, droop should be 12.0 Hz.

d. For Class 2 (Utility) Sets (Reactive Power):

(1) Start and run engine until it reaches operating temperature.

(2) Install shorting plug.

(3) With rated (30 kw) load applied at .8 PF and the generator operating at rated voltage, voltage droop may be determined by removing the load and noting the difference between full-load and no-load voltage.

(4) Adjust R29 (located on the special relay box) until the difference in voltage between no-load and full load is 3 percent. Note the increase of volts when load is removed. At 120 volts, droop should be 3.6 volts.

7-11. Deleted.



7-12. MALFUNCTION INDICATOR TEST.

a. The malfunction indicator system is electrically isolated and independent of the protection system. Testing of the indicators can be accomplished at the same time that the protective devices are tested in tests, 6, 9, 10, 11, 12, 14, 15, 16, 17 and 18 of table 7-1.

b. In the event that one of the indicator circuits does not work, verify that the lamp is functional by operating the test and reset switch on the fault indicator panel.

7-13. PHASE BALANCE TEST VOLTAGE.

a. General. Polyphase electrical equipment may not operate properly or may be damaged if the phase voltages of a polyphase generator differ greatly from each other. Also, large differences between the phase

voltages of a polyphase generator may be an indication that the generator set has been improperly manufactured or damaged.

b. Apparatus. A frequency meter (or tachometer) as described and illustrated in MIL-HDBK-705, Method 104, or 109.1 and an rms indicating ac voltmeter having an accuracy of  $\pm 0.1\%$  of the reading shall be required to perform both procedures. A means of separately exciting the generator is required since procedure II is performed.

c. Generator With Separate Excitation.

(1) Preparation for test.

(a) Completely isolate the generator windings (armature coils and field windings).



Table 7-1. OPERATING TESTS

TEST	MIL-STD-705 PROCEDURE	TEST PARAMETER
1. Regulator and governor stability and transient response. (Short Term).	608.1a	See tables 7-2 and 7-3.
2. Overspeed protection device.	505.2a	2400 rpm to 2450 rpm.
3. Phase balance.	508.1c	See tables 7-2 and 7-3.
4. Circuit interrupter (Short Circuit).	512.1c	Instantaneously at 425 ± 25 percent of rated current.
5. Circuit interrupter (Overload Trip).	512.2c	8 ± 2 minutes at 130 percent of rated current.
6. Circuit interrupter (Undervoltage). (Class 1 sets only).	512.3c	Instantaneously below 48 volts, 6 ± 2 seconds at 99 ± 24 volts or less.
7. Circuit interrupter (Overvoltage).	512.3c	Not more than 1 second after voltage has risen to and remained at any value greater than 153 ± 3 volts for not less than 200 milliseconds.
8. Circuit interrupter (Under Frequency Trip).	514.1	60 Hz = 55 ± 1 50 Hz = 46 ± 1 400 Hz = 370 ± 5
9. Low oil pressure protective device.	515.1a	Trip pressure 17 ± 3 psi.
10. Reverse power protective device.		Refer to paragraph 7-8.
11. High coolant temperature protective.	515.2a	Trip temperature ±222 ± 3°F.
12. Low fuel protective device.		Refer to paragraph 7-9.
13. Regulator range.	511.1c	Test at both 50 Hz and 60 Hz for Mode I sets. See tables 7-2 and 7-3.
14. Phase sequence (Rotation).	507.1c	L1, L2, L3.
15. Frequency adjustment range.	511.2b	See tables 7-2 and 7-3.
16. Parallel operation provisions.		Refer to paragraph 7-10.
17. Malfunction indicator system.		Refer to paragraph 7-12.
18. Maximum power.	640.4	
a. 30kW, 50/60 Hz, TU and TP 42.2kW		
b. 30kW, 400 Hz, TU 24.2 kW		

CAUTION

Prior to performing any of the operating tests listed in table 7-1, insure that the generator set is serviced with the correct fuel, oil, and coolant as listed on the data plate.

Table 7-2. ENGINE GENERATOR SET CLASSIFICATION

CLASS	MODE	COMMON NAME	OUTPUT FREQUENCY	GOVERNING SYSTEM	SPECIAL COMPONENT COMPLEMENT	MODEL
1	I	Tactical Precise	50/60 Hz	Electro-Hydraulic, with backup manual governor	Electric governor control unit, hydraulic actuator, hydraulic pump and sump, precise relay assembly, special relay assembly, tactical relay assembly	MEP 104A
2	I	Tactical Utility	50/60 Hz	Mechanical (droop type)	Tactical relay assembly, special relay assembly	MEP 005A
1	II	Tactical Precise	400 Hz	Electric with backup manual governor	Electric governor control unit, electric actuator, magnetic pickup, tactical relay assembly, special relay assembly	MEP 114A

Table 7-3. ELECTRICAL PERFORMANCE CHARACTERISTIC PARAMETERS AC PRECISE (CLASS 1)

CHARACTERISTIC PARAMETER	VALUE	TEST METHOD MIL-STD-705
a. Voltage characteristic		
1. Regulation (%)	1	608.1
2. Steady-state-stabilty (variation)(bandwidth %)		
(a) Short term (30 seconds)	1	608.1
(b) Long term (4 hours)	2	608.2
3. Transient performance		
(a) Application of rated load		
(1) Dip 6)		
a. 60 Hz	15	810.2
b. 400 Hz	12	619.2
(2) Recovery (seconds)	0.5	619.2
(b) Rejection of rated load		
(1) Rise (%)		
a. 60 Hz	15	619.2
b. 400 Hz	12	619.2
(2) Recovery (seconds)	0,5	619.2
(c) Application of simulated motor load (twice rated current)		
(1) Dip 6)		
a. 60 Hz	30	619.1
b. 400 Hz	25	619.1
(2) Recovery to 95% of rated voltage (seconds) (See Note 1)	0.7	619.1
4. Waveform		
(a) Maximum deviation factor (%)	5	601.1
(b) Maximum individual harmonic (%)	2	601.4
5. Voltage unbalance with unbalanced load (%) (Note 2)	5	620.2
6. Phase balance voltage (%)	1	508.1
7. Voltage adjustment range		
(a) 50 Hz (120/208 volts) 50 Hz (240/416 volts)	190 to 213 volts 980 to 426 volts	511.1
(b) 60 Hz (120/208 volts) 60 Hz (240/416 volts)	197 to 240 volts 995 to 480 volts	511.1
(C) 400 Hz (120/208 volts) 400 Hz (240/416 volts)	197 to 229 volts 395 to 458 volts	511.1

Table 7-3. ELECTRICAL PERFORMANCE CHARACTERISTIC PARAMETERS  
 AC PRECISE (CLASS 1) (CONT)

CHARACTERISTIC PARAMETER	VALUE	TEST METHOD MIL-STD-705
b. Frequency characteristic		
1. Regulation (%)	0.25	608.1
2. Steady-state-stability (variation (bandwidth %))		
(a) Short term (30 seconds)	0.5	608.1
(b) Long term (4 hours)	1	608.2
S. Transient performance		
(a) Application of rated load		
(1) Undershoot (%)	1.5	608.1
(2) Recovery (seconds)	1	608.1
(b) Rejection of rated load		
(1) Overshoot (%)	1.5	608.1
(2) Recovery (seconds)	1	608.1
4. Frequency adjustment range (Hz)		
(a) 50 Hz	+2	511.2
(b) 60 Hz	+2	511.2
(c) 400 Hz	+20 -10	511.2

NOTE

1. The voltage shall stabilize at or above this voltage.
2. The generator set connected for three phase output and supplying a single phase, unity power factor load connected line-to-line, with no other load on the set. The load current to be 25 percent of the rated full load current of the set.

(b) Connect the frequency meter to one of the armature coils of the generator.

(c) Provide separate excitation for the exciter field.

(2) Test.

(a) Start and operate the generator at rated frequency and at no load.

(b) Adjust the excitation so that any one of the coil voltages is at rated value.

(c) Read and record the generator frequency (speed) and the voltage of each armature coil

d. Generator With Separate Excitation:

- (1) Determine from the data obtained in 7-13d.
- (2) the maximum and minimum armature coil voltages.

(2) The voltage unbalance is the difference between the maximum and minimum armature coil voltages. To express this in percent divide this difference by rated armature coil voltage and multiply by 100.

Voltage Unbalance (Coil), in percent -

$$\frac{V_{\max} - V_{\min}}{V_{\text{Rated}}} \times 100$$

(3) Compare the results of step (2) above with the requirements.

7-14. REGULATOR RANGE TEST.

a. "General. The voltage adjust device associated with the voltage regulator provided with the generator set must have adjustment capable of

varying the regulated voltage throughout the limits and under the various load conditions and temperature ranges without causing the voltage droop of the set to exceed specification limits. The voltage adjust device also must be capable in some cases of providing an operating voltage other than rated voltage for special types of equipment and to compensate for external line drop.

b. Apparatus. Instrumentation for measuring load conditions, ambient temperature, and the generator field (or exciter field) voltage and current shall be as described and illustrated in MIL-HDBK-705.

c. Procedure for Test.

(1) Preparation for test.

(a) Connect the load and field instrumentation in accordance with the applicable figure of MIL-HDBK-705, Method 205.1, Paragraph 205.1.10 for one voltage and frequency.

(2) Test.

(a) Start and operate the generator set and allow the set to stabilize at rated load, rated voltage and rated frequency. During this period record all instrument readings including thermal instrumentation at minimum intervals of 10 minutes. If necessary, adjustments to the load, voltage and frequency may be made to maintain rated load at rated voltage and frequency. Adjustments to the voltage and frequency may be made to maintain rated load at rated voltage and frequency. Adjustments to the voltage and frequency shall be limited to those adjustments available to the operator, specifically adjustments to the voltage or frequency adjust devices. On sets utilizing a droop type speed control system as the prime speed control, the speed and droop portions of the control may be adjusted. No other adjustments to the voltage and frequency control systems shall be made. Adjustments to load, voltage or frequency controls shall be recorded on the data sheet at the time of adjustment. Stabilization shall be considered to have occurred when four consecutive voltage and current readings of the generator (or exciter) field either remain unchanged or have only minor variations about an equilibrium condition with no evident continued increase or decrease in value after the last adjustment to the load, voltage, or frequency has been made.

(b) No further adjustments shall be made to any set control for the remainder of this test except the control panel voltage adjust device.

(c) Record all instrument readings.

(d) Remove load.

(e) Record all instrument readings (after transients have subsided).

(f) Adjust the terminal voltage to the maximum specified value.

(g) Record all instrument readings.

#### NOTE

At voltages above rated values, the generator will be supplying less than rated current; and at voltages below rated values, the generator will be supplying greater than rated current. Caution should be taken to avoid damage to instrumentation and load banks.

(h) Apply rated load (rated kW at rated power factor).

(i) Record all instrument readings (after transients have subsided).

(j) Remove load and adjust voltage to the maximum attainable value or to a value just prior to actuation of the overvoltage protection device.

#### NOTE

The output voltage may exceed the rating of connected equipment.

(k) Record all instrument readings (after transients have subsided).

(l) Apply rated load.

(m) Record all instrument readings (after transients have subsided).

(n) Adjust voltage to the minimum specified value at rated load.

(o) Record all instrument readings (after transients have subsided).

(p) Remove load.

(q) Record all instrument readings (after transients have subsided).

(r) Adjust voltage to the minimum attainable value or a value just prior to activation of the under voltage protection device.

(s) Record all instrument readings (after transients have subsided).

(t) Repeat steps (a) through (s) above for all other voltage connections).

d. Sample Calculations. Regulation (droop) is defined for the purposes of this method as the no-load value minus the rated load value divided by the rated load value the quantity expressed in percent.

% Regulation =

$$\frac{(\text{No-Load Voltage}) - (\text{Rated-Load Voltage})}{(\text{Rated- Load Voltage})} \times 100$$

e. Results. The data sheets shall indicate the voltage regulation as a percent of rated voltage within the specified limits at the minimum and maximum specified voltages and the regulation as a percent of rated voltage at the extremes, the maximum and minimum voltages attainable and the actuation of the protection devices (if applicable). Compare these results with the requirements of table 7-1.

#### 7-15. FREQUENCY AND VOLTAGE REGULATION, STABILITY, AND TRANSIENT RESPONSE TEST (SHORT-TERM).

a. General. The frequency regulation (sometimes referred to as droop) of a generator set is the maximum difference between the no load value of frequency and the value at any load up to and including rated load. This difference is expressed as a percentage of the rated frequency of the generator set. The voltage regulation is expressed similarly except that the rms value of voltage is used.

Frequency stability describes the tendency of the frequency to remain at a constant value. Generally, the instantaneous value of frequency is not constant but varies randomly above and below a mean value. Stability may be described as either short-term or long-term depending upon the length of time that the frequency is observed. Another term, bandwidth, describes the limits of these variations. Bandwidth is expressed as a percentage of the rated frequency of the generator set. Voltage stability is described similarly.

Frequency transient response describes the reaction of the frequency to a sudden change in some condition; such as, a load change on a generator set. This response consists of the amount of excursion beyond the mean of the new operating band, and the recovery time. The recovery time is the interval beginning at the point where the frequency leaves the original prescribed operating band and ending at the point where it enters and remains within the new prescribed operating band. The amount of surge is expressed as a percentage of the rated frequency of the generator set. The recovery time is expressed in seconds. The voltage transient response is described similarly.

b. Apparatus. Instrumentation for measuring load conditions, field voltage and current, and ambient temperature shall be as described and illustrated in MIL-HDBK-705. In addition, recording meter(s) for recording voltage and frequency shall be required.

c. Procedure.

(1) Preparation for test.

(a) Connect the load and field instrumentation in accordance with the applicable figure of

MIL-HDBK-705, Method 205.1, paragraphs 205.1.10, for one voltage and frequency. Connect the signal input of the recording meter(s) to the convenience receptacle of the set or to the generator coil which is used as the voltage sensing input to the voltage regulator. (Power the recording meter(s) from the commercial utility. )

(b) Set the recording meter chart speed(s) to a minimum of 5 inches per hour. The following items shall be recorded on both the data sheets and recording chart(s):

1. The date
2. The serial number(s) of the recording meter(s)
3. Generator set identification
4. The recording chart speed(s)
5. The data reading number

(c) Place all instrumentation referred to in paragraph 7-15b. in operation.

(2) Test.

(a) Start and operate the generator set and allow the set to stabilize at rated load, rated voltage and rated frequency. During this period operate the recording meter(s) at a chart speed of not less than 6 inches per hour, and record all instrument readings including thermal instrumentation at minimum intervals of 10 minutes. If necessary, adjustments to the load, voltage and frequency may be made to maintain rated load at rated voltage and frequency. Adjustments to the voltage and frequency shall be limited to those adjustments available to the operator, specifically adjustments to the voltage or frequency adjust devices. On sets utilizing a droop-type speed control droop portions of the control may be adjusted. No other adjustments to the voltage and frequency control systems shall be made. Adjustments to load, voltage or frequency controls shall be recorded on both the data sheet and the recording chart(s) at the time of an adjustment. Stabilization shall be considered to have occurred when four consecutive voltage and current recorded readings of the generator (or exciter) field either remain unchanged or have only minor variations about an equilibrium condition with no evident continued increase or decrease in value after the last adjustment to the load, voltage or frequency has been made.

(b) After stabilization has occurred, drop the load to no load and reapply rated load a number of times (three should be sufficient) to assure that the no load and rated load voltage and frequency values are repeatable and that the frequency and voltage regulation is within the limits specified in the procurement document. If any adjustments are necessary, paragraph (a) above must be repeated. Reapply rated load.

(c) The recording meter chart speed(s) shall be 12 inches per minute throughout the remainder



of this test, At each of the following load conditions (one step) operate the set for a minimum of 40 seconds (or the short-term stability period plus the allowable recovery time as specified in the procurement document). During each load condition read and record all instrument readings except thermal instrumentation (for three-phase sets it is not necessary to record line-to-line voltages). Each load condition shall be applied to the generator set in one step at the end of the short-term stability period for the previous load condition. The load conditions are:

1. Rated load
2. No load
3. Rated load
4. No load
5. Rated load
6. No load
7. Rated load
8. No load
9. 3/4 rated load
10. No load
11. 3/4 rated load
12. No load
13. 3/4 rated load
14. No load
15. 1/2 rated load
16. No load
17. 1/2 rated load
18. No load
19. 1/2 rated load
20. No load
21. 1/4 rated load
22. No load
23. 1/4 rated load
24. No load
25. 1/4 rated load
26. No load
27. Rated load
28. No load
29. Rated load
30. No load
31. Rated load
32. No load

(d) Repeat (a) through (c) for all voltage connection(s) and frequency(ies).

d. Results.

(1) Prepare a chart giving for each load change the momentary overshoot or undershoot and the recovery time. For each constant load, give the maximum voltage variation.

(2) Referring to figure 7-1 begin by determining the observed (B) and steady-state (D) voltage bandwidths.

(a) Mark numerically the stabilizations occurring after each load change, starting with the stabilization obtained before the first load change.

(b) Determine the observed voltage bandwidth (B) by marking the maximum trace excursion

and minimum trace excursion in the stabilized portion. Draw two lines parallel to the axis of chart movement, one each passing through these maximum and minimum trace excursions respectively.

(c) Draw a line (C) parallel to and equidistant from the edges of the observed voltage bandwidth. Determined in (b) above.

(d) Using the rated voltage of the generator and given requirements of table 7-1, calculate the steady-state voltage bandwidth (D). Draw this steady-state voltage bandwidth as two parallel lines, parallel to and equidistant from the median (C) at the observed voltage bandwidth.

(3) To determine the maximum voltage variation at constant load:

(a) One-half the observed voltage bandwidth (B) is the plus or minus value of voltage deviation at constant load.

(b) Divide each of the values obtained in (a) by the rated voltage of the generator and multiply by 100 to convert to percentage.

(4) To determine the maximum overshoot and undershoot at each load step, and express this as a percentage of its rated voltage, proceed as follows:

(a) From the meter recording charts, determine the maximum amount that the voltage trace goes beyond the line (3) of the observed voltage band following the load change. See figure 7-1 for illustration of overshoot and undershoot.

(b) Divide the result obtained in (a) by rated voltage (as given on the generator nameplate), then multiply by 100 to convert to percentage.

CAUTION

Do not use the constant operating voltage at each load as the divisor in the computation. Use only the rated voltage of the generator.

(5) To determine the time required to restore stable voltage conditions after each load change (recovery time):

(a) The prescribed steady state voltage bandwidth, extended to the point at which the voltage trace leaves the prescribed steady state band, shall be considered as the time at which the transient conditions begin. The point at which the voltage trace enters and remains within the prescribed band after a load change shall be considered as the point at which stabilization begins.

(b) Measure the distance (in inches) on the chart from the point where the voltage trace leaves the prescribed steady state band to the point where

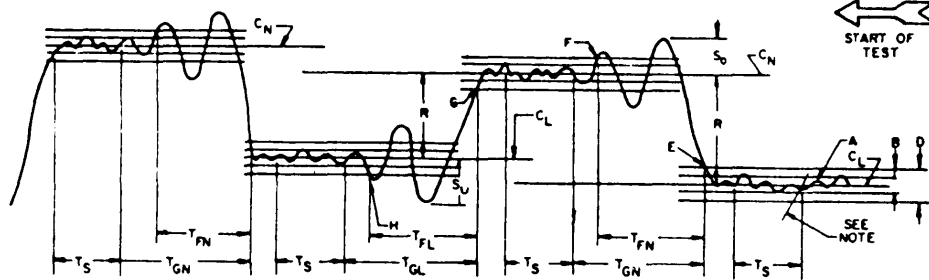

Trace and definitions apply to either voltage or frequency.

**NOTE**

Chart marked at start of test.

- |  |  |
|--|--|
| <p><b>A</b> Actual instrument trace of function.</p> <p><b>B</b> Observed steady-state band (two lines parallel to the axis of chart movement, one each passing through the center points of maximum and minimum trace excursion respectively during the short-term stability sample period, <math>T_S</math>).</p> <p><b>C</b> Mean of observed band.</p> <p><b>C<sub>L</sub></b> Mean value at selected load.</p> <p><b>C<sub>N</sub></b> Mean value at no load.</p> <p><b>D</b> Prescribed steady-state band.</p> <p><b>E</b> Point at which trace initially leaves prescribed load band under condition of decrease in load.</p> <p><b>F</b> Point at which trace enters and remains within prescribed no load band.</p> | <p><b>G</b> Point at which trace initially leaves prescribed no load band.</p> <p><b>H</b> Point at which trace enters and remains within prescribed load band.</p> <p><b>R</b> Regulation between any two loads.</p> <p><b>S</b> Surge after a load change.</p> <p><b>S<sub>O</sub></b> Overshoot</p> <p><b>S<sub>U</sub></b> Undershoot</p> <p><b>T<sub>FL</sub></b> Observed recovery time, no load to load.</p> <p><b>T<sub>FN</sub></b> Observed recovery time, load to no load.</p> <p><b>T<sub>G</sub></b> Maximum allowable recovery time.</p> <p><b>T<sub>GL</sub></b> Maximum allowable recovery time, no load to load.</p> <p><b>T<sub>GN</sub></b> Maximum allowable recovery time, load to no load</p> <p><b>T<sub>S</sub></b> Prescribed short-term sample time for determining stability.</p> |
|--|--|

ME 5-6115-485-34/7-1

Figure 7-1. Overshoot and Undershoot Chart Recording

it re-enters and remains within the prescribed voltage band for the next load condition.

(c) Divide this distance by the chart speed (in inches per second). This will give the voltage recovery time, in seconds.

(6) Determine the voltage regulation for all load changes (e. g. rated load to no load, 1/2 rated load to no load to 1/4 load, etc. ) as follows:

(a) Using the indicating voltmeter readings subtract the load value of voltage from the no load value for each load change (e. g. step (a) to step (b)). (For voltage regulators utilizing single-phase voltage sensing, the value of voltage in the sensed phase only shall be used in the above calculations. For voltage regulators utilizing multi-phase voltage sensing the average value of the sensed voltage shall be used. )

(b) Convert each of the values obtained in (a) above to a percentage of rated voltage by dividing by the rated voltage and multiplying by 100. This is the voltage regulation expressed in percent.

(c) Repeat paragraph 7-15d. (1) above substituting frequency for voltage.

(d) Compare the results tabulated in paragraphs 7-15d. (1) and 7-15d. (6)(c) with the requirements of Table 7-1.

#### 7-16. FREQUENCY ADJUST RANGE TEST.

a. General. It is necessary that the frequency of a generator set be adjustable to provide rated frequency at various load conditions as required in certain applications and to synchronize two or more generator sets for parallel operation.

b. Apparatus. Instrumentation for measuring had conditions, field voltage and current, and ambient temperature shall be as described and illustrated in MIL-HDBK-705.

c. Procedure.

(1) Preparation for Test. Connect the load and field instrumentation in accordance with the applicable figure of MIL-HDBK-705, method 205.1, paragraph 205.1.10.

(2) Test.

(a) Start and operate the generator set and allow it to stabilize at rated load, rated voltage and rated frequency .

During this period, readings of the load and field instrumentation shall be recorded at minimum intervals of 10 minutes. If necessary, adjustments to the load, voltage and frequency may be made to maintain rated load at rated voltage and rated frequency. However, adjustments available to the

operator, specifically adjustments to voltage and frequency adjust devices. Adjustments to the load, voltage or frequency shall be noted on the stabilization data sheet. Stabilization will be considered to have occurred when four consecutive voltage and current readings of the exciter field either remain unchanged or have only minor variations about an equilibrium condition with no evident continued increase or decrease in value after the last load, voltage or frequency adjustment has been made.

(b) No further adjustments shall be made to any set control for the remainder of this test except for the control panel frequency adjust device.

(c) For each of the conditions in the following steps allow approximately 2 minutes between each adjustment and the subsequent instrument readings.

(d) Adjust the generator set frequency for the specified maximum frequency at rated load. Read and record all instrument readings.

(e) Adjust the generator set frequency for the specified minimum frequency at rated load. Read and record all instrument readings.

(f) Reduce the load to zero.

(g) Adjust the generator set frequency for the maximum attainable frequency. Read and record all instrument readings. If the over frequency or overspeed protection device actuates, read and record all instrument readings just prior to the point of actuation and note on the data sheet that the protection device actuated.

#### NOTE

This step is not applicable to generator sets having governors that utilize a threaded shaft and lock nut(s) or other mechanical means as a method of operator speed adjustment.

(h) Adjust the generator set frequency for the minimum attainable frequency. Read and record all instrument readings.

#### NOTE

This step is not applicable to generator sets having governors that utilize a threaded shaft and lock (nuts) or other operator speed alignment.

(i) Repeat 7-16c (1) and 7-16c. (2)(a) through (f) for each frequency.

d. Results. The data sheet shall show the maximum and minimum frequencies attained at rated load, the maximum and minimum attainable frequencies at

no load and actuation of the protection devices (if applicable). Compare these results with the requirements of table 7-1.

#### 7-17. OVERSPEED PROTECTIVE DEVICE TEST.

a. General. To assure that adequate protection is afforded the generator set against overspeeding, the overspeed protective device must operate properly.

Apparatus. A frequency meter or tachometer as described and illustrated in MIL-HDBK-705, Methods 104.1 or 109.1 shall be required.

##### c. Procedure.

(1) Preparation for Test. Connect the frequency meter in accordance with the applicable figure of MIL-HDBK-705, Method 205.1, Paragraph 205.1.9 or utilize the tachometer in accordance with the manufacturer's instructions. Electronic governor and throttle stops must be deactivated.

##### (2) Test.

(a) Start and operate the "generator set at rated speed (frequency), rated voltage and no load.

(b) Slowly increase the engine speed until the overspeed protective device actuates. Record the speed of the generator set at this point, and the malfunction indicator light indication.

#### CAUTION

Do not operate the set in excess of 125 percent of rated speed or as otherwise limited in the procurement document.

(c) Attempt to start the set. Record if starting is achieved. If the set did not start, reset the overspeed protective device.

(d) Compare the test results with requirement of table 7-1.

#### 7-18. CIRCUIT INTERRUPTER TEST (SHORT CIRCUIT).

a. General. A circuit interrupter is connected between the generator voltage reconnection system and the generator set output terminals to disconnect the generator output from the load and also to protect the generator from a short circuit. The circuit interrupter is operated from a current sensor external to the interrupter.

b. Apparatus. Instrumentation for measuring load conditions shall be as described and illustrated in MIL-HDBK-705. In addition, a non-inductive shunt, "short-circuiting switch, galvanometers matching networks, an oscillograph as described and illustrated

in MIL-HDBK-705, Method 106.1, paragraph 106.1. S and galvanometers having a flat frequency response (flat within plus or minus five percent) from DC to 3.000 hertz will be required.

##### c. Procedure.

##### (1) Preparation for Test.

(a) Connect the load and instrumentation in accordance with the applicable figure of MIL-HDBK-705, Method 205.1, paragraph 205.1.10 for one voltage and frequency.

(b) Connect the shunt, galvanometers matching network, oscillograph, and short-circuiting switch as illustrated in figure 512.1.1.

##### (2) Test.

(a) Start and operate the generator set at rated voltage, rated frequency and rated load.

(b) Set the oscillograph time marker to a minimum of 0.01 seconds or use a 60 hertz timing trace set the chart speed such that the individual peaks of the current waveform are clearly visible and adjust the peak-to-peak rated current amplitude to a minimum of 0.5 inch for approximately 12 millimeters).

(c) Prior to closing the short-circuiting switch, record a portion of the steady state load for calibration. With the same load conditions record all instrument readings.

(d) With oscillograph still recording the steady state current, close the short-circuiting switch.

#### CAUTION

If the circuit interrupter fails to operate within the specified time, remove the short circuit to prevent damage. Note the failure to operate on the data sheet.

(e) The generator set contains a short-circuit malfunction indicator, check and record its indication\*

(f) Repeat steps (a) thru (e) above for each possible short circuit condition (**L<sub>1</sub>-L<sub>0</sub>, L<sub>2</sub>-L<sub>3</sub>, L<sub>1</sub>-L<sub>2</sub>-L<sub>3</sub> etc.**).

(g) Repeat steps (a) through (f) above for both voltage connections if applicable.

##### d. Results.

(1) From the oscillograms taken in 17-18c (2)(d), determine the time between the indicated closure of the short-circuiting switch and the opening of the circuit interrupter. See figure 512. 1-IL

(a) Calculate the short-circuit current using the peak-to-peak amplitudes of the current trace and the steady state ammeter reading prior to application of the short circuit. See figure 512. 1-II

(3) Tabulate the above results and the malfunction indicator indication for each line connection at each voltage connection and compare the results with the requirement in table 7-1.

#### 7-19. CIRCUIT INTERRUPTER TEST (OVERLOAD CURRENT)

a. General. A circuit interrupter is connected between the generator voltage reconnection system and the generator output terminals to disconnect the generator output from the load and to protect the generator from a sustained overload current. The circuit interrupter is operated from a current sensor external to the interrupter.

b. Apparatus. Instrumentation for measuring load conditions and field voltage and current shall be as described and illustrated in MIL-HDBK-705. In addition, a stopwatch or an oscillograph with galvanometers matching network and a non-inductive shunt as described and illustrated in MIL-HDBK-705, Method 106.1, paragraph 106.1.3 and galvanometers having a flat frequency respond (within plus or minus 5%) from dc to 3000 Hz.

c. Procedure.

(1) Preparation for test. Connect the load and field instrumentation in accordance with the applicable figure of MIL-HDBK-705, Method 205.1, paragraph 205.1.10 for one voltage and frequency.

#### CAUTION

If the circuit interrupter fails to operate within the time specified in table 7-1 at any time during the performance of this method, manually open the circuit interrupter and reduce the load impedance to rated value before reclosing the circuit interrupter. Record on the data sheet the failure of the interrupter to operate and the total elapsed time the overload was on the set.

(a) Start and operate the generator set at rated voltage, rated frequency and rated load.

(b) Allow the generator set to stabilize at rated load, voltage and frequency. During this period, readings of the load and field instrumentation shall be recorded at minimum intervals of 10 minutes. If necessary, adjustments to the load, voltage and frequency may be made to maintain rated load at rated voltage and frequency. Adjustment to the load, voltage or frequency shall be noted on the data sheet. Stabilization will be considered to have occurred when four

consecutive voltage and current readings of the exciter field either remain unchanged or have only minor variations about an equilibrium condition with no evident continued increase or decrease in value after the last load, voltage or frequency adjustment has been made.

(c) In one step, increase the load current to the overload current value specified in table 7-1 (the increase in current may be accomplished by any practical means, e.g. reactively or using reduced voltage levels).

#### NOTE

The frequency shall be maintained at rated conditions, the load current shall be kept constant and the load current shall be balanced equally among the phases. Simultaneously with the load current increase, start the stop watch.

(d) Record all load instrumentation and the time, in seconds, required for the circuit interrupter to operate.

(e) The generator set contains an overload malfunction indicator. Check and record its indication.

(f) Allow the generator set to cool at rated load for a minimum of 15 minutes.

(g) Repeat steps (c) thru (f) except that the load current is increased to the overload current value in Phase A only. Phases B and C remain at the rated load current value.

(b) Repeat step (g) except that the load is increased to the overload current value in phase B only. Phases A and C remain at the rated load value of current.

(i) Repeat step (g) except that the load is increased to the overload current value in phase C only. Phases A and B remain at the rated load value of current.

d. Results. The data sheets shall show, as a minimum, whether or not the circuit interrupter operated, the time(s) required for the interrupter to operate, the indication of the malfunction indicator, the overload conditions ) and the stabilization data. Compare the time(s) requirements of table 7-1.

#### 7-20. CIRCUIT INTERRUPTER TEST (OVER VOLTAGE AND UNDER VOLTAGE).

a. General. To protect the load from generator malfunction (e. g., overvoltage or undervoltage) a circuit interrupter is connected between the generator voltage reconnection system and the generator output terminals. A voltage sensing circuit operates the circuit interrupter if an overvoltage or undervoltage condition occurs and thus protects the load from a generator malfunction.

b. Apparatus. Instrumentation for measuring voltage and frequency shall be as described and illustrated in MI L-HDBK-705. Resistors, galvanometers matching networks, an oscillogram (as described and illustrated in MIL-HDBK-705, Method 106.1, paragraph 106. 1.3 ) and galvanometers having a minimum flat frequency response (flat within plus or minus 5 percent) from DC to 3000 Hertz and the voltage divider transformer network will be required.

c. Procedure I. (Overvoltage).

(1) Preparation for test.

(a) Locate and disconnect the input circuit to the input terminals of the overvoltage protective sensing circuit and connect the apparatus as illustrated in figure 512.3-I for one voltage connection.

(b) Connect the frequency meter to the output terminals of the generator set.

(2) Test.

(a) Start and operate the set at rated frequency and no load.

(b) Close the switch (see figure 512.3-I) and use resistance, R1 to adjust the voltage to the overvoltage value specified in table 7-1. The set has provisions for shutdown upon an overvoltage condition. It will be necessary to temporarily deactivate this provision to permit adjustment of the overvoltage value. This may be done by activation of the "protective bypass" (Battle Short ) switch. Do not deactivate the circuit interrupter trip circuitry.

(c) Open the switch, reset the overvoltage circuit and adjust the resistance, R2, until voltmeter No. 2 reads rated voltage.

(d) Repeat (b) and (c) to assure that the specified overvoltage and rated voltage settings are correct.

(e) Set the oscillograph chart speed such that the individual waveform peaks are clearly visible. Set the timing lines to a minimum of 0.01 seconds per line or use a 60 Hertz time trace. Adjust the trace peak-to-peak amplitude to a minimum of one inch (or 25 millimeters).

(f) Read and record both voltmeter readings.

(g) With the oscillograph recording and the circuit interrupter closed, close the switch. (See figure 512.3-1).

(h) Reactivate the shutdown provision if used.

(i) The generator set contains an overvoltage malfunction indicator; check and record its indication.

(j) Record whether or not the set shuts down.

(k) Open the switch, reset the overvoltage circuit if necessary, restart the set if required, and close the circuit interrupter.

(1) Repeat steps (e) thru (k) above two additional times.

d. Procedure II (Undervoltage).

(1) Preparation for test.

(a) Locate the input terminals of the undervoltage sensing circuit and connect the apparatus as illustrated in figure 512.3-I.

(b) Repeat step (b) of para. 7-20c. (1)(b).

(2) Test.

(a) Start and operate the set at rated frequency and no load.

(b) Close the switch (see figure 512.3-I) and use the resistance, R1, to adjust the voltage to the rated value.

(c) Open the switch and adjust the resistance, R2, until Voltmeter No. 2 reads the undervoltage value specified in table 7-1. This test shall be repeated for each undervoltage value.

(d) Repeat steps (b) and (c) above to assure that the specified undervoltage and rated voltage settings are correct.

(e) Set the oscillograph chart speed such that the individual waveform peaks are clearly visible. Set the timing lines to a minimum of 0.01 seconds per line or use a 60 Hertz timing trace. With the switch open, adjust the trace peak-to-peak amplitude to a minimum of one inch (or 25 millimeters).

(f) With the set operating and the circuit interrupter and the switch open, read and record both voltmeter readings.

(g) Close the switch and circuit interrupter.

(h) With the oscillograph recording, open the switch.

(i) After allowing sufficient time for the circuit interrupter to operate, check and record the indication of the undervoltage malfunction indicator.

(j) Close the switch and close the circuit interrupter.

(k) Repeat steps (e) thru (j) above two additional times.

(l) Repeat (a) thru (k) for the other under-voltage value specified in para. 7-1.

e. Results.

(1) From the oscillograms made in 7-20c. determine and tabulate the time between the application of the overvoltage and operation of the circuit interrupter for each application of overvoltage.

(2) From the oscillograms made in 7-20d. determine and tabulate the time between the application of the undervoltage and the operation of the circuit interrupter for each application of undervoltage.

(3) Compare these results with the requirements of table 7-1.

7-21. LOW OIL PRESSURE PROTECTIVE DEVICE TEST.

a. General. Since generator sets frequently operate unattended for long periods, the engine is equipped with a low oil pressure protective device. This device shuts down the engine when the oil pressure drops below the safe limit.

b. Apparatus. The following equipment shall be required to perform this test.

- Oil pressure gauge ( $\pm 1\%$ )
- Flexible oil line (or copper tubing)
- Regulating valves
- Brass fittings.

c. Procedure.

(1) Preparation for test. With the set not operating, remove the protective device tap from the engine block and reconnect as shown in figure 515. 1-1 with the protective device and oil pressure gauge in approximately the same horizontal plane as the protective device tap located on the engine.

(2) Test.

(a) With the bleeder valve closed and the shut-off valve in the oil pressure line open, start and operate the set at rated speed (use the set instrumentation) and at no load.

(b) Open the bleeder valve slightly to purge air from the system.

(c) Close the bleeder valve and record the oil pressure as indicated on the external gauge.

(d) Almost completely close the shut-off valve.

(e) Slowly open the bleeder valve until the low oil pressure protective device shuts down the engine. Record the reading of the oil pressure gauge at the point of set shutdown (see figure 515. 1-II).

(f) Record operation of the malfunction indicator light.

d. Results. Compare the value of shutdown pressure with the requirement of table 7-1.

7-22. OVERTEMPERATURE PROTECTIVE DEVICE TEST.

a. General. The overtemperature device must be capable of protecting the engine in the set against overheating for any reason.

b. Apparatus. Instrumentation for measuring load conditions and set and ambient temperatures shall be as described and illustrated in MIL-HD13K-705, Method 205.1, Paragraph 205.1.10.

c. Procedure.

(1) Preparation for test.

(a) Connect the load instrumentation in accordance with the applicable figure of MIL-HDBK-705, Method 205.1, Paragraph 205.1.10.

(b) Install a thermocouple to measure the same temperature as seen by the protective device sensor.

(2) Test.

(a) Start and operate the generator set at rated voltage, rated frequency (speed), and rated load.

(b) Block the cooling air to the generator set by any suitable means.

(c) Continuously monitor the temperature seen by the thermocouple installed in paragraph 7-22c. (1)(b) above. Record the temperature at which the overtemperature protective device actuates. Record the temperature at which the coolant temperature indicator illuminates.

CAUTION

If the engine fails to shutdown when the temperature exceeds the maximum trip value specified in table 7-1, the test shall be immediately discontinued.

d. Results. Compare the results with the requirement of table 7-1.

7-23. PHASE SEQUENCE TEST (ROTATION).

d. General. Unless the phase sequence (rotation) of the load terminals of a three-phase generator set is

correct, serious damage or injury could be done to connected equipment and to personnel as a result of reversed motor rotation or excessive current surges.

b. Apparatus. A phase sequence (rotation) indicator as described and illustrated in MIL-HDBK-705, Method 116.1 or a three-phase motor whose direction of operation in relation to phase sequence is known shall be required.

c. Procedure.

(1) Connect the generator set load terminals to the applicable test apparatus for one of the set three-phase voltage connections. Re-check the connections to insure that **L<sub>1</sub>, L<sub>2</sub> and L<sub>3</sub>** of the generator set are connected to **L<sub>1</sub>, L<sub>2</sub> and L<sub>3</sub>** of the test apparatus respectively.

(2) Start and operate the generator set at rated voltage and frequency. The set indicating instruments shall be sufficient indication of output voltage and frequency.

(3) Close the circuit interrupter and determine the direction of phase sequence (rotation) by observing the indicator, or by noting the direction of rotation if a three-phase motor is used. Record results.

(4) Check the phase sequence (rotation) of the power output of each power receptacle on the generator set by connecting the applicable test apparatus to the receptacle and repeating steps (1) thru (3) above.

(5) Repeat steps (a) thru (d) above for all other three-phase voltage output connections of the generator set.

d. Results. The phase sequence (rotation) as indicated by the test shall be checked against the requirements of table 7-1.

#### 7-24. MAXIMUM POWER TEST.

a. General. The maximum power of a generator set is a function of the ambient conditions (temperature and altitude) and the mechanical condition of the engine at any particular time.

b. Apparatus. Instrumentation for measuring load conditions, field voltage and current, pressures and temperatures shall be as described and illustrated in MIL-HDBK-705.

#### CAUTION

This procedure subjects the generator set to a severe overload which may be damaging if maintained for too long a period of time.

(1) Preparation for test.

(a) Connect the load and instrumentation in accordance with the applicable figure of MIL-HDBK-705, Method 205.1, paragraph 205.1.10 for one voltage and frequency.

(b) Install appropriate thermocouples to measure the following temperatures:

1. Engine coolant (engine outlet and inlet)
2. Exhaust gas(es) (the exhaust manifold(s) shall be drilled and tapped as close as possible to the combustion chamber(s).)
3. Lubricating oil sump.
4. Engine combustion air in (located at the inlet of the intake manifold).

(c) Install appropriate pressure instrumentation to measure the following items:

1. Exhaust pressure (combined exhaust gases in exhaust manifold).
2. Intake air manifold pressure (between air filters and manifold).

(d) Obtain and record the barometric and water vapor pressures (see MIL-HDBK-705, Method 220. 2).

(e) Bypass the set circuit interrupter.

(f) Connect the set to a source of fuel containing a specified fuel required by the procurement document.

(2) Test.

(a) Start and operate the generator set and allow it to stabilize at rated load, rated voltage and rated frequency (speed). During this period, readings of all instruments including thermal instrumentation shall be recorded at minimum intervals of 10 minutes. If necessary, adjustments to the load, voltage and rated frequency. However, adjustments to the voltage and frequency shall be limited to those adjustments available to the operator, specifically adjustments to the voltage or frequency adjust devices. On generator sets utilizing a droop-type speed control system as the prime speed control, the speed and droop portions of the control may be adjusted. No other adjustments to the voltage and frequency control systems shall be made. Adjustments to the load, voltage or frequency controls shall be recorded on both the data sheet and recording chart(s). Stabilization will be considered to have occurred when four consecutive voltage and current recordings of the exciter field either remain unchanged or have only minor variations about an equilibrium condition with no evident continued increase or decrease in value after the last adjustment to the load, voltage or frequency has been made.

(b) Perform this test using resistive load only. Remove reactive load after stabilization.



(c) For Class II Sets:

1. Alternately increase the load, voltage and frequency in small increments until the fuel system controls are in the maximum fuel position as permitted by the governor control linkage and the voltage and frequency are within 1 percent of their rated values.

**NOTE**

Small increments should be taken to avoid passing the maximum power at the rated voltage and frequency point and to avoid racing or bogging the engine.

2. Hold the conditions in step (1) above for two minutes. However, if the voltage and frequency cannot be maintained within 1 percent of their rated values, the load must be adjusted to the point at which the voltage and frequency can be maintained within 1 percent of the rated value for two minutes.

**CAUTION**

It may be necessary to reduce the load to a value below the rated kilowatt load for a short period of time to prevent serious overheating or damage to the generator set if the conditions can not be readily attained. (Monitor instrumentation.)

3. At the end of the two minute interval record all instrument readings including thermal instrumentation.

4. Reduce the load to approximately rated kilowatt load and allow the generator set to cool for approximately 5 to 10 minutes.

5. Repeat steps (1) through (4) above until three valid sets of maximum power data are obtained.

(d) For Class I Sets:

Repeat step (c) above but do not adjust the frequency.

2. Repeat steps (a) through (c) above as applicable for all other voltage connections and frequencies.

(e) Results.

1. Average the three valid power readings. This average is the observed maximum power value.

2. Correct the observed maximum power value to standard conditions using the procedure in MIL-HDBK-705, Method 220.2, paragraph 220.2.3. This is the corrected maximum power value.

3. Compare these results with the requirements of table 7-1.

7-25. **UNDER FREQUENCY PROTECTIVE DEVICE TEST.**

**General.** For generators that power certain type; of equipment, it is extremely important that the circuit interrupter open when the frequency fails appreciably below rated value. Severe damage may otherwise result to the powered equipment. To insure that the circuit interrupter will open at or before the critical frequency value, the generators are equipped with an under frequency protective device. The device on this generator operates electrically. Although the under frequency protective device must be capable of functioning at any voltage throughout the specified voltage operating range, it is necessary only to perform the test at the specified maximum, at rated, and at minimum voltage limits.

b. **Apparatus.** Instrumentation for measuring load conditions shall be as described and illustrated in method 205.1, paragraph 205.1.10 of MIL-HDBK-705.

c. **Procedure.**

(1) Preparation for test. Connect a voltmeter and frequency meter to the generator set terminals, ahead of the circuit interrupter, and the remainder of the apparatus as shown in the applicable figure of paragraph 205. 1. 10 of MIL-HDBK-705.

(2) Test.

(a) Operate the generator at rated speed and voltage, and at no load since the generator is equipped with an electrical-type underfrequency protective device, this test shall be repeated with the voltage adjusted to maximum and minimum voltage for the specified voltage operating range.

(b) With the circuit interrupter closed, slowly decrease the operating speed until the protective device causes the circuit interrupter to open. The electric governor must be deactivated to sufficiently decrease the speed on Class 1, precise sets.

(c) Record the speed.

(d) Repeat the test while rapidly decreasing the operating speed. Again record the speed.

(e) Operate the generator at rated speed and voltage, and at rated load.

(f) Repeat steps (b), (c) and (d).

d. **Results.** Compare the test value of frequency with that given in table 7-1.



CHAPTER 8

REPAIR INSTRUCTIONS FOR MATERIAL USED IN CONJUNCTION WITH THE GENERATOR SET

Section I. FUEL BURNING WINTERIZATION KIT

8-1. GENERAL.

The fuel burning winterization kit is used to pre-heat engine coolant and lubricating oil to facilitate starting at ambient temperatures between -25°F (-31.7°C) and -65°F (-53.9°C). It consists of a heater and coolant pump assembly, a heater control assembly, coolant circulating lines and fittings and wiring harness. Fuel for heating the coolant is supplied from the generator set main fuel tank by the fuel transfer pumps. Electrical power for coolant pump operation is supplied from the generator set batteries.

8-2. TROUBLESHOOTING.

Table 8-1 contains a listing of malfunctions which is useful in diagnosing and correcting unsatisfactory operation or failure of the fuel burning winterization kit. Each malfunction is followed by an alphabetical listing of probable causes of the malfunction. The corresponding alphabetical listing of corrective actions contains references to the applicable maintenance paragraph for correcting the cause of each malfunction.

NOTE

Refer to the Operator and Organizational Maintenance Manual for troubleshooting information applicable to lower levels of maintenance.

Table 8-1. FUEL-BURNING WINTERIZATION KIT TROUBLESHOOTING CHART

MALFUNCTION	PROBABLE CAUSE	CORRECTIVE ACTION
1. Press-to-test lamp does not illuminate	a. Faulty circuit breaker. b. Open circuit.	a. Replace circuit breaker (para. 8-3). b. Check circuit.
2. Switch on, nothing happens	a. Faulty circuit breaker. b. Open circuit.	a. Replace circuit breaker (para. 8-3). b. Check circuit.
3. Switch on, heater will not ignite; blower operates	a. Defective igniter. b. Metering orifice clogged. c. Pressure regulator solenoid closed.	a. Replace igniter (para. 8-4). b. Clean orifice (para. 8-4). c. Check regulator valve. Replace if defective (para. 8-4).
4. Fan runs with switch off	a. Broken quartz rod. b. Flame switch out of adjustment.	a. Replace rod (para. 8-4). b. Adjust flame switch (para. 8-4).
5. Heater starts, then goes out	a. Faulty micro-switch. b. Overheats, trips limit switch	a. Replace switch (para. 8-4). b. Check fuel regulator delivery rate. Adjust as required (para. 8-4).
6. Circuit breaker opens	Short circuit.	Disconnect basic components, one at a time to isolate short (para. 8-4) - then check wiring (para. 8-6).

Table 8-1. FUEL-BURNING WINTERIZATION KIT TROUBLESHOOTING CHART (CONT)

MALFUNCTION	PROBABLE CAUSE	CORRECTIVE ACTION
?. Failure to shut off	a. Fuel regulator valve stuck open. b. Flame switch stuck open.	a. Replace valve (para. 8-4). b. Adjust or replace (para. 8-4).
8. Surging combustion	Fuel regulator operating erratically.	Check fuel rate and replace valve if necessary (para. 8-4).
9. Coolant pump fails to recirculate liquid	a. Faulty coolant pump. b. Clogged coolant line.	a. Repair or replace pump (para. 8-4). b. Unclog or replace coolant line (para. 8-5).
10. Coolant pump turns over but fails to deliver fluid	a. Pump passages or blade slots plugged with foreign matter. b. Defective motor.	a. Repair or replace pump (para. 8-4). b. Replace motor (para. 8-4).
11. Erratic or reduced output	a. Air leak. b. Reduced voltage. c. Motor lag, low rpm. d. Scored cam ring bore. e. Foreign matter in pump blade slots.	a. Check tubing connections for leaks (para. 8-5). b. Check voltage input to motor (para. 8-4). c. Check motor brushes for excessive wear (para. 8-4). d. Replace the cam ring (para. 8-4). e. Remove pump from motor; disassemble and clean pump and filter (para. 8-4).
12. Leakage	a. Face of seal cage scored or damaged seal o-ring. b. Seal face of adapter scored.	a. Disassemble and inspect seal cage face and o-ring. Refinish or replace as required (para. 8-4). b. Disassemble and inspect seal surface. Refinish or replace the adapter (para. 8-4).
13. Motor failure	a. Worn brushes b. Worn bearings. Burned armature.	a. Remove and replace (para. 8-4). b. Remove and replace (para. 8-4). Replace motor (para. 8-4).

### 8-3. HEATER CONTROL ASSEMBLY.

a. Removal. Refer to the Operator and Organizational Maintenance Manual for heater control assembly removal instructions.

b. Disassembly.

(1) Disassemble heater control assembly by following the ascending sequence of index numbers (1 through 21) assigned to figure 8-1).

(2) Tag all electrical leads before disconnecting.

c. Cleaning, Inspection, and Repair.

(1) Clean all electrical parts with filtered compressed air and a soft bristle brush. If necessary, caked deposits may be removed with a clean, lint-free cloth moistened with an approved solvent.

(2) Clean all non-electrical parts with a clean, lint-free cloth moistened with dry cleaning solvent (Federal Specification P-D-680).

(3) Inspect ON-OFF switch for cracked casing, corrosion, and burns or other evidence of shorting.

(4) Place switch in the ON position and check for continuity, using an ohmmeter. Ohmmeter shall indicate continuity. Check for open circuit with switch in the OFF position. Ohmmeter shall indicate open circuit.

(5) Inspect circuit breaker for cracked casing, corrosion, and burns or other indications of shorting.

(6) Using an ohmmeter, check for open circuit across circuit breaker terminals. Ohmmeter shall indicate open circuit. Depress circuit breaker button. Ohmmeter shall indicate continuity.

(7) Inspect indicator light lens for cracked or broken glass, corrosion, and other damage.

(8) Inspect lamp for cracked or broken glass, burned out filament and corrosion.

(9) Check indicator light base for cracks, corrosion, and burns.

(10) Inspect wiring harness for damaged connectors, wires, and terminals. Check individual wires for continuity using figure 8-2 as a guide.

(11) Replace damaged connectors and terminals by unsoldering and removing electrical leads. Install replacement part, make mechanical connections and solder in accordance with established procedure.

(12) Replace defective wires using wire conforming to Military Specification MIL-W-5086, Type II.

(13) Inspect housing for cracks, warping, and corrosion.

(14) Inspect all threads for crossing, stripping, and other damage.

(15) Replace all damaged or defective parts.

d. Assembly. Assemble fuel burning heater control assembly in reverse order of removal procedures.

e. Installation. Refer to the Operator and Organizational Maintenance Manual for fuel burning winterization heater control assembly installation instructions.

### 8-4. HEATER ASSEMBLY.

a. Removal. Refer to the Operator and Organizational Maintenance Manual for heater assembly removal instructions.

b. Disassembly. Disassemble fuel burning heater assembly by following the sequence of ascending index numbers (1 through 75) assigned to figure 8-3 while observing the following:

(1) Tag or otherwise identify electrical leads as they are disconnected to facilitate installation.

(2) Conspicuously mark port plate (47, figure 8-3) and cam ring (49) to insure that they will be installed properly.

#### NOTE

It is not necessary to completely disassemble the heater assembly to replace a single part. Only those parts requiring repair or replacement need be removed.

c. Cleaning, Inspection, and Repair.

(1) Clean all electrical parts with filtered compressed air and a soft bristle brush. If necessary, remove caked deposits with an approved cleaning solvent. Do not dip electrical parts in cleaning water.

(2) Clean all non-electrical parts with dry cleaning solvent (Federal Specification P-D-680) and dry thoroughly.

(3) Inspect receptacle assembly for cracks, burned or damaged insulation, loose connections and bent or broken terminals. Check for continuity between wires and terminal pins with an ohmmeter.

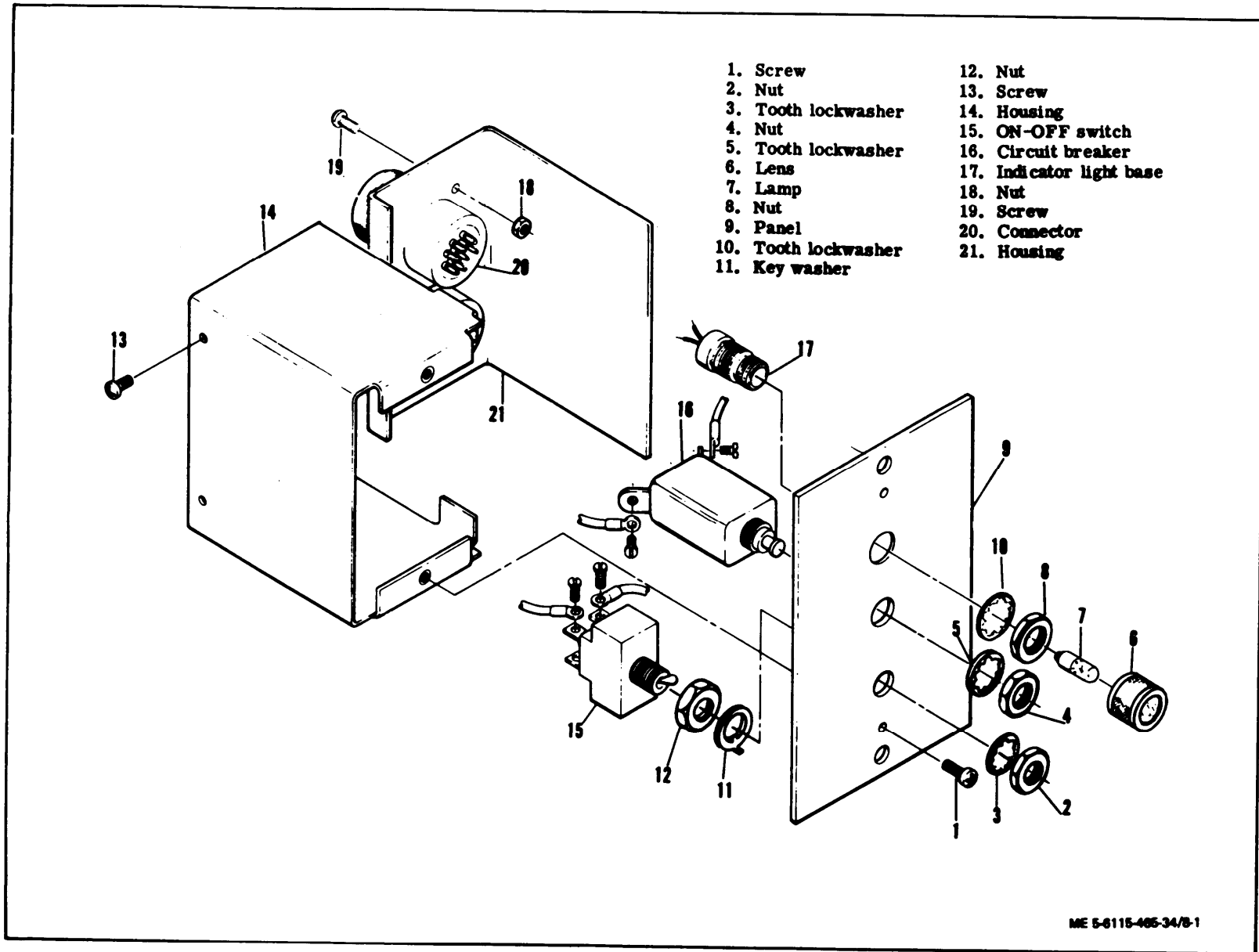
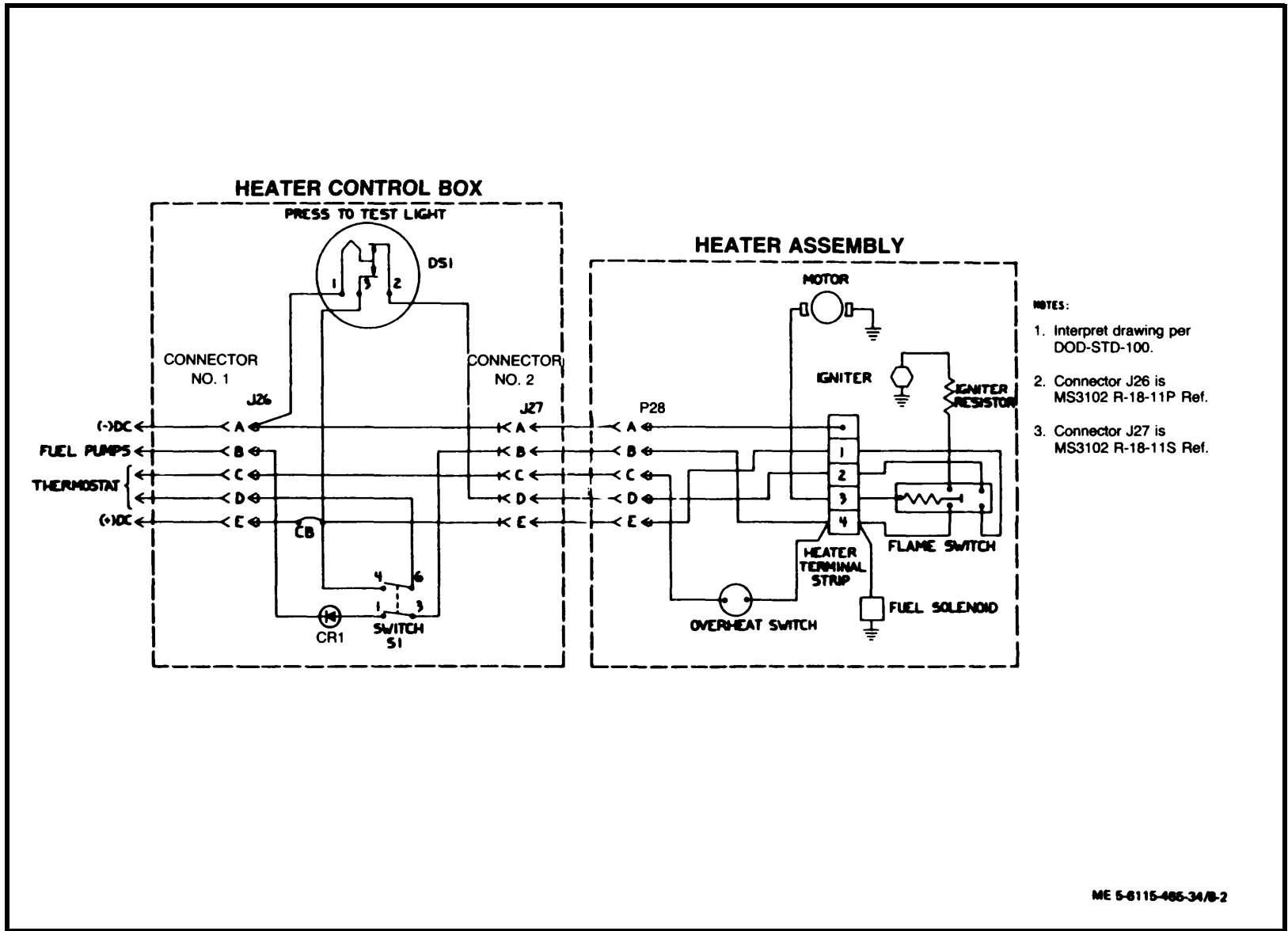

Figure 8-1. Fuel Burning Heater Control Assembly



Change 6

8-5

Figure 8-2. Fuel Burning Heater Control Assembly Wiring Diagram, Drawing No. 72-2863

ME 5-8115-466-34/B-2

TM 5-8115-466-34  
 TO 35C2-3-446-2  
 NAVFAC P-8-625-34  
 TLM 06859B/06859D-34

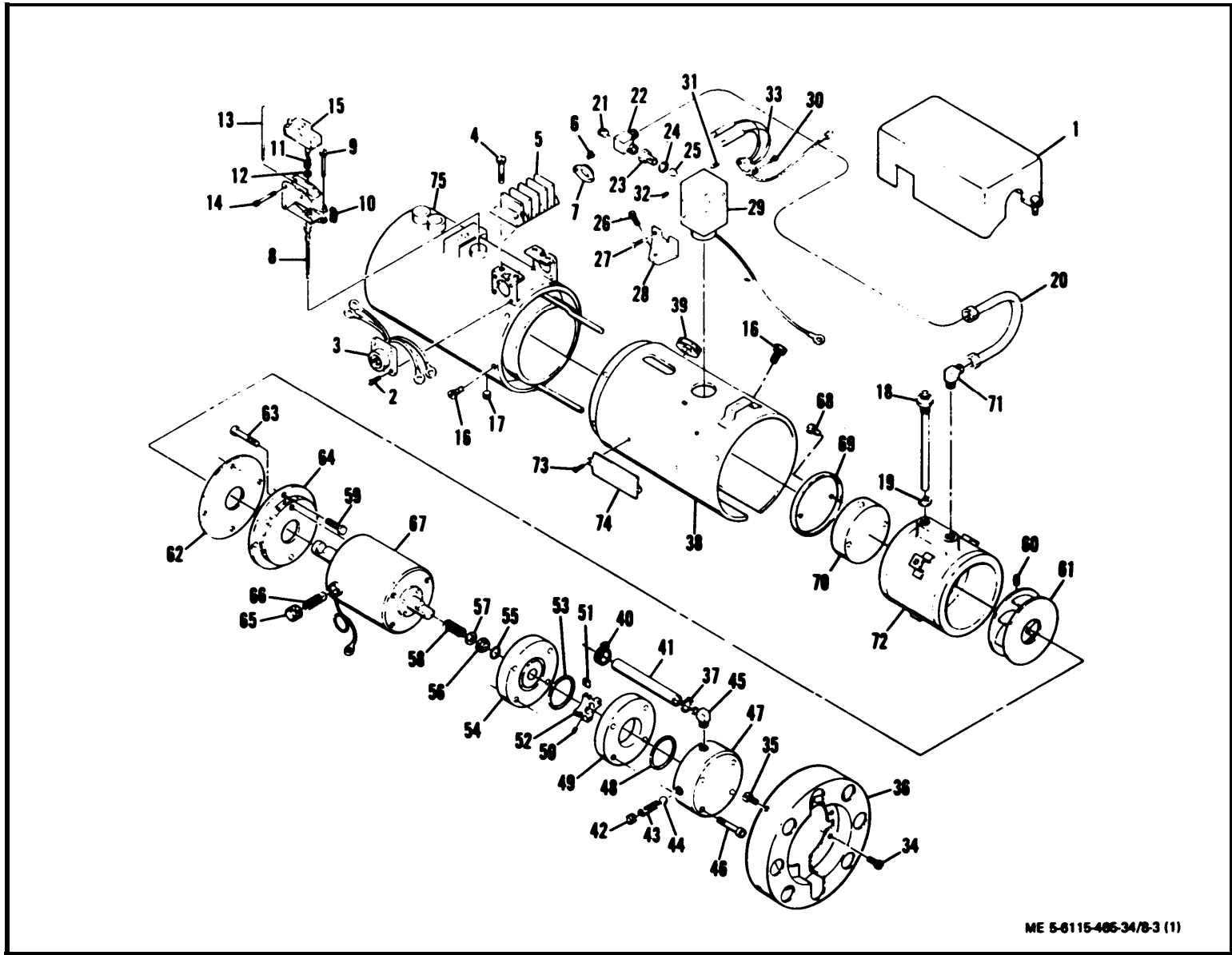

TM 5-6115-465-34  
TO 35C2-3-446-2  
NAVFAC P-8-625-34  
TM 06858B/06859D-34

Figure 8-3. Fuel Burning Heater Assembly, Exploded View (Sheet 1 of 2)



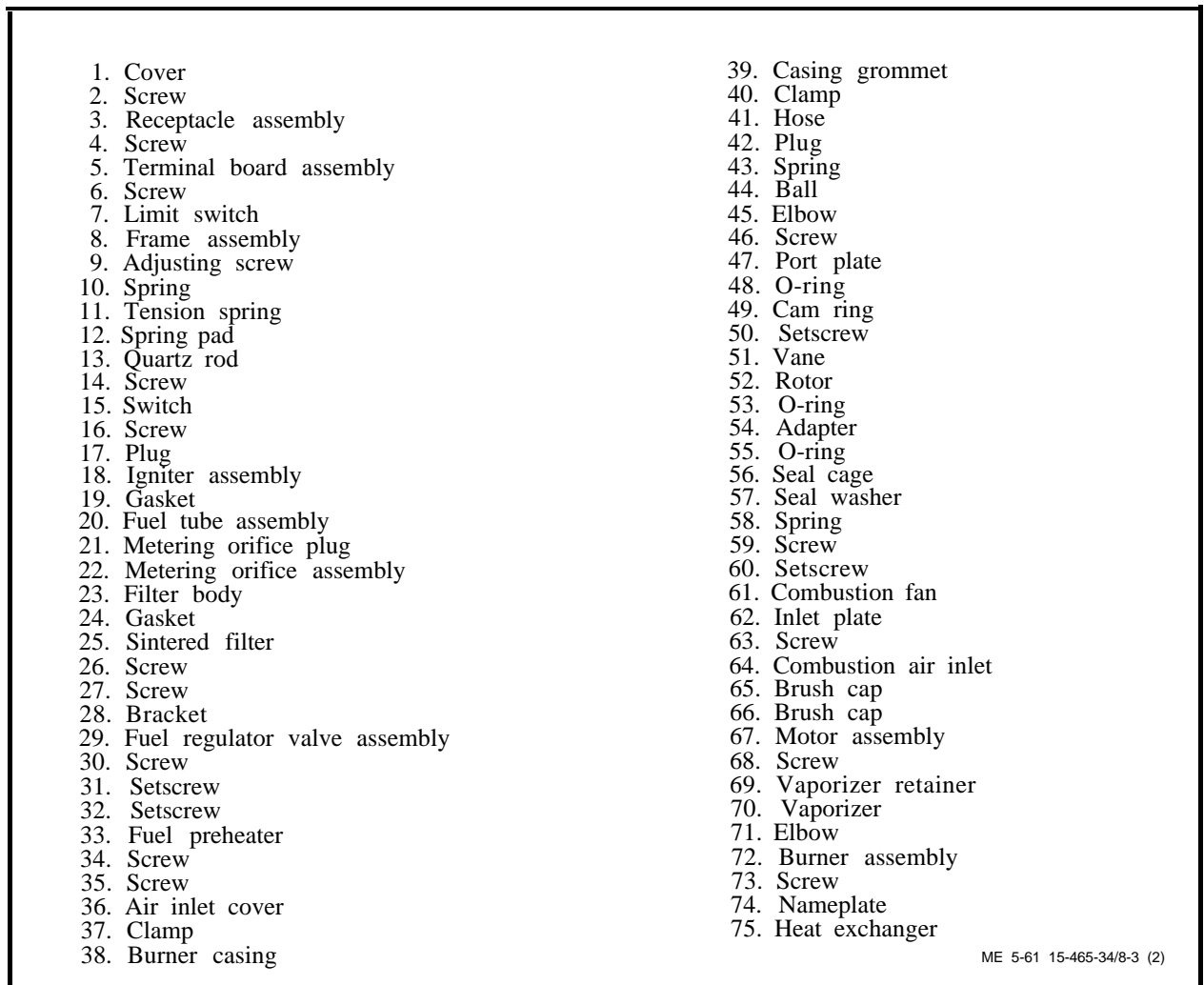

ME 5-61 15-465-34/8-3 (2)

Figure 8-3. Fuel Burning Heater Assembly, Exploded View (Sheet 2 of 2)

(4) Inspect fuel tube for cracks and other damage.

(5) Inspect metering orifice for damaged threads and obstruction at pin holes. Pin hole diameter is 0.012 inch.

(6) Inspect regulator valve for cracks, leaks, or damaged threads.

(7) Check flame switch for distorted or broken springs, loose pivot points, stripped threads, and cracked or damaged insulation. Check flame switch for continuity.

(8) Inspect igniter for a broken coil or shorts. Check resistance. Resistance must be one ohm with igniter cold.

(9) Inspect quartz rod and heat exchanger for damage, warping, or burned condition.

(10) Inspect air inlet cover for dents. Inspect blower casting for damaged blades, cracks, and breaks.

(11) Inspect heater casting for defective threads, or burned or damaged condition.

(12) Inspect sintered filter for clogged or damaged condition.

(13) Inspect motor assembly for damaged threads, burned or frayed leads and worn brushes.

(14) Inspect adapter for damaged or scored face, warping and for motor shaft bore wear. Face of

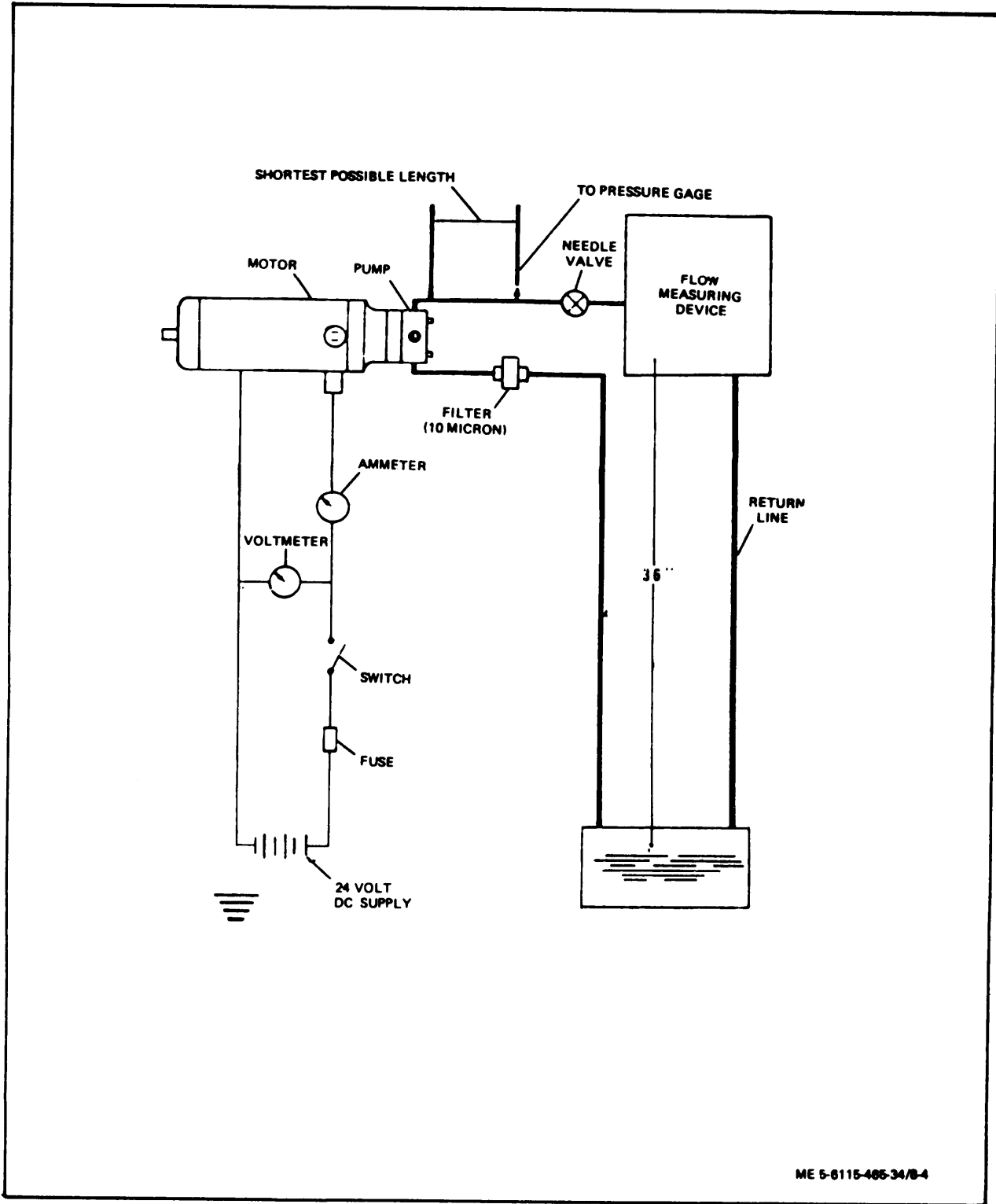

Figure 8-4. Coolant Pump Test Diagram

adapter must be parallel within 0.001 inch. Adapter bore diameter must be 0.315 to 0.318 inch. Adapter face must be parallel with rotor side of adapter within 0.001 inch per inch.

(15) Inspect rotor and rotor blades for nicks, scratches and excessive wear.

(16) Inspect seal cage for scored or damaged face and for wear. Remove all imperfections by lapping, or replace seal cage.

(17) Inspect cam ring and port plate for damaged, scored, or warping. Replace defective cam ring or port plate.

(18) Replace all gaskets, seal rings, motor brushes and vaporizer at each overhaul.

(19) Replace all parts that do not meet inspection requirements.

(20) Seal faces of adapter and seal cage may be dressed to remove minor nicks, scratches or scoring using crocus cloth (Federal specification P-C-458). Remove only material necessary to clean seal face.

d. Assembly. Assemble the fuel burning heater assembly in reverse order of disassembly procedures while observing the following:

(1) Exercise care in replacing quartz rod (13, figure 8-3) as it is easily broken if dropped. After installation, gently move rod up and down to make sure it moves freely in its stainless steel tube. Also make sure at least 1/32 inch extends out of tube when rod is resting on bottom.

(2) Assemble motor assembly (67), combustion air inlet (64), inlet plate (62) and combustion fan (61) before installing burner assembly.

(3) Make sure lead wire from motor assembly is on side of blower opposite nameplate (74) before drawing it through casing grommet (39).

(4) Make sure all wire leads are connected to their respective terminals as tagged during disassembly.

#### NOTE

Coolant pump can not be assembled completely and installed as a separate unit. It must be assembled as it is installed on short shaft end of motor. Test motor and pump (paragraph e. (3) before completing heater assembly.

(5) Install seal spring (58) and seal washer (57) over end of motor shaft. Place o-ring (55) in seal cage (56), then install seal cage over end of motor shaft with seal face facing forward.

(6) Install adapter (54) over motor shaft and align holes with tapped holes in motor.

(7) Install pump rotor (52) on motor shaft and temporarily tighten rotor setscrew (50). Place o-ring (53) in groove of adapter (54). Place cam ring in position aligning scribe mark. With motor shaft end play taken up in direction of pump, make certain there is at least 0.002-inch clearance between outer face of cam ring and rotor. Move rotor back and forth as necessary to produce this clearance, then tighten setscrew.

#### NOTE

Make sure that adapter and cam ring are tightly compressed together when determining 0.002 inch clearance, otherwise, a false reading will be obtained.

(8) Install pump vane (51) in rotor slots making sure that grooves in vanes face toward the direction of rotation. Pump rotates counterclockwise when viewing end of port plate (47).

(9) Place o-ring (48) in groove of port plate (47), then position plate against cam ring (49). Align scribe marks and secure with four setscrews (46).

(10) Test heater assembly. Plug threaded ports with caps if pump is not to be assembled in heater immediately.

#### e. Testing and Adjustment.

(1) Flame Switch Adjustment. Refer to the Operator and Organizational Maintenance Manual for flame switch adjustment procedures.

(2) Fuel Regulator Valve Adjustment. Refer to the Operator and Organizational Maintenance Manual for fuel regulator valve adjustment procedures.

(3) Coolant Pump Testing. After coolant pump has been overhauled, it shall be tested as follows :

(a) Install pump and motor assembly into test setup shown in figure 8-4.

(b) Turn power switch ON and run-in unit for approximately 15 minutes on 24 volts dc.

(c) Close valve in outlet line. (Make certain the discharge pressure does not exceed a maximum of 30-35 psi when closing this valve. ) Open and close valve a few times to check consistency of valve performance.

(d) To check pump for rated flow and pressure, adjust valve in discharge line until a reading of 2 psi is obtained on the pressure gauge. Using a suitable timer, check for rated flow of 80 gph minimum at 2 psi discharge pressure. Amperage draw should

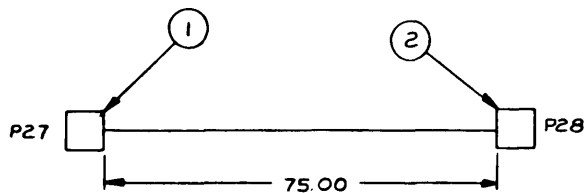

## NOTES:

1. ALL SOLDERED CONNECTIONS SHALL BE IN ACCORDANCE WITH MIL-STD-454, REQUIREMENT 5.
2. INSTALL STRAPS, FIND NO. 5, AT 3.0 MAX INTERVALS AND AT EACH CABLE BREAK-OUT.
3. WIRE MARKING TO BE IN ACCORDANCE WITH MIL-W-5000 EXCEPT THAT LENGTH BETWEEN GROUPS OF NUMBERS SHALL NOT EXCEED 6 INCHES
4. INTERPRET DRAWING PER MIL-STD-100.

## 5. REFERENCES

- a) FOR WIRING DIAGRAM, SEE DRAWING 72-2205.
- b) FOR SCHEMATIC DIAGRAM, SEE DRAWING 72-2200.

WIRE MARKING	WIRE RIMMING LIST				WIRE FIND NO. REF	WIRE LENGTH REF	WIRE MARKING COLOR
	FROM	FIND NO. REF	TO	FIND NO. REF			
P55GR16	P27-A	1	P20-A	2	3	76.00	RED
P70R16	P27-B	1	P20-B	2	3	76.00	RED
P64G12	P27-C	1	P20-C	2	4	76.00	RED
P82R12	P27-D	1	P20-D	2	4	76.00	RED
P83R12	P27-E	1	P20-E	2	4	76.00	RED

5			MS3367-4-5	AR	STRAP, CABLE ADJUSTABLE			
4			MS086/2-12-9	AR	WIRE ELECTRICAL 12 AWG	MIL-W-5006/2		
3			MS086/2-16-9	AR	WIRE ELECTRICAL 16 AWG	MIL-W-5006/2		
2			MS3106R10-115	:	CONNECTOR ELECTRICAL P20			
1			MS3106R10-11P	1	CONNECTOR ELECTRICAL P27			
FIND NO	SYN	CODE IDENT	DWG SIZE	QTY REQD	PART OR IDENTIFYING NO	NOMENCLATURE OR DESCRIPTION	SPECIFICATION	MATERIAL

## LIST OF MATERIAL

ME 5-6115-485-34/B-5

TM 5-6115-485-34  
 TO 35C2-3-446-2  
 NAVFAC P-8-625-34  
 TLM 06858B/06859D-34

Figure 8-5. Fuel Burning Winterization Kit Wiring Harness, Drawing No. 72-2856

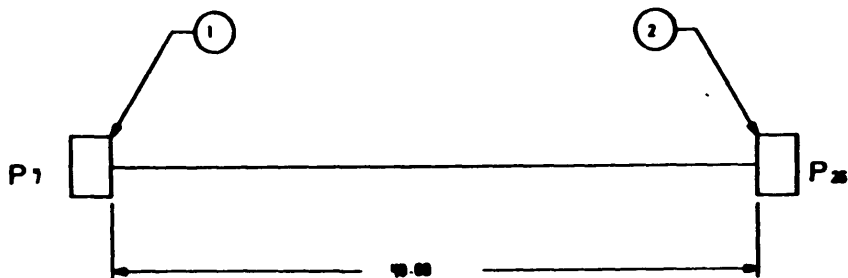

**NOTES:**

1. ALL SOLDERED CONNECTIONS SHALL BE IN ACCORDANCE WITH MIL-STD-454, REQUIREMENT
2. INSTALL STRAPS, FIND NO. 5, AT 3.0 MAX INTERVALS
3. WIRE BUNDLING TO BE IN ACCORDANCE WITH MIL-W-5000 EXCEPT THAT LENGTH BETWEEN GROUPS OF BUNDLES SHALL NOT EXCEED 6 INCHES.
4. REFERENCES:  
 a) FOR WIRING DIAGRAM, SEE DRAWING 72-2205.  
 b) FOR SCHEMATIC DIAGRAM, SEE DRAWING 72-2200.
5. INTERPRET DRAWINGS PER DOD-STD-100.



WIRE BUNDLING	TERMINATION		TERMINATION		WIRE FIND NO REF	WIRE LENGTH REF	WIRING COLOR
	FROM	FIND NO REF	TO	FIND NO REF			
P26C12	P7-A	1	P26-A	2	3	41.50	RED
P51C16	P7-B	1	P26-B	2	4	↑	↑
W40A12	P7-C	1	P26-C	2	5	↑	↑
W45A12	P7-B	1	P26-B	2	3	↑	↑
P141612	P7-E	1	P26-E	2	4	41.50	RED

FIND NO	CODE	PLG	PART OR IDENTIFYING NO	QTY	TERMINATION OR DESCRIPTION	SPECIFICATION	MATERIAL
5			MS3047-0-9	08	STRAP CABLE ADJUSTABLE		
4			MS3006/2-16-9	08	WIRE ELECTRICAL 160MS	MIL-W-5006/2	
3			MS3006/2-12-9	08	WIRE ELECTRICAL 120MS	MIL-W-5006/2	
2			MS3100A10-115	1	CONNECTOR PLUG ELECTRICAL, P26		
1			MS3100A10-11P	1	CONNECTOR PLUG ELECTRICAL, P7		



ME 5-6115-405-34/0-0

TM 5-6115-405-34  
 TO SSC2-3-446-3  
 NAVFAC P-0-025-94  
 TMM 06658B/06659D-34

Figure 8-6. Fuel Burning Winterization Heater Control Assembly to Special Relay Assembly Wiring Harness  
 Drawing No. 72-2875

not exceed 6 amperes during this test. Observe smoothness of operation of both pump and motor. Seal leakage of 1 cc per hour is maximum when pump is operating at 2 psi discharge.

(e) Turn power supply OFF, then remove motor and pump assembly from test setup.

f. Installation. Refer to the Operator and Organizational Maintenance Manual for fuel burning heater installation procedures.

8-5. COOLANT LINES AND FITTINGS.

Refer to the Operator and Organizational Maintenance Manual for coolant lines and fittings repair instructions.

8-6. WIRING HARNESS ASSEMBLIES.

a. Refer to the Operator and Organizational Maintenance Manual for wiring harness removal, cleaning, and repair instructions.

b. If the wiring harnesses have sustained damage and require repair or rebuild refer to figure 8-5 or 8-6 as required for layout, identification of material requirements and Appendix A reference for detailed soldering and replacement procedures.

c. Refer to the Operator and Organizational Maintenance Manual for wiring harness installation procedures.

Section II ELECTRIC WINTERIZATION KIT

8-7. GENERAL.

The electric winterization kit is used to maintain the engine coolant and lubricating oil at normal operating temperature in situations which require immediate starting of the generator set. It will function effectively down to an ambient temperature of -65°F (-53. 9°C). The kit consists of a heater assembly, a heater control assembly, and interconnecting coolant lines and fittings and wiring harnesses. Power for operation of the kit may be obtained from any 208 to 240 volt, 50/60 Hz or 400 Hz, single phase source.

8-8. TROUBLESHOOTING.

Table 8-2 contains a numerical list of malfunctions which is useful in diagnosing and correcting unsatisfactory operation or failure of the electric winterization kit. Each numbered malfunction is followed by an alphabetical listing of probable causes of the malfunction. The corresponding alphabetical listing of corrective actions contains references to the applicable maintenance paragraphs for correcting the cause of the malfunction

NOTE

Refer to the Operator and Organizational Maintenance Manual for troubleshooting information applicable to lower levels of maintenance.

Table 8-2. ELECTRIC WINTERIZATION KIT TROUBLESHOOTING CHART

MALFUNCTION	PROBABLE CAUSE	CORRECTIVE ACTION
1. HEATER ON indicator light does not illuminate with switch in ON position	a. Defective fuse. b. Defective switch. c. Defective circuit breaker. d. Defective lamp. e. Defective semi-conductor. f. Defective transformer.	a. Replace fuse (para. 8-9). b. Replace switch (para. 8-9). c. Replace circuit breaker (para. 8-9). d. Replace lamp (para. 8-9). e. Replace semiconductors (para. 8-9). f. Replace transformer (para. 8-9).
2. POWER ON indicator light does not illuminate with switch in ON position.	a. See Malfunction 1 of this table. b. Defective thermostat.	a. See Malfunction 1 of this table. b. Replace thermostat (para. 8-10).

Table 8-2. ELECTRIC WINTERIZATION KIT TROUBLESHOOTING CHART (CONT)

MALFUNCTION	PROBABLE CAUSE	CORRECTIVE ACTION
3. Heater element does not heat up	a. Defective wiring harness. b. Defective heater element. c. Defective power relay.	a. Replace wiring harness (para. 8-13). b. Replace heater element (para. 8-10). c. Replace power relay (para. 8-9).
4. Pump does not circulate coolant	a. Defective fuse. b. Defective switch. c. Defective circuit breaker. d. Defective semiconductor. e. Defective motor assembly. f. Defective pump.	a. Replace fuse (para. 8-9). b. Replace switch (para. 8-9). c. Replace circuit breaker (para. 8-9). d. Replace semiconductor (para. 8-9). e. Replace motor assembly (para. 8-11). f. Repair or replace pump (para. 8-11).

8-9. HEATER CONTROL ASSEMBLY.

a. Removal. Refer to the Operator and Organizational Maintenance Manual for heater control assembly removal instructions.

b. Disassembly. Disassemble heater control assembly by following the ascending sequence of index numbers (1 through 60) assigned to figure 8-7 while observing the following:

(1) Tag all electrical leads before disconnecting.

(2) Disassemble heater control assembly only as required to clean, inspect, test and replace components.

c. Cleaning, Inspection, and Repair.

(1) Clean all electrical parts with filtered compressed air and a soft bristle brush. If necessary, caked deposits may be removed with a clean, lint-free cloth moistened with an approved solvent. Do not dip electrical parts in cleaning solvent.

(2) Clean non-electrical parts with a clean, lint-free cloth moistened with dry cleaning solvent (P-D-680) and dry thoroughly.

(3) Visually inspect switch for cracked casing, corrosion, and burns or other evidence of shorting. Check switch continuity.

(4) Inspect circuit breaker for cracked casing, corrosion, and burns or other evidence of

shorting. Check circuit breaker continuity using an ohmmeter. Replace circuit breaker if defective.

(5) Inspect fuse holder for cracks, corrosion, stripped threads and burns or other evidence of shorting. Replace if defects are noted.

(6) Inspect indicator light for cracked or broken lens, damaged or defective lamp, cracks, corrosion, and burns. Replace any defective parts.

(7) Inspect power relay for cracks, corrosion, and burns or other evidence of shorting. Using an ohmmeter, check power relay coil resistance. Resistance shall be 30-45 ohms at 77°F (25°C). Replace power relay if damaged or defective.

(8) Inspect transformer for corrosion, cracks, and burns or other evidence of overheating.

(9) Using figure 8-8 as a guide, test transformer as follows:

(a) Using an ohmmeter, check resistance of windings. Winding 1-2 shall indicate  $6.77 \pm 0.677$  ohms. Winding 3-5 shall indicate  $0.108 \pm 0.0108$  ohm.

(b) Apply 230 Vac, RMS to winding 1-2 with all secondaries open circuit. Exciting current shall be less than 0.04 amps RMS (0.01 amp RMS for 400 Hz).

(c) Apply 253 Vac RMS to winding 1-2 with all secondaries open circuit. Exciting current shall be less than 0.065 amp RMS (0.016 amp for 400 Hz).

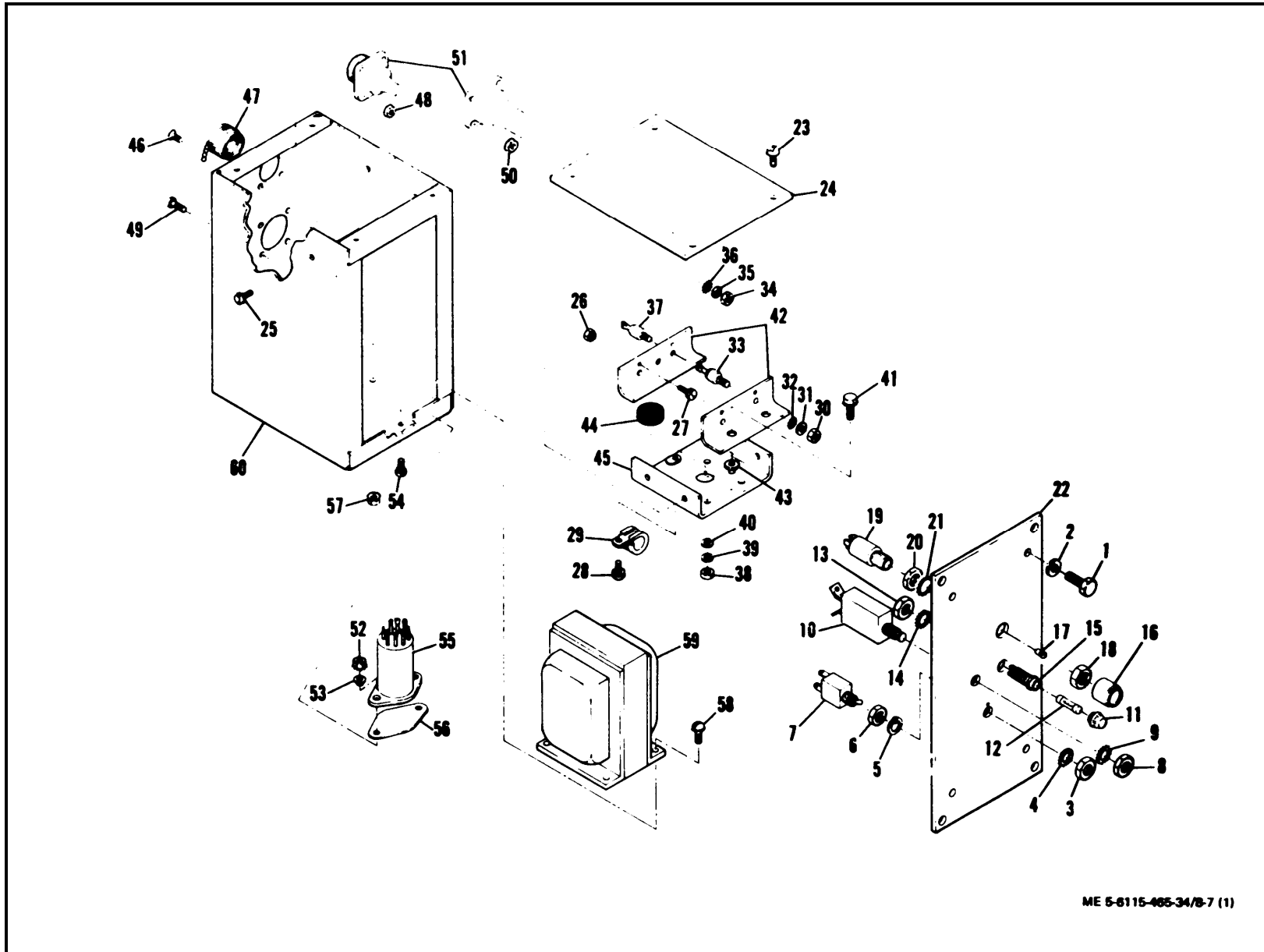

TM 5-6115-465-34  
TO 35C2-3-446-2  
NAVFAC P-8-635-34  
TM 06859B/06859D-34

Figure 8-7. Electric Winterization Kit Heater Control Assembly, Exploded View (Sheet 1 of 2)



- |                                     |                                     |
|-------------------------------------|-------------------------------------|
| 1. Screw                            | 31. Flat washer                     |
| 2. Lockwasher                       | 32. Tooth lockwasher                |
| 3. Nut                              | 33. Semiconductor                   |
| 4. Tooth lockwasher                 | 34. Nut                             |
| 5. Positioning washer               | 35. Flat washer                     |
| 6. Nut                              | 36. Lockwasher                      |
| 7. Switch                           | 37. Semiconductor                   |
| 8. Nut                              | 38. Nut                             |
| 9. Tooth lockwasher                 | 39. Flat washer                     |
| 10. Circuit breaker                 | 40. Shoulder washer                 |
| 11. Fuseholder cap                  | 41. Screw & captive washer assembly |
| 12. Fuse                            | 42. Heat sink                       |
| 13. Nut                             | 43. Shoulder washer                 |
| 14. Tooth lockwasher                | 44. Split grommet                   |
| 15. Fuseholder                      | 45. Heat sink bracket               |
| 16. Lens                            | 46. Screw & captive washer assembly |
| 17. Lamp                            | 47. Protective cap and chain        |
| 18. Nut                             | 48. Nut                             |
| 19. Indicator light base            | 49. Screw & captive washer assembly |
| 20. Nut                             | 50. Nut                             |
| 21. Tooth lockwasher                | 51. Wiring harness                  |
| 22. Panel                           | 52. Nut                             |
| 23. Screw & captive washer assembly | 53. Shoulder washer                 |
| 24. Cover                           | 54. Screw                           |
| 25. Screw & captive washer assembly | 55. Power relay                     |
| 26. Nut & captive washer assembly   | 56. Relay insulator                 |
| 27. Screw & captive washer assembly | 57. Nut                             |
| 28. Screw & captive washer assembly | 58. Screw & captive washer assembly |
| 29. Cushion clamp                   | 59. Transformer                     |
| 30. Nut                             | 60. Chassis                         |

ME 5-6115-465-34/8-7 (2)

Figure 8-7. Electric Winterization Kit Heater Control Assembly, Exploded View (Sheet 2 of 2)

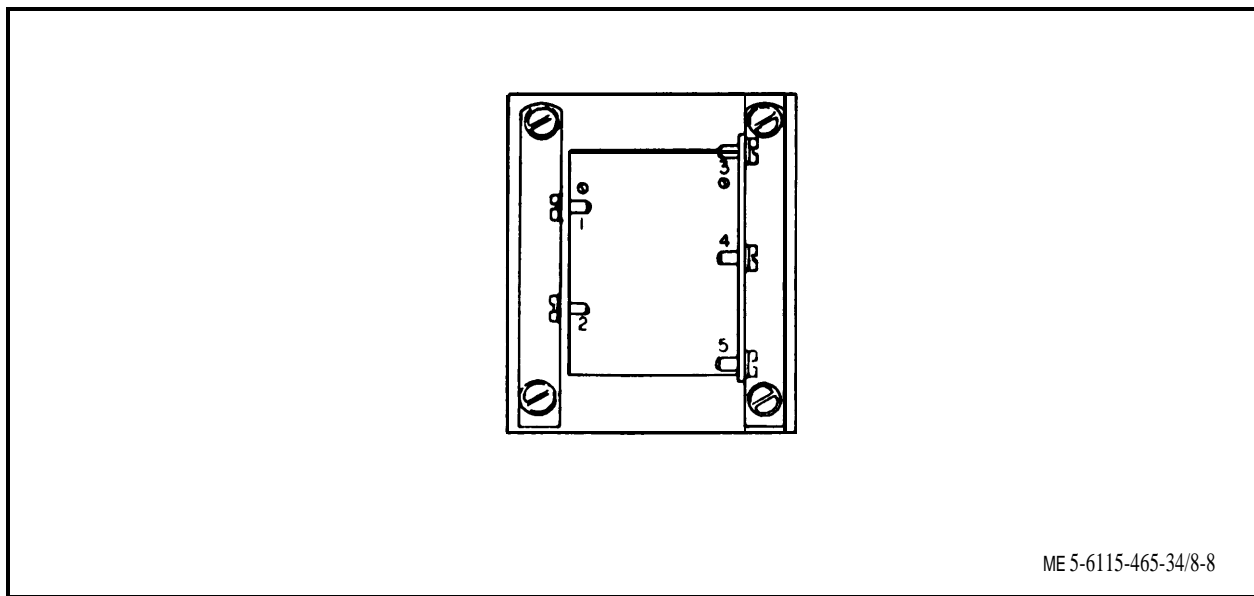

ME 5-6115-465-34/8-8

Figure 8-8. Transformer Test Points

(d) Apply 230 Vac RMS to winding 1-2 with all secondaries open circuit. Voltage across winding 3-4 shall be  $14.8 \pm 0.148$  volts RMS. Voltage across winding 3-5 shall be  $29.6 \pm 0.296$  volts RMS.

(e) Replace transformer if damaged or defective.

(10) Use a semiconductor test set to check semiconductors for inverse current leakage at peak recurrent inverse voltage of 600 volts. Leakage shall not exceed 20.0 milliamperes at 77°F (25°C). Check forward voltage drop. Voltage drop shall not exceed 1.2 volts at 77°F (25°C). Replace defective semiconductors.

(11) Inspect heat sink and bracket for cracks, corrosion and evidence of overheating.

(12) Inspect wiring harness for loose or damaged connector pins, damaged terminals, worn or chafed insulation, and burned areas indicating shorting. Check individual wires for continuity using figure 8-9 as a guide.

(13) If the wiring harness has sustained damage and requires repair or rebuild, refer to figure 8-9 for layout, identification of material requirements and Appendix A references for detailed soldering and replacement procedures.

(14) Inspect chassis and cover for cracks, corrosion, warping and other damage. Replace parts damaged beyond repair.

(15) Inspect hardware for crossed, stripped, and peened threads.

d. Assembly. Assemble heater control assembly in reverse order of removal procedures.

e. Installation. Refer to the Operator and Organizational Maintenance Manual for electric winterization kit heater control assembly installation instructions.

#### 8-10. HEATER ASSEMBLY.

Refer to the Operator and Organizational Maintenance Manual for electric winterization kit heater assembly maintenance instructions.

#### 8-11. COOLANT PUMP AND MOTOR ASSEMBLY.

a. Removal. Refer to the Operator and Organizational Maintenance Manual for coolant pump and motor assembly removal procedures.

b. Disassembly. Disassemble coolant pump and motor assembly by following the sequence of index numbers 1 through 21 assigned to figure 8-10.

#### NOTE

Conspicuously mark port plate (5) and cam ring (9) to insure that they will be installed properly.

c. Cleaning, Inspection, and Repair.

(1) Clean motor assembly with a clean lint-free cloth moistened with an approved solvent.

(2) Wash all parts in dry cleaning solvent (Federal Specification P-D-680) and dry thoroughly.

(3) Inspect and repair pump parts as outlined in paragraph 8-4c. (15) through c. (20).

d. Assembly. Assemble coolant pump and motor assembly procedures while observing the following:

(1) Install seal spring (16) and seal washer (15) over end of motor shaft. Place o-ring (13) in seal cage (14), then install seal cage over end of motor shaft with seal face facing forward.

(2) Install adapter (12) over motor shaft and align holes with tapped holes in motor.

(3) Install pump rotor (10) on motor shaft and temporarily tighten rotor setscrew (8). Place cam ring (7) in position aligning scribe marks.

(4) With motor shaft end play taken up in direction of pump, make certain there is at least 0.002 inch clearances between outer face of cam ring and rotor. Loosen setscrew and position rotor if necessary. Remove cam ring.

(5) Install pump vanes (9) into rotor making sure that the grooves in the vane face the direction of rotation.

#### NOTE

Pump rotates counterclockwise when viewed from the port plate end.

(6) Place o-ring (6) into groove of port plate (5), then position port plate against cam ring (7). Align scribe marks and secure with screws (4).

(7) Install ball (3), spring (2), and plug (1).

e. Testing. Test coolant pump and motor assembly as directed in paragraph 8-4(e)(3).

#### 8-12. COOLANT LINES AND FITTINGS.

Refer to the Operator and Organizational Maintenance Manual for electric winterization kit coolant lines and fittings maintenance instructions.

WIRE NO.	SIZE REF.	LENGTH REF.	COLOR	FROM	END PREP PREP	TO	END PREP
X9EA12C	12	21.00	BLK MKG.	J49-A	SOLDER	CB301-A	(5)
X10EA10C	16	20.50		CB301-B	(4)	K301-A2	SOLDER
X10EB10C		7.50		CB301-B	(4)	S301-1	(3)
X11EA10C	16	10.00		J19-L	SOLDER	K301-A1	SOLDER
X12EA12N	12	14.50		J49-B	SOLDER	S301-8	(13)
X13EB10N	16	13.50		J19-B		S301-7	(3)
X14EB10C	16	18.50		J19-M	SOLDER	S301-2	(3)
X14EA10C	16	8.50		S301-2	(3)	F301	SOLDER
X301A16		12.50		T301-3	(4)	CR301	SOLDER
X302A16		14.50		T301-5	(4)	CR304	SOLDER
P90A16		13.50		J19-J	SOLDER	E301	(3)
P90C16		24.50		E302	(3)	DS302-1	SOLDER
P90D16		18.80		E303	(3)	S301-5	(3)
P91A16		12.50		J19-K	SOLDER	E304	(3)
P91C16		13.00		DS302-2	SOLDER	S301-3	(3)
P91D16		25.50		DS301-3	SOLDER	E306	(3)
P91E16		25.50		E305	(3)	DS302-3	SOLDER
P91F16		19.50		E306	(3)	S301-3	(3)
P99B16		20.50		K301-X2	SOLDER	DS301-2	SOLDER
P99A16		12.00		S301-4	(3)	DS301-2	SOLDER
V84F16		13.50	J19-H	SOLDER	S301-6	(3)	
V85F16		10.00	J19-A	SOLDER	K301-X1	SOLDER	
V85G16	16	20.50	K301-X1	SOLDER	DS301-1	SOLDER	
X13EA10N	16	17.50	T301-2	(4)	S301-7	(3)	
X12EB10N	16	21.50	BLK MKG	K301-B2	S301-8	(3)	
X15EA10N	16	11.00	BLK MKG	K301-B1	J19-C	SOLDER	
X16EA10C	16	20.50	BLK MKG	F301	SOLDER	T301-1	(4)

ME 5-6115-465-34/8-9(1)

Figure 8-9. Electric Winterization Kit Heater Control Assembly, Wiring Harness (Sheet 1 of 2), Drawing No. 70-1233

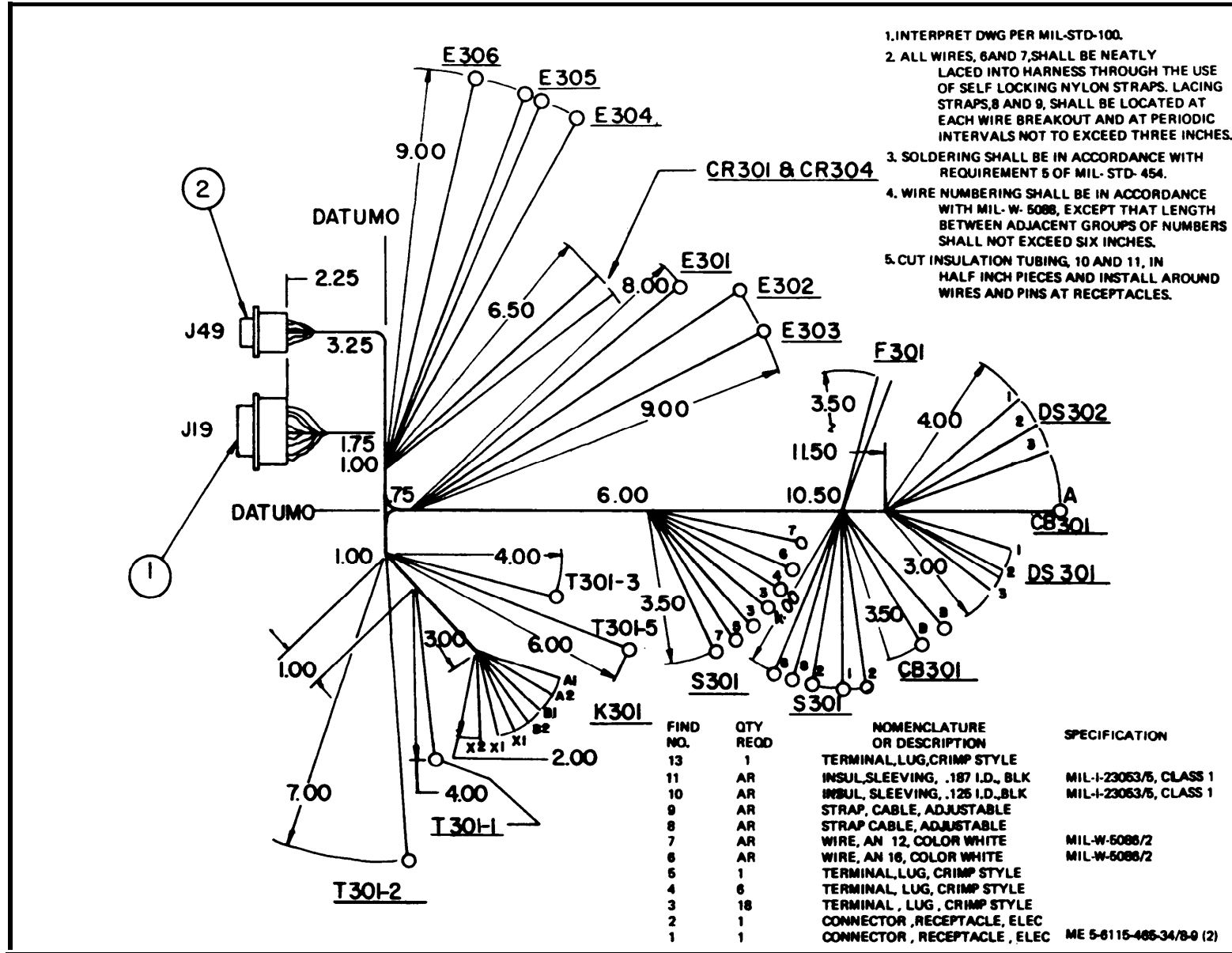

TM 5-6115-465-34  
 TO 35C2-3-446-2  
 NAVFAC P-8-825-34  
 TM 06858B/06859D-34

Figure 8-9. Electric Winterization Kit Heater Control Assembly Wiring Harness (Sheet 2 of 2), Dwg. 70-1233.

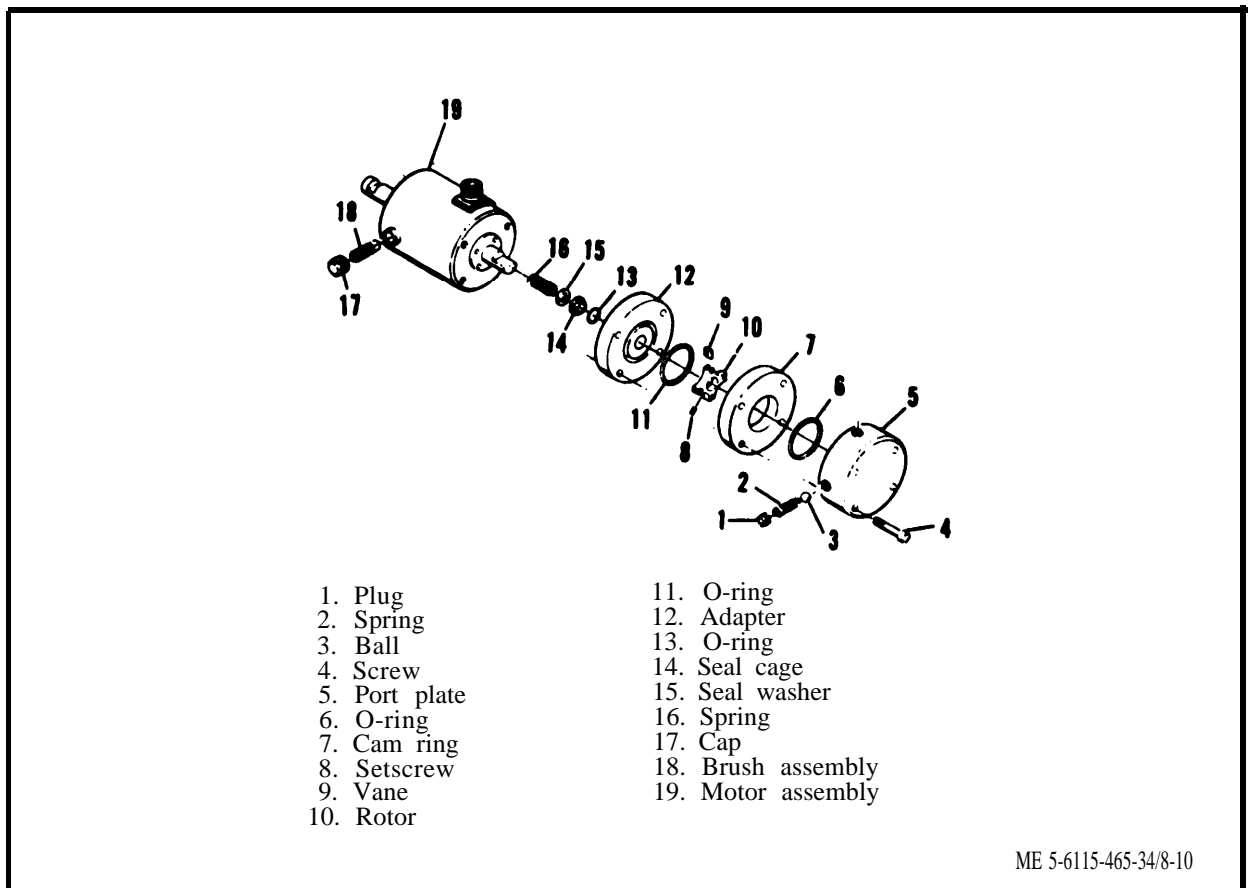

Figure 8-10. Coolant Pump and Motor Assembly, Exploded View

8-13. WIRING HARNESS.

a. Refer to the Operator and Organizational Maintenance Manual for wiring harness removal, cleaning, inspection, and repair procedures.

b. If the wiring harness has sustained damage and requires repair or rebuild, refer to figure 8-11

for layout, identification of material requirements and Appendix A reference for detailed soldering and replacement procedures.

c. Refer to Operator and Organizational Maintenance Manual for wiring harness installation procedures.

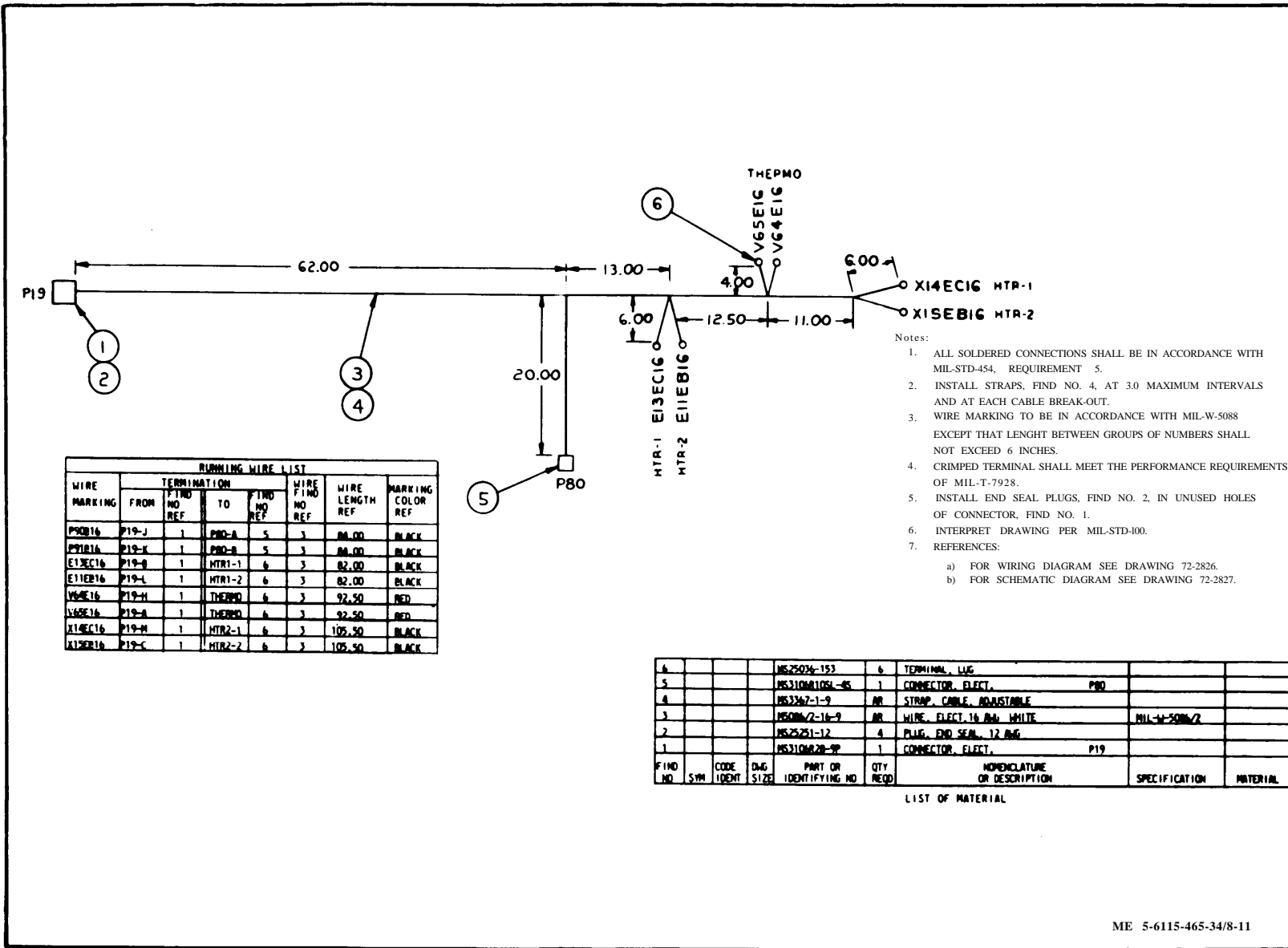

RUNNING WIRE LIST							
WIRE MARKING	TERMINATION		WIRE FIND NO REF	WIRE LENGTH REF	MARKING COLOR REF		
	FROM FIND NO REF	TO FIND NO REF					
P90B16	P19-J	1	P80-A	5	3	88.00	BLACK
P91B16	P19-K	1	P80-B	5	3	88.00	BLACK
E13EC16	P19-Q	1	HTR1-1	6	3	82.00	BLACK
E11EB16	P19-L	1	HTR1-2	6	3	82.00	BLACK
V65E16	P19-H	1	THERMO	6	3	92.50	RED
V66E16	P19-A	1	THERMO	6	3	92.50	RED
X14EC16	P19-H	1	HTR2-1	6	3	105.50	BLACK
X15EB16	P19-C	1	HTR2-2	6	3	105.50	BLACK

FIND NO	SYM	CODE IDENT	QTY REQD	DESCRIPTION	SPECIFICATION	MATERIAL
6			6	TERMINAL, LUG		
5			1	CONNECTOR, ELECT.	P80	
4			AR	STRAP, CABLE, ADJUSTABLE		
3			AR	WIRE, ELECT, 16 AWG, WHITE	MIL-W-5088/2	
2			4	PLUG, END SEAL, 12 AWG		
1			1	CONNECTOR, ELECT.	P19	

LIST OF MATERIAL

Figure 8-11. Electric Winterization Kit Wiring Harness, Drawing No. 72-2855

### Section III. WHEEL MOUNTING KIT

#### 8-14. GENERAL.

The wheel mounting kit provides added mobility for the generator set. It consists of a front and a rear axle assembly. The front axle assembly is equipped with a tow bar, pintle and safety chains. A lock holds the tow bar in the vertical position when not in use. A mechanical parking brake locks the wheels of the rear axle assembly against rotation. It is actuated by a hand lever located at the right rear of the generator set. The wheel mounting kit provides 8 inches of ground clearance for the generator set.

#### 8-15. WHEEL MOUNTING KIT INSTALLATION AND REMOVAL.

##### a. Installation.

#### WARNING

Do not use hoisting equipment with maximum capacity less than 5000 pounds. Do not allow generator set to swing while suspended.

#### CAUTION

Use a minimum bridle of 5 feet on the hoisting sling to avoid undue side pressure on the lifting frame.

(1) Using suitable hoisting equipment, raise the generator set sufficiently to clear axle assemblies.

(2) Position axle assemblies under generator set.

#### WARNING

Do not allow any part of the body to get under the generator set. Serious injury or death may result from failure to observe this warning.

(3) Lower the generator set until it is just touching axle assemblies.

(4) Install attaching hardware as shown in figure 8-12.

(5) Lower generator set until it is supported on the axle assemblies and remove hoisting equipment.

b. Removal. Remove wheel mounting kit in reverse order of installation procedures.

#### 8-16. WHEELS AND TIRES.

Refer to the Operator and Organizational Maintenance Manual for wheels and tires maintenance instructions and alignment procedures.

#### 8-17. WHEEL BEARINGS.

Refer to the Operator and Organizational Maintenance Manual for wheel bearing maintenance instructions.

#### 8-18. AXLE ASSEMBLIES.

a. Removal. Refer to paragraph 8-15 for axle assembly removal instructions.

b. Disassembly.

(1) Refer to the Operator and Organizational Maintenance Manual and remove the wheels, tires, brakes, and wheel bearings.

(2) Complete disassembly by following the ascending sequence of index numbers (1 through 102) assigned to figure 8-13.

#### NOTE

Disassemble wheel mounting kit only as necessary to replace defective parts.

c. Cleaning, Inspection, and Repair.

(1) Clean all parts in dry cleaning solvent (Federal Specification P-D-680) and dry thoroughly.

(2) Inspect axle, tow bar, cross shaft and tube for wear, corrosion, defective paint, and other damage.

(3) Inspect all moving parts for cracks, corrosion, and deep wear patterns. Replace any defective parts.

(4) Inspect safety chains for cracked or broken links. Repair damaged links by welding.

(5) Check all threads for crossing, stripping, and peening.

(6) Replace any damaged or defective parts.

(7) Refer to the Operator and Organizational Maintenance Manual for troubleshooting and inspection procedures to determine which parts need replacement.

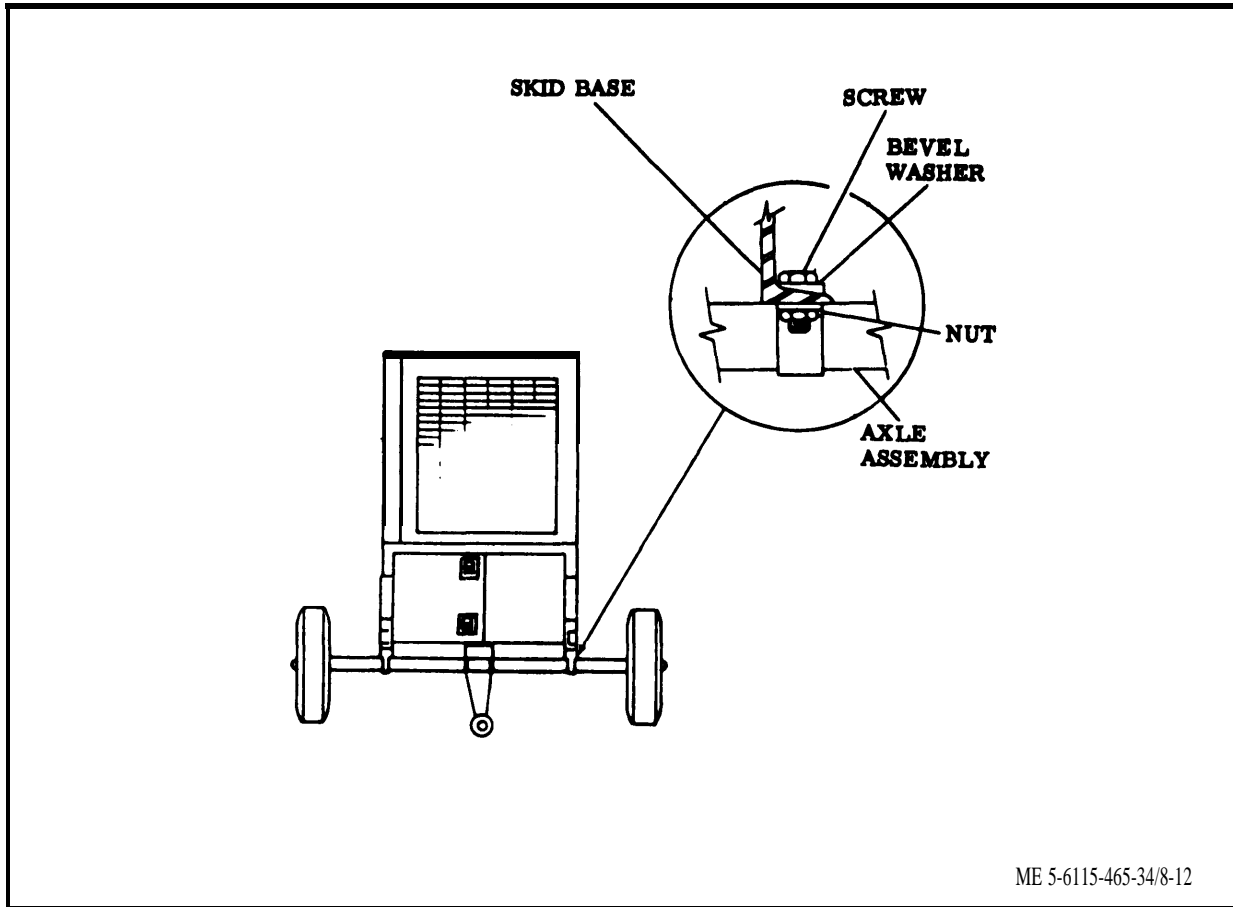

Figure 8-12. Wheel Mounting Kit Installation

**NOTE**

If king pins are excessively worn, perform the following procedures.

(8) Jack the front end of the generator up and place a suitable support under the front axle.

(9) Remove the grease cap (81, figure 8-13), cotter pin (82), castellated nut (83), key washer (84) and remove the wheel, tire, and hub as an assembly.

(10) Remove roll pin (52) and king pin (53).

(11) Install a new king pin and roll pin and install the wheel in reverse order of removal.

(12) Refer to Operator and Organizational Maintenance Manual and check wheel alignment.

d. Assembly. Assemble wheel mounting kit in reverse order of disassembly procedures.

e. Installation. Refer to paragraph 8-15 for wheel mounting kit installation procedures.



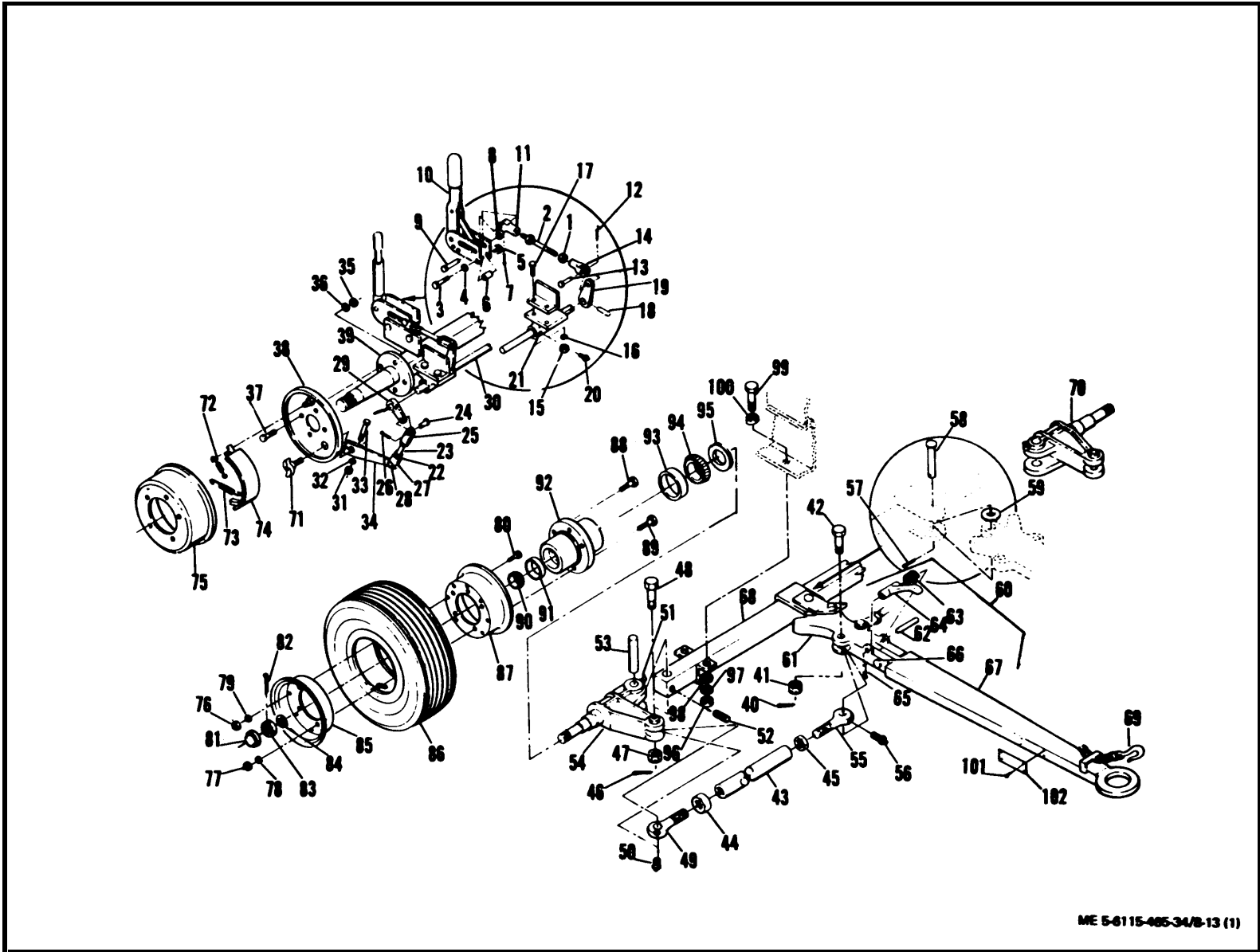

ME 5-6115-485-34/8-13 (1)

TM 5-6115-485-34  
 TO 35C3-3-446-2  
 NAVTRAC P-8-625-34  
 TM 06858B/06859D-34

Figure 8-13. Wheel Mounting Kit, Exploded View (Sheet 1 of 2)

- |                         |                       |
|-------------------------|-----------------------|
| 1. Nut                  | 52. Roll pin          |
| 2. Rod                  | 53. King pin          |
| 3. Bolt                 | 54. Spindle & knuckle |
| 4. Lockwasher           | 55. Tie rod end       |
| 5. Nut                  | 56. Grease fitting    |
| 6. Spacer               | 57. Cotter pin        |
| 7. Cotter pin           | 58. Pin               |
| 8. Washer               | 59. Spacer washer     |
| 9. Pin                  | 60. Tow bar           |
| 10. Hand lever assembly | 61. Center arm        |
| 11. Yoke                | 62. Roll pin          |
| 12. Cotter pin          | 63. Spring            |
| 13. Yoke pin            | 64. Latch             |
| 14. Yoke                | 65. Cotter pin        |
| 15. Nut                 | 66. Hinge pin         |
| 16. Lockwasher          | 67. Tow bar           |
| 17. Bolt                | 68. Front axle        |
| 18. Pin                 | 69. Safety chain      |
| 19. Lever               | 70. Spindle & knuckle |
| 20. Grease fitting      | 71. Camshaft          |
| 21. Bearing block       | 72. Hold-down spring  |
| 22. Nut                 | 73. Return spring     |
| 23. Rod                 | 74. Brake shoe        |
| 24. Pin                 | 75. Brake drum        |
| 25. Yoke                | 76. Nut               |
| 26. Pin                 | 77. Nut               |
| 27. Yoke                | 78. Lockwasher        |
| 28. Pin                 | 79. Lockwasher        |
| 29. Lever               | 80. Screw             |
| 30. Cross shaft         | 81. Grease cap        |
| 31. Nut                 | 82. Cotter pin        |
| 32. Lockwasher          | 83. Castellated nut   |
| 33. Bolt                | 84. Key washer        |
| 34. Lever               | 85. Wheel half        |
| 35. Nut                 | 86. Tire              |
| 36. Lockwasher          | 87. Wheel half        |
| 37. Bolt                | 88. Stud              |
| 38. Backing plate       | 89. Stud              |
| 39. Rear axle           | 90. Outer bearing     |
| 40. Cotter pin          | 91. Bearing race      |
| 41. Nut                 | 92. Hub               |
| 42. Bolt                | 93. Bearing race      |
| 43. Tube                | 94. Inner bearing     |
| 44. Nut                 | 95. Grease seal       |
| 45. Nut                 | 96. Nut               |
| 46. Cotter pin          | 97. Lockwasher        |
| 47. Nut                 | 98. Flat washer       |
| 48. Bolt                | 99. Capscrew          |
| 49. Tie rod end         | 100. Beveled washer   |
| 50. Grease fitting      | 101. Blind rivet      |
| 51. Grease fitting      | 102. ID plate         |

ME 5-6115-465-34/8-13 (2)

Figure 8-13. Wheel Mounting Kit, Exploded View (Sheet 2 of 2)

## Section IV. LOAD BANK

### 8-20. GENERAL.

The load bank is used to apply up to 50 percent of the generator rated load to prevent carbon buildup in the engine due to light loads. It is a balanced three phase, air cooled, resistive load which may be operated at either 120/208 or 240/416 volts. Generator load is selected through the load selector switch in increments of 12.5 percent rated generator load.

### 8-21. CONTROL BOX ASSEMBLY.

a. Removal. Refer to the Operator and Organizational Maintenance Manual for control box assembly removal procedures.

b. Disassembly.

(1) Remove load selector switch, circuit breaker, and indicator light as instructed in the Operator and Organizational Maintenance Manual.

(2) Complete disassembly of control box assembly by following the ascending sequence of index numbers (1 through 22) assigned to figure 8-14.

c. Cleaning, Inspection, and Repair.

(1) Clean all electrical parts with filtered compressed air and a soft bristle brush. If necessary, remove caked deposits with a clean, lint-free cloth moistened with an approved solvent.

(2) Clean chassis and back plate with dry cleaning solvent (Federal Specification P-D-680) and dry thoroughly.

(3) Inspect load sensing module for cracks, corroded terminals, and burns or other evidence of shorting.

(4) Inspect mode selector switch for cracks, corrosion and other damage. Check switch continuity using an ohmmeter.

(5) Inspect transformer for cracks, corrosion and burns or other evidence of shorting. Using an ohmmeter, check transformer coils for continuity.

(6) Refer to the Operator and Organizational Maintenance Manual for wiring harness cleaning, inspection, and repair procedures.

(7) If the wiring harnesses have sustained damage and require repair or rebuild, refer to figures 8-15, 8-16 or 8-17 as required, for layout, identification of material requirements and Appendix A reference for detailed soldering and replacement procedures.

(8) Inspect back plate and chassis for cracks, corrosion, warping and other damage.

(9) Check all hardware for crossed, stripped, and otherwise damaged threads.

(10) Replace all defective parts and parts damaged beyond repair.

d. Assembly. Assemble load bank control box assembly in reverse order of disassembly procedures.

e. Installation. Refer to the Operator and Organizational Maintenance Manual for load bank control box assembly installation procedures.

### 8-22. LOAD BANK HOUSING.

a. Removal. Refer to the Operator and Organizational Maintenance Manual for load bank housing removal instructions.

b. Disassembly.

(1) Remove control box assembly (paragraph 8-21).

(2) Remove heater strips, thermostat and terminal board as outlined in the Operator and Organizational Maintenance Manual.

(3) Complete disassembly of load bank housing by following the sequence of index numbers (1 through 10) assigned to figure 8-17.

c. Cleaning, Inspection, and Repair.

(1) Clean housing in dry cleaning solvent (Federal Specification P-D-680) and dry with compressed air.

(2) Refer to the Operator and Organizational Maintenance Manual for wiring harness cleaning, inspection, and repair procedures.

(3) If the wiring harnesses have sustained damage and require repair or rebuild, refer to figures 8-18, 8-19, or 8-20 as required for layout, identification of material requirements and Appendix A references for detailed soldering and replacement procedures.

(4) Inspect housing assembly for cracks, breaks, warping and other damage. Replace housing assembly if damaged beyond repair.

d. Assembly. Assemble load bank housing in reverse order of removal procedures.

e. Installation. Refer to the Operator and Organizational Maintenance Manual for load bank housing installation instructions.

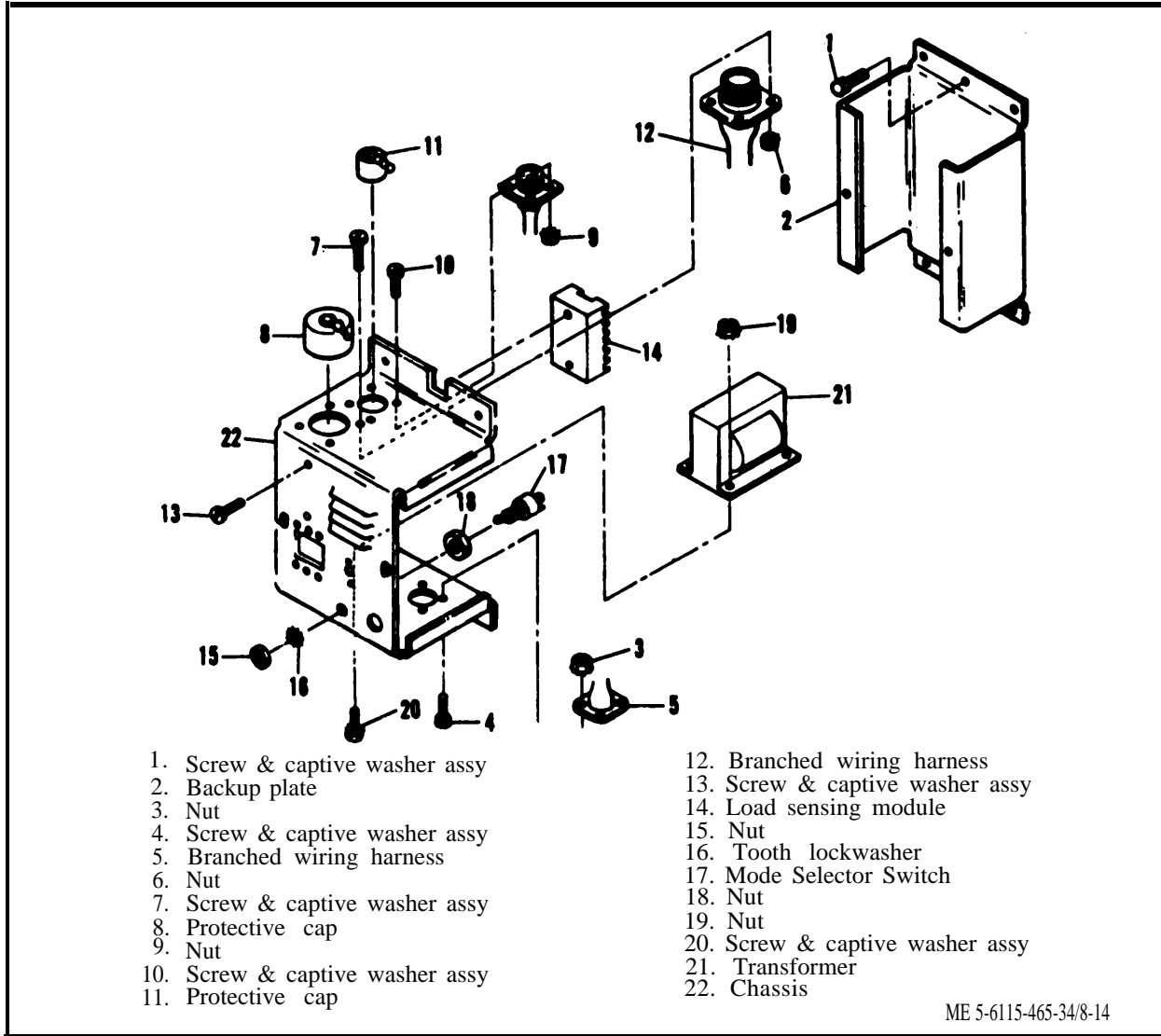

Figure 8-14. Load Bank Control Box Assembly, Exploded View

8-23. WIRING HARNESES.

a. Refer to the Operator and Organizational Maintenance Manual for wiring harness removal, cleaning, inspection, and repair procedure.

b. If the wiring harness has sustained damage and requires repair or rebuild, refer to figures 8-21 or 8-22 for layout, identification, and material requirements and Appendix A for detailed soldering and replacement procedures.

c. Refer to the Operator and Organizational Maintenance Manual for wiring harness installation instructions.

WIRE ROUTING LIST							
WIRE MARKING	TERMINATION			WIRE FIND NO REF	WIRE FIND NO REF	WIRE LENGTH REF	MARKING COLOR
	FROM	FIND NO REF	TO				
X119E16	J4-B	1	A1-12	2	3	6.00	BLACK
X116E16	J4-B	1	A1-11	2	3	6.00	BLACK
X117E16	J4-C	1	A1-10	2	3	6.00	BLACK
D29H16	J4-D	1	A1-9	2	3	3.75	BLACK

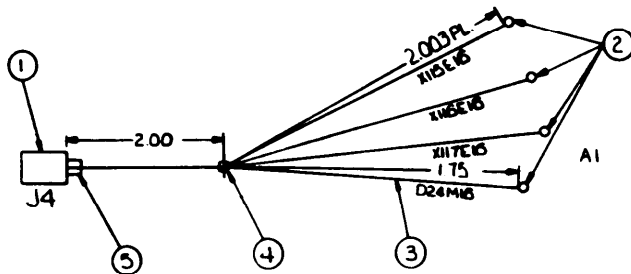

NOTES:

1. INTERPRET DRAWING PER MIL-STD-100.
2. SOLDERING SHALL BE IN ACCORDANCE WITH MIL-STD-454, REQUIREMENT 5.
3. CRIMPED TERMINALS SHALL MEET THE PERFORMANCE REQUIREMENTS OF MIL-T-7920.
4. WIRE MARKING TO BE IN ACCORDANCE WITH MIL-W-5000 EXCEPT THAT LENGTH BETWEEN GROUPS OF NUMBERS SHALL NOT EXCEED 6.00 INCHES.
5. REFERENCE:  
WIRING DIAGRAM: 72-2826  
SCHEMATIC DIAGRAM: 72-2827
6. INSTALL STRAP, FIND NO. 4, AT EACH CABLE BREAKOUT.
7. INSTALL INSULATION SLEEVING .75 LONG FIND NO. 5, OVER EACH CONDUCTOR AT CONNECTOR FIND NO. 1.

5			CLASS 1 .125 ID	AR	INSULATION TUBING FORM II	MIL-T-631		
4			MS3367-5-9	AR	STRAP ADJUSTABLE	MIL-S-23190		
3			MS006-2-16	AR	WIRE ELECTRICAL NO. 16 AWG	MIL-W-5006-2		
2			MS25036-106	4	TERMINAL LUG NO. 6 STUD 16 AWG			
1			MS3102R18-4P	1	CONNECTOR RECEPTACLE	J4		
FIND NO	SYM	CODE IDENT	DWG SIZE	PART OR IDENTIFYING NO	QTY REQD	NOMENCLATURE OR DESCRIPTION	SPECIFICATION	MATERIAL

LIST OF MATERIAL

ME 5-6115-465-34/8-15

TMM 5-6115-465-34  
 TO 35C3-3-446-2  
 NAVFAC P-8-625-34  
 TMM 06658B/06658D-34

Figure 8-15. Control Box Assembly Wiring Harness, Drawing No. 72-2868

WIRE MARKING	TERMINATION				WIRE FIND NO REF	WIRE LENGTH REF	MARKING COLOR
	FROM	FIND NO REF	TO	FIND NO REF			
	X2100	J3-A	1	CR1-A			
X2200	J3-B	1	CR1-B	5	7	7.00	BLACK
X2300	J3-C	1	CR1-C	5	7	7.75	BLACK
X13400	J3-D	1	J5-K	2	7	10.00	BLACK
X51C16	J5-A	2	S1-35	4	6	3.50	BLACK
X50C16	J5-B	2	S1-34	4	6	11.50	BLACK
X49C16	J5-C	2	S1-33	4	6	10.50	BLACK
X48C16	J5-D	2	S1-32	4	6	9.25	BLACK
X47C16	J5-E	2	S1-29	4	6	7.50	BLACK
X46C16	J5-F	2	S1-28	4	6	12.25	BLACK
X45C16	J5-G	2	S1-23	4	6	10.25	BLACK
X44C16	J5-H	2	S1-22	4	6	9.75	BLACK
X43C16	J5-I	2	S1-19	4	6	8.00	BLACK
X42C16	J5-J	2	S1-18	4	6	11.50	BLACK
X41C16	J5-K	2	S1-13	4	6	10.25	BLACK
X40C16	J5-L	2	S1-12	4	6	9.00	BLACK
X40C16	J5-O	2	S1-1	3	6	4.00	BLACK
X40C16	J5-S	2	S3-6	3	6	5.50	BLACK
X130016	J5-U	2	T1-2		6	4.25	BLACK
X130016	J5-V	2	S1	3	6	4.50	BLACK
X20016	J5-P	2	CR1-C2	10	6	11.75	BLACK
X11C16	J5-T	2	S3-4	3	6	4.75	BLACK
X12000	CR1-A1	5	S1-11	5	7	7.75	BLACK
X12100	CR1-B1	5	S1-21	5	7	7.75	BLACK
X12200	CR1-C1	5	S1-31	5	7	7.75	BLACK
D20016	S2	3	A1-8	3	6	12.00	BLACK
P33016	S2	3	A1-6	3	6	12.00	BLACK
X40016	S3-5	3	T1-1		6	7.00	BLACK
P30016	CR1-B1	3	A1-3	3	6	10.00	BLACK
P20016	S3-3	3	A1-1	3	6	9.50	BLACK
P30016	S3-1	3	A1-9	3	6	11.75	BLACK
X120016	T1-3		A1-4	3	6	11.25	BLACK
X120016	T1-4		A1-5	3	6	11.25	BLACK
P32016	S3-2	3	A1-3	3	6	11.75	BLACK
P31016	CR1-X2	3	A1-2	3	6	9.00	BLACK

NOTES:

1. INTERPRET DRAWING PER MIL-STD-100.
2. SOLDERING SHALL BE IN ACCORDANCE WITH MIL-STD-454, REQUIREMENT 5.
3. CRIMPED TERMINALS SHALL MEET THE PERFORMANCE REQUIREMENTS OF MIL-T-7928.
4. STRIP WIRES X130016, X123016, X124016 AND X69016, 1/4 INCH AND SOLDER PER NOTE 2.
5. WIRE MARKING TO BE IN ACCORDANCE WITH MIL-W-5088 EXCEPT THAT LENGTH BETWEEN GROUPS OF NUMBERS SHALL NOT EXCEED 6.00 INCHES.
6. REFERENCE:  
 WIRING DIAGRAM: 72-2826  
 SCHEMATIC DIAGRAM: 72-2827
7. INSTALL STRAPS, FIND NUMBERS 9 AND 10, AT 3.0 INCH INTERVALS AND AT EACH CABLE BREAK-OUT.
8. THE WIRE END OF CONNECTOR JS SHALL BE SEALED ALONG THE HARNESS WITH FIND NUMBER 11 FOR NOT LESS THAN 1" FROM THE CONNECTOR SHOULDER.
9. INSTALL INSULATION FIND NUMBER 9 OVER EACH CONDUCTOR AT CONNECTOR. FIND NUMBER 1.

FIND NO	SYM	CODE	QTY REQD	ENG IDENT	SIZE	PART OR IDENTIFYING NO	QTY REQD	NOMENCLATURE OR DESCRIPTION	CONNECTION	SPECIFICATION	MATERIAL
12	C			R		CLASS 1, 2, 0 10	2"	INSULATION TUBING		MIL-I-22053	
11	C			R		72-2806		SEALING COMPOUND, SILICON RUBBER			
10						MS25036-100	1	TERMINAL LUG, NO. 10 STUD, NO. 16 AWG			
9						CLASS 1, 5 10		INSULATION TUBING		MIL-I-22053	
8						MS3367-5-9		STRAP, ADJUSTABLE		MIL-S-23190	
7						MS006/2-8-9		WIRE, ELECTRICAL, NO. 8 AWG		MIL-W-5086/2	
6						MS006-2-16-9		WIRE, ELECTRICAL, NO. 16 AWG		MIL-W-5086/2	
5						MS25036-115	9	TERMINAL LUG, NO. 10 STUD, NO. 8 AWG			
4						MS25036-153	12	TERMINAL LUG, NO. 8 STUD, NO. 16 AWG			
3						MS25036-106	21	TERMINAL LUG, NO. 6 STUD, NO. 16 AWG			
2						MS3102032-6P	1	CONNECTOR RECEPTACLE	J5		
1						MS3102032-17P	1	CONNECTOR RECEPTACLE	J3		

LIST OF MATERIAL

Figure 8-16. Control Box Assembly Branched Wiring Harness (Sheet 1 of 2), Drawing No. 72-2828



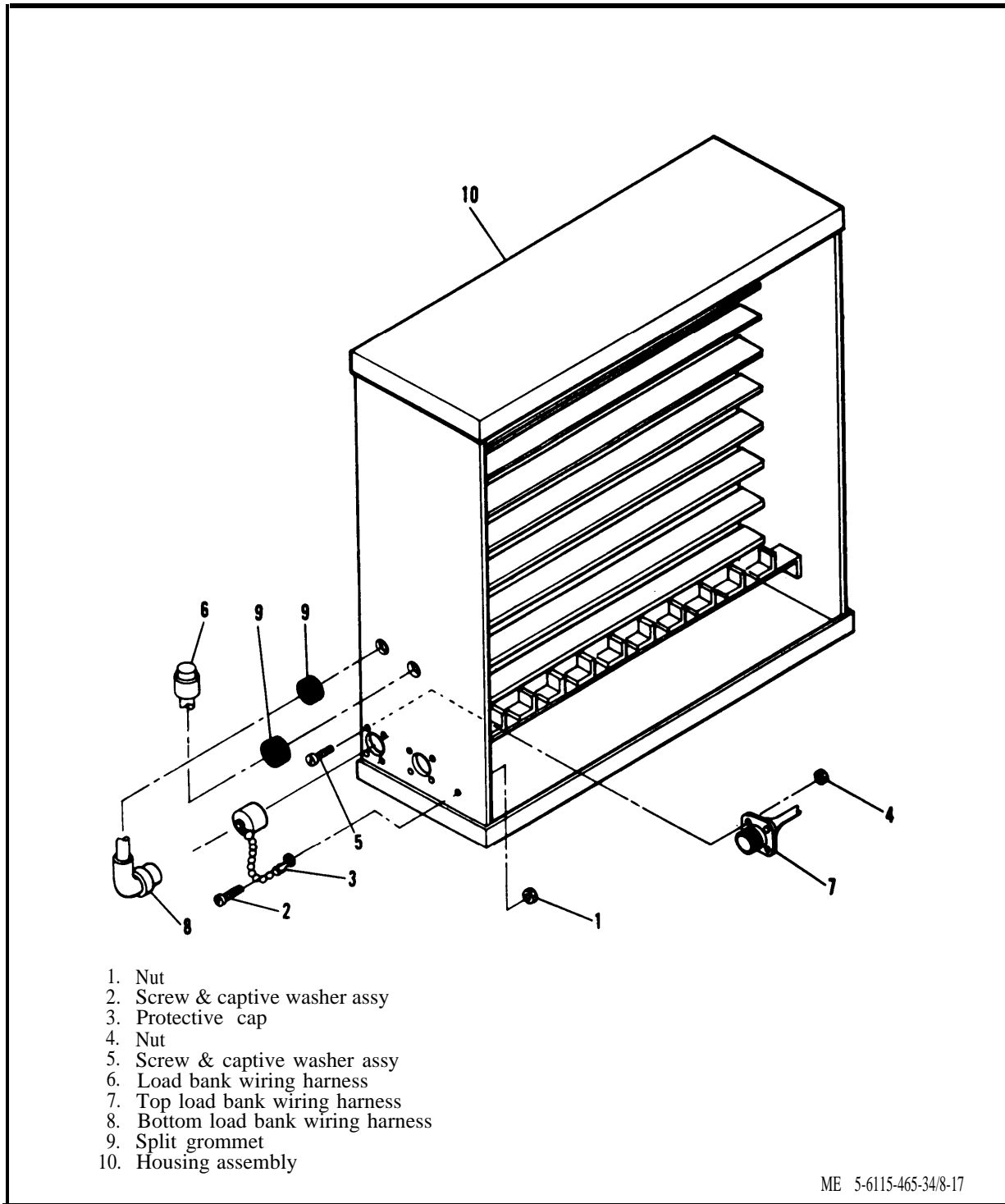

Figure 8-17. Load Bank Housing, Exploded View



WIRE RUNNING LIST							
WIRE MARKING	TERMINATION FROM		TERMINATION TO		WIRE FIND NO.	WIRE LENGTH (REF.)	MARKING COLOR
	FIND NO. (REF.)	FIND NO. (REF.)	FIND NO. (REF.)	FIND NO. (REF.)			
X51816	P2-A	1	R24-2	4	6	52.75	BLACK
X50816	P2-B	1	R22-2	4	6	51.00	BLACK
X49816	P2-C	1	R20-2	4	6	49.25	BLACK
X48816	P2-D	1	R18-2	4	6	47.50	BLACK
X47816	P2-E	1	R16-2	4	6	45.75	BLACK
X46816	P2-F	1	R14-2	4	6	44.00	BLACK
X45816	P2-G	1	R12-2	4	6	42.25	BLACK
X44816	P2-H	1	R10-2	4	6	40.50	BLACK
X43816	P2-I	1	R8-2	4	6	38.75	BLACK
X42816	P2-J	1	R6-2	4	6	37.00	BLACK
X41816	P2-K	1	R4-2	4	6	35.25	BLACK
X40816	P2-L	1	R2-2	4	6	33.50	BLACK
X60816	P2-D	1	R9-1	4	6	29.00	BLACK
X13016	P2-U	1	BUSS	4	6	32.00	BLACK
X13E16	P2-V	1	BUSS	4	6	32.00	BLACK
X68816	P2-S	1	R17-1	4	6	36.00	BLACK
X13C6	P2-X	1	BUSS	3	5	30.75	BLACK
X23C16	P2-P	1	P1-d	-	6	31.00	BLACK
X11816	P2-T	1	P1-b	-	6	31.00	BLACK

NOTES: (CONTINUED)

8. FOR FULL SIZE HARNESS BOARD LAYOUT SEE DRAWING 72-2823.
9. MARK WITH "36024-72-2826" IN ACCORDANCE WITH MIL-STD-130.

NOTES:

1. INTERPRET DRAWING PER MIL-STD-100.
2. ALL SOLDERED CONNECTIONS SHALL BE IN ACCORDANCE WITH MIL-STD-454, REQUIREMENT 5 USING SOLDER FIND NO. 8.
3. INSTALL STRAPS, FIND NO. 7, AT APPROXIMATELY 2.5 INTERVALS AND AT EACH CABLE BREAK-OUT.
4. WIRE MARKING TO BE IN ACCORDANCE WITH MIL-W-5088 EXCEPT THAT LENGTH BETWEEN GROUPS OF NUMBERS SHALL NOT EXCEED 6 INCHES.
5. CRIMPED TERMINALS SHALL MEET THE PERFORMANCE REQUIREMENTS OF MIL-T-7928.
6. STRIP .25 EACH WIRE WITHOUT TERMINATION AND TIN IN ACCORDANCE WITH MIL-STD-454 REQUIREMENT 5.
7. REFERENCES:
  - a) FOR WIRING DIAGRAM SEE DRAWING 72-2826.
  - b) FOR SCHEMATIC DIAGRAM SEE DRAWING 72-2827.

FIND NO.	SYM.	CODE	QTY	DESCRIPTION	SPECIFICATION	MATERIAL
8		MS25251-8	3	PLUG END SEAL		
7		MS3367-5-9	AR	STRAP TIEDOWN ADJUSTABLE SELF-CLINCHING PLASTIC TYPE I CLASS 1		
6		MS17412-16	AR	WIRE ELECT. FLUOROCARBON INSUL. ABRASION RES. EXTRUDED TFE. MIL. CTD. COP. NO. 16 AWG		
5		MS17412-6	AR	WIRE ELECT. FLUOROCARBON INSUL. ABRASION RES. EXTRUDED TFE. MIL. CTD. COP. NO. 6 AWG		
4		MS20659-104	16	TERM. LUG CRP. STYLE COP. RING TONGUE BELL MOUTHED TYPE I. CLASS 1, NO. 10 STUD. NO. 16 AWG WIRE		
3		MS20659-130	1	TERMINAL LUG CRIMP STYLE COP. RING TONGUE BELL MOUTHED TYPE I, CLASS 1, NO. 10 STUD. NO. 6 AWG WIRE		
2		CLASS 1, 1.00 ID	AR	INSUL. SLVG. ELECT. HEAT SHRINKABLE FLEX. POLYOLEFIN. CROSSLINKED	MIL-I-23053/3	
1		MS3106F32-65	1	CONNECTOR, PLUG, ELECT. STRAIGHT		

ME 5-6115-465-34/8-18 (1)

Figure 8-18. Load Bank Wiring Harness (Sheet 1 of 2), Drawing No. 72-2823

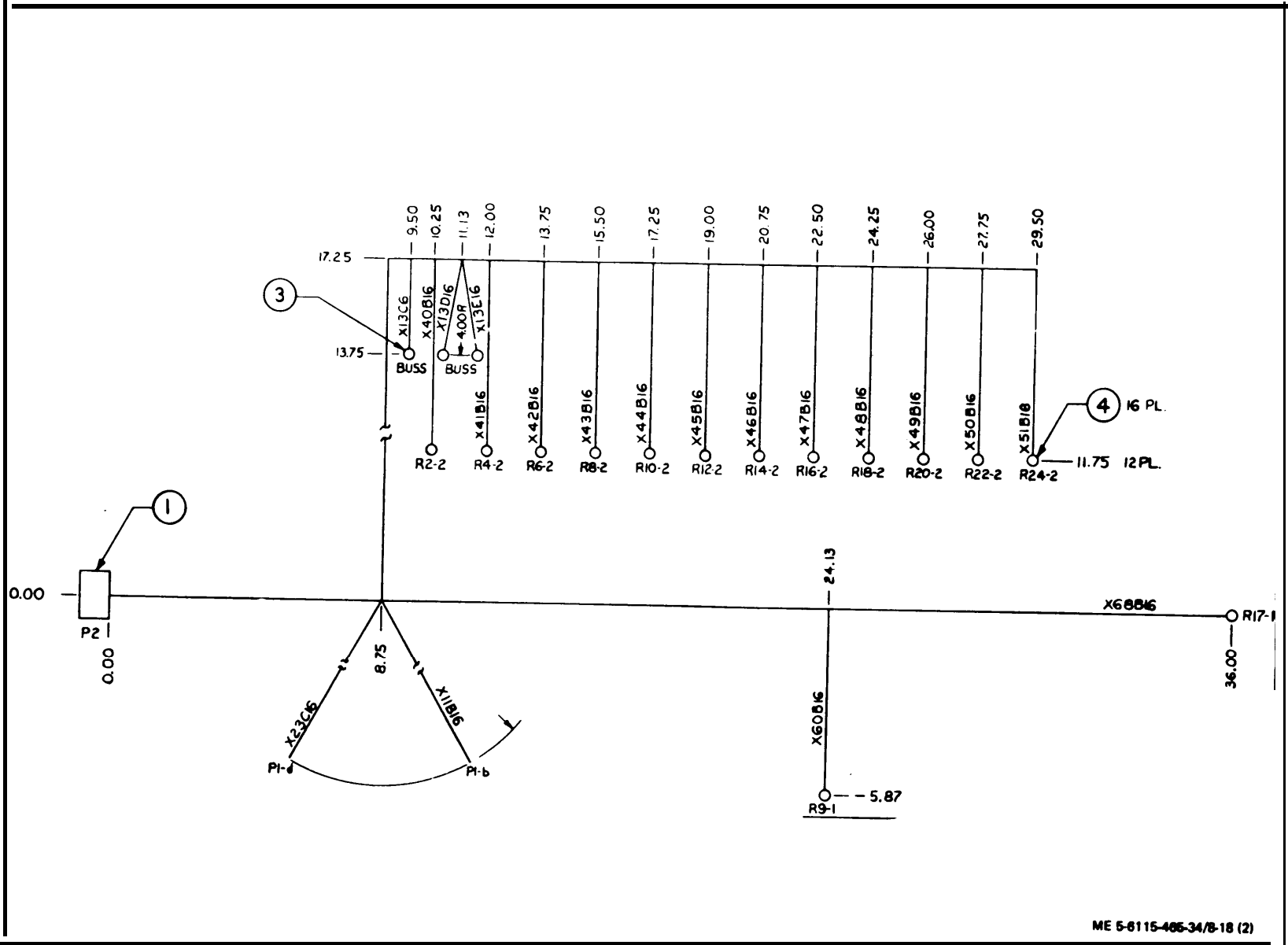
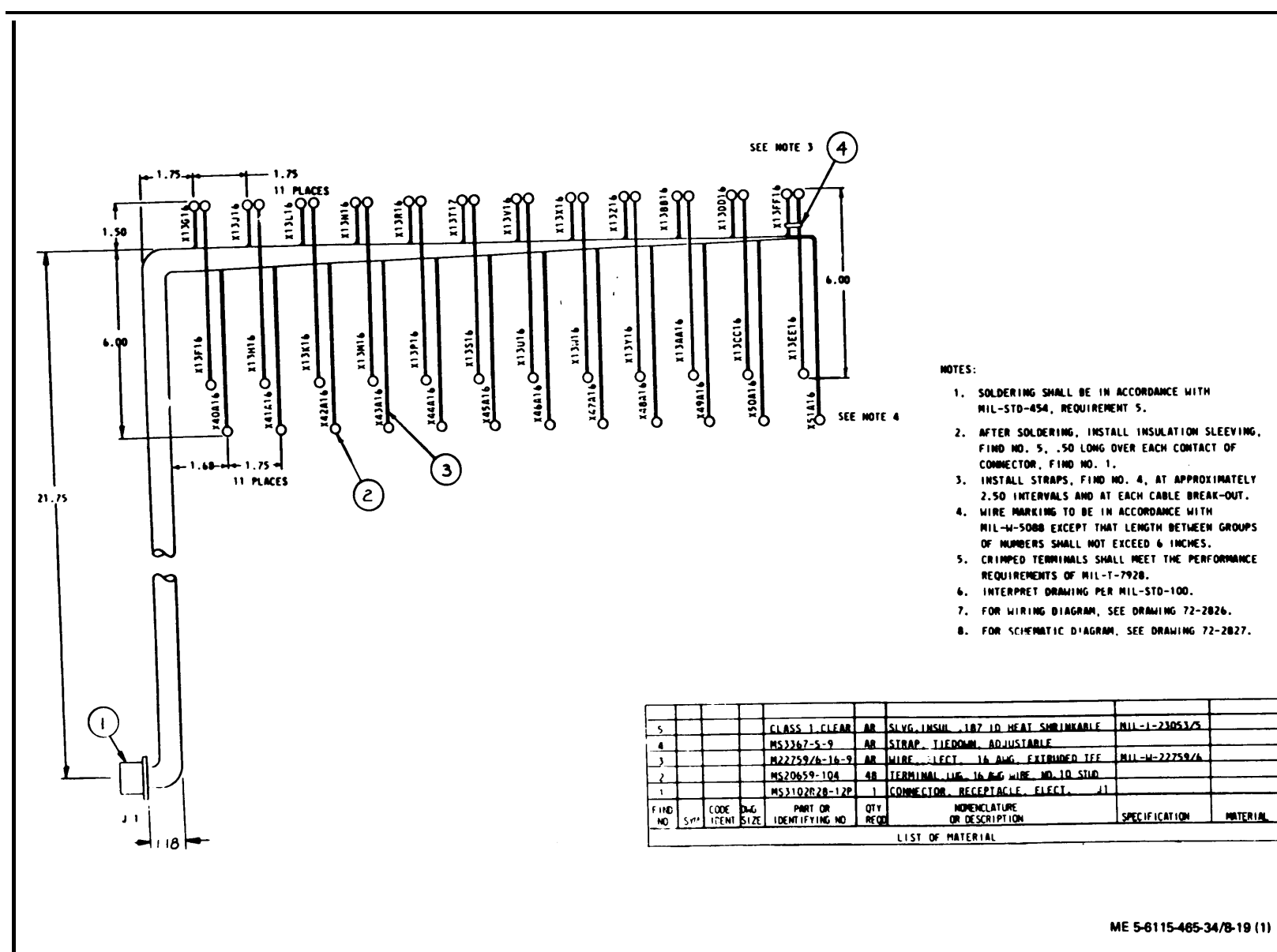

Figure 8-18. Load Bank Wiring Harness (Sheet 2 of 2), Drawing No. 72-2823



NOTES:

1. SOLDERING SHALL BE IN ACCORDANCE WITH MIL-STD-454, REQUIREMENT 5.
2. AFTER SOLDERING, INSTALL INSULATION SLEEVING, FIND NO. 5, .50 LONG OVER EACH CONTACT OF CONNECTOR, FIND NO. 1.
3. INSTALL STRAPS, FIND NO. 4, AT APPROXIMATELY 2.50 INTERVALS AND AT EACH CABLE BREAK-OUT.
4. WIRE MARKING TO BE IN ACCORDANCE WITH MIL-W-5080 EXCEPT THAT LENGTH BETWEEN GROUPS OF NUMBERS SHALL NOT EXCEED 6 INCHES.
5. CRIMPED TERMINALS SHALL MEET THE PERFORMANCE REQUIREMENTS OF MIL-T-7928.
6. INTERPRET DRAWING PER MIL-STD-100.
7. FOR WIRING DIAGRAM, SEE DRAWING 72-2826.
8. FOR SCHEMATIC DIAGRAM, SEE DRAWING 72-2827.

SEE NOTE 3 (4)

SEE NOTE 4

11 PLACES

11 PLACES

1.50

1.75

1.75

6.00

21.75

1.60

1.75

1.18

J 1

1

2

3

4

5

ME 5-6115-485-34/8-19 (1)

Figure 8-19. Top Load Bank Wiring Harness (Sheet 1 of 2), Drawing No. 72-2822

X132A16	J1-b	1	J1-d	1	3	4.00	BLACK
X40A16	J1-A	1	R2-2	2	3	30.00	BLACK
X13G16	J1-B	1	BUSS	2	3	25.50	BLACK
X41A16	J1-C	1	R4-2	2	3	31.75	BLACK
X13J16	J1-D	1	BUSS	2	3	27.25	BLACK
X42A16	J1-E	1	R6-2	2	3	33.50	BLACK
X13L16	J1-F	1	BUSS	2	3	29.00	BLACK
X43A16	J1-G	1	R8-2	2	3	35.25	BLACK
X13M16	J1-H	1	BUSS	2	3	30.75	BLACK
X44A16	J1-J	1	R10-2	2	3	37.00	BLACK
X13N16	J1-K	1	BUSS	2	3	32.50	BLACK
X45A16	J1-L	1	R12-2	2	3	38.75	BLACK
X13P16	J1-M	1	BUSS	2	3	34.25	BLACK
X46A16	J1-N	1	R14-2	2	3	40.50	BLACK
X13V16	J1-P	1	BUSS	2	3	36.00	BLACK
X47A16	J1-Q	1	R16-2	2	3	42.25	BLACK
X13X16	J1-R	1	BUSS	2	3	37.75	BLACK
X48A16	J1-T	1	R18-2	2	3	44.00	BLACK
X13Z16	J1-U	1	BUSS	2	3	39.50	BLACK
X49A16	J1-V	1	R20-2	2	3	45.75	BLACK
X135B16	J1-W	1	BUSS	2	3	41.25	BLACK
X50A16	J1-X	1	R22-2	2	3	47.50	BLACK
X130D16	J1-Y	1	BUSS	2	3	43.00	BLACK
X51A16	J1-Z	1	R24-2	2	3	49.25	BLACK
X13F16	J1-a	1	BUSS	2	3	44.75	BLACK
X13F16	BUSS	2	R1-2	2	3	6.00	BLACK
X13H16	BUSS	2	R3-2	2	3	6.00	BLACK
X13K16	BUSS	2	R5-2	2	3	6.00	BLACK
X13L16	BUSS	2	R7-2	2	3	6.00	BLACK
X13P16	BUSS	2	R9-2	2	3	6.00	BLACK
X13S16	BUSS	2	R11-2	2	3	6.00	BLACK
X13U16	BUSS	2	R13-2	2	3	6.00	BLACK
X13V16	BUSS	2	R15-2	2	3	6.00	BLACK
X13Y16	BUSS	2	R17-2	2	3	6.00	BLACK
X13Z16	BUSS	2	R19-2	2	3	6.00	BLACK
X130E16	BUSS	2	R21-2	2	3	6.00	BLACK
X131E16	BUSS	2	R23-2	2	3	6.00	BLACK
WIRE NO.	FROM	FIND	TO	FIND	WIRE	WIRE LENGTH	MARKING COLOR
TERMINATION		TERMINATION					
RUNNING WIRE LIST							

ME 5-6115-465-34/8-19 (2)

Figure 8-19. Top Load Bank Wiring Harness (Sheet 2 of 2)  
 Drawing No. 72-2822

WIRE RUNNING LIST						
WIRE MARKING	TERMINATION			WIRE FIND NO. REF.	WIRE LENGTH REF.	
	FROM	FIND NO. REF.	TO			
X52A16	P1-A	1	R1-1	6	5	25.00
X53A16	P1-B	1	R2-1	6	5	25.85
X54A16	P1-C	1	R3-1	6	5	26.75
X55A16	P1-D	1	R4-1	6	5	27.60
X56A16	P1-E	1	R5-1	6	5	28.50
X57A16	P1-F	1	R6-1	6	5	29.35
X58A16	P1-G	1	R7-1	6	5	30.25
X59A16	P1-H	1	R8-1	6	5	31.10
X60A16	P1-J	1	R9-1	6	5	32.00
X61A16	P1-K	1	R10-1	6	5	32.85
X62A16	P1-L	1	R11-1	6	5	33.75
X63A16	P1-M	1	R12-1	6	5	34.60
X64A16	P1-N	1	R13-1	6	5	35.50
X65A16	P1-P	1	R14-1	6	5	36.35
X66A16	P1-R	1	R15-1	6	5	37.25
X67A16	P1-S	1	R16-1	6	5	38.10
X68A16	P1-T	1	R17-1	6	5	39.00
X69A16	P1-U	1	R18-1	6	5	39.85
X70A16	P1-V	1	R19-1	6	5	40.75
X71A16	P1-W	1	R20-1	6	5	41.60
X72A16	P1-X	1	R21-1	6	5	42.50
X73A16	P1-Y	1	R22-1	6	5	43.35
X74A16	P1-Z	1	R23-1	6	5	44.25
X75A16	P1-a	1	R24-1	6	5	45.10
X23C16	P1-d	1	P2-P	-	5	31.00
X11B16	P1-b	1	P2-T	-	5	31.00

NOTES:

1. INTERPRET DRAWING PER MIL-STD-100.
2. SOLDERING SHALL BE IN ACCORDANCE WITH MIL-STD-454, REQUIREMENT 5.
3. INSTALL STRAPS, FIND NO. 7, AT APPROXIMATELY 2.50 INTERVALS AND AT EACH CABLE BREAK-OUT.
4. WIRE MARKING TO BE IN ACCORDANCE WITH MIL-W-5088 EXCEPT THAT LENGTH BETWEEN GROUPS OF NUMBERS SHALL EXCEED 6.00 INCHES.
5. CRIMPED TERMINAL SHALL MEET THE PERFORMANCE REQUIREMENTS OF MIL-T-7928.
6. FOR WIRING DIAGRAM SEE DRAWING 72-2826.
7. FOR SCHEMATIC DIAGRAM SEE DRAWING 72-2827.
8. INSTALL PLUG, FIND NO. 8, IN UNUSED PINS OF CONNECTOR, FIND NO. 1.
9. AFTER SOLDERING, INSTALL INSULATION SLEEVING, FIND NO. 4, .50 LONG OVER EACH CONTACT OF CONNECTOR, FIND NO. 1.

FIG. NO.	SYM.	CODE IDENT.	DWG. SIZE	PART OR IDENTIFYING NO.	QTY. REQD.	NOMENCLATURE OR DESCRIPTION	SPECIFICATION	MATERIAL
8				MS25251-16	2	PLUG, END SEAL		
7				MS3367-5	AR	STRAP, TIEDOWN, ADJUSTABLE		
6				MS2069-10R	24	TERMINAL LUG, NO. 16 AWG WIRE		
5				M227597A-1A-9	AR	WIRE, ELECTRIC, 16 AWG, WHITE		
4				CLASS 1, 1.00 ID	AR	INSUL. SLEEVING, HEAT SHRINKABLE, CLEAR	MIL-I-23053/5	
3				MS3420-16	1	PUSHING, CABLE, ADAPTER		
2				MS3057-16A	1	CLAMP, CABLE		
1				MS3108R28-125	1	CONN. PLUG, ELECT, 90°		

LIST OF MATERIAL

ME 5-6115-465-34/8-20 (1)

Figure 8-20. Bottom Load Bank Wiring Harness (Sheet 1 of 2), Drawing No. 72-2825

TM 5-6115-465-34  
 TO 35C3-S-446-2  
 NAVFAC P-8-625-34  
 TM 06858B/06859D-34

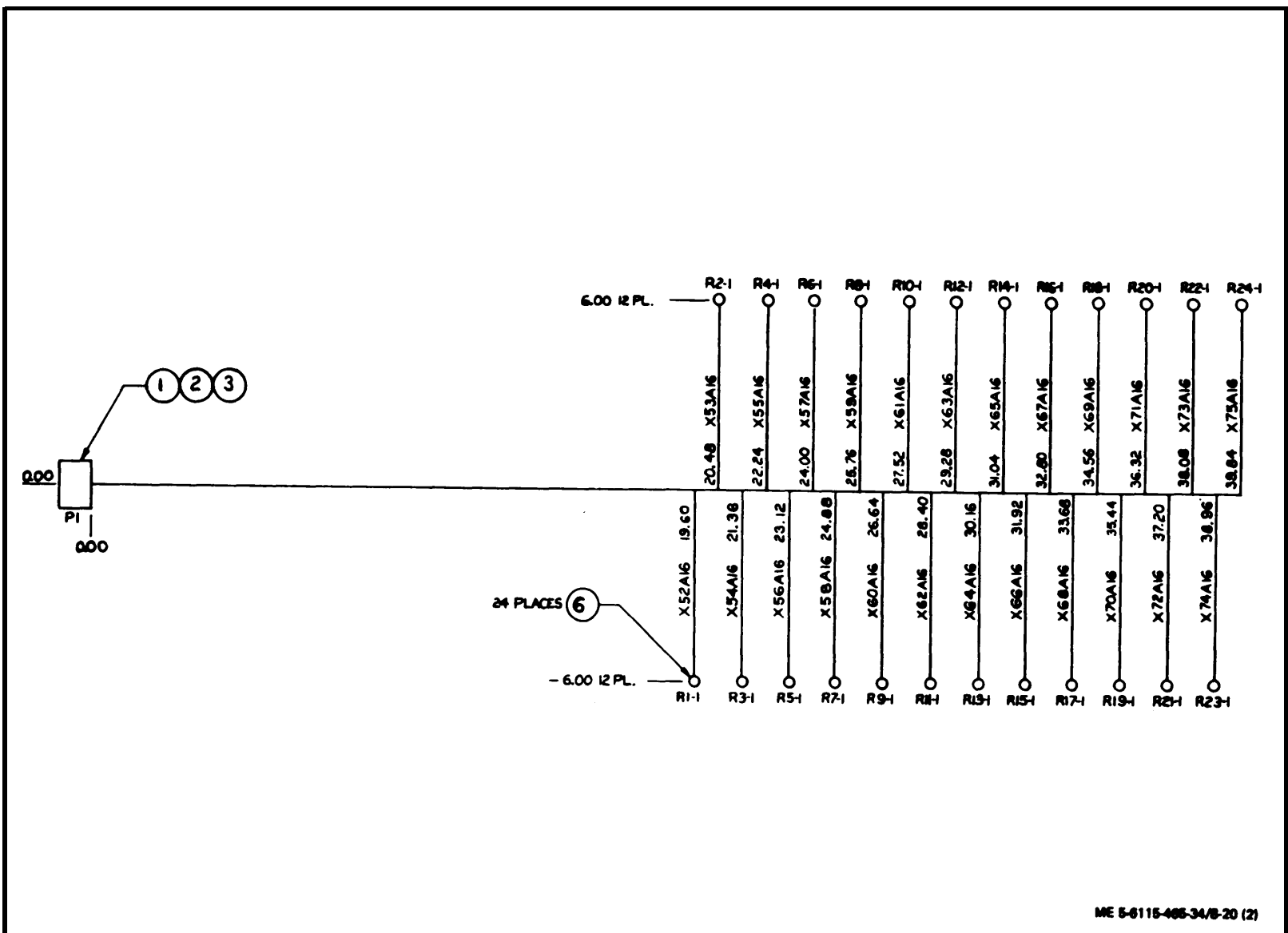

ME 5-6115-465-34/B-20 (2)

Figure 8-20. Bottom Load Bank Wiring Harness (Sheet 2 of 2), Drawing No. 72-2825

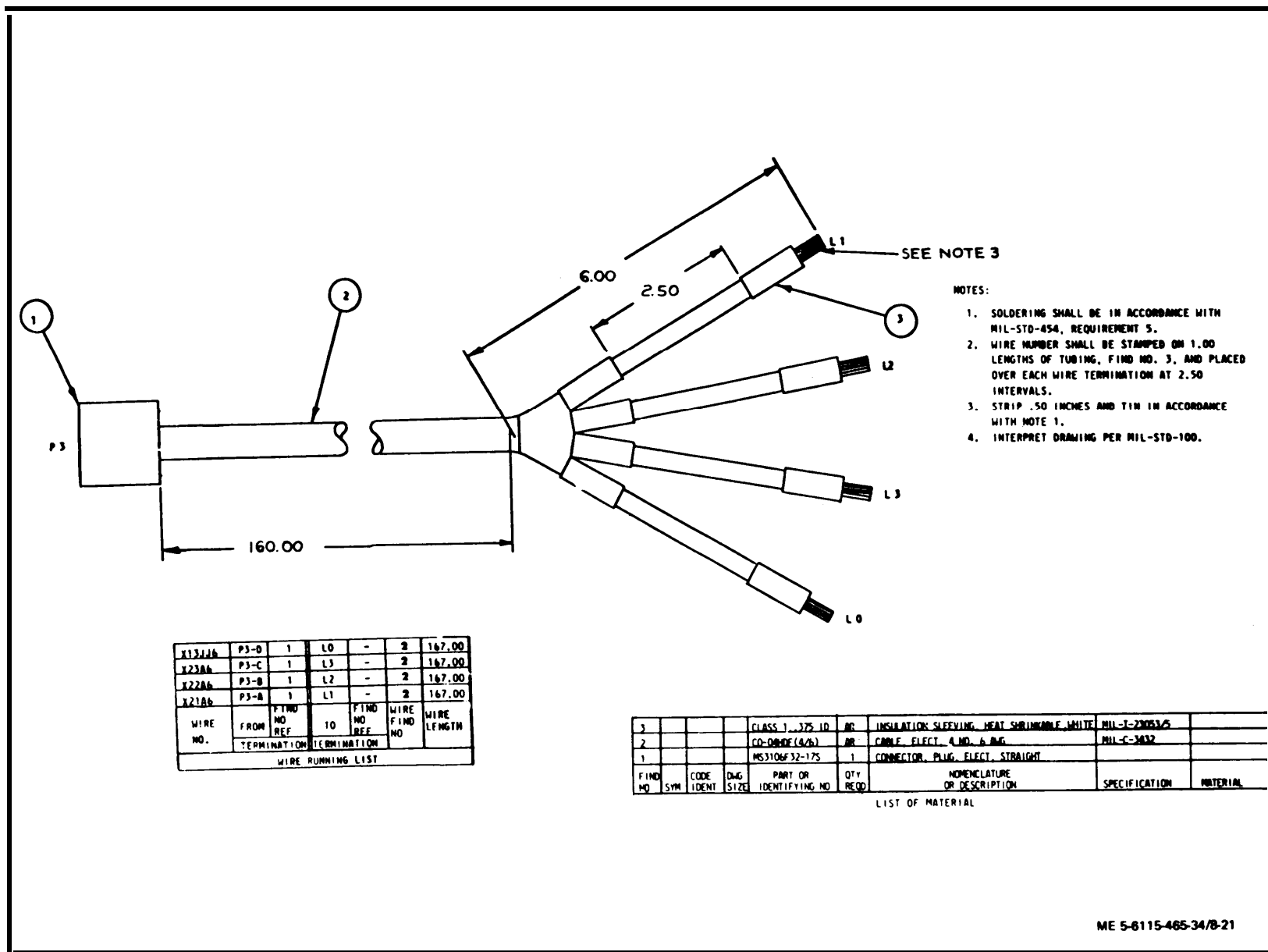

- NOTES:
1. SOLDERING SHALL BE IN ACCORDANCE WITH MIL-STD-454, REQUIREMENT 5.
  2. WIRE NUMBER SHALL BE STAMPED ON 1.00 LENGTHS OF TUBING, FIND NO. 3, AND PLACED OVER EACH WIRE TERMINATION AT 2.50 INTERVALS.
  3. STRIP .50 INCHES AND TIN IN ACCORDANCE WITH NOTE 1.
  4. INTERPRET DRAWING PER MIL-STD-100.

WIRE NO.	FROM TERMINATION	FTNO NO REF	TO TERMINATION	FIND NO REF	WIRE FIND NO	WIRE LFNGTH
X131A6	P3-D	1	L0	-	2	167.00
X23A6	P3-C	1	L3	-	2	167.00
X22A6	P3-B	1	L2	-	2	167.00
X21A6	P3-A	1	L1	-	2	167.00

WIRE RUNNING LIST

FIND NO	SYM	CODE IDENT	DWG SIZE	PART OR IDENTIFYING NO	QTY REQD	NOMENCLATURE OR DESCRIPTION	SPECIFICATION	MATERIAL
3				CLASS 1 .375 ID	NR	INSULATION SLEEVING, HEAT SHRINKABLE, WHITE	MIL-I-22053/2	
2				CO-DMDF (4/2)	NR	CABLE, ELECT, 4 NO. 6 AWG	MIL-C-3432	
1				MS106F32-175	1	CONNECTOR, PLUG, ELECT, STRAIGHT		

LIST OF MATERIAL

TM 5-6115-465-34  
 TO SSC2-3-446-2  
 NAVFAC P-8-625-34  
 TM 06858B/06859D-34

ME 5-6115-465-34/8-21

Figure 8-21. Load Bank Power Wiring Harness, Drawing No. 72-2829

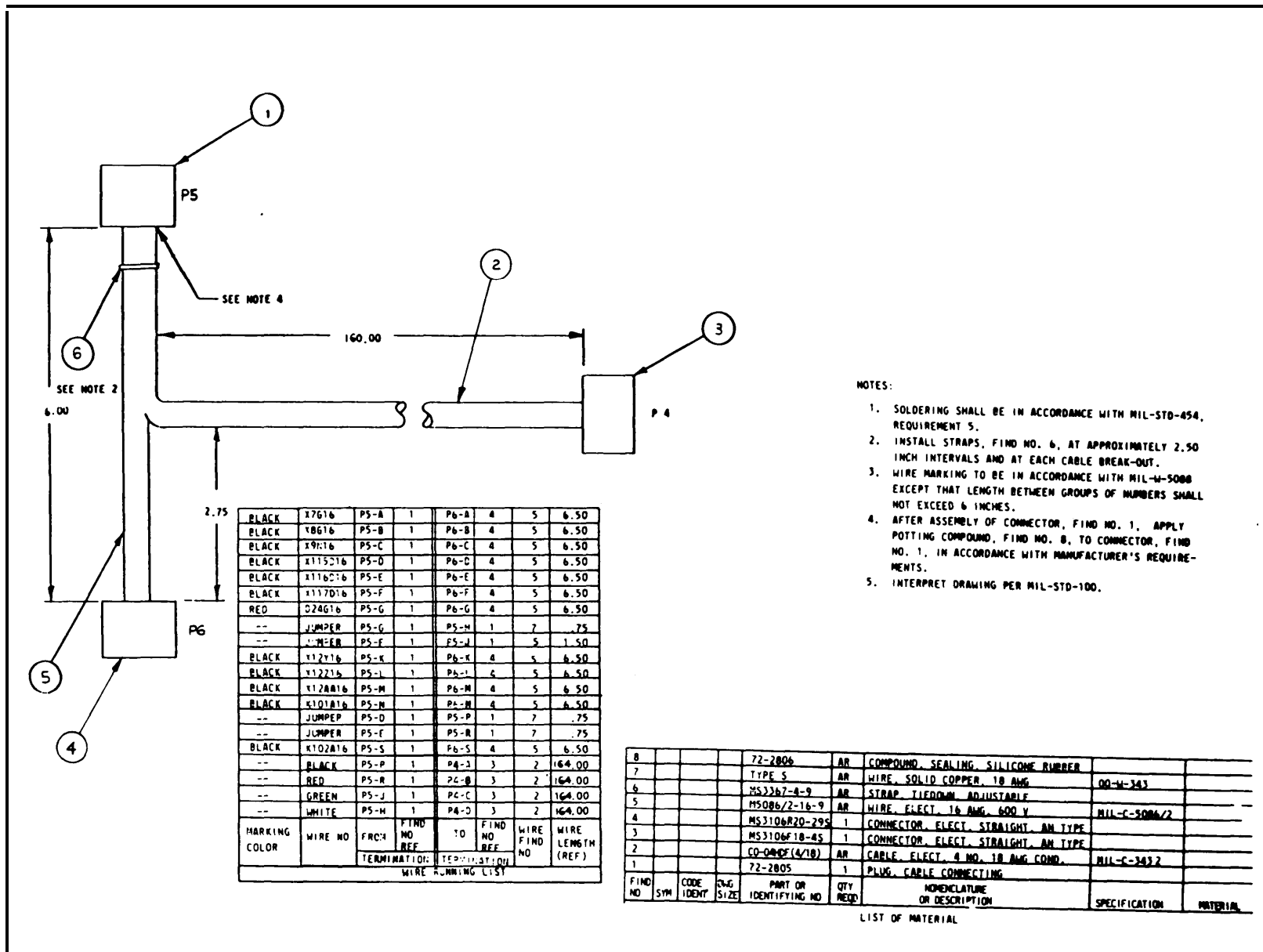

TM 5-6115-465-34  
 TO 35C2-3-446-2  
 NAVFAC P-8-625-34  
 TM 06858B/06859D-34

- NOTES:
1. SOLDERING SHALL BE IN ACCORDANCE WITH MIL-STD-454, REQUIREMENT 5.
  2. INSTALL STRAPS, FIND NO. 6, AT APPROXIMATELY 2.50 INCH INTERVALS AND AT EACH CABLE BREAK-OUT.
  3. WIRE MARKING TO BE IN ACCORDANCE WITH MIL-W-5000 EXCEPT THAT LENGTH BETWEEN GROUPS OF NUMBERS SHALL NOT EXCEED 6 INCHES.
  4. AFTER ASSEMBLY OF CONNECTOR, FIND NO. 1, APPLY POTTING COMPOUND, FIND NO. 8, TO CONNECTOR, FIND NO. 1, IN ACCORDANCE WITH MANUFACTURER'S REQUIREMENTS.
  5. INTERPRET DRAWING PER MIL-STD-100.

MARKING COLOR	WIRE NO	FRC#	FIND NO REF	TO FIND NO REF	WIRE FIND NO	WIRE LENGTH (REF)
BLACK	X7616	PS-A	1	P6-A	4	5 6.50
BLACK	X8616	PS-B	1	P6-B	4	5 6.50
BLACK	X9716	PS-C	1	P6-C	4	5 6.50
BLACK	X115216	PS-D	1	P6-C	4	5 6.50
BLACK	X116216	PS-E	1	P6-E	4	5 6.50
BLACK	X117016	PS-F	1	P6-F	4	5 6.50
RED	O24616	PS-G	1	P6-G	4	5 6.50
--	JUMPER	PS-G	1	PS-H	1	7 .75
--	JUMPER	PS-F	1	PS-J	1	5 1.50
BLACK	X12716	PS-K	1	P6-K	4	5 6.50
BLACK	X12216	PS-L	1	P6-L	6	5 6.50
BLACK	X12A16	PS-M	1	P6-M	4	5 6.50
BLACK	X101A16	PS-N	1	P6-N	4	5 6.50
--	JUMPER	PS-D	1	PS-P	1	7 .75
--	JUMPER	PS-E	1	PS-R	1	7 .75
BLACK	X102A16	PS-S	1	P6-S	4	5 6.50
--	BLACK	PS-P	1	P4-3	3	2 164.00
--	RED	PS-R	1	P4-B	3	2 164.00
--	GREEN	PS-J	1	P4-C	3	2 164.00
--	WHITE	PS-H	1	P4-D	3	2 164.00

TERMINATION: TERMINATION  
 WIRE RUNNING LIST

FIND NO	SYM	CODE IDENT	QTY REQ	PART OR IDENTIFYING NO	QTY REQ	NOMENCLATURE OR DESCRIPTION	SPECIFICATION	MATERIAL
8				72-2806	AR	COMPOUND SEALING SILICONE RUBBER		
7				TYPE 5	AR	WIRE SOLID COPPER 18 AWG		
6				MS3367-4-9	AR	STRAP TIEDOWN ADJUSTABLE	DD-W-343	
5				MS086/2-16-9	AR	WIRE ELECT. 16 AWG 600 V	MIL-C-5006/2	
4				MS3106R20-295	1	CONNECTOR ELECT STRAIGHT AN TYPE		
3				MS3106F18-45	1	CONNECTOR ELECT STRAIGHT AN TYPE		
2				CO-04MP(4/18)	AR	CABLE ELECT. 4 NO. 18 AWG COND.	MIL-C-3432	
1				72-2805	1	PLUG CABLE CONNECTING		

LIST OF MATERIAL

Figure 8-22. Load Bank Signal Wiring Harness, Drawing No. 72-2830



Section V. ACOUSTIC SUPPRESSION KIT

8-24. GENERAL

The acoustic suppression kit provides the ability to lower the noise level of the generator set to 70 dB(A) at 7 meters. It consists of panels, doors, and components that cover or replace original components of the generator set. The generator set is operated and maintained in the same manner; however, access to components and operation will change slightly due to configuration changes.

Remember that the overall weight and cube of the generator set will increase with the acoustic suppression kit installed. (Refer to TM 5-6115-465-12, para 1-6.)

Inspect the components of the acoustic suppression kit upon delivery for bends, cracks, dents, missing components, or other damage.

8-25. ACOUSTIC SUPPRESSION KIT INSTALLATION AND REMOVAL.

**NOTE**

Do not allow components with rubber seals to slide on surfaces. Damage to rubber seals will result.

- a. Prepare generator set for installation of acoustic suppression kit.

**WARNING**

Do not use hoisting equipment with maximum capacity less than 5,000 pounds. Do not allow generator set to swing while suspended. Do not allow personnel under generator set or components of acoustic suppression kit when hoisted or lifted. Death or severe injury may result.

**CAUTION**

Use a minimum bridle of 5 feet on the hoisting sling to avoid undue side pressure on the lifting frame.

**NOTE**

If generator set is trailer-mounted, generator set must be removed from trailer and rubber isolators supplied with kit placed between the generator set and trailer mounting surface. When installing the generator set, attach anti-rotation clips, and attach the mounting bolts. Bolts should be torqued to 5 ft-lb (6.80 N.m), jam nuts installed. (Jam nuts are common hardware items.) Once the acoustic suppression kit is installed, gen set will require 1 inch ground clearance. Do not skid gen set with acoustic suppression kit installed. Do not fork lift unless both side panel skirts are in the raised position. If generator set is trailer mounted, the trailer brackets supplied with kit must be installed. The brackets allow for the extended length when the acoustic suppression kit is installed.

(1) Refer to operator and organizational maintenance manual, para 3-134, and remove the following component from the generator set: battery box doors, radiator grille, side doors, louver doors under control panel, control panel doors, and both front and rear top covers.

**NOTE**

Remove all data plates and schematics from generator panels. Mount generator set data plate on lower right side of control panel using data plate as a pattern for the rivet holes. Mount schematics and data plates on rings supplied with acoustic suppression kit, and place behind document box mounted on rear panel. Data plates and schematics should be on separate rings. Reinstall radiator mounting bolts after removing radiator grille. One capscrew in top left rear door hinge cannot be removed. Install hex nut on this capscrew to prevent rattles.

**NOTE**

Some original hardware will be used to mount the acoustic suppression kit. Store all components removed and not used from the generator set and acoustic suppression kit installation components in accordance with local SOP. If acoustic suppression kit is to be removed, original generator components must be reinstalled.

(2) Refer to operator and organizational maintenance manual, para 3-102, and remove the rain cap from the exhaust flange.

**WARNING**

Disconnect batteries prior to removing the ground stud. Death or serious injury could result.

**WARNING**

Fuel tank is behind skid. Do not allow drill bit to enter fuel tank. Death, fire, or serious injury could result.

(3) Locate left rear tiedown on skid base. Remove the ground stud. Measure down 5-1/8 inches from lip of skid base, and 3-5/8 inches from vertical lip of skid base, Center punch where two lines meet. Refer to figure 8-24. Using ground stud as a guide, drill two holes in skid base. (Refer to figure 8-23.) Install ground stud in holes. Install ground plate under ground stud. It may be necessary to remove wire ties from the ground wire to the ground stud.

**NOTE**

To remove the acoustic suppression kit from shipping container, refer to steps (25) through (14) and Step (8) of para b(1) in reverse order. Ensure all component are removed from shipping container.

b. Install acoustic suppression kit on generator act.

**CAUTION**

Location of first hole is critical. Read steps (1) thru (4) and study figure 8-24 carefully before marking and drilling first hole.

(1) Using template supplied with acoustic suppression kit in vertical position, mark rear of skid base in two positions. (Refer to figure 8-24.)

(2) Using template in horizontal position, mark rear of skid base in two positions. (Refer to figure 8-24.)

(3) After making four marks, draw a vertical and horizontal line through the marks. (Refer to figure 8-24.)

(4) Where lines cross, drill a 1/2-inch hole. (Refer to figure 8-24.)

**NOTE**

Do not tighten capscrews in step 5.

(5) Position mounting member on skid base, and install the capscrew, flatwashers, lock-washer; and nut.

(6) Position the mounting member until it is parallel to the top of the skid base. Mounting member's top surface should be 7/8 inch lower than top of skid base. (Refer to figure 8-25.) Use a C-clamp to hold the mounting member in position.

(7) Measure mounting member along skid, and using mounting member as a template, drill end hole, and install capscrew, flatwashers, lockwasher, and nut. Measurement from top of member to top of skid base must be 7/8 inch before holes are drilled. (Refer to figure 8-25.)

(8) Drill holes and install remaining capscrews, flatwashers, lockwashers, and nuts on mounting member. Heads of capscrews must be outside of skid. Due to location of tool box, one head of capscrews must be positioned in tool box. This capscrew is longer than other capscrews. (Refer to figure 8-25.) Do not tighten capscrews.

(9) Repeat steps (1) thru (5) for mounting member on other skid.

(10) Remove oil drain plug. Install fitting, hose, and clamp supplied with acoustic suppression kit.

(11) Position roof stiffeners and sealing angle on generator set. Install hexhead capscrews and lockwashers to secure roof stiffeners. Do not tighten capscrews on sealing angle. (Refer to figure 8-23.)

#### NOTE

Lifting clevises must be in raised position prior to installing side panels. Ensure rubber mounting pads remain in position on side panel studs when installing on mounting member.

#### NOTE

Bottom tray assembly will only go onto unit one way. Long end of tray should go towards exhaust end of generator set. Note location of weld nuts in relation to fork lift tunnels. Bottom tray assembly must be cleaned and rubber seal greased with GAA prior to installing.

(12) Using a suitable lifting device, raise generator set and place 6"x6" blocks under skids. Lower generator set onto blocks,

(13) Grease inside of generator set skids with grease (GAA).

(14) Using a suitable lifting device, raise generator set, remove 6"x6" blocks, and place 2"x4" blocks under skids of generator set. Lower generator set onto 2"x4" blocks. Ensure blocks are under skids only. Do not remove tension from lifting device.

(15) Slide bottom tray under generator set. Ensure weld nuts are positioned in down position. Weld nuts should be centered on fork lift tunnel holes.

(16) Raise bottom tray assembly, and install keepers, washers, and capscrews to secure one side of bottom tray assembly. (Refer to figure 8-23.)

(17) Raise generator set, and remove 2"x4" blocks. Place a 1"x4" block under bottom tray assembly on other side and slowly lower generator set to push bottom tray assembly into position. Rubber must not bend or be allowed to tear loose when generator set is lowered.

(18) Install keepers, washers, and capscrews to secure the bottom tray assembly. (Refer to figure 8-23.)

(19) Raise generator set, and remove 1"x4" block. Lower generator set and remove lifting device.

#### CAUTION

Do not allow side panel to fall from mounting members or set side panels on threaded studs.

(20) Raise side panel skirt 90° and remove from side panel assembly. Remove screws, capscrews, washers, keepers, and remove upper side panel skirt. (Refer to figure 8-25.) Attach lifting sling, and carefully raise and position side panel assembly on mounting member.

(21) Install three rubber washers, three flatwashers, and three locking nuts supplied with kit in bottom of side panel. Ensure rubber flaps are flat against radiator and are pointed forward. Remove plastic plug and feed oil drain hose through side panel hole. (Refer to figure 8-25.)

(22) Remove lifting sling from side panel.

(23) Repeat steps (20) thru (22) to install other side panel.

**CAUTION**

Do not allow front lower panel to drop or set on ground. Damage to brackets could result.

(24) Position front lower panel assembly on generator set. Ensure top rubber flap is in raised position on radiator shell lip. Remove plastic plugs from rotolock holes. Align male and female rotolocks and, using hex tool, turn rotolocks to secure the front lower panel assembly. (Refer to figure 8-26.) Install plastic plugs. Ensure mounting zee is below bottom tray assembly.

(25) Attach lifting strap, and raise front top panel assembly into position on side panels. Ensure alignment pins fit in holes for proper alignment. Remove plastic plugs from rotolock holes. Align male and female rotolocks and, using hex tool, turn rotolock to secure the front top panel assembly. Remove lifting strap. (Refer to figure 8-26.) Install plastic plugs.

(26) Position exhaust extension on engine exhaust. Install and tighten clamp to secure the exhaust extension. Exhaust extension opening must be pointed down and must not interfere with other components later.

**CAUTION**

Do not allow rear panel assembly to drop or set on ground. Damage to brackets could result

(27) Attach lifting strap and position rear panel assembly on generator set. Ensure alignment pins are in holes for proper alignment. Remove plastic plugs from rotolock holes. Align male and female rotolocks and, using hex tool, turn rotolocks to secure the rear panel assembly. Remove lifting strap. (Refer to figure 8-26.) Install plastic plugs. Ensure mounting zee is below bottom tray assembly.

**NOTE**

Ensure lifting clevises are in the raised position before installing roof panel assembly.

(28) Attach lifting sling to roof panel assembly, and position on generator set. Ensure alignment pins are in holes. It may be necessary to use C-clamps to pull the side panels into position using the lifting clevis as an anchor for the C-clamp. Remove plastic plugs from rotolock holes. Align male and female rotolocks and, using hex tool, turn rotolocks to secure the roof panel assembly. Remove the lifting sling. (Refer to figure 8-26.) Install plastic plugs. Install two sockethead capscrews to secure roof panel assembly.

(29) Raise sealing angle until it contacts roof, and tighten mounting hardware.

(30) Tighten capscrews securing mounting members.

(31) Attach lifting sling to inlet turn assembly, and position on roof assembly. Remove the lifting sling. Remove plastic plugs from rotolock holes. Align male and female rotolocks to secure the inlet turn assembly. (Refer to figure 8-26.) Install plastic plugs.

(32) Attach lifting sling to discharge turn assembly, and position on roof assembly. Remove plastic plugs from rotolock holes. Remove lifting sling. Align male and female rotolocks and, using hex tool, turn rotolocks to secure the discharge turn assembly. (Refer to figure 8-26.) Install plastic plugs.

(33) Position upper side panel skirt on side panel and install screws, washers, keepers, and capscrews.

**NOTE**

Capscrews, keepers, and washers must be moved to end panels to secure side panel skirts.

(34) Install side panel skirts on slip-joint hinges and secure with keepers.

(35) Lower side panel skirts into proper position. Tighten capscrews on keepers.

(36) Ensure inlet door, discharge door, and control panel access door, and access doors are closed.

(37) Reconnect battery cables.

**NOTE**

When bottom panel tray assembly is installed, generator set will require 1-inch ground clearance. Stones, debris, or other material may damage bottom tray assembly. Generator set may not be skidded with bottom panel tray installed.

c. Remove acoustic suppression kit from generator set by reversing installation procedures.

d. If generator set is to be trailer mounted, the following must be performed.

(1) Raise side panel skirts. Connect a copper ground wire to the ground stud. Securely tighten the nut onto the ground stud. Lock-tight or a second nut tightened onto the ground stud may be used to ensure that the nut does not loosen from vibration after installation. The ground wire should be long enough

to reach the trailer ground stud following the generator and trailer frame. Install anti-rotation clips, capscrews, and fiber washers in mounting holes in skid base. Run the ground wire along the skid base towards the front of the trailer. Lower the side skirts and secure the skirts with the skirt clips.

(2) Glue isolators on skid base or surface of trailer. Refer to figure 8-23.

(3) Lower generator set onto the trailer. Run the ground wire along the generator and trailer frames to the trailer ground stud. Connect the ground wire to the trailer ground stud.

(4) Install washers and nuts to secure generator set.

**NOTE**

Do not overtighten nuts. Tighten nuts to 5 ft-lb torque (6.80 N.m), and install jam nuts.

(5) Remove hex nuts, capscrews, and locking pins from trailer platform.

(6) Position trailer brackets, and install capscrews, hex nuts, and locking pins on trailer brackets.



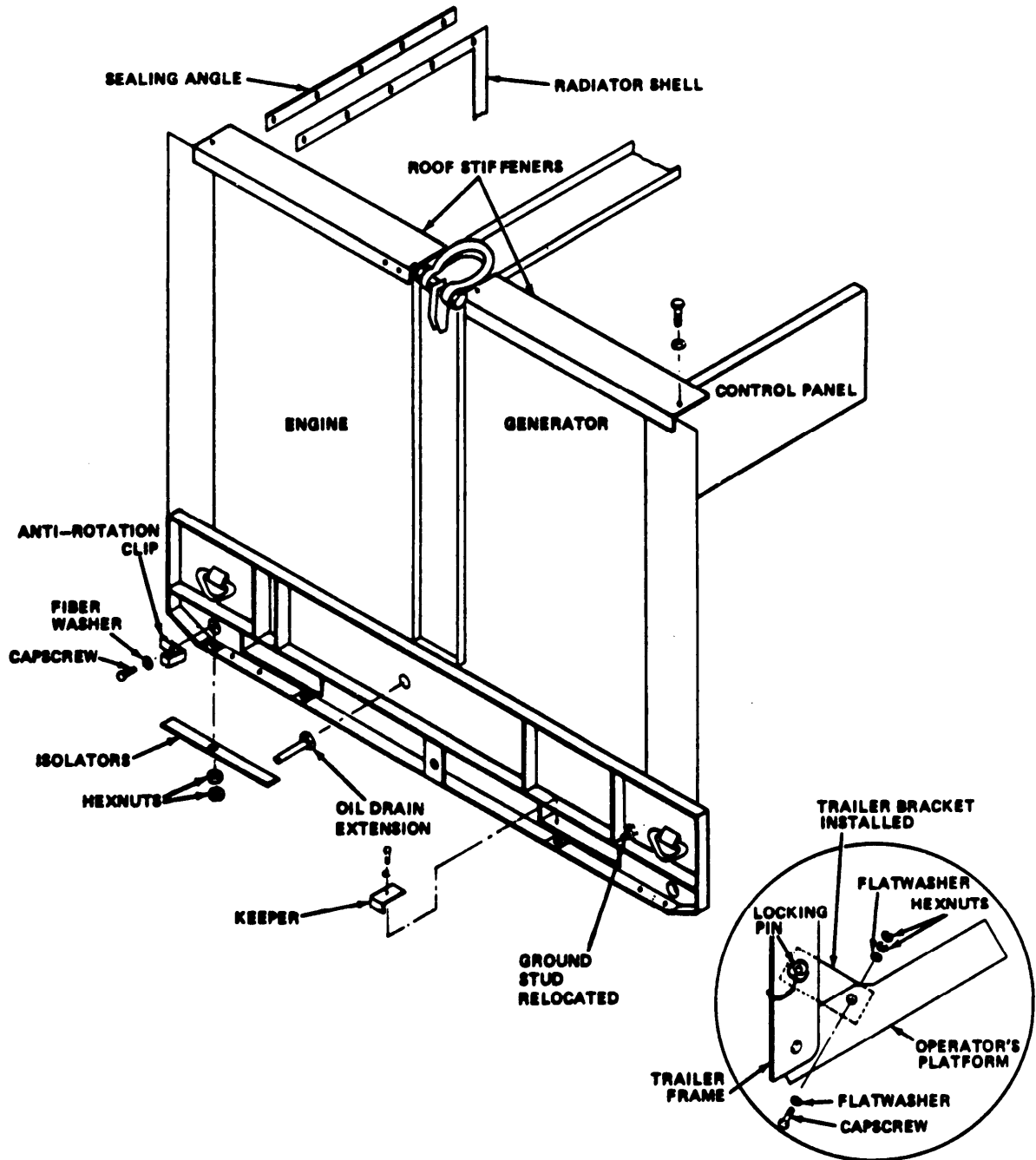

Figure 8-23. Roof Stiffeners, Sealing Angle, Oil Drain, Isolators, Bottom Panel Tray Assembly, and Trailer Brackets

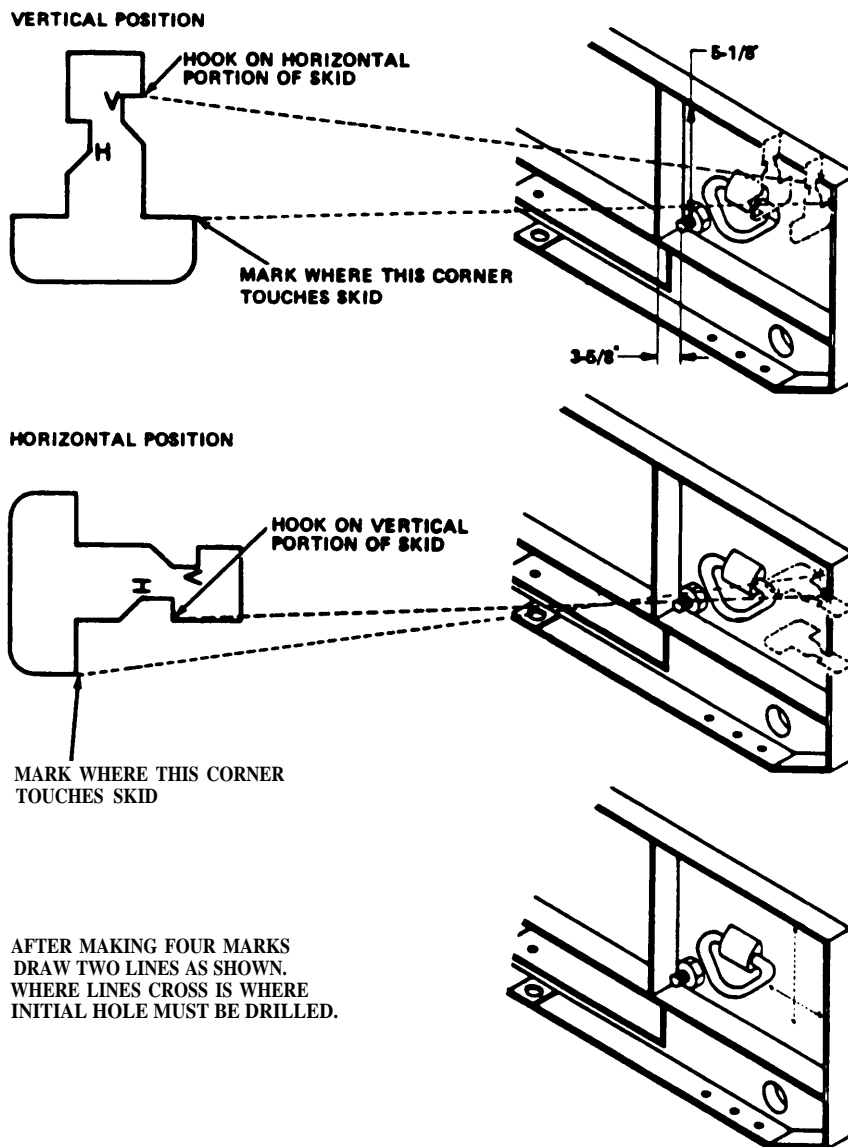
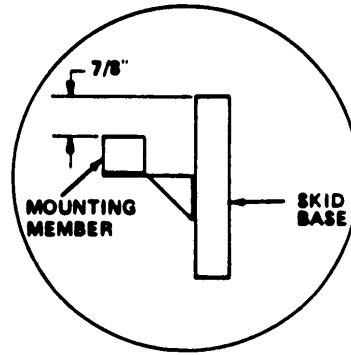

Figure 8-24. Hole Locations on Skid Base



TM 5-6115-465-34  
TO 35C2-3-446-2  
NAVFAC P-8-625-34  
TM 06858B/06859D-34

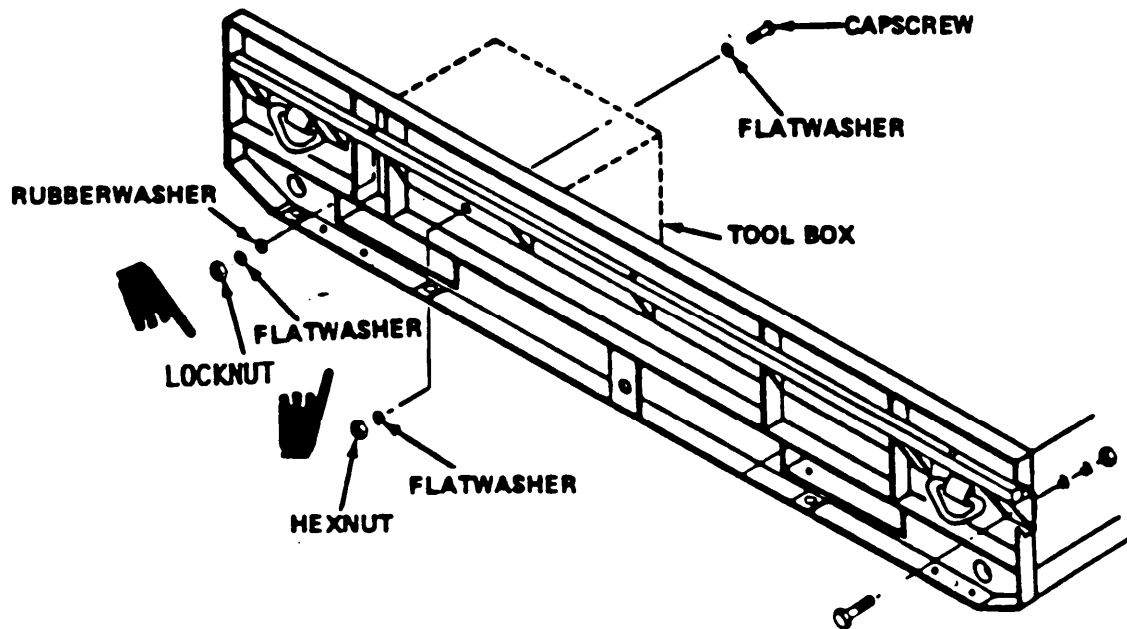

Figure 8-25. Mounting Hardware and Hole Location for Side Panel Assembly

- |                            |                                |
|----------------------------|--------------------------------|
| 1. Discharge Turn Assembly | 9. Isolators                   |
| 2. Inlet Turn Assembly     | 10. Bottom Panel Tray Assembly |
| 3. Roof Panel Assembly     | 11. Front Lower Panel Assembly |
| 4. Rear Panel Assembly     | 12. Front Upper Panel Assembly |
| 5. Side Panel Skirt        | 13. Lifting Strap              |
| 6. Side Panel              | 14. Mounting Zee               |
| 7. Roof Stiffeners         | 15. Socket Head Capscrew       |
| 8. Sealing Angle           | 16. Upper Side Panel Skirt     |
|                            | 17. Document Box               |

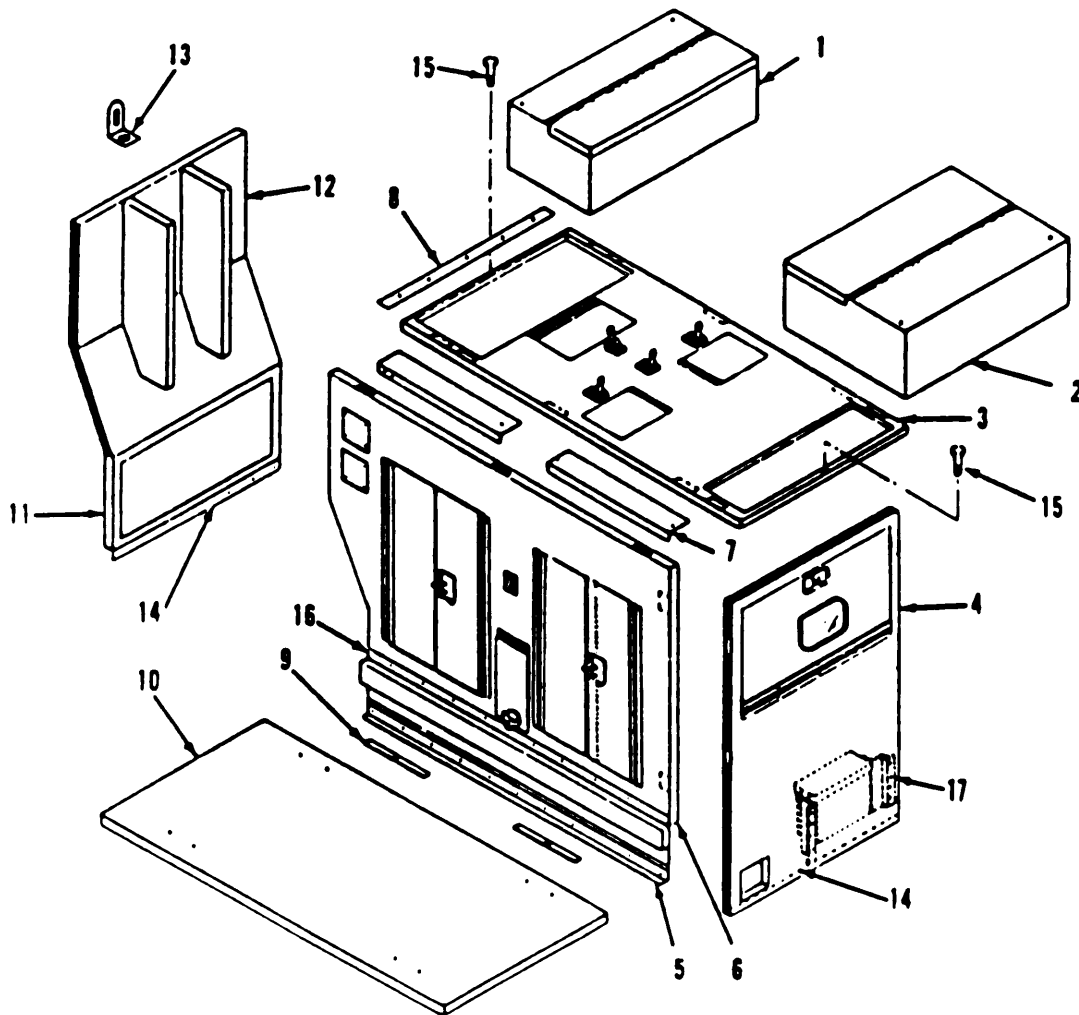

Figure 8-26. Acoustic Suppression Kit Major Components

APPENDIX A

REFERENCES

This Appendix contains a list of reference manuals that may be used in conjunction with this TM in the operation and maintenance of the 15 KW DOD Generator Set. Those manuals not coded are applic-

able for use by all services. The manuals are coded (A),for Army use (F) Air Force use, (N) Navy use, and (M) Marine Corps use.

A-1. FIRE PROTECTION

TB 5-4200-200-10 Hand Portable Fire Extinguishers Approved for Army Users

A-2. LUBRICATION

C9100-IL Identification List for Fuels, Lubricants, Oils and Waxes  
LO 5-6115-464-12 (A) Lubrication Order  
LO 06858B/06858D-12M

A-3. PAINTING

T.O. 35-1-3 (F) Painting and Marking of USAF Aerospace Ground Equipment  
TM 9-213 (A) Painting Instructions for Field Use

A-4. RADIO SUPPRESSION

T.O. 31-1-141-13 (F) Basic Electronics Technology  
TM 11-483 (A) Radio Interference Suppression

A-5. MAINTENANCE.

T.O. 00-25-234 (F) General Shop Practice Requirements for the Repair, Maintenance and Test of Electric Wiring  
T.O. 1-1A-14 (F) Installation Practices for Aircraft Electric and Electronic Wiring  
NAVWEPS 01-1A-505 (N)  
TM 55-1500-323-25 (A)  
T.O. 35-1-11 (F) Organizational, Intermediate and Depot Level Maintenance for FSC 6115 Non-Airborne Equipment  
T.O. 35-1-12 (F) Components and Procedures for Cleaning Aerospace Ground Equipment  
T.O. 35-1-26 (F) Repair/Replacement Criteria for FSC 6115 Aerospace Ground Equipment  
T.O. 35-1-524 (F) USAF Equipment Registration Number System Applicable to FSC 6115 Equipment  
TM 9-1870-1 (A) Care and Maintenance of Pneumatic Tires  
TM 9-2610-200-34 (A) Military Standardization Handbook Generator Sets, Electrical, Measurements and Instrumentations  
T.O. 36Y32-1-142 (F) Use of Anti-freeze Solutions and Cleaning Compounds in Engine Cooling Systems  
TB 750-651 (A) The Army Maintenance Management Systems (TAMMS) Operator and Organizational Maintenance Manual  
DA Pam 738-750 (A)  
TM 5-6115-465-12 (A)  
T.O. 35C2-3-446-1 (F)  
NAVFAC P-8-625-12 (N)  
TM 06858B/06859D-12 (M)  
TM 5-6115-465-24P (A) Organizational, DS, GS and Depot Maintenance Repair Parts and Special Tools List  
T.O. 35C2-3-446-4 (F)  
NAVFAC P-8-624-25P (N)  
SL 4-0685B/06859D (M)  
TM 9-6140-200-15 (A) Operation and Organizational, Field, and Depot Maintenance: Storage  
T.O. 36Y4-1-194 (F) Batteries, Lead Acid Type  
T.O. 34Y19-1-111 (F) Electric Motor and Generator Repair  
TM 5-764 (A)

TM 5-6115-465-34  
T0 35C2-3-446-2  
NAVFAC P-8-625-34  
TM 06858B/06859D-34

A-5. MAINTENANCE (CONT)

TM 5-6115-588-14 (A) Operator, Organizational, Intermediate (Field) (Direct and General  
T.O. 35CA-1-111 (F) Support) and Depot Maintenance Including Repair Parts and Special  
NAVFAC P-8-601 (N) Tools List for Auxiliary Equipment 15 through 200 KW, DOD Family  
TM 6115-15/4 (M) Generator Sets

A-6. SHIPMENT AND STORAGE

T.O. 35-1-4 (F) Processing and Inspection of Aerospace Ground Equipment for Storage  
and Shipment  
T.O. 38-1-5 (F) Processing and Inspection of Non-Mounted, Non-Aircraft Gasoline and  
Diesel Engine for Storage and Shipment  
TB 740-97-2 (A) Preservation of USAMEC Mechanical Equipment for Shipment and Storage  
TM 740-90-1 (A) Administrative Storage of Equipment

A-7. DESTRUCTION OF MATERIAL

TM 750-244-3 (A) Procedures for Destruction of Equipment to Prevent Enemy Use

A-8. RADIOACTIVE MATERIAL

TB 750-248 (A) Instructions for Safe Handling, Maintenance, Storage, and Disposal of  
Radioactive Commodities Managed by U.S. Army Troop Support  
Command

ALPHABETICAL INDEX

Subject	A	Paragraph, Figure, Table, Number
Acoustic suppression kit, general .....		8-24
Acoustic suppression kit major components .....		F8-26
Acoustic suppression kit installation and removal .....		8-25
AC Power control wiring harness .....		4-13
Air cleaner assembly .....		3-44
Axle assemblies .....		8-18
B		
Batteries .....		3-2
Battery charging alternator .....		3-5
Breather and breather tube .....		3-46
C		
Camshaft .....		3-54
Circuit interrupter test (short circuit) .....		7-18
Circuit interrupter test (overload current) .....		7-19
Circuit interrupter test (over voltage and under voltage) .....		7-20
Control box assembly .....		8-21
Control cubicle assembly .....		4-2
Convenience and paralleling receptacles wiring harness .....		5-3
Convenience receptacle and circuit breaker .....		5-2
Coolant lines and fittings .....		8-5,8-12
Coolant pump and motor assembly .....		8-11
Coolant temperature transmitter .....		3-7
Coolant thermostat and housing .....		3-31
Cooling fan .....		3-29
Crankshaft, connecting rods and pistons .....		3-55
Current transformer assemblies .....		5-8
Cylinder block assembly .....		3-56
Cylinder head and rocker arm assembly .....		3-53
D		
Day tank assembly .....		3-18
Day tank fuel level and low fuel cutoff switch .....		3-11
DC control circuit breaker .....		4-5
Demolition to prevent enemy use .....		1-3
Description .....		1-5
Direction of rotation controls .....		7-7
Direct support, general support and depot maintenance .....		2-2
E		
Electrical accessories inspection .....		7-5
Engine assembly, removal and installation .....		2-6
Engine front support .....		3-48
Engine inspection .....		7-3
Engine wiring harness assembly .....		3-13
Exciter control wiring harness .....		4-14
Exciter Stator, Testing .....		5-16.1.a.
Exhaust manifold .....		3-52
Exhaust pipe and muffler .....		3-45
F		
Fabricated tools and equipment .....		2-3
Fault locating indicator .....		4-3
Field flash circuit Components .....		5-16.1
Field flash circuit Testing .....		5-16.1.b.
Fits and tolerances .....		1-8
Flywheel and flywheel housing .....		3-49
Forms and records .....		1-2

ALPHABETICAL INDEX (CONT)

Subject	F (CONT)	Paragraph, Figure, Table, Number
Frequency adjust range test . . . . .		7-16
Frequency and voltage regulation, stability, and transient response (short-term) .		7-15
Fuel injection nozzle holders and lines . . . . .		3-21
Fuel injection pump assembly . . . . .		3-20
Fuel lines . . . . .		3-22
Fuel solenoid valve . . . . .		3-12
Fuel strainer and filter assembly . . . . .		3-17
Fuel transfer pumps . . . . .		3-16
G		
Generator assembly, removal and installation . . . . .		2-7 7-4
Generator inspection . . . . .		5-16
Generator maintenance instructions . . . . .		4-7
Governor control unit . . . . .		4-12
Governor control unit to hydraulic actuator unit wiring harness . . . . .		3-25
Grille . . . . .		
H		
Heater assembly . . . . .		8-4, 8-10
Heater control assembly . . . . .		8-3, 8-9
Housing and frame inspection . . . . .		7-2
Hydraulic actuator unit . . . . .		3-42
Hydraulic pump assembly . . . . .		3-40
Hydraulic sump . . . . .		3-39
Hydraulic system filter <b>assembly</b> . . . . .		3-41
I		
Intake manifold . . . . .		3-51
L		
Lifting frame maintenance . . . . .		6-4
Load bank housing . . . . .		8-22
Load measuring unit . . . . .		4-6
Load measuring unit to tactical relay assembly wiring harness . . . . .		4-11
Load terminal board assembly . . . . .		5-7
Low oil pressure protective device test . . . . .		7-21
Low oil pressure switch . . . . .		3-10
Low oil protective device . . . . .		7-9
Lubrication oil filter . . . . .		3-33
M		
Main fuel tank . . . . .		3-15
Main load contactor . . . . .		5-6
Main load contactor (Effective with serial number RZ70001 and KZ0001 thru KZ02752). . . . .		5-6.1
Malfunction indicator test . . . . .		7-12
Manual speed control . . . . .		4-4
Maximum power test . . . . .		7-24
O		
Oil level gauge . . . . .		3-34
Oil pan assembly . . . . .		3-35
Oil pump assembly . . . . .		3-37
Oil pressure transmitter . . . . .		3-9
Overspeed protective device test . . . . .		7-17

ALPHABETICAL INDEX (CONT)

Subject	O (CONT)	Paragraph, Figure, Table, Number
Overtemperature protective device test	.....	7-22
Overtemperature switch	.....	3-8
P		
Parallel operation provisions (real power)	.....	7-10
Parallel operation provisions (reactive power)	.....	7-11
Phase balance test voltage	.....	7-13
Phase sequence test (rotation)	.....	7-23
Precise relay assembly	.....	5-12
Precise relay assembly to governor control unit wiring harness	.....	4-17
R		
Radiator	.....	3-27
Regulator range test	.....	7-14
Relay table components adjustment	.....	5-14
Replacement of interference suppression component.	.....	5-18
Relay table maintenance	.....	6-2
Reverse power protective device test	.....	7-8
S		
Scope	.....	1-1
Secondary fuel filter assembly	.....	3-19
Shipment and storage	.....	1-4
Shutter assembly	.....	3-28
Shutter control assembly	.....	3-26
Skid base assembly maintenance	.....	6-6
Slave receptacle	.....	3-3
Special relay assembly	.....	5-11
Special relay assembly to control cubicle assembly wiring harness	.....	4-16
Special relay assembly to fault locating indicator wiring harness	.....	4-15
Special relay assembly to precise relay assembly wiring harness	.....	4-18
Special relay assembly to static exciter wiring harness	.....	4-10
Speed switch	.....	3-6
Speed switch (Effective with serial number RZ70001 and KZ00001 thru KZ02752)	.....	3-6.1
Start aid assembly	.....	3-23
Starter assembly	.....	3-4
Starter assembly (Effective with serial number RZ70001 and KZ00001 thru KZ02752)	.....	3-4.1
Static exciter and voltage regulator assembly	.....	5-13
T		
Tabulated data	.....	1-6
Tactical relay assembly	.....	5-10
Tactical relay assembly to special relay assembly wiring harness	.....	4-9
Testing for Electromagnetic interference	.....	5-17
Timing gears and cover	.....	3-50
Tools and support equipment	.....	2-1
Troubleshooting	.....	2-4
Troubleshooting, electric winterization kit	.....	8-8
Troubleshooting, fuel burning winterization kit	.....	8-2
U		
Under frequency protective device test	.....	7-25

ALPHABETICAL INDEX (CONT)

Subject	Paragraph, Figure, Table, Number
V	
Voltage reconnection board assembly . . . . .	5-5
W	
Water pump . . . . .	3-30
Wheel bearings . . . . .	8-17
Wheel mounting kit installation and removal . . . . .	8-15
Wheel and tires . . . . .	8-16
Wiring harness . . . . .	8-13
Wiring harness assembly . . . . .	8-6



**By Order of the Secretaries of the Army, the Navy, and the Air Force:**

Official:

VERNE L. BOWERS  
*Major General, United States Army,  
The Adjutant General.*

FRED C. WEYAND  
*General, United States Army,  
Chief of Staff.*

A. R. MARSCHALL  
*Rear Admiral, CEC, U.S. Navy  
Commander,  
Naval Facilities Engineering Command*

Official:

JACK R. BENSON, *Colonel, USAF  
Director of Administration*

DAVID C. JONES, *General, USAF  
Chief of Staff*

E. J. Miller  
*Major General, U.S. Marine Corps  
Deputy Chief of Staff for Installation & Logistics*

Distribution:

*Active Army:*

To be distributed in accordance with DA Form 12-25D, Direct and General Support maintenance requirements for 30 KW, 60 HZ, Precise Power, and 30 KW, 400 KW, 60 HZ Precise Power.

*Marine Corps: MARCORPS AGC*



RECOMMENDED CHANGES TO EQUIPMENT TECHNICAL PUBLICATIONS



THEN... JOT DOWN THE DOPE ABOUT IT ON THIS FORM. CAREFULLY TEAR IT OUT. FOLD IT AND DROP IT IN THE MAIL!

SOMETHING WRONG WITH THIS PUBLICATION?

FROM (PRINT YOUR UNIT'S COMPLETE ADDRESS)  
 CDR, 1st Br, 65th ADA  
 ATTN: SP4 J. Brown  
 Key West, FL 33040

DATE SENT  
 10 Jun 79

PUBLICATION NUMBER: TM 9-1430-550-34-1

PUBLICATION DATE: 7 Sep 72

PUBLICATION TITLE: Unit of Radar Set AN/MPQ-50 Tested at the HFC

BE EXACT PIN-POINT WHERE IT IS			
PAGE NO	PARA-GRAPH	FIGURE NO	TABLE NO
9-19		9-5	
21-2	step 1C	21-2	

**IN THIS SPACE TELL WHAT IS WRONG AND WHAT SHOULD BE DONE ABOUT IT:**

"B" Ready Relay K11 is shown with two #9 contacts. That contact which is wired to pin 8 of relay K16 should be changed to contact #10.

Reads Multimeter B indicates 600 K ohms to 9000 K ohms.

Change to read: Multimeter B indicates 600 K ohms minimum.

Reason: Circuit being checked could measure infinity. Multimeter can read above 9000 K ohms and still be correct.

TEAR ALONG PERFORATED LINE

SAMPLE

PRINTED NAME GRADE OR TITLE AND TELEPHONE NUMBER  
 SP4 J.T. Brown, Jr.

SIGN HERE  
 SP4 James Brown, Jr.

FILL IN YOUR  
UNITS ADDRESS



FOLD BACK

DEPARTMENT OF THE ARMY

---

---

OFFICIAL BUSINESS

COMMANDER  
U.S. ARMY AVIATION AND TROOP COMMAND  
ATTN: AMSAT-I-MP  
4300 GOODFELLOW BOULEVARD  
ST. LOUIS, MO 63120-1798

TEAR ALONG PERFORATED LINE



FILL IN YOUR  
UNITS ADDRESS



FOLD BACK

DEPARTMENT OF THE ARMY

---

---

OFFICIAL BUSINESS

COMMANDER  
U.S. ARMY AVIATION AND TROOP COMMAND  
ATTN: AMSAT-I-MP  
4300 GOODFELLOW BOULEVARD  
ST. LOUIS, MO 63120-1798

TEAR ALONG PERFORATED LINE



FILL IN YOUR  
UNITS ADDRESS



FOLD BACK

DEPARTMENT OF THE ARMY

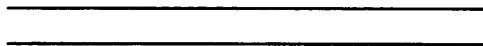

OFFICIAL BUSINESS

COMMANDER  
U.S. ARMY AVIATION AND TROOP COMMAND  
ATTN: AMSAT-I-MP  
4300 GOODFELLOW BOULEVARD  
ST. LOUIS, MO 63120-1798

TEAR ALONG PERFORATED LINE



RECOMMENDED CHANGES TO EQUIPMENT TECHNICAL PUBLICATIONS



THEN... JOT DOWN THE DOPE ABOUT IT ON THIS FORM. CAREFULLY TEAR IT OUT. FOLD IT AND DROP IT IN THE MAIL!

**SOMETHING WRONG WITH THIS PUBLICATION?**

FROM (PRINT YOUR UNIT'S COMPLETE ADDRESS)

DATE SENT

PUBLICATION NUMBER

TM 5-6115-465-34

PUBLICATION DATE

31 JAN 75

PUBLICATION TITLE

GENERATOR SET, DIESEL ENGINE DRIVEN, TACTICAL SKID MTD. 30 KW

BE EXACT PIN-POINT WHERE IT IS

PAGE NO	PARA-GRAPH	FIGURE NO	TABLE NO
---------	------------	-----------	----------

IN THIS SPACE TELL WHAT IS WRONG AND WHAT SHOULD BE DONE ABOUT IT:

PRINTED NAME GRADE OR TITLE AND TELEPHONE NUMBER

SIGN HERE

FILL IN YOUR  
UNITS ADDRESS



FOLD BACK

DEPARTMENT OF THE ARMY

---

---

OFFICIAL BUSINESS

COMMANDER  
U.S. ARMY AVIATION AND TROOP COMMAND  
ATTN: AMSAT-I-MP  
4300 GOODFELLOW BOULEVARD  
ST. LOUIS, MO 63120-1798

TEAR ALONG PERFORATED LINE



**PIN: 013547-000**