

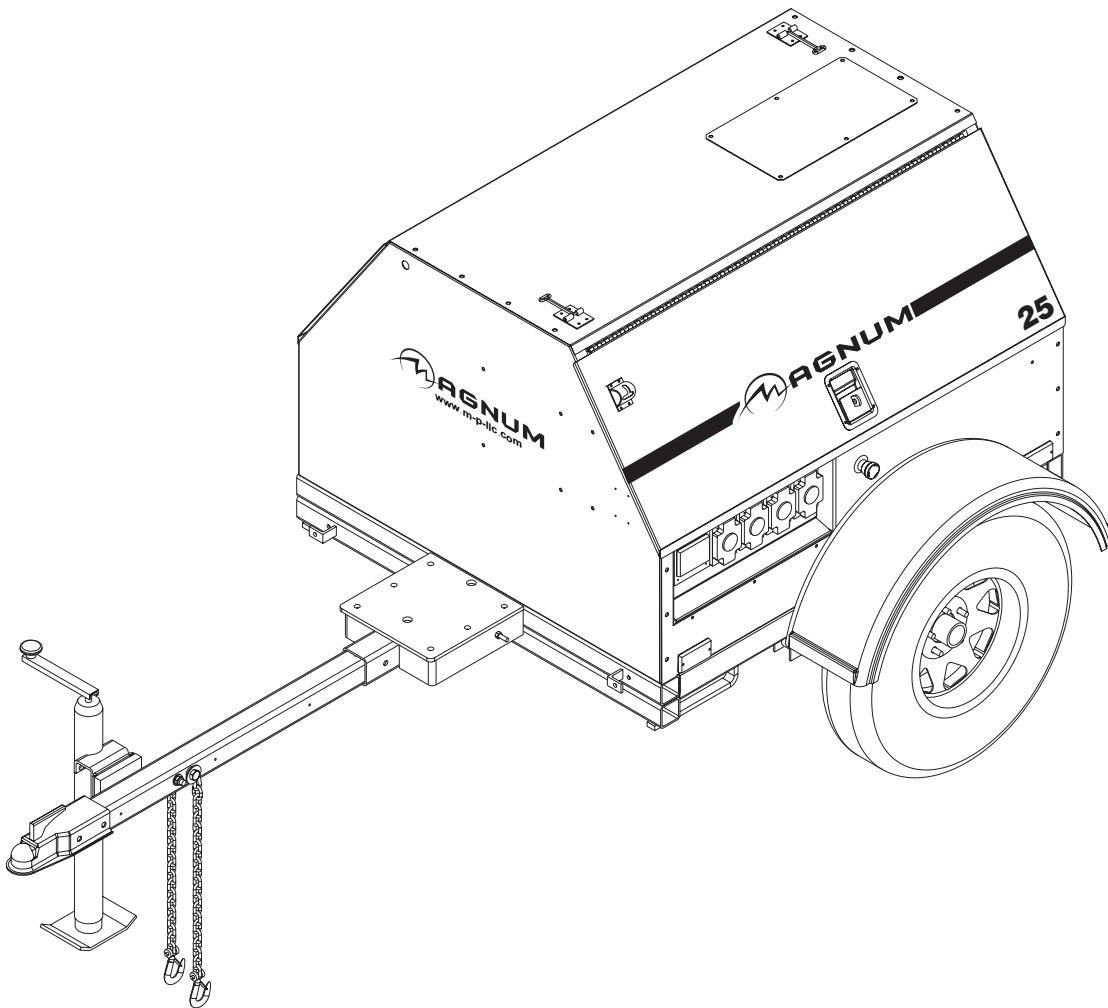

DIESEL GENERATOR MLG 25



OPERATION/PARTS MANUAL

This manual provides information and procedures to safely operate and maintain the generator. For your own safety and protection from physical injury, carefully read, understand, and observe the safety instructions described in this manual. THE INFORMATION CONTAINED IN THIS MANUAL IS BASED ON MACHINES IN PRODUCTION AT THE TIME OF PUBLICATION. MAGNUM PRODUCTS LLC RESERVES THE RIGHT TO CHANGE ANY PORTION OF THIS INFORMATION WITHOUT NOTICE.

An engine operators manual was supplied with the machine at the time of its shipment from the factory. The manual provides detailed operation and maintenance procedures for the engine. Additional copies of this manual are available from the engine manufacturer.

**MAGNUM PRODUCTS LLC
215 POWER DRIVE
BERLIN, WI 54923**

**PHONE: 920-361-4442
FAX: 920-361-4416
TOLL FREE: 1-800-926-9768**

www.m-p-llc.com

Engine Make: _____
Engine Serial #: _____
Engine Model #: _____
Generator Make: _____
Generator Model #: _____
Generator Serial #: _____
Unit Model #: _____
Unit Serial #: _____

TABLE OF CONTENTS

TABLE OF CONTENTS	PAGE 3
SAFETY NOTES	PAGE 4
UNIT SERIAL PLATE LOCATION	PAGE 4
SAFETY NOTES	PAGES 5 - 6
SPECIFICATIONS	PAGE 7
EXTERIOR LOCATIONS	PAGE 8
MAIN CONTROL PANEL	PAGE 9
ENGINE CONTROLLER FEATURES	PAGES 10 - 11
GENERATOR AND ENGINE MONITORING	PAGE 12
GENERATOR OUTPUT CONNECTION LUGS	PAGE 13
VOLTAGE SELECTOR SWITCH	PAGE 14
AUXILIARY OUTLETS	PAGE 15
VOLTAGE REGULATOR	PAGE 15
FINE VOLTAGE ADJUSTMENT	PAGE 15
EMERGENCY STOP SWITCH	PAGE 15
MAIN CIRCUIT BREAKER	PAGE 16
REMOTE START TERMINAL BLOCK	PAGES 16 - 17
GENERATOR STARTING	PAGES 18 - 20
REMOTE STARTING	PAGE 20
SHUTTING DOWN	PAGE 20
EZ-1 CONTROLLER INFORMATION DISPLAYS	PAGE 20
CONTROLLER ALARM LIST WITH DESCRIPTIONS	PAGES 21 - 22
TROUBLESHOOTING AUTO SHUTDOWN CONDITIONS	PAGES 22 - 23
TOWING THE TRAILER	PAGE 23
TRAILER WHEEL BEARINGS	PAGE 23
ENGINE AND GENERATOR MAINTENANCE	PAGE 24
RELOADING THE TIME TO SERVICE REMINDER	PAGE 24
ADJUSTING DISPLAY BACKLIGHTING	PAGE 24
DAILY MAINTENANCE CHECKS	PAGE 25
DERATING FOR ALTITUDE	PAGE 25
FRAME ASSEMBLY	PAGES 26 - 27
ENCLOSURE ASSEMBLY	PAGES 28 - 29
AUXILIARY OUTLET PANEL ASSEMBLY	PAGES 30 - 31
AUXILIARY OUTLET PANEL OPTIONS	PAGES 32 - 33
ENGINE COOLING ASSEMBLY	PAGES 34 - 35
ENGINE ASSEMBLY	PAGES 36 - 37
CONTROL PANEL ASSEMBLY - OLD STYLE	PAGES 38 - 39
CONTROL PANEL ASSEMBLY - NEW STYLE	PAGES 40 - 41
CONTROL BOX ASSEMBLY - OLD STYLE	PAGES 42 - 43
CONTROL BOX ASSEMBLY - NEW STYLE	PAGES 44 - 45
LUG DOOR ASSEMBLY	PAGE 46
GENERATOR ASSEMBLY	PAGE 47
WIRING DIAGRAMS	PAGES 48 - 51

SAFETY NOTES

This manual contains NOTES, CAUTIONS and WARNINGS which must be followed to prevent the possibility of improper service, damage to the equipment, or personal injury. The following formatting options will apply when calling the readers attention to the NOTES, CAUTIONS and WARNINGS.

Notes: Notes contain additional information important to a procedure. The notes called out in this manual will be included in the regular text body but the word “Note” will be in **BOLD text** and the note will be written in italics to make them more visible. For example: **Note:** *Check the engine oil level before starting.*

CAUTION: Cautions provide information important to prevent errors which could damage the equipment. The cautions called out in this manual will be in **BOLD text**, in a separate paragraph or sentence from the regular text body. For example:

CAUTION! Always switch all circuit breakers to “OFF” to prevent the starting of the generator under load.

WARNINGS: Warnings describe conditions or practices which could lead to serious personal injury or death to the operator or others around the equipment. Warnings called out in this manual will be in a separate paragraph, centered and surrounded by a black border, with warning in **BOLD text**. For example:

WARNING!

Only a qualified electrician may service or make connections to the generator. Lethal voltage is present at the connection lugs when the generator is running!

UNIT SERIAL PLATE LOCATION

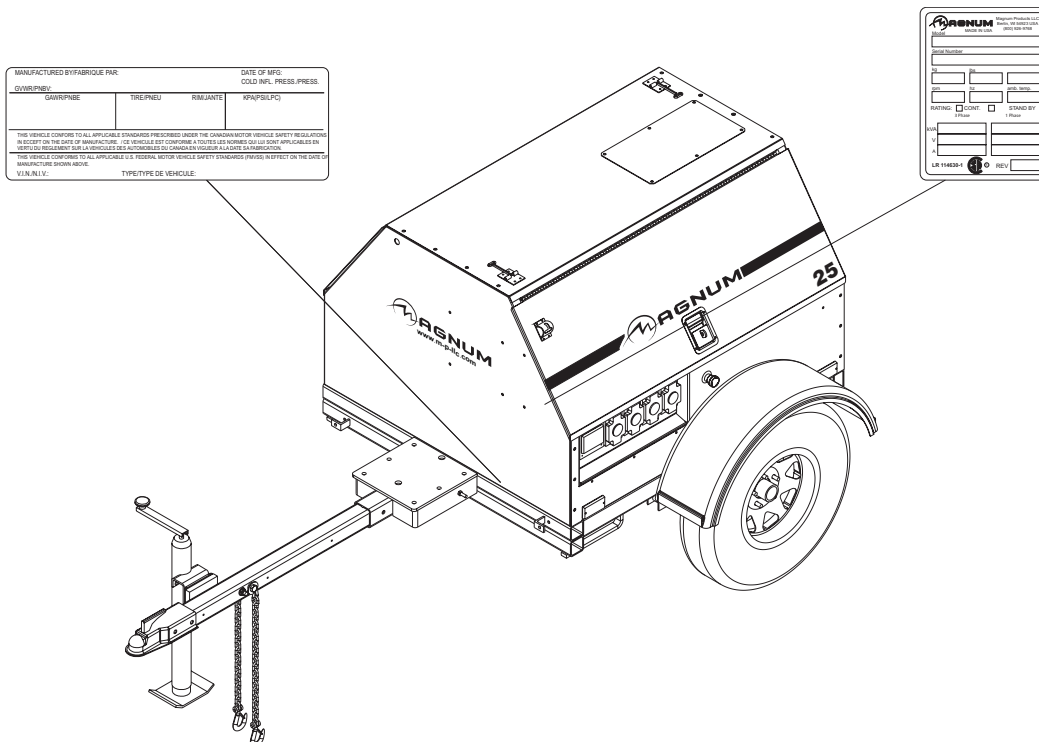

OPERATING SAFETY

Before using the generator be sure you read and understand all instructions! Equipment operated improperly or by untrained personnel can be dangerous! Read the operating instructions and familiarize yourself with the location and proper use of all instruments and controls. Inexperienced operators should receive instruction from someone familiar with the equipment before being allowed to operate or set up the generator.

- The area immediately surrounding the generator should be clean, neat, and free of debris.
- Position and operate generator tower on a firm, level surface.
- NEVER start a unit in need of repair.
- NEVER modify the generator or use it in a manner other than what it was designed for.
- ALWAYS keep the generator doors closed when the engine is running. Do not start the generator if any panels or guards are loose or missing.
- ALWAYS connect the generator to a good earthen ground.
- Move the generator main circuit breaker to the "OFF" position when servicing or troubleshooting the unit.
- The output voltage of the generator can cause a fatal electric shock. Avoid contact with any alternating current wiring when the engine is running. Make sure any extension cords or equipment connected to the convenience outlets are in good working condition.
- NEVER remove control box cover when the engine is running. Exposed live electrical terminals can cause a fatal electrical shock.
- Check your electrical requirements before installing or starting the generator.
- Use a ground fault circuit interrupter (GFCI) in damp or highly conductive areas and construction sites to prevent electrical shock.

ENGINE SAFETY

Internal combustion engines present special hazards during operation and fueling! Failure to follow the safety guidelines described below could result in severe injury or death. Also read and follow all safety warnings described in the Engine Operator's Manual. A copy of this manual was supplied with unit when it was shipped from the factory.

- DO NOT run engine indoors or in an area with poor ventilation unless exhaust hoses are used.
- DO NOT fill fuel tank near an open flame, while smoking, or while engine is running.
- DO NOT fill tank in an enclosed area with poor ventilation.
- DO NOT touch or lean against hot exhaust pipes or engine cylinder.
- DO NOT operate with the fuel tank cap loose or missing.
- DO NOT remove engine coolant cap while engine is hot.
- DO NOT clean air filter with gasoline or other types of low flash point solvents.
- Keep area around exhaust pipes and air ducts free of debris to reduce the chance of an accidental fire.
- Shut the engine down if any of the following conditions exist during operation:
 - A. Noticeable change in engine speed.
 - B. Loss of electrical output.
 - C. Equipment connected to the generator overheats.
 - D. Sparking occurs.
 - E. Engine misfires or there is excessive engine/generator vibration.

TOWING SAFETY

Towing a trailer requires care! Both the trailer and vehicle must be in good condition and securely fastened to each other to reduce the possibility of an accident. Also, some states require that large trailers be registered and licensed. Contact your local Department of Transportation office to check on license requirements for your particular unit.

- Check that the hitch and coupling on the towing vehicle are rated equal to, or greater than, the trailer's "gross vehicle weight rating" (GVWR). Check tires on trailer for tread wear, inflation, and condition.
- Inspect the hitch and coupling for wear or damage. DO NOT tow trailer using defective parts!
- Make sure the trailer hitch and the coupling are compatible. Make sure the coupling is securely fastened to the vehicle.
- Connect safety chains in a crossing pattern under the tongue and attach the brake away cable TO THE REAR BUMPER OF THE TOWING VEHICLE.
- Make sure directional and brake lights on the trailer are connected and working properly.
- Check that lug nuts holding wheels are tight and that none are missing.
- Maximum recommended speed for highway towing is 45 m.p.h.. Recommended off-road towing speed is not to exceed 10 m.p.h. or less depending on terrain.

When towing, maintain extra space between vehicles and avoid soft shoulders, curbs and sudden lane changes. If you have not pulled a trailer before, practice turning, stopping, and backing up in an area away from heavy traffic.

A film of grease on the coupler will extend coupler life and eliminate squeaking. Wipe the coupler clean and apply fresh grease each time the trailer is towed.

REPORTING TRAILER SAFETY DEFECTS

If you believe your trailer has a defect which could cause a crash or could cause injury or death, you should immediately inform the National Highway Traffic Safety Administration (NHTSA) in addition to notifying Magnum Products LLC. If NHTSA receives similar complaints, it may open an investigation; and if it finds that a safety defect exists in a group of vehicles it may order a recall and remedy campaign. However, NHTSA cannot become involved in individual problem between you, your dealer, or Magnum Products LLC.

To contact NHTSA, you may either call the Auto Safety Hotline toll-free at 1-888-327-4236 or by fax at: (202)-366-7882. Additional contact information can be found at: www.nhtsa.dot.gov.

SERVICE SAFETY

This unit uses high voltage circuits capable of causing serious injury or death. Only a qualified electrician should troubleshoot or repair electrical problems occurring in this equipment.

- Before servicing the generator, make sure engine start switch is turned to OFF, circuit breakers are open (off) and the negative terminal on the battery is disconnected. Open main circuit breaker before disconnecting battery cables. NEVER perform even routine service (oil/filter changes, cleaning, etc.) unless all electrical components are shut down.
- NEVER allow water to accumulate around the base of the generator. If water is present, DO NOT service!
- NEVER service electrical components if clothing or skin is wet. If the unit is stored outside, check the engine and generator for any moisture and dry the unit before use.
- NEVER wash the unit with a power washer or high pressure hose.
- Keep hands, feet, and loose clothing away from moving parts on generator and engine.
- Replace all guards and safety devices immediately after servicing.
- Replace all missing and hard-to-read labels. Labels provide important operating instructions and warn of dangers and hazards.
- Make sure slings, chains, hooks, ramps, jacks, and other types of lifting devices are attached securely and have enough weight-bearing capacity to lift or hold the equipment safely. Always remain aware of the position of other people around you when lifting the equipment.

SPECIFICATIONS

Engine manufacturer	ISUZU
Engine model	4LE1-PV 05
Engine type	Diesel, 4-cyl, liquid cooled 4-stroke
Engine horsepower (standby)	34.5 hp (25.7 Kw) @ 1800 RPM
Engine horsepower (primed)	31.5 hp (23.5 Kw) @ 1800 RPM
Fuel tank capacity	56 gal. (215.8 L)
Fuel consumption	2.1 gph (7.90 Lph)
Generator manufacturer	Marathon Electric
Generator model	282NSL1505
Generator output 3O Standby Kw/Kva	20/25
Generator output 1O Standby Kw/Kva	16/16
Generator output 3O Prime Kw/Kva	18/23
Generator output 1O Prime Kw/Kva	15/15
Generator frequency	60 Hz
Generator output voltage 3O	208/220/440/480V
Generator output voltage 1O	120/138/208/220/240/277V
Generator output Amperes 3O (480/208)	30/69
Generator output Amperes 1O (240)	67
Generator power factor	0.8
Generator insulation	Class "H1"
Width	67 in. (170.2 cm)
Weight (no fuel)	1570 lbs (710 kg)
Weight with fuel (approx.)	2000 lbs. (910 kg)
Height	56 in. (142.2 cm)

EXTERIOR LOCATIONS

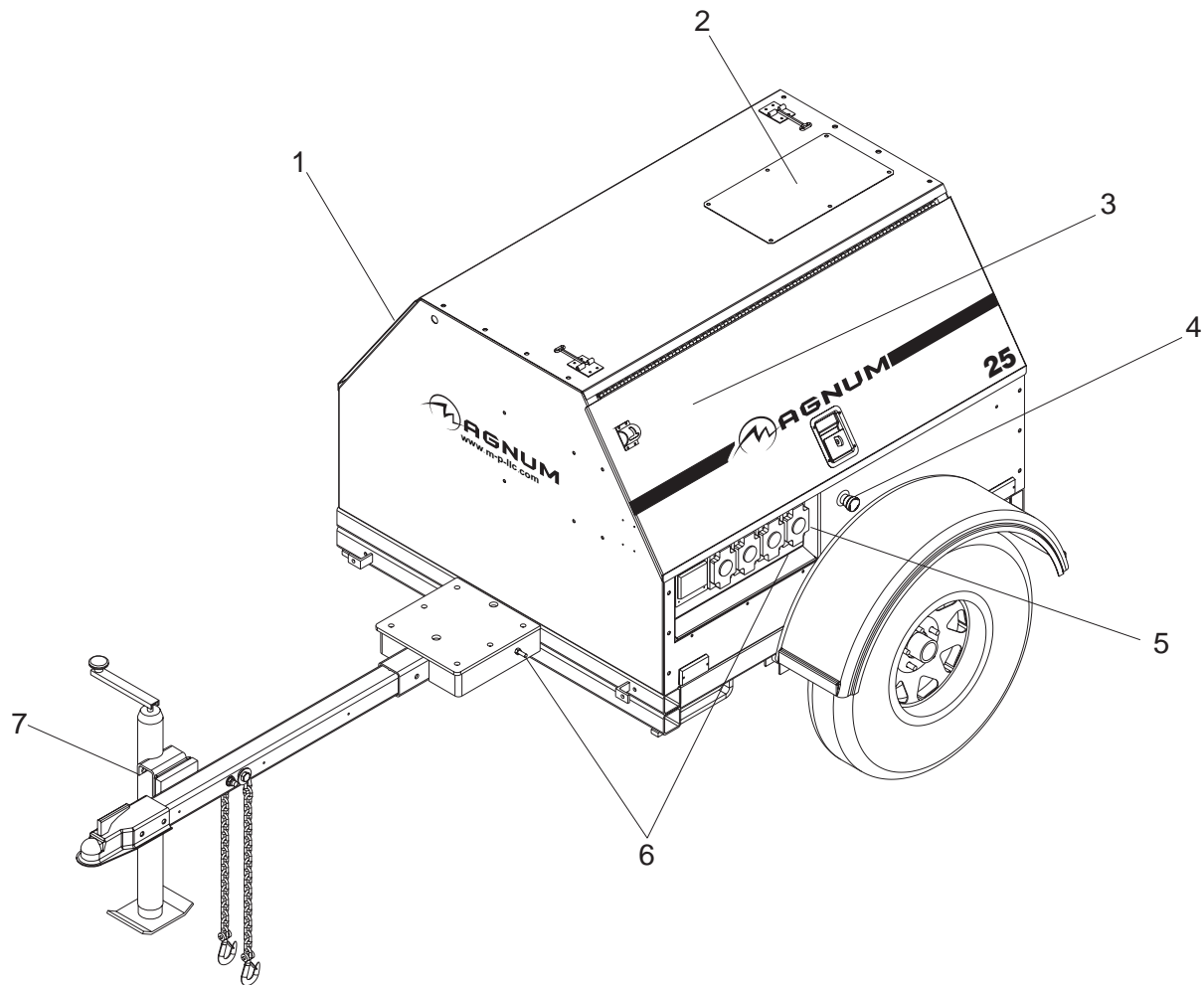

1. FUEL FILLER LOCATION (under door): Use clean **DIESEL FUEL ONLY**.
2. RADIATOR ACCESS PANEL: Remove this panel for engine coolant service.
3. CONTROL PANEL LOCATION (under door): Engine/generator controls and all circuit breakers.
4. EMERGENCY STOP SWITCH: For emergency shutdown; stops engine and trips main circuit breaker.
5. EQUIPMENT OUTLETS: Circuit breaker protected outlets; 20, 30 and/or 50 amp ratings.
6. GROUND STUDS (2): For grounding generator and equipment connected to the equipment outlets.
7. TONGUE JACK: Used to level generator before starting.

MAIN CONTROL PANEL

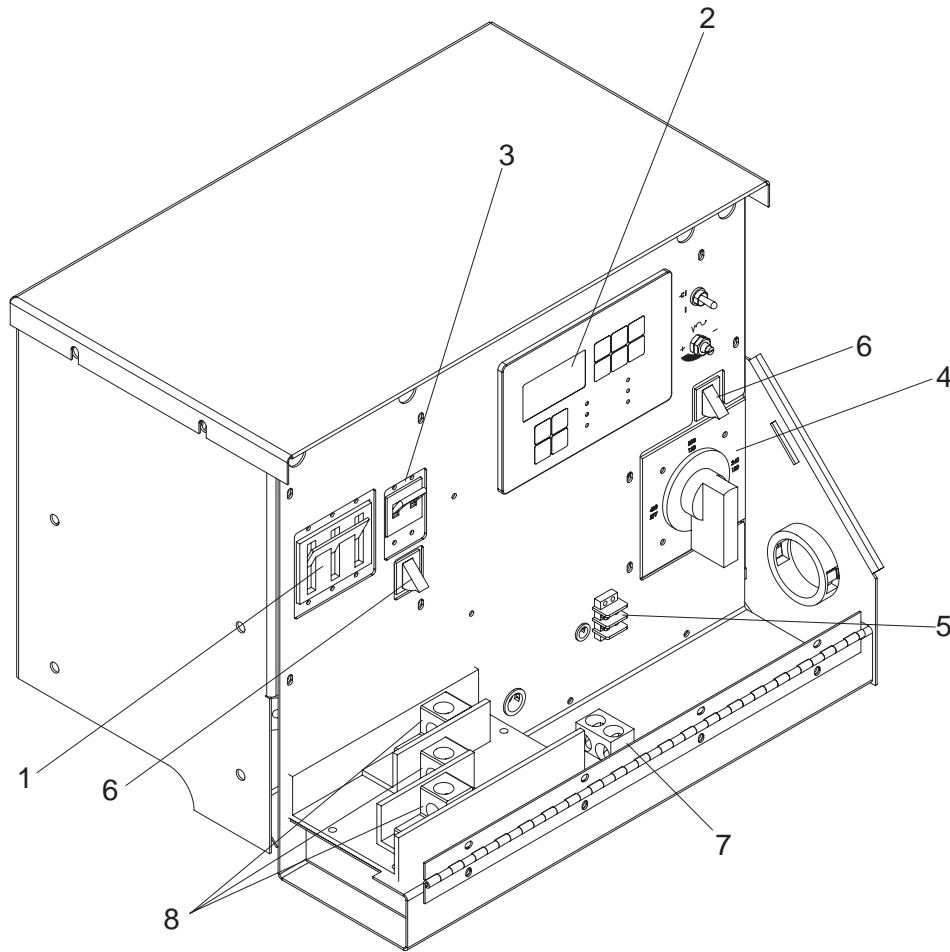

1. **MAIN CIRCUIT BREAKER (90A):** This breaker will disconnect power to the connection lugs.
2. **ENGINE CONTROLLER PANEL:** See pages 10 - 11 for additional information.
3. **AUXILIARY OUTLET MAIN CIRCUIT BREAKER (100A):** This breaker disconnects power to the auxiliary equipment outlets.
4. **PHASE SELECTOR SWITCH:** This switch will change the generator output between three phase and single phase power. See the "VOLTAGE SELECTOR SWITCH" section for more information.
5. **REMOTE START TERMINAL BLOCK:** Allows for remote starting of the generator.
6. **LUG DOOR SAFETY SWITCHES:** These switches will shut the generator down if the lug door is opened when the generator is running.
7. **GENERATOR GROUND CONNECTION LUG:** This lug is for connecting a good earthen ground per any local, state or National Electric Code (NEC) guidelines before starting the generator.
8. **GENERATOR OUTPUT CONNECTION LUGS:** These allow appropriate loads to be wired directly to the generator.

ENGINE CONTROLLER FEATURES

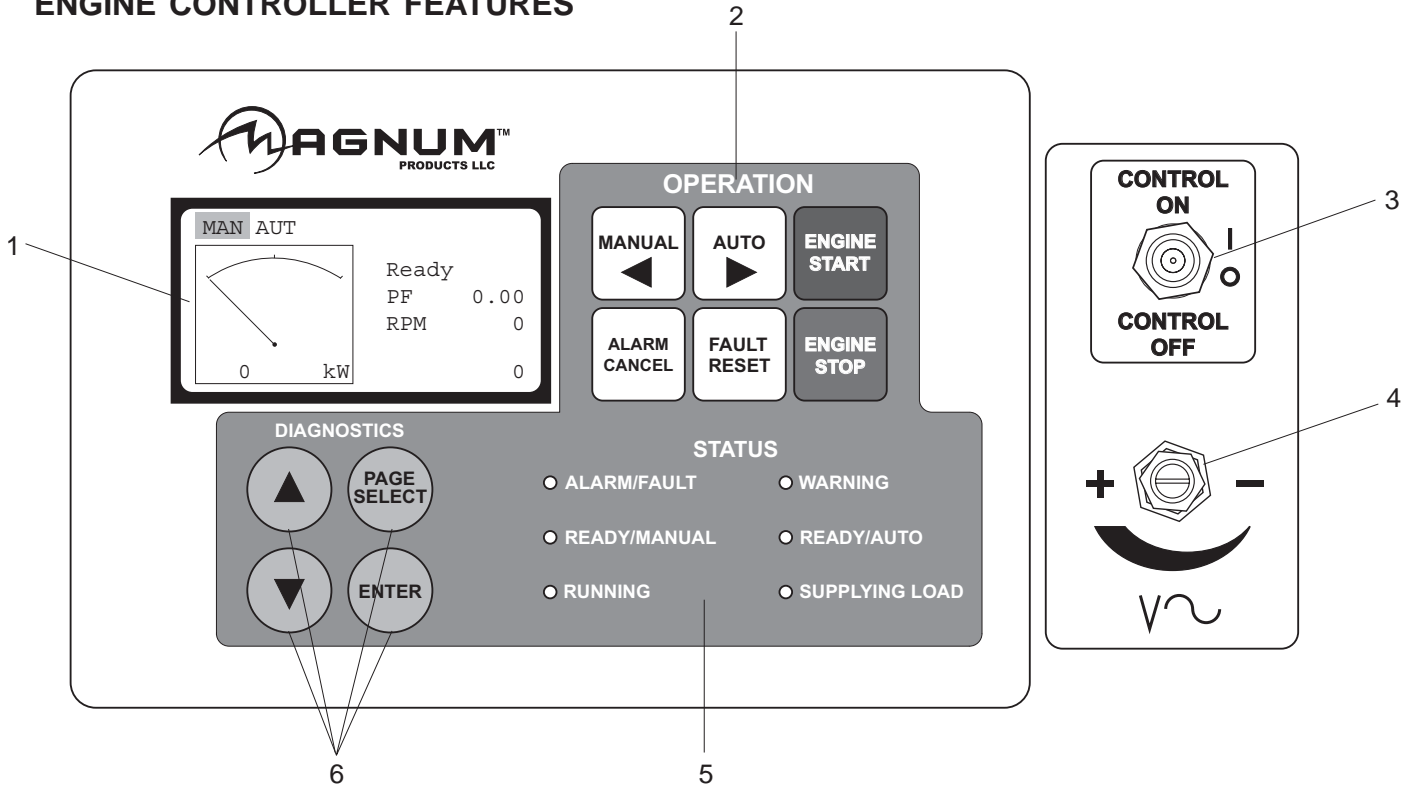

1. LCD DISPLAY

This display shows the controller status in, MANUAL and AUTO (remote start) modes.

Should a shut down fault occur, the LCD display will show the condition causing the fault. At the same time, the engine will shut down and lock out.

The LCD display will also show any possible Engine Sender Failures and Time To Service information. These conditions will not shut down the engine; they are used to alert the operator.

2. OPERATION KEYS

- ◀ MANUAL Press to switch from AUTO to MANUAL mode.
- ▶ AUTO Press to switch from MANUAL to AUTO mode for remote starting of generator.
- ENGINE START Press to start engine.
- ALARM CANCEL Press to cancel alarms (visual or audio if equipped).
- FAULT RESET Press to clear ALARM LIST fault codes.
- ENGINE STOP Press to stop engine.

3. CONTROL POWER SWITCH

This main power switch turns the controller on and off.

4. VOLTAGE ADJUSTMENT RHEOSTAT

This knob allows the end user to fine adjust the output voltage from the generator.

5. OPERATION STATUS LED'S

- ALARM / FAULT Indicates active or inactive alarms.
- READY / MANUAL Indicates controller is in MANUAL mode, ready to start.
- RUNNING Indicates running engine.
- WARNING Indicates active or inactive warnings.
- READY/AUTO Indicates controller is in AUTO mode, ready for remote start signal.
- SUPPLYING LOAD Indicates the genset is running, giving proper voltage and frequency and is supplying load.

6. DIAGNOSTICS

▲ UP

▼ DOWN

Switch between:

POWER SCREEN DISPLAY (DISPLAYS FROM MANUAL TO AUTO MODE)

ALARM SCREEN DISPLAY

HOUR SCREEN DISPLAY

POWER DETAIL SCREEN DISPLAY

Note: Automatically returns to flipping between the ENGINE / GENERATOR DISPLAY SCREENS after 60 seconds.

PAGE SELECT Provides access to programming and resets.

ENTER Allows access to the next level.

GENERATOR MONITORING

Generator information is shown on the LCD display in a repeating manner while the unit is running in MANUAL or AUTO mode. Generator information will show the voltage, amperage and frequency of each phase.

Additional information can be viewed when the unit is MANUAL or AUTO modes. Pressing "PAGE SELECT" then "UP" or "DOWN" on the key pad will display, Alarm Screen, Hour Screen, and Power Detail Screen displays.

NOTE: When loading the generator it is important to observe the amperage to determine the load balance on each line of the generator. Minor load unbalances, usually 5% or less, will not cause any particular problems. Every effort should be made to distribute the load equally between all lines.

1. **PHASE** - Indicates generator configuration, 3 phase or single phase.
2. **HERTZ** - Displays output frequency.
3. **NOMINAL VOLTS** - Displays generator nominal voltage in current phase switch selection.
4. **NOMINAL AMPS** - Displays maximum amps in current phase switch selection.
5. **GENERATOR OUTPUT VOLTAGE** - Line to Line display.
6. **AMPS** - Displays the AC output amperage produced by the generator.
7. **GENERATOR OUTPUT VOLTAGE** - Line to Neutral display.

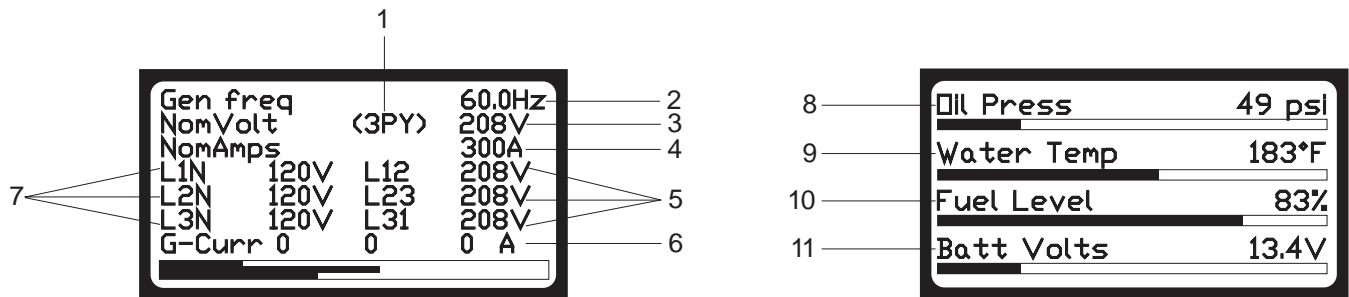

ENGINE MONITORING

Engine information is shown on the LCD display in a repeating manner while the unit is in MANUAL or AUTO mode. Engine information will show the oil pressure, water temperature, fuel level and battery voltage.

8. **OIL** - Displays engine oil pressure. The display registers oil pressure between 0-100 psi. Normal operating pressure is between 35-80 psi.
9. **TEMPERATURE** - Displays the temperature of the engine's coolant. If the coolant temperature exceeds the Max Water Temp the engine will automatically shut down. Zero "0" will be displayed until a minimum of 100° F is reached.
10. **FUEL** - Displays the relative fuel level in the fuel tank in percent (50% = 1/2 tank, 75% - 3/4 tank, etc.). If the fuel level drops below a programmed Fuel Shutdown Percent the engine will automatically shut down.
11. **BATTERY** - Displays the engine battery voltage. A normal reading is 13-14V on 12 volt systems and 24-26V on 24 volt systems.

GENERATOR OUTPUT CONNECTION LUGS

The generator is equipped with connection lugs behind a door below the controller face. The lugs provide connection points for attachment of external loads to the generator. A large decal on the inside of the connection lug door details the proper connections for selected voltages.

WARNING!

It is **HIGHLY RECOMMENDED** that only a trained and licensed electrician perform any wiring and related connections to the generator. Installation should be in compliance with the **NATIONAL ELECTRIC CODE (NEC)** as well as any local or state guidelines as required by law. Failure to follow proper installation requirements may result in equipment or property damage, personal injury or death.

WARNING!

Before any connections are made to the generator, make sure that the main circuit breaker and the control power switch are in the **OFF "O"** position. Potentially lethal voltages may be present at the generator connection lugs.

WARNING!

Improper or incorrect connections to a buildings electrical system can cause potentially lethal voltages to backfeed onto utility lines. This may result in injury or electrocution to utility workers nearby. Make sure the generator is supplying power to an isolated object or building that is not connected to any utility lines.

Connections to the lugs should be made by running the power cables through the circular plastic bushing on the lower right side of the control box. **DO NOT** make any connections directly to the lug without routing the cables through this bushing. The connection lug door is equipped with a safety interlock switch that will automatically trip the main circuit breaker and disable the voltage regulator when the lug door is opened. Use a 5/16" hex-wrench to tighten the cable connections.

A ground connection is located next to the connection lugs. The unit **MUST HAVE** this ground lug connected to a good earthen ground for proper operating safety. The ground connection **SHOULD BE IN COMPLIANCE WITH THE NATIONAL ELECTRIC CODE (NEC) AS WELL AS ANY STATE OR LOCAL GUIDELINES OR CODES.**

VOLTAGE SELECTOR SWITCH

The voltage selector switch is located on a panel attached to the generator behind the door located next to the fuel tank filler. The selector switch is a three position switch that mechanically changes the connections between the generator output leads and the connection lugs on the main control panel. Voltage ranges are selected by rotating the handle on the switch to the desired voltage.

WARNING!

NEVER CHANGE THE VOLTAGE SELECTOR SWITCH WHILE THE ENGINE IS RUNNING! THIS WILL CAUSE SEVERE ARCING AND DAMAGE TO THE SWITCH AND GENERATOR WINDINGS.

480/277V
3-PHASE

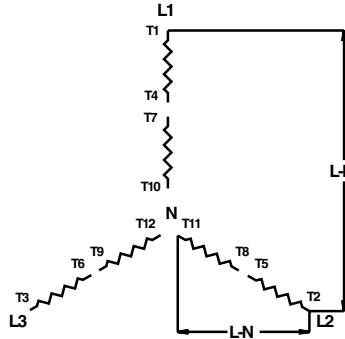
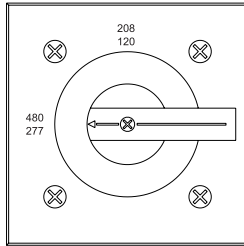

L1 - L2 = 480V L1 - N = 277V
 L2 - L3 = 480V L2 - N = 277V
 L3 - L1 = 480V L3 - N = 277V
 N =

208/120V
3-PHASE

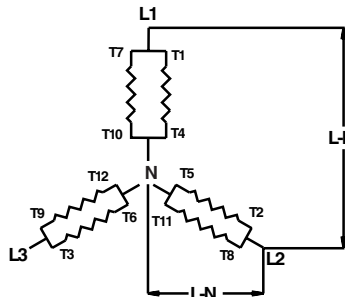
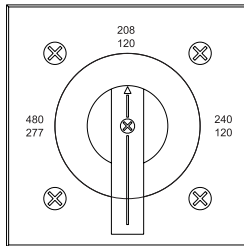

L1 - L2 = 208V L1 - N = 120V
 L2 - L3 = 208V L2 - N = 120V
 L3 - L1 = 208V L3 - N = 120V
 N =

240/120V
1-PHASE

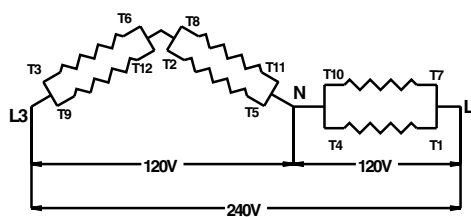
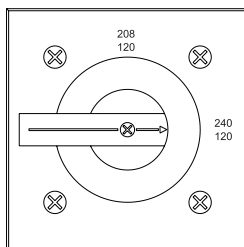

L1 - L3 = 240V L2 - N = -----
 L1 - N = 120V L3 - N = 120V

The voltage switch is equipped with a locking mechanism. Once the proper voltage has been selected, push the red latch on the inside of the phase switch handle up and insert a padlock through the handle. By locking the handle in place you will prevent unauthorized personnel from changing the switch settings.

NOTE: When the voltage selector switch is in position for 480/277V 3Ø, voltage at the two GFCI duplex convenience outlets is 139 Volts and the voltage at the three twist-lock outlets is 240/139 Volts. When the voltage selector switch is in position for 208/120V 3Ø, voltage at the three twist-lock outlets and the two GFCI outlets is 208/120 volts.

AUXILIARY OUTLETS

The control panel is equipped with six outlets for running accessories or tools from the generator. Power is supplied to the outlets any time the engine is running and the main circuit breaker and the auxiliary outlet main circuit breaker are switched on “I”.

Should the main breaker trip, or the auxiliary outlet main circuit breaker trip, remove some of the load to the outlets before turning them back on.

Note: To ensure proper grounding, anytime the generator is providing power to any equipment or load panels that do not have a grounded plug a ground wire **must be** added between the equipment and the grounding stud on the outlet panel per any local, state or NEC codes and guidelines.

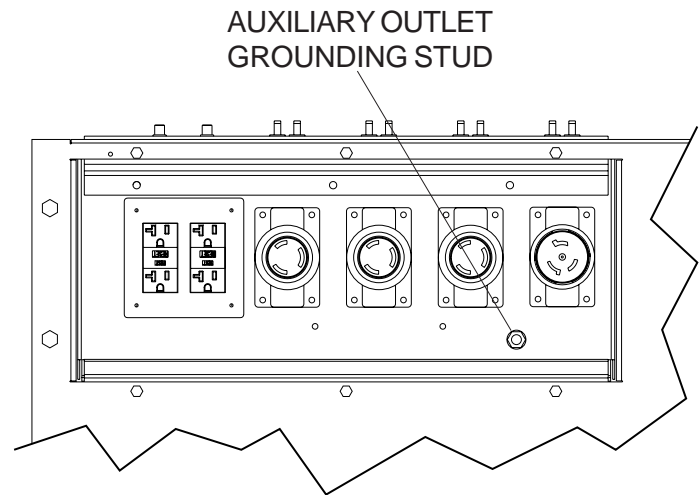

VOLTAGE REGULATION

System stability is the ability of the generator to respond to load transients. Decreasing stability makes the generator less sluggish and faster to respond to load transients. If the stability of the regulator is decreased too much, the generator will tend to hunt under steady state conditions. To adjust the regulation, see the included manual for the voltage regulator. The regulator is located behind the control panel on the back of the generator box.

FINE VOLTAGE ADJUSTMENT

The output voltage can be fine adjusted after the generator is running by using the fine voltage adjustment knob. The switch is located directly below the control power switch next to the control panel. This rheostat will provide an increase (“+”) or a decrease (“-”) in the output voltage. To adjust the voltage, check the output voltage on the LCD display. Turn the knob in the desired direction until the required voltage is shown on the LCD display.

EMERGENCY STOP SWITCH

The generator is equipped with one emergency stop switch, located on the side panel next to the auxiliary outlet panel. The switch is clearly labeled with “**EMERGENCY STOP**” and is red in color. The switch can be accessed and activated with all doors closed and locked.

Activate the emergency stop switch by pushing the red button in until it locks down. This will trip the main circuit breaker which will open the contact disconnecting the load to the connection lugs. This will also open the fuel pump solenoid, shutting down the engine and the Emergency Stop fault will be displayed on the LCD. The switch will remain closed until it is pulled out.

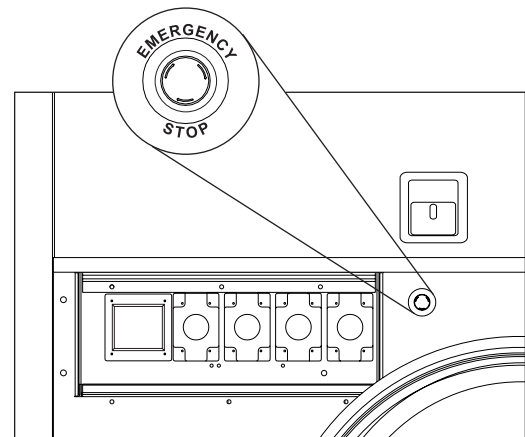

CAUTION! Use the **EMERGENCY STOP** only when the generator must be shut down immediately. For any other shut down, follow the detailed shut down procedure.

MAIN CIRCUIT BREAKER

The main circuit breaker is located on the main control panel. When the breaker is in the off “O” position, power is interrupted between the customer connection lugs and the generator. Once the connections have been made to the connection lugs and the generator has been started and allowed to reach normal operating temperature, the breaker may be switched to the on “I” position.

The main circuit breaker will be tripped, disconnecting power to the connection lugs, if any of the following items occur while the unit is running:

1. Overload of the generator circuits to the connection lugs.
2. The door covering the customer connection lugs is opened.
3. If the emergency stop switch is activated.

Make sure that any problems that caused the main circuit breaker to trip are corrected before returning the switch to the on “I” position.

WARNING!

THE MAIN CIRCUIT BREAKER INTERRUPTS POWER TO THE CUSTOMER CONNECTION LUGS ONLY. THE CUSTOMER CONVENIENCE OUTLETS HAVE POWER EVEN IF THE MAIN CIRCUIT BREAKER IS IN THE OFF “O” POSITION. The auxiliary outlet main circuit breaker, located next to the main circuit breaker, will disconnect all power to the auxiliary outlet panel.

REMOTE START TERMINAL BLOCK

The remote start terminal block is located under the lug box door just below the voltage selector switch. It provides a connection for installation of a remote start switch which will allow the generator to be started by a remote dry-contact closure switch.

Before pressing the “AUTO” button, verify that the contacts on any remote switch linked to the generator are OPEN. If the contacts on a remote switch are closed, the generator will crank and start when AUTO is selected on the controller. Attach the switch leads to the two unused terminals on the generators remote start block. For additional information on starting the generator, see GENERATOR START UP section of this manual.

When the generator is used as a standby power supply, it must be equipped with a transfer switch which isolates it from the utility’s distribution system. A transfer switch is designed to transfer electrical loads from the normal power source (utility) to the emergency power source (generator) when normal voltage falls below a prescribed level. The transfer switch automatically returns the load back to the normal source when power is restored back to operating levels.

WARNING!

Failure to isolate the generator from the normal power utility can cause potentially lethal voltage to backfeed into the utility lines. This may result in injury or electrocution of utility workers nearby. Make sure that the generator is isolated by a transfer switch from any local utility lines. This also applies if the generator is being used as a back up to some other type of power supply.

Installation of a transfer switch or other type of remote starting device is the responsibility of the generator user. Installation of such devices must be performed by following all directions supplied by the manufacturer of the switch. If attaching generator to a power supply normally serviced by a utility company, notify the utility company and check local and state regulations. Familiarize yourself with all instructions and warning labels supplied with the switch.

WARNING!

It is strongly recommended that ONLY a licensed electrician perform any wiring and any related connections to the generator. Installation should be in compliance of the National Electric Code as well as any state or local codes or regulations. Failure to follow these procedures could result in property damage, personal injury or death. Before any connections are attempted, make sure the main circuit breaker and the engine start switch are in the OFF "O" position.

WARNING!

When using the generator as a stand by or substitute power supply, make sure the output voltage and phase rotation of the generator match those of the local power utility. Improper voltage or phase rotation may cause equipment damage or malfunction.

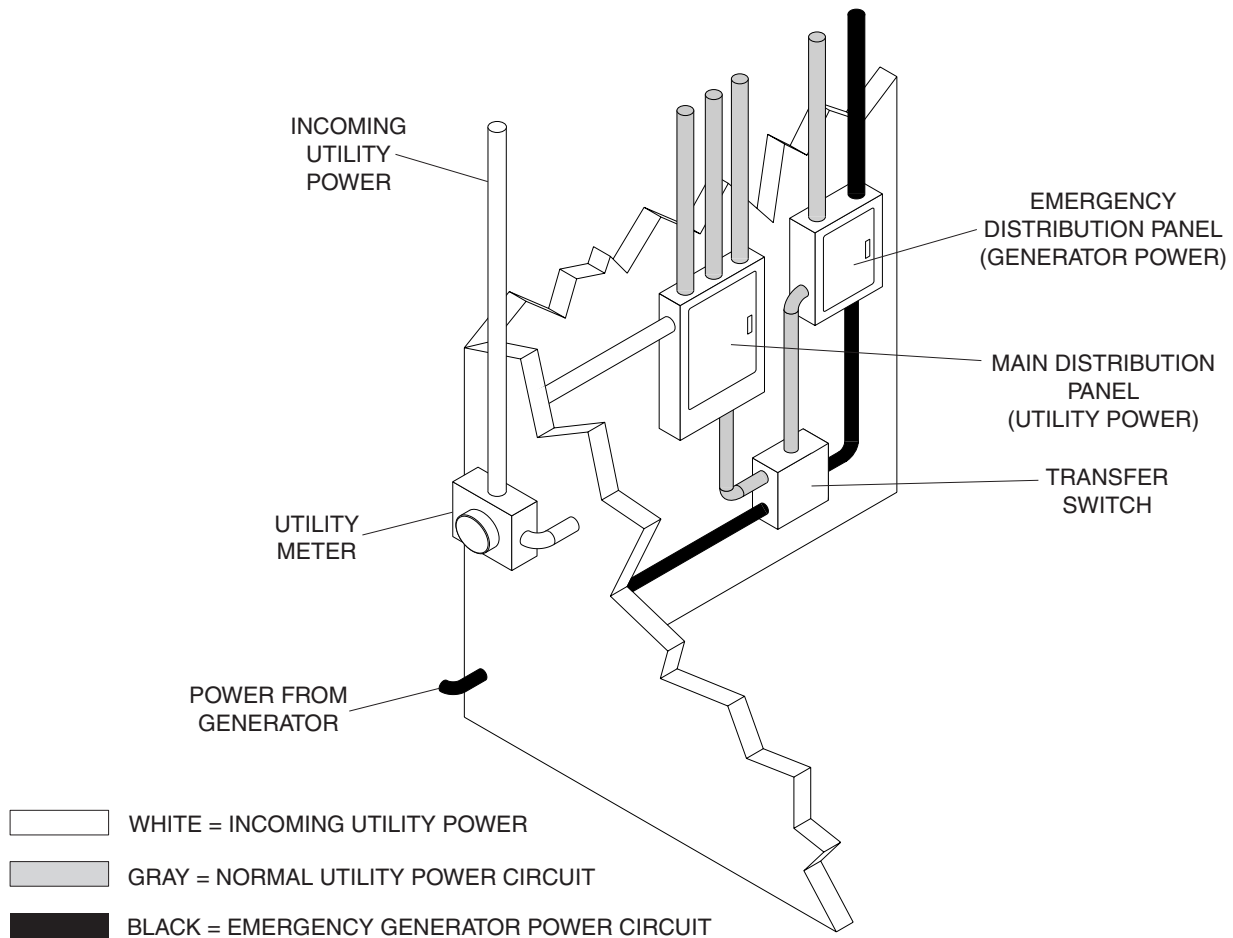

GENERATOR START UP

Before starting the generator, carefully read the pre-start check list. Make sure that all of the items are checked before trying to start the generator. This check list applies for both manual and remote starting of the generator.

PRE-START CHECK LIST

1. Make sure the **control power switch is in the OFF “O” position.**
2. Make sure that the **circuit breakers (main and convenience) are switched OFF “O”.**
3. Check that the **generator is properly grounded** to a good earthen ground per local and NEC regulations.
4. Check all **electrical connections at the connection lugs.** Are they wired correctly?
5. Are the connection lugs tight?
6. Check the **voltage selector switch and make sure that it is set to the desired voltage.**
7. Is the voltage selector switch locked?
8. Is the generator sitting level?
9. Check for any water inside the unit, on or near the generator. Dry the unit before starting.
10. Check engine oil level, engine coolant level and engine battery connections.
11. Check engine fan belt tension and condition.
12. Check engine fan belt guard.
13. Check engine exhaust system for loose or rusted components.
14. Check radiator and surrounding shroud for debris.
15. Are any of the generator covers loose or missing?

MANUAL STARTING OF THE GENERATOR

1. Move the control power switch to the “CONTROL ON” position.
2. The LCD screen will quickly display system information, all LEDS will flash.

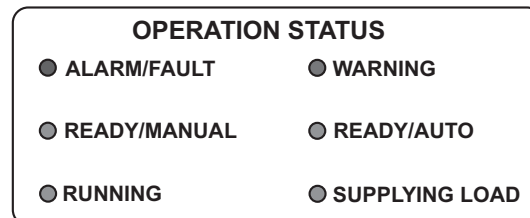
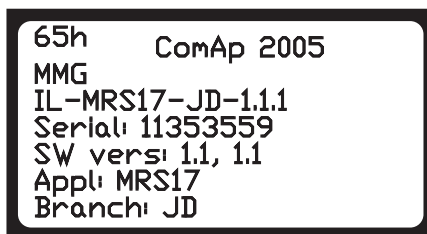

3. The LCD Screen will indicate MANUAL mode and Ready. Ready/Manual LED will be lit.

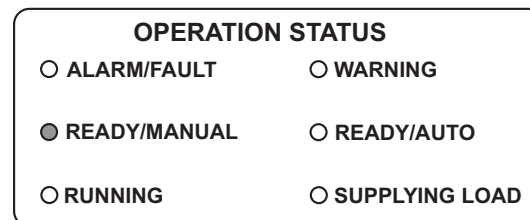
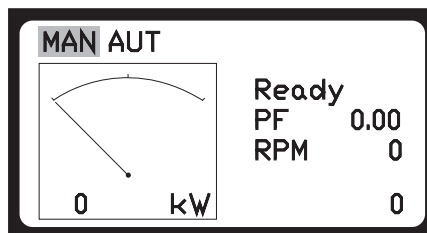

4. Press the green ENGINE START key.
NOTE: Unit must be in MAN Mode with READY/MANUAL LED lit.

5. The Prestart screen will display (if equipped).

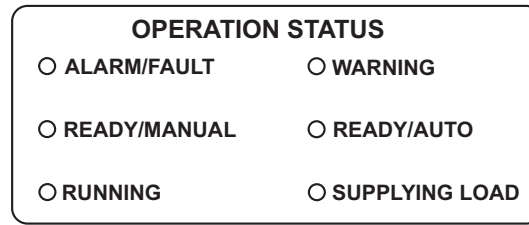
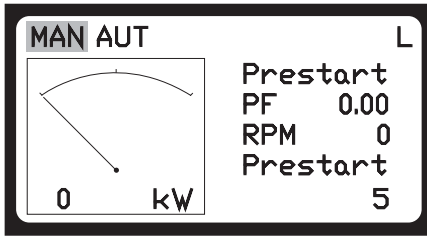

6. The Starting screen will display. The engine will crank and start running.

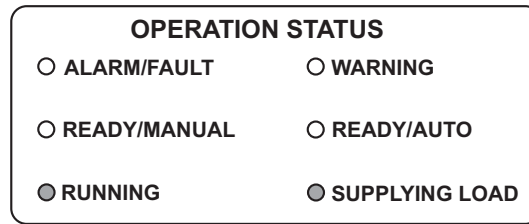
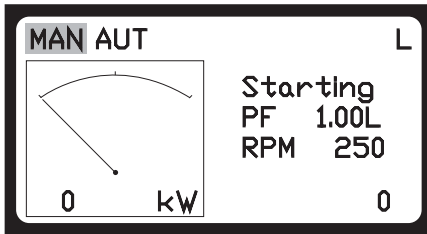

7. The Running screen will display.

NOTE: It may take a few seconds for the engine to run smoothly and reach its governed operating speed.

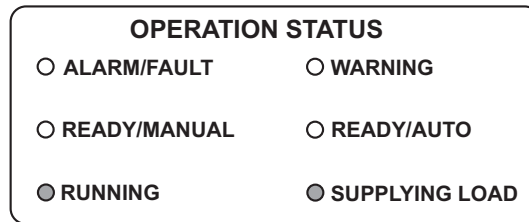
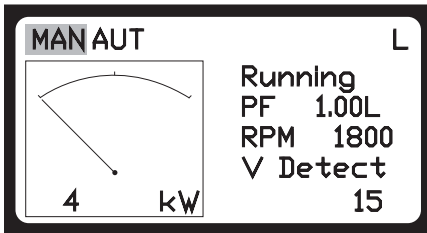

8. The LCD will switch from the POWER SCREEN DISPLAY to:

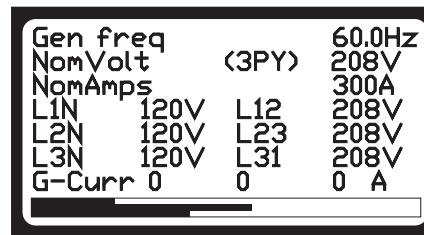
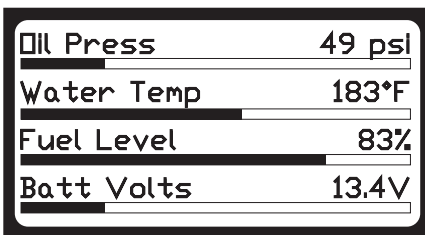

9. If the engine does not start after the first cranking attempt the engine will wait for 15 seconds to allow the starter to cool and the LCD will show "Pause". The engine will make two more attempts to start for a total of three crank cycles.

10. Should the engine not start and run the LCD display will show "SD StartFail". The starting sequence may be repeated after the starter has had a minimum of two minutes to cool. The FAULT RESET button needs to be pressed to clear the controller. The unit will start by pressing the ENGINE START button.

Note: the engine controller may skip the pre-heat acquisition and engine pre-heat steps.

11. Once the engine starts it will slowly begin speeding up to a constant 1800 rpm. On units with isochronous engine governing, the engine may hunt or change speeds until operating temperature is reached. After a few minutes of operation the engine will be warmed up and the LCD display will show engine and generator operating parameters. Temperature will be shown as "0" until the engine temperature is approximately 100 degrees Fahrenheit.

Once the generator is at normal operating temperature, check the generator for excessive noise, vibration and coolant, oil or fuel leaks before applying any loads.

12. Check that the AC output voltage is correct. The output voltage can be fine adjusted by using the fine voltage adjustment switch, described on page 16.
13. Check that the frequency (Hz) is correct. With no loads connected to the generator, the frequency should read approximately 60-62 Hz, depending on the type of engine governing used.
14. If all wiring connections have been done correctly, switch the main circuit breaker to the on "I" position and then add any loads attached to the convenience outlets by switching the respective circuit breaker to the ON "I" position. You will notice a slight change in engine noise.

AUTO (REMOTE) STARTING OF THE GENERATOR

The AUTO button is used when the generator is started from a location other than the control panel by using a remote start switch or transfer switch. AUTO (remote start) is the normal setting when the generator is being used as a standby power supply. Before putting the generator in the AUTO (remote start) mode, review the PRE-START CHECK LIST and MANUAL STARTING OF THE GENERATOR sections beginning on page 18. Also follow all safety warnings and information on isolating the generator with a transfer switch if the unit is to be used as a standby power supply on pages 16 and 17. Then continue with the steps described below:

1. Perform a manual start of the generator at least once to verify that the engine is operating correctly.
2. If a check of the remote start circuit is desired, press the "AUTO" button. The LCD display should highlight "AUT" in the upper left corner. Attach a jumper wire (minimum 16 gauge) equipped with two alligator clips across the two unused terminals on the remote start terminal block. This applies a ground to the EZ-1 to close the starting circuit. The engine should crank, start and run.
3. Remove the jumper wire from the remote start terminal block, the engine will stop. Connect any necessary wires from the remote start switch.
4. Confirm unit is in "AUTO" mode. The LCD display should have "AUT" highlighted in the upper left corner.
5. Close (set to ON/"I") the main circuit breaker.
6. Secure the generator by closing and locking all access doors.
7. The generator is now ready for remote starting.

SHUTTING DOWN THE GENERATOR

Check with other personnel using power supplied by the generator and let them know that the power is going to be turned off. Make sure the power shutdown will not create any hazards by accidentally turning off equipment that needs to be kept on (pumps, compressors, lights, etc.).

1. Remove all loads from the generator by opening (turn to OFF/"O") all circuit breakers.
2. Let the engine run for approximately five minutes to allow it to cool down.
3. Push the "ENGINE STOP" button.
4. Move the control power switch to the CONTROL OFF/"O" position.

EZ-1 CONTROLLER INFORMATION DISPLAYS AND FUNCTION

The MAGNUM EZ-1 controller constantly monitors vital generator and engine functions for a number of operation, alarm and fault conditions. When a fault condition occurs, the engine will shut down automatically and the LCD display will show the fault that has caused the shut down. To resume operation, the fault condition must be resolved. To reset the EZ-1 and resume operation, press the "FAULT RESET" button. Operation, alarm and fault conditions and (displayed message) are described in the following table:

CONTROLLER ALARM LIST WITH DESCRIPTION

Alarm Display	Shutdown or Alarm	Description	Possible Cause
Wrn Oil press	Alarm	Warning level of oil pressure reached	Low oil, faulty sender, low engine oil pressure
Sd Oil press	Shut Down	Shutdown Level of oil pressure reached	Low oil, faulty sender, failed engine
FIs Oil Pressure	Alarm	False Oil Pressure Sender Signal	Sending unit / wiring defective
Wrn Wtemp Low	Alarm	Warning water temp is cold	Cold exterior, block heater not functioning
Wrn Water temp	Alarm	Warning for High water temp	Low water level, thermostat, faulty sending unit, poor radiator performance
Sd Water temp	Shut Down	Shutdown level for high water temp	Low water level, thermostat, faulty sending unit, poor radiator performance
FIs Water Temp	Alarm	False Water Temp Sender Signal	Sending unit / wiring defective, water temp outside of sender curve
Wrn Fuel Level	Alarm	Warning level for Low Fuel	Low fuel / faulty sender
Sd Fuel Level	Shut Down	Shutdown for Low Fuel Level	Low fuel, faulty sender
FLS Fuel Level	Alarm	False Fuel Level Signal	Sending unit / wiring defective
Emergency Stop	Shut Down	E stop mechanism has been activated	Emergency Stop has been activated
Wrn Overload	Alarm	Warning level of kW overload reached	Approaching kW overload shutdown
Sd Overload	Shut Down	Shut down level of kW overload reached	kW draw on generator is to high
Sd Underspeed	Shut Down	Shutdown level for underspeed Reached	Fuel, air, generator load
Stop Fail	Shut Down	Controller expects unit to be shutdown, but is receiving engine running data	Fuel rack stuck
Sd Overspeed	Shut Down	Shutdown level for Overspeed reached	Slow reaction to rapid unload, Engine governor, incorrect flywheel setting
Wrn Batt Volt	Alarm	Warning level for high or low battery voltage	Replace alternator, DC voltage regulator, battery
Wrn Vg1 Under	Alarm	Warning level for Line 1 under voltage	No generator output, Voltage regulator, safety switch
Wrn Vg2 Under	Alarm	Warning level for Line 2 under voltage	No generator output, Voltage regulator, safety switch
Wrn Vg3 Under	Alarm	Warning level for Line 3 under voltage	No generator output, Voltage regulator, safety switch
Sd Vg1 Under	Shut down	Shutdown level for Line 1 under voltage	No generator output, Voltage regulator, safety switch
Sd Vg2 Under	Shut Down	Shutdown level for Line 1 under voltage	No generator output, Voltage regulator, Safety switch
Sd Vg3 Under	Shut Down	Shutdown level for Line 1 under voltage	No generator output, Voltage regulator, safety switch
Wrn Vg1 Over	Alarm	Warning level for Line 1 over voltage	Voltage regulator, voltage adjustment after V-detect time delay
Wrn Vg2 Over	Alarm	Warning level for Line 2 over voltage	Voltage regulator, voltage adjustment after V-detect time delay
Wrn Vg3 Over	Alarm	Warning level for Line 3 over voltage	Voltage regulator, voltage adjustment after V-detect time delay
Sd Vg1 Over	Shut Down	Shutdown level for line 1 over voltage	Voltage regulator, voltage adjustment after V-detect time delay
Sd Vg2 Over	Shut Down	Shutdown level for line 2 over voltage	Voltage regulator, voltage adjustment after V-detect time delay
Sd Vg3 Over	Shut Down	Shutdown level for line 3 over voltage	Voltage regulator, voltage adjustment after V-detect time delay
Sd Igen Unbal	Shut Down	Shutdown level for Generator current unbalance condition	Generator load is unbalanced, failed equipment
Sd Vgen Unbal	Shut Down	Shutdown level for generator voltage unbalanced	Generator load is unbalanced, failed equipment
Wrn Fgen Under	Alarm	Warning for generator under frequency	Fuel, air, generator load
Sd Fgen Under	Shut Down	Shutdown for generator under frequency	Fuel, air, generator load
Wrn Fgen Over	Alarm	Warning level for Generator over frequency	Slow reaction to rapid unload, Engine governor, incorrect flywheel setting
Sd Fgen Over	Shut Down	Shut down level for Generator over frequency	Slow reaction to rapid unload, Engine governor, incorrect flywheel setting
Sd IDMT	Shut Down	Shut down for delayed overcurrent	Generator current is higher than setpoint, reduce load
Sd Short Igen	Shut Down	Shut down for instantaneous current overload	Generator is overloaded, possible motor starting issue, reduce load
Wrn Service Time	Alarm	Time to service has expired	Engine needs service, reset time to service interval clock

CONTROLLER ALARM LIST WITH DESCRIPTION (CONTINUED)

Alarm Display	Shutdown or Alarm	Description	Possible Cause
Sd StartFail	Shut Down	Engine failed to start after 3 attempts	Fuel, air, engine, battery issue
Wm ECU Comm	Alarm	J1939 Communication failure to the engine ECU	Com bus wiring issue, Engine ECU issue, Battery disconnect switch off, blown fuse on John Deere harness
G ph opposed	Alarm	Wrong Generator phase sequence (L1, L2, L3)	Generator phases L1, L2, L3, COM are not terminated in proper location on controller
Gen L1 neg	Alarm	Generator phase L1 is inverted	
Gen L2 neg	Alarm	Generator phase L2 is inverted	
Gen L3 neg	Alarm	Generator phase L3 is inverted	
Gph + L1 Neg	Alarm	Wrong generator sequence (L1, L2, L3) and is inverted	
Gph + L2 Neg	Alarm	Wrong generator sequence (L1, L2, L3) and is inverted	
Gph + L3 Neg	Alarm	Wrong generator sequence (L1, L2, L3) and is inverted	
ECU Com Fail		Controller failed to communicate with engine computer	
ECU alarm	Alarm/SD	See ECU alarm list John Deere Book for correct series engine	

TROUBLESHOOTING AUTOMATIC SHUTDOWN CONDITIONS

LOW OIL PRESSURE SHUTDOWN

1. Check the level of the engine oil with the dipstick. The EZ-1 will shut the engine down when the oil pressure is less than 20 psi. Add oil if required.
2. Visually inspect the engine for oil leaks.
3. If the oil level is good, restart the unit and verify the loss of oil pressure. Shut the engine down immediately if the oil pressure value does not read 5 PSI within five (5) seconds.
4. Check the oil pressure sender on the engine block and the connecting wiring for damage. To check for continuity between the sender and the EZ-1, remove the bolts at the top and center of the control panel and open the panel like a door. Consult the DC wiring diagrams in this manual for the proper path between the EZ-1 and the pressure sender.
5. If the oil level, pressure sender and wiring are good, the oil loss may be caused by engine failure. Consult the engine OPERATION AND MAINTENANCE MANUAL for additional information on excessive oil consumption.

HIGH COOLANT TEMPERATURE SHUTDOWN

1. Check the coolant level in the overflow jug.
2. Restart the engine and read the coolant temperature to verify High Coolant Temperature Shutdown. Stop the engine immediately if the coolant temperature is 230°F or more.
3. **Allow the engine to cool!** Add coolant to the overflow jug if it is low and then check the level of coolant in the radiator. To access the radiator cap, you must remove a small panel on top of the generator housing directly above the radiator. Add coolant until it is 3/4" below the filler neck. Replace the radiator cap and access panel.
4. Check the radiator shroud and ducting for blockage and remove any foreign matter.
5. Inspect coolant hoses, engine block and water pump for visible leaks.
6. Check the tension of the serpentine drive belt for the water pump.
7. Check the coolant temperature sender on the engine block and the connecting wiring for damage. To check for continuity between the sender and the EZ-1, remove the bolts around the control panel and slowly drop panel down. Consult the DC wiring diagrams in this manual for the proper path between the EZ-1 and the pressure sender.
8. If the sender and wiring are good and no other problems are found, restart the engine. Observe the coolant temperature and shut the engine down immediately if it starts to overheat.
9. Reduce the load on the generator and restart the engine. Observe the coolant temperature and shut the engine down immediately if it starts to overheat. Consult the engine OPERATION AND MAINTENANCE MANUAL for additional information on engine overheating.

TROUBLESHOOTING AUTOMATIC SHUTDOWN CONDITIONS, CONTINUED

OVERCRANK SHUTDOWN

1. Check the fuel level in tank.
2. Check for proper operation of the fuel pump.
3. If the engine will not start, consult the engine OPERATION AND MAINTENANCE MANUAL for additional information on troubleshooting starting problems.

OVERSPEED OR UNDERSPEED SHUTDOWN

1. Disconnect all loads and restart the generator. Read the frequency (Hz) on the LCD display. With no loads on the generator, the frequency should read 60.0 Hz.
2. If the frequency is above or below 60.0 Hz, the engine speed will have to be adjusted. See the engine manual for throttle adjustments on mechanical governed units and see the electronic governor manual for electronically controlled units.

TOWING THE TRAILER

1. Use the jack to raise or lower the trailer onto the hitch of the towing vehicle. Lock the hitch coupling and attach the safety chains or cables to the vehicle. Release the jack locking pin and rotate the jack into the travel position. Make sure the locking pin snaps into place.
2. Connect any trailer wiring to the tow vehicle. Check for proper operation of the stop and signal lights.
3. Make sure the doors are properly latched.
4. Check for proper inflation of the trailer tires.
5. Check the wheel lugs. Tighten or replace any that are loose or missing. If a tire has been removed for axle service or replaced, tighten the lugs in the order shown to the following specifications:
 - A. Start all lug nuts by hand.
 - B. First pass tighten to 20-25 Ft-Lbs (27-33 Nm).
 - C. Second pass tighten to 50-60 Ft-Lbs (67-81 Nm).
 - D. Third pass tighten to 90-120 Ft-Lbs (122-162 Nm).

After the first road use, retorque the lug nuts in sequence.

6. Maximum recommended speed for highway towing is 45 m.p.h.. Recommended off-road towing speed is not to exceed 10 m.p.h. or less depending on terrain.

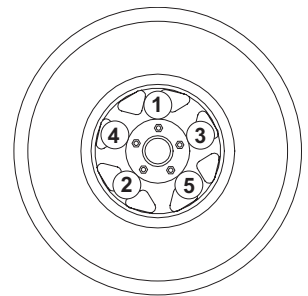

TRAILER WHEEL BEARINGS

The generator is equipped with a grease zerk fitting to allow lubrication of the wheel bearings without the need to disassemble the axle hub. To lubricate the axle bearings, remove the small rubber plug on the grease cap, attach a standard grease gun fitting to the grease zerk fitting and pump grease into the fitting until new grease is visible around the nozzle of the grease gun. Use only a high quality grease made specifically for lubrication of wheel bearings. Wipe any excess grease from the hub with a clean cloth and replace the rubber plug when finished. The minimum recommended lubrication is every 12 months or 12,000 miles; more frequent lubrication may be required under extremely dusty or damp operating conditions.

ENGINE AND GENERATOR MAINTENANCE

Poorly maintained equipment can become a safety hazard! In order for the equipment to operate safely and properly over a long period of time, periodic maintenance and occasional repairs are necessary. NEVER perform even routine service (oil/filter changes, cleaning, etc.) unless all electrical components are shut down. When servicing this equipment always follow the instructions listed below.

Before servicing this machine, make sure the control power switch is turned to off “O”, the circuit breakers are open (off, “O”), the emergency stop switch is activated (pushed in), and the negative (-) terminal on battery is disconnected. Attach a “DO NOT START” sign to the control panel. This will notify everyone that the unit is being serviced and will reduce the chance of someone inadvertently trying to start the unit. If the unit is connected to a remote start or transfer switch, make sure the remote switch is also off and tagged.

Never wash the unit with a high pressure hose or with any kind of power washer. Never wash the engine block or fuel tank with a power washer or steam cleaner. Water may enter the cabinet and collect in the generator windings or other electrical parts, causing damage. If the unit is stored outside, check for water inside the cabinet and generator and dry the unit thoroughly before starting.

RELOADING THE TIME TO SERVICE REMINDER

After scheduled service work has been completed, it is necessary to reload the Time To Service reminder on the controller. The timer can be reset to count down from 250 hrs. Follow the programming instructions below:

1. Press PAGE SELECT
2. Press ▼ to select > **Engine protect**
3. Press ENTER
Display reads > **NextServTime**
4. Press ENTER
5. Press ▲ to scroll value to **250**
6. Press **ENTER**
7. Press **PAGE SELECT**, Press **PAGE SELECT** again to exit

ADJUSTING DISPLAY BACK LIGHTING

While in any screen except programming:

Press and hold **ENTER** while pressing ▼ to decrease contrast.

Press and hold **ENTER** while pressing ▲ to increase contrast.

DAILY MAINTENANCE CHECKS

Check the engine oil level daily before starting engine. DO NOT start the generator if the oil level is below the ADD mark on the dipstick. The normal operating level for the engine oil is anywhere in the crosshatch pattern between the FULL and ADD markings. Add oil to the engine only if the level is below the ADD mark on the bottom of the crosshatch pattern. DO NOT OVERFILL the crankcase. Consult the engine OPERATION AND MAINTENANCE MANUAL for the proper grade of oil, including special operating conditions such as a change in season or climate.

Check the coolant level daily. The coolant is checked by visually inspecting the level in the coolant overflow jug, located near the radiator. The normal operating level is anywhere between the FULL and ADD markings on the overflow jug, with the optimum level noted as "NORMAL RANGE". Coolant may be added directly to the overflow jug WHEN THE ENGINE IS STOPPED AND COMPLETELY COOL. Consult the engine OPERATION AND MAINTENANCE MANUAL for coolant recommendations and proper mixture.

Check the condition of the air filter viewing the level of vacuum draw on the filter minder gauge. Replace the air filter when the yellow center bar reaches the red section on the gauge (20 in. H₂O).

Use the schedule in the table below as a guide for regular maintenance intervals.

ITEM	DAILY	50 HRS.	250 HRS.	500 HRS.	1000 HRS.
Check engine oil level	■				
Check air cleaner and filter minder gauge *	■				
Check engine coolant level	■				
Visual walk around inspection	■				
Check fuel filter		■			
Check all electrical connections and outlets			■		
Service the battery			■		
Change engine oil and replace filter **			■		
Check air intake hoses, connections, and system				■	
Replace fuel filter element				■	
Check automatic belt tensioner and/or belt wear				■	
Check cooling system				■	
Perform coolant solution analysis				■	
Adjust engine droop					■
Pressure test cooling system					■
Flush cooling system ***					■
Check and adjust engine valve clearance					■

* If equipped, replace primary air cleaner when restriction indicator shows a vacuum of 25 in. H₂O.

** Change the oil and oil filter after the first 100 hours, then every 250 hours.

*** If engine manufacturer's recommended coolant is used, the flushing interval may be extended. See engine OPERATION AND MAINTENANCE MANUAL.

DERATING FOR ALTITUDE

All generator sets are subject to derating for altitude and temperature; this will reduce the available power for operating to tools and accessories connected to the auxilliary outlets. Typical reductions in performance are 2-4% for every 1000 ft. (305 meters) of elevation and 1% per 10° F (3-5° C) increase in ambient air temperature over 72° F (22.2° C).

FRAME ASSEMBLY

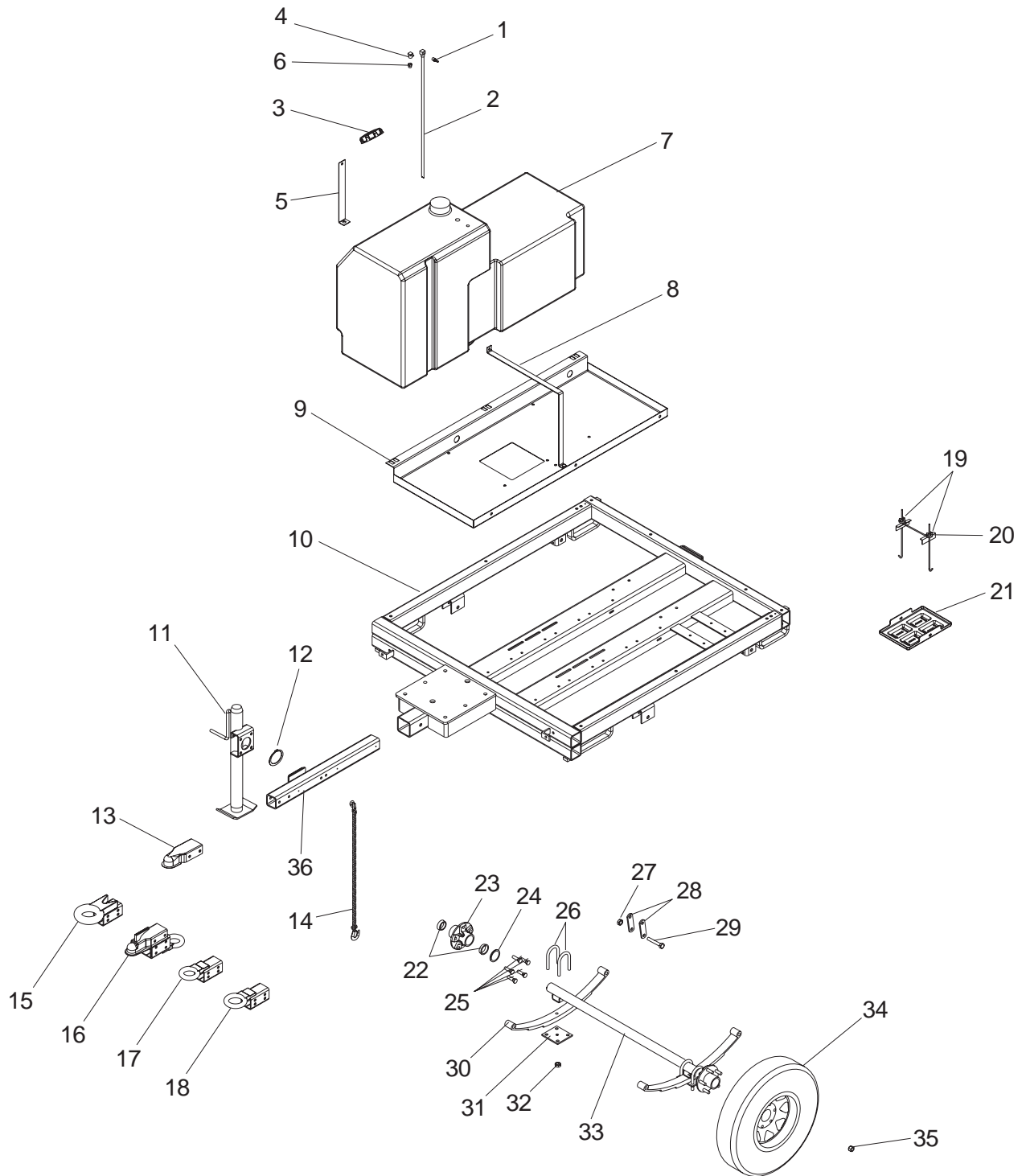

FRAME ASSEMBLY

ITEM NO.	PART NO.	QTY	DESCRIPTION
1	15142	1	Fitting, .250NPT x .312 hose barb
2	12259	1	Fuel pick-up tube, 24.00 in.
3	12080	1	Cap, fuel tank vented - 3.5 in. green
4	16271	1	Fitting, .250NPT x .188 hose barb
5	12361B	1	Weldment, fuel tank strap (small)
6	16270	1	Fitting, .375MNPT x .250FNPT
7	12162	1	Tank, fuel - 56 gallon poly
8	12359B	1	Weldment, fuel tank strap (LRG)
9	12358B	1	Pan, fuel tank flat frame
10	11563B	1	Weldment, lt/gen chassis
11	14223	1	Jack, sidewind - 2000 lb.
12	14326	1	Ring, retaining
13	16830	1	Coupler, 2 in. ball/2.5 in. channel
14	14521	2	Chain, safety - 44in, w/hook
15	11672B	1	Weldment, hitch - 3.00x1.625 ring/2.50 tube
16	16741B	1	Weldment, combo hitch - 2.5" tongue
17	16835B	1	Weldment, lunette ring - 3.00 ID/2.5 tongue
18	16999B	1	Weldment, lunette ring - 2.50 ID/2.5 tongue
19	14146	2	Bolt, J - .250-20 x 10 (battery)
20	14682	1	Bracket, battery hold down
21	14145	1	Battery tray
22	11511	4	Axis axle roller bearing
23	11276	2	Axis, axle hub (new) w/races 3500lb.
24	11199	2	Axle bearing seal
25	60674	10	Stud, wheel
26	11277	4	Axle U-bolt 3500 lb.
27	60504	6	Nut, .562-18 hx shackle lock
28	19637	4	Plate, shackle bracket
29	60503	6	Screw, .562-18 hx shackle
30	11280	2	Axis leaf spring, 3500 lb.
31	11278	2	Axle tie plate, 3500 lb.
32	11279	8	Axle nut (u-bolt) 3500 lb.
33	11385	1	Axle, 2200 lb.
34	15540	2	Wheel, 15" with rim
35	60096	10	Nut, .500-20 wheel lug
36	15828B	1	Weldment, removable tongue
--	960151	--	Spare tire group - 15" (optional, not shown)

ENCLOSURE ASSEMBLY

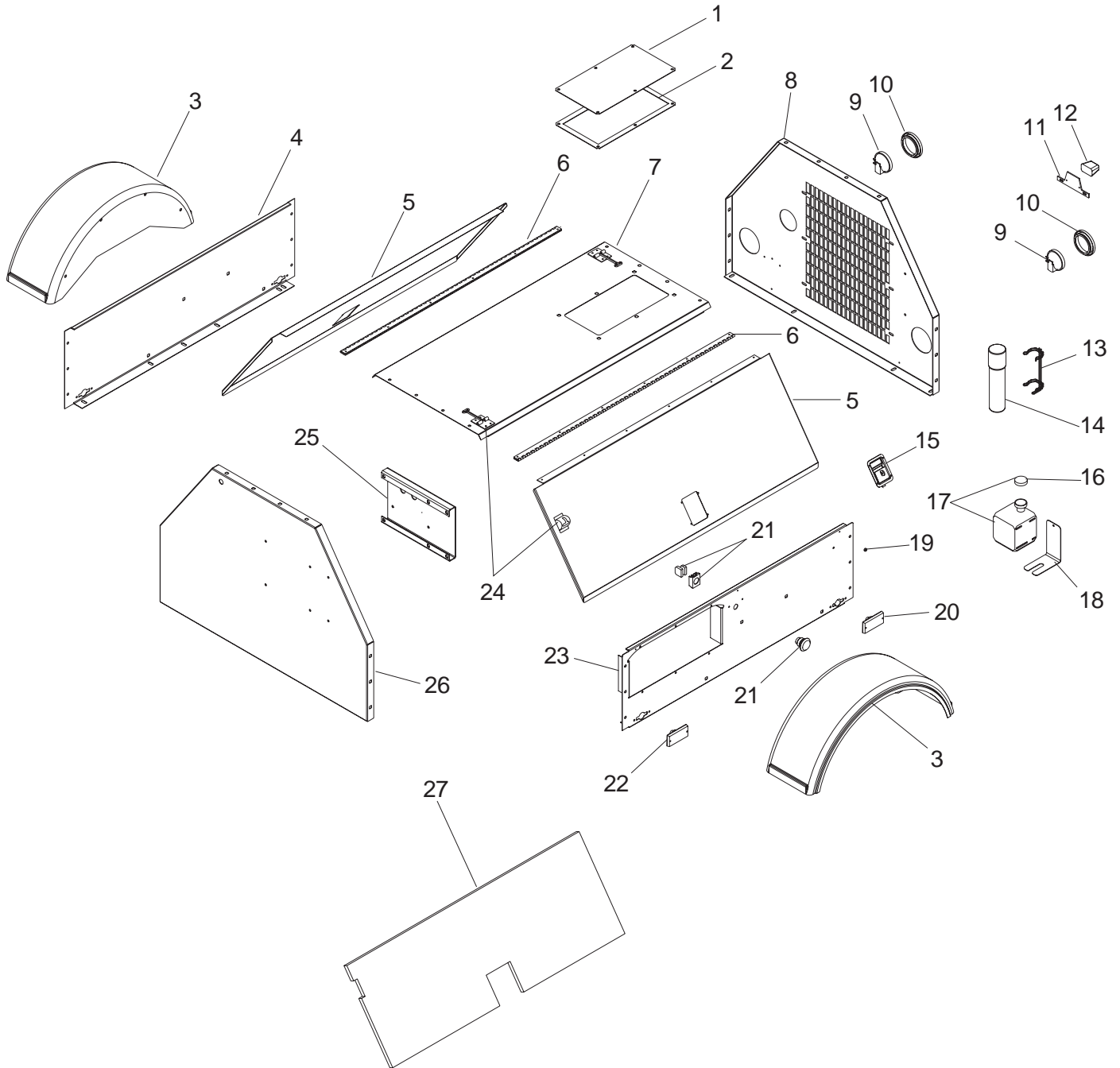

ENCLOSURE ASSEMBLY

ITEM NO.	PART NO.	QTY	DESCRIPTION
1	25333W	1	Panel, back access
2	12195	1	Gasket, radiator access plate
3	11381	2	Fender, plastic
4	11507W	1	Panel, right side sheetmetal
5	16591W	2	Panel, door
6	16598	2	Hinge, door
7	10284W	1	Panel, roof w/access hole
8	10287W	1	Panel, rear 4000 isuzu
9	10220	2	Light, rear tail/turn mlr no grommet
10	10221	2	Grommet, rear light rubber 4.5
	10219	2	Assembly, rear tail/turn light (9 & 10)
11	10224	1	Bracket, license plate
12	10225	1	Light, license bracket
	10223	1	Assembly, license plate light (11 & 12)
13	11222	1	Bracket, manual holder
14	11121	1	Holder, manual black tube
15	15123	2	Latch, paddle
16	19714	1	Cap, over flow jug
17	14410	1	Assembly, overflow jug
18	22419B	1	Bracket, support overflow jug
19	15215	6	Bumper, rubber
20	65406	2	Light, clearance marker red
21	22550	1	Switch, Estop, 2NO/1NC
22	65407	2	Light, clearance marker amber
23	12257W	1	Panel, left side sheetmetal
24	14651	2	Latch, door
25	11886B	1	Bracket, control box
26	12012W	1	Panel, front sheetmetal
27	11724	2	Foam, door
28	12191	1	Decal, label set (not shown)
29	22545	1	Decal, number set (not shown)
30	10222	-	Plug, rear light 3-wire MLT (not shown)
31	10226	-	Plug, 2-wire license light (not shown)

AUXILIARY OUTLET PANEL ASSEMBLY

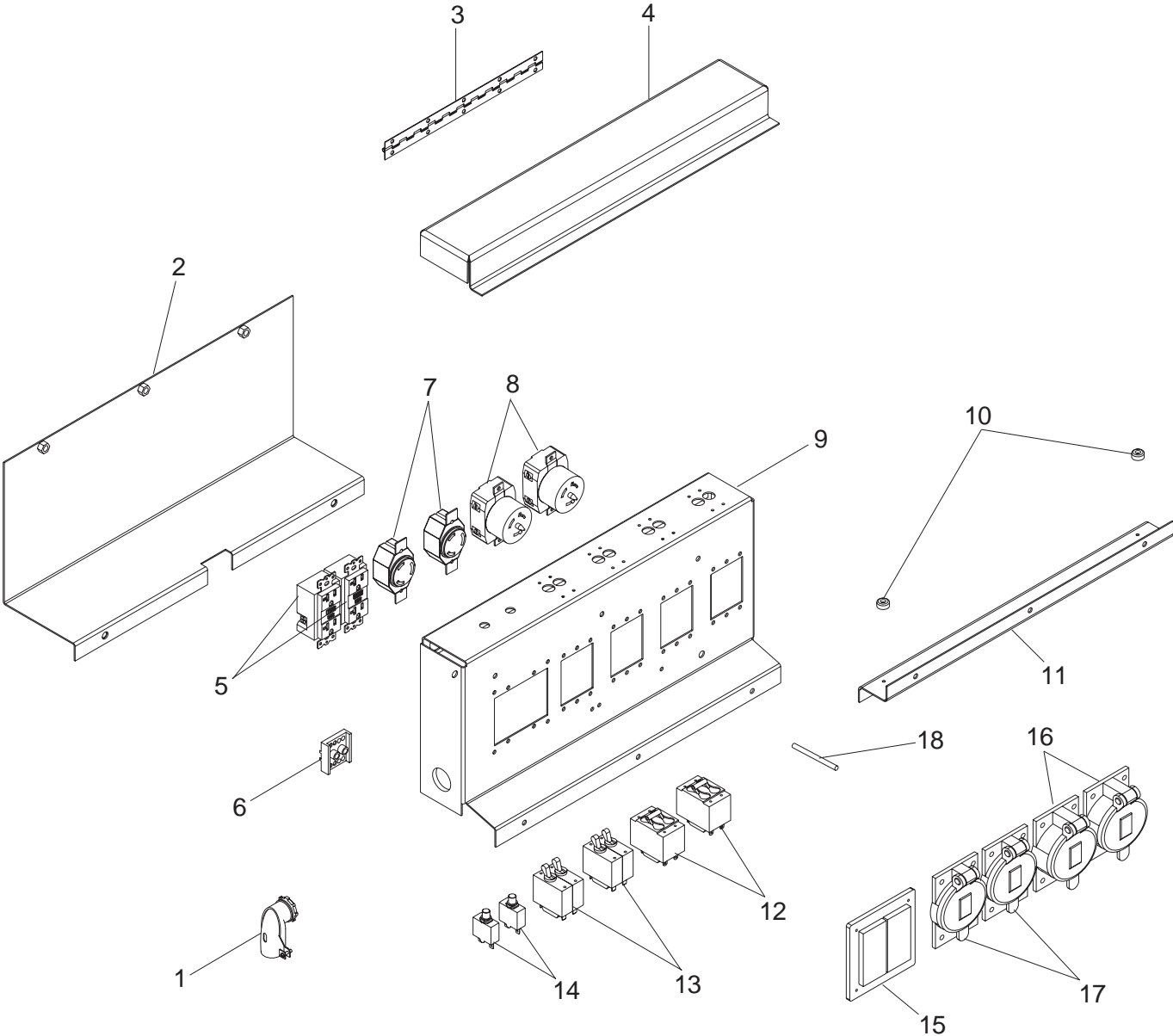

AUXILIARY OUTLET PANEL ASSEMBLY

ITEM NO.	PART NO.	QTY	DESCRIPTION
1	65535	1	Clamp, 90° 3/4" 2 screw
2	12248B	1	Weldment, outlet cover
3	10081	1	Hinge, continuous - 11.00 in.
4	11484B	1	Cover, breaker
5	14130	2	Receptacle, 120V/20A GFCI
6	65530	2	Block, terminal - 2 pole lug type, 7 pos./pole
7	14137	2	Receptacle, 240V/30A twist lock
8	18089	2	Receptacle, 120/ 240V 50A twist lock
9	12246B	1	Weldment, outlet panel
10	15215	2	Rubber bumper
11	11485B	1	Angle, mounting support
12	65492	2	Breaker, 50A, 250V, 2 pole aux contact
13	65387	2	Breaker, 30A, 250V, 2 pole aux contact
14	14156	2	Breaker, 20A, 120V, 1 pole push button
15	15849	1	Cover, receptacle - weather proof
16	65467	2	Cover, receptacle 50A twist lock
17	65460	2	Cover, 20/30A 240V twist lock
18	18992	1	Stud, ground

AUXILIARY OUTLET PANEL OPTIONS

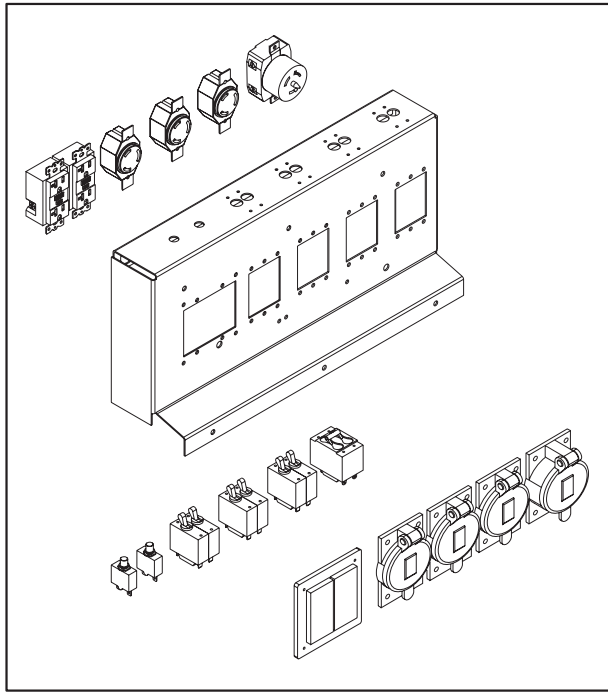

PART NUMBER 12399
 Receptacle Panel (2x5-20R, 3xL6-30R, 1x50A)

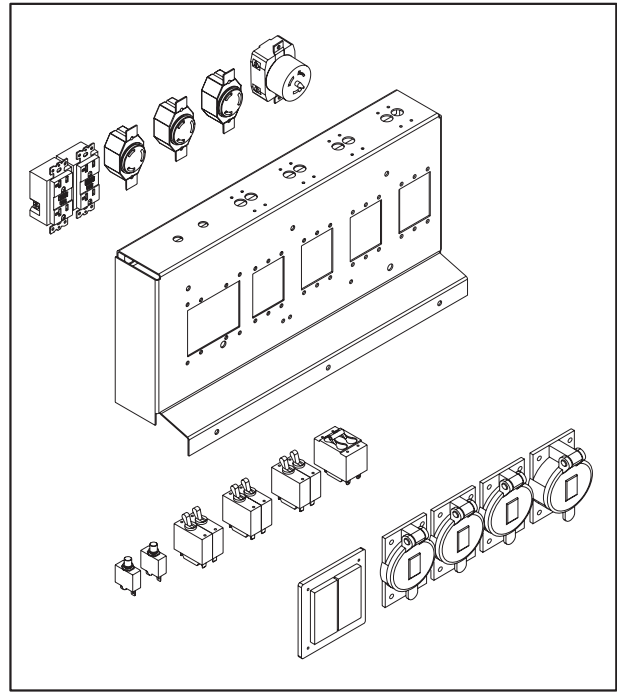

PART NUMBER 12402
 Receptacle Panel (2x5-20R, 3xL6-20R, 1x50A)

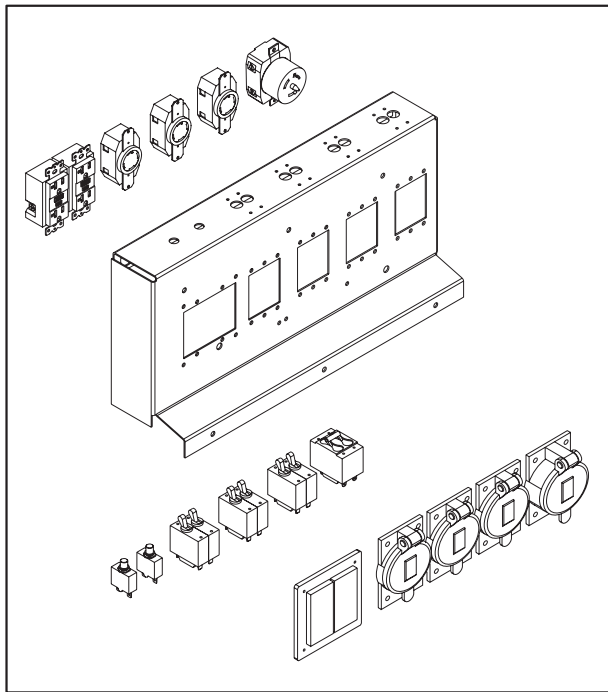

PART NUMBER 12400
 Receptacle Panel (2x5-20R, 3xL14-30R, 1x50A)

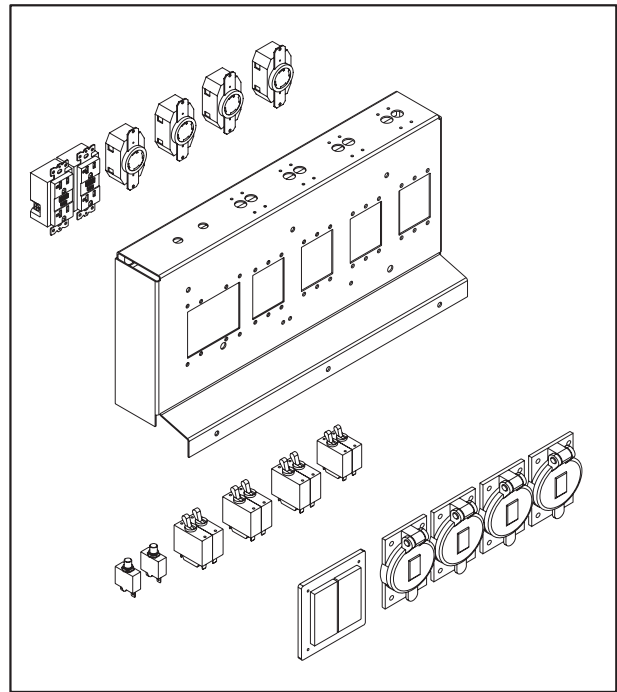

PART NUMBER 12401
 Receptacle Panel (2x5-20R, 4xL14-30R)

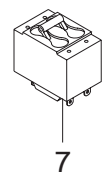
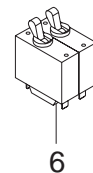
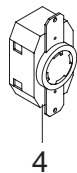
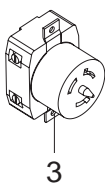
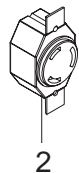
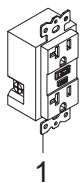

AUXILIARY OUTLET PANEL OPTIONS

ITEM NO.	PART NO.	QTY	DESCRIPTION
1	14130	2	Receptacle, 120V/20A GFCI
2	14137	-	Receptacle, 240V/30A twist lock
3	18089	-	Receptacle, 120/240V 50A twist lock
4	65488	-	Receptacle, 240V/30A twist lock
5	14156	2	Breaker, 20A, 120V, 1 pole push button
6	65387	-	Breaker, 30A, 250V, 2 pole aux contact
7	65492	-	Breaker, 50A, 250V, 2 pole aux contact

ENGINE COOLING ASSEMBLY

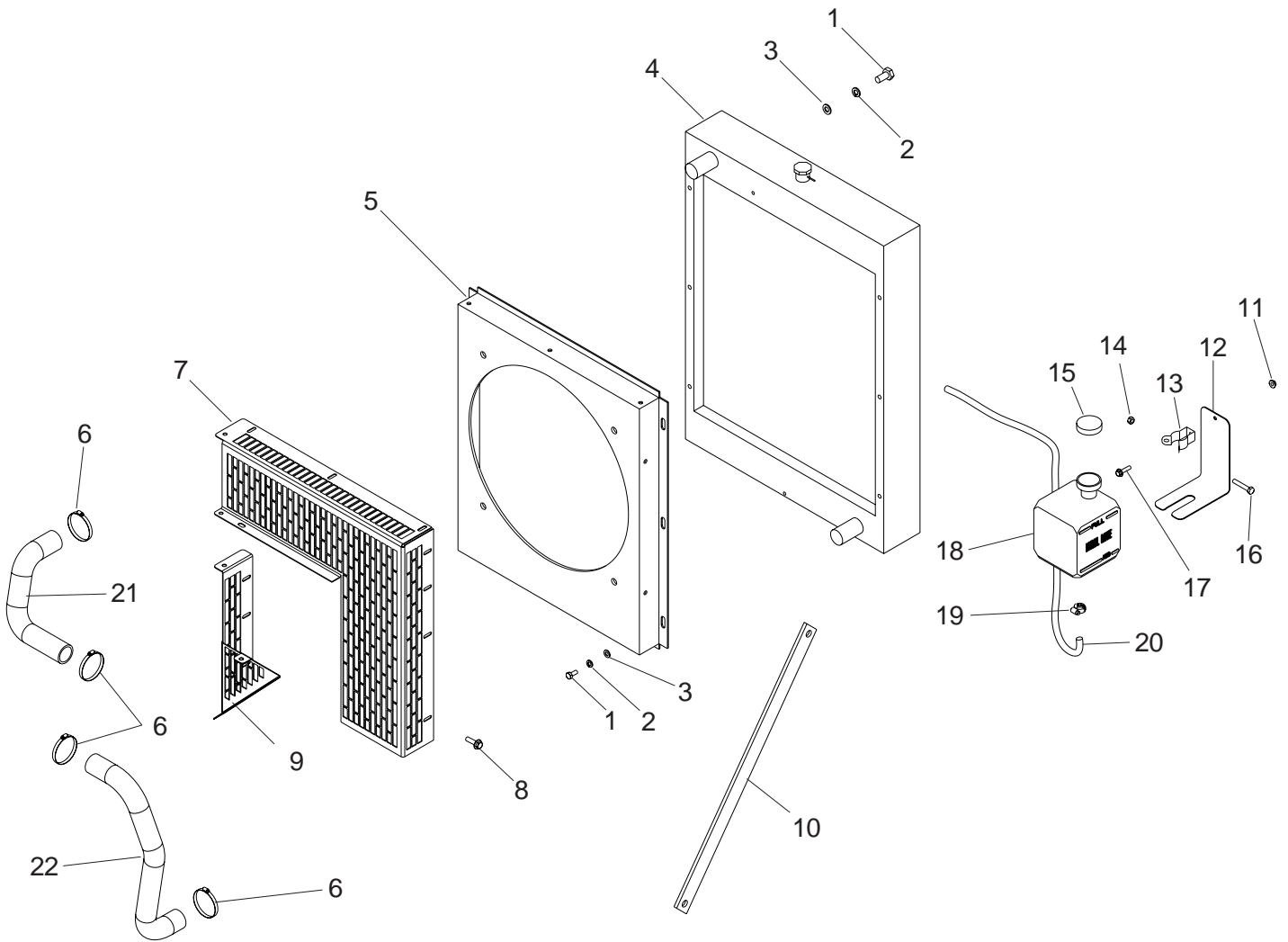

ENGINE COOLING ASSEMBLY

ITEM NO.	PART NO.	QTY	DESCRIPTION
1	60034	12	Screw, .375-16X.750 hx ser flg ZP
2	60206	12	Washer, split lock .375 ZP
3	60386	12	Washer, flat .375 ZP
4	22238	1	Radiator, engine
5	11626B	1	Weldment, fan shroud
6	15422	4	Clamp, hose SAE 20
7	11760B	1	Panel, fan guard (RHT)
8	60115	8	Screw, M6X1.0X12 hx ser flg ZP
9	11769B	1	Weldment, fan guard (LFT)
10	11596B	1	Strut, radiator support
11	60144	1	Nut, .250-20 nylock ZP
12	22419B	1	Bracket, support overflow jug .5 gal.
13	19726	1	Clamp, overflow bottle
14	60047	1	Nut, M6 hx lock class 6 DIN985 ZP
15	19714	1	Cap, overflow bottle
16	60014	1	Screw, M6X1.0X35 hx GR8.8 DIN933 ZP
17	60135	1	Screw, M6X1.0X20 hx ser flg ZP
18	20287	1	Jug, overflow 2 qt. (.5 gal.)
19	14216	1	Clamp, hose SAE 04
20	19220	1	Hose, overflow
21	12064	1	Hose, radiator upper
22	12356	1	Hose, radiator lower

ENGINE ASSEMBLY

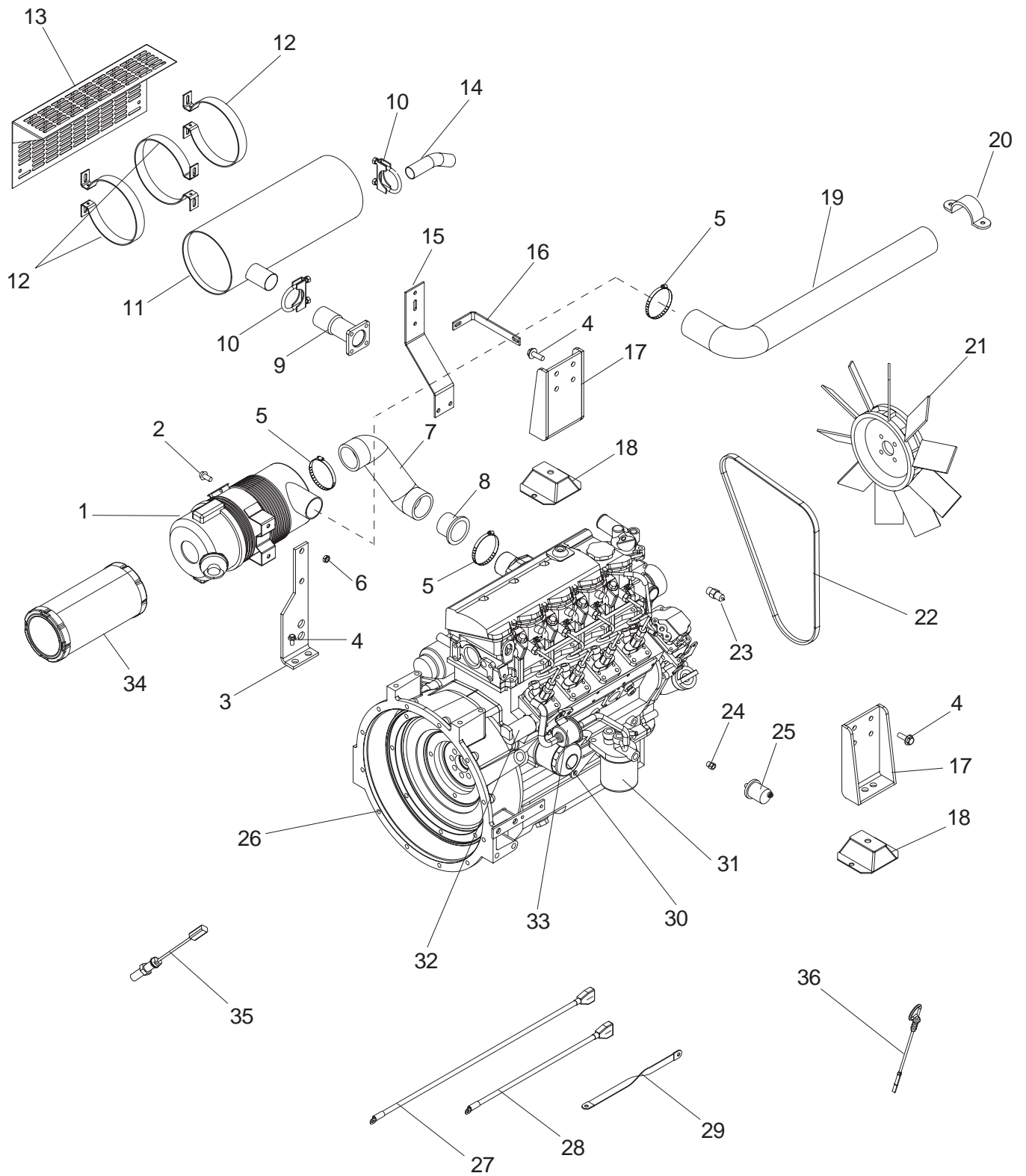

ENGINE ASSEMBLY

ITEM NO.	PART NO.	QTY	DESCRIPTION
1	21505	1	Assembly, air filter
2	60009	4	Screw, M8X1.25X25 hx ser flg ZP
3	12087B	1	Bracket, air filter
4	60018	14	Screw, M10X1.25X20 hx ser flg
5	60316	3	Clamp, hose - SAE 32
6	60342	4	Nut, M8X1.25 hx GR8.8 SS
7	22320	1	Hose, air filter
8	19552	1	Insert, air hose reducer 1.75-2.0
9	12421B	1	Weldment, exhaust flange
10	25455	2	Clamp, 1.5" muffler
11	12608	1	Muffler
12	12606B	3	Bracket, muffler
13	12612B	1	Heat shield
14	12683B	1	Pipe, exhaust
15	12634B	1	Bracket, muffler mounting
16	12635B	1	Bracket, muffler support
17	11471B	2	Weldment, engine mount
18	11524	2	Compression mount, 4.38x4.00x1.50
19	12637	1	Hose, air inlet
20	60821	1	Strap, plastic
21	19258	1	Fan, 15.75 in.
22	22258	1	Belt, fan - 4LE1-PV05
23	19247	1	Sensor, temperature (small)
24	19232	1	Fitting, .125NPTF X .125-28 BSP male
25	18106	1	Sensor, oil pressure
26	18064	1	Engine, 4LE1PV05
27	15074	1	Cable, battery - 4 AWG X 38 in. red
28	15073	1	Cable, battery - 4 AWG X 25 in. blk .38 lug
29	19042	1	Strap, braided ground - 10 in.
30	15183	1	Filter, oil - Isuzu (3LB,3LD,4LE)
31	15331	1	Fuel filter element
32	22893	1	Solenoid, fuel shutdown
33	16205	1	Pump, fuel - ISUZU 4LE1
34	19270	1	Element, air filter
35	18105	1	Sensor, magnetic pickup
36	23899	1	Dipstick, oil, Isuzu 4LEPV05
37	24036	1	Harness, engine (not shown)
38	22430	1	Engine manual, workshop - ISUZU 4LE1

CONTROL PANEL ASSEMBLY FOR UNITS BUILT PRIOR TO MAY 2006

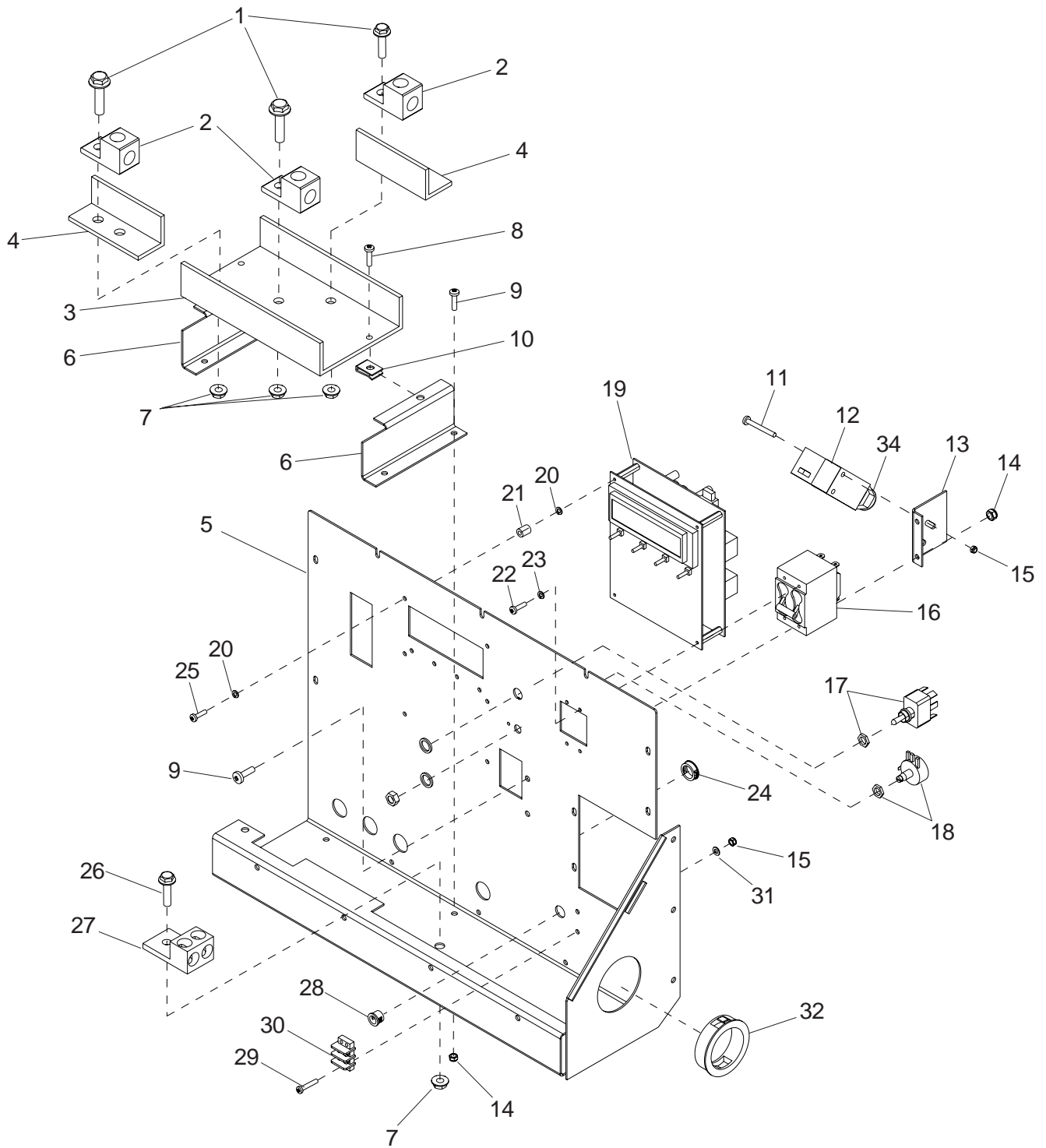

CONTROL PANEL ASSEMBLY - FOR UNITS BUILT PRIOR TO MAY 2006

ITEM NO.	PART NO.	QTY	DESCRIPTION
1	60160	3	Screw, M8X1.25X30 hx ser flg ZP
2	65225	3	Lug, terminal single #6-250 MCM
3	12065	1	Channel, glastic
4	12066	2	Angle, glastic
5	11695W	1	Panel, control
6	11811W	2	Bracket, glastic plate - MLG 25
7	60020	3	Nut, M8 hx ser flg lock ZP
8	60062	3	Screw, 10-32X.750 pan hd phil ZP
9	60044	2	Screw, M5X0.8X12 pan hd phil ZP
10	60738	2	Nut, 10-32 speed u-type ZP
11	60045	2	Screw, M4X35 pan hd phil ZP
12	18111	1	Switch, lockout (1 NO)(1 NC)
13	11742B	1	Bracket, lockout switch
14	60038	2	Nut, M5 hx nylock DIN985 ZP
15	60057	4	Nut, M4 hx DIN934 - 8 ZP
16	65429	1	Breaker, 100A, 250V, 2 pole, w/aux cont.
17	25078	1	Switch, toggle (auto/off/manual)
18	18113	1	Potentiometer, 2.5K 2 watt
19	25651	1	Board, controller - liquid cooled
20	60058	12	Washer, split lock #6 ZP
21	25657	6	Mount, compression - control board
22	60083	16	Washer, split lock M3 DIN127 ZP
23	60046	4	Screw, 6-32X.750 pan hd phil ZP
24	19227	4	Bushing, .812 OD x .625 ID
25	60190	10	Screw, 6-32X.312 pan hd phil ZP
26	60009	3	Screw, M8X1.25X25 hx ser flg ZP
27	18614	1	Lug, terminal dual #6-250MCM 2 hole
28	19163	1	Bushing, .500 x .375 ID
29	60355	2	Screw, M4X25 pan hd phil
30	18890	1	Terminal block, 2-pos
31	60084	2	Washer, flat M4
32	18496	1	Bushing, 2.50 x 2.00 ID
33	11808W	1	Plate, lug door support
34	15864	1	Strain relief - .50 NPT watertight
35	11987	1	Decal, control panel (not shown)
36	11707	1	Assembly, control panel

**CONTROL PANEL ASSEMBLY, NEW STYLE
FOR UNITS BUILT AFTER MAY 2006**

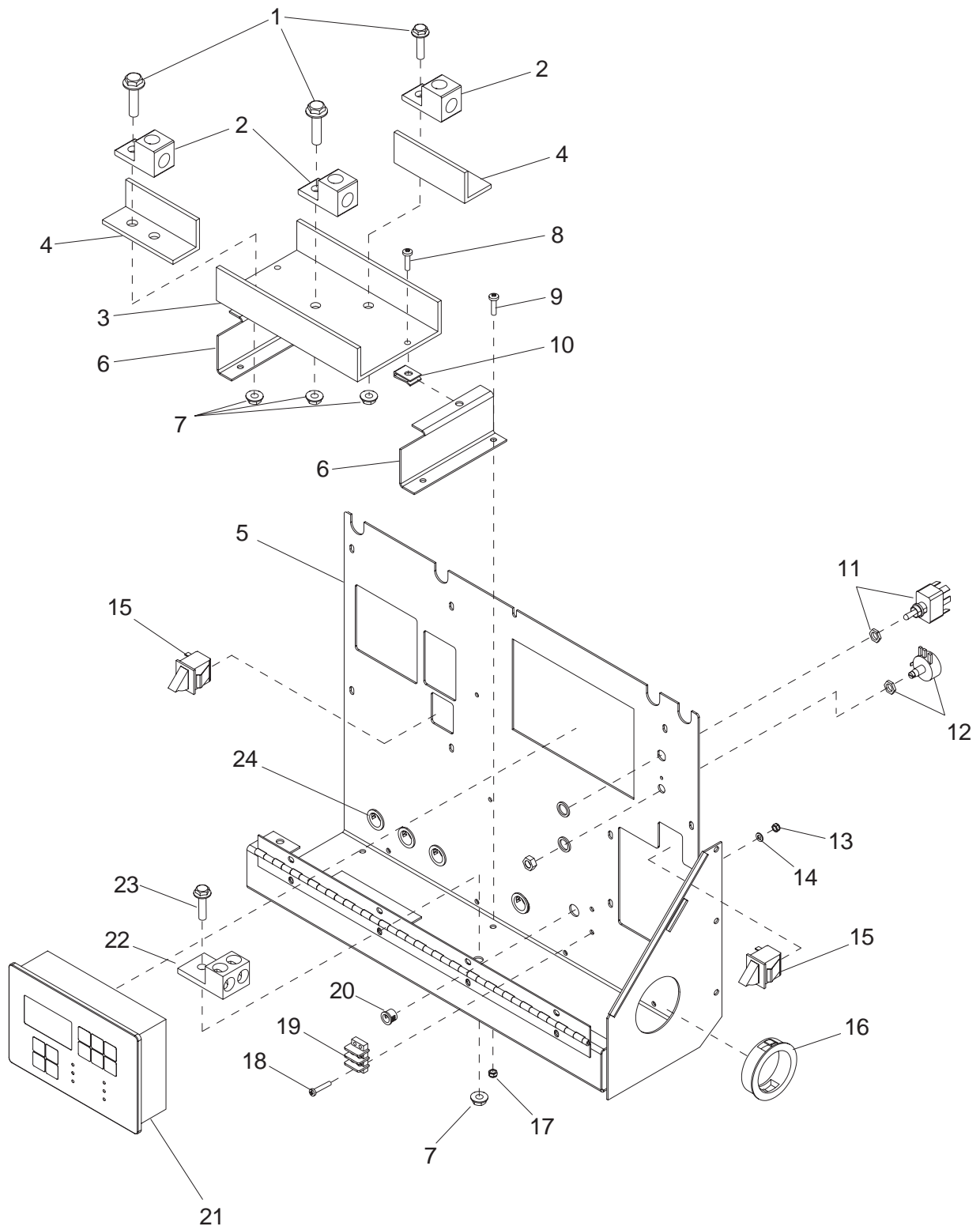

CONTROL PANEL ASSEMBLY, NEW STYLE - FOR UNITS BUILT AFTER MAY 2006

ITEM NO.	PART NO.	QTY	DESCRIPTION
1	60160	3	Screw, M8X1.25X30 hx ser flg
2	65287	3	Lug, terminal single #6-350 MCM
3	12065	1	Channel, glastic
4	12066	2	Angle, glastic
5	12629W	1	Panel, control
6	11811W	2	Bracket, glastic plate - MLG 25
7	60020	7	Nut, M8 hx ser flg lock
8	60062	3	Screw, 10-32X.750 pan hd phil
9	60044	2	Screw, M5X0.8X12 pan hd phil
10	60738	2	Nut, 10-32 speed u-type
11	25077	1	Switch, toggle - SPST 20A VAC
12	18113	1	Potentiometer, 2.5K 2 watt
13	60057	4	Nut, M4 HX
14	60084	2	Washer, flat M4
15	12632	2	Switch, trigger safety, N.O. & N.C.
16	18496	1	Bushing, 2.50 x 2.00 ID
17	60038	4	Nut, M5 HX nylock
18	60355	2	Screw, M4X25 pan hd phil
19	18890	1	Terminal block, 2-pos
20	19163	1	Bushing, .500 x .375 ID
21	24129	1	Controller, eng/gen - programmed
22	18614	1	Lug, terminal dual #6-250MCM 2 hole
23	60009	3	Screw, M8X1.25X25 hx ser flg
24	19227	4	Bushing, .812 OD x .625 ID
--	18934	1	Guard, potentiometer (not shown)
--	12742	1	Decal, control panel (not shown)
--	12628	1	Assembly, control panel

**CONTROL BOX ASSEMBLY
FOR UNITS BUILT PRIOR TO MAY 2006**

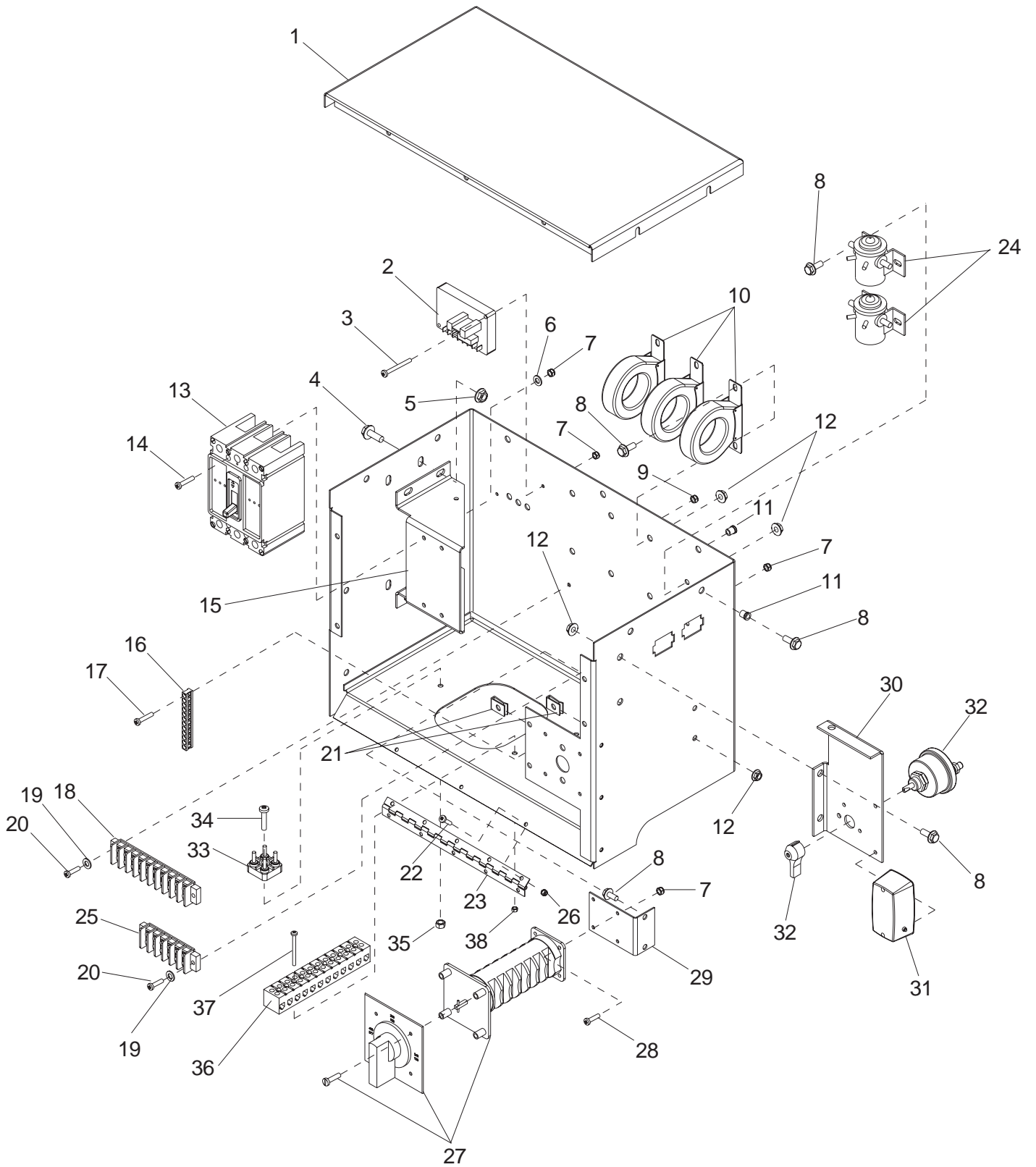

CONTROL BOX ASSEMBLY - FOR UNITS BUILT PRIOR TO MAY 2006

ITEM NO.	PART NO.	QTY	DESCRIPTION
1	11701B	1	Panel, top control box - MLG25
2	18556	1	Regulator, voltage - SE 350
3	60045	2	Screw, M4X35 pan head phil ZP
4	60114	4	Screw, M8X1.25X20 hx ser flg ZP
5	60020	4	Nut, M8 hx ser flg lock ZP
6	60084	6	Washer, flat M4
7	60051	12	Nut, M4 hx nylock
8	60115	12	Screw, M6X1.0X12 hx ser flg ZP
9	60061	4	Nut, 10-32 hx nylock ZP
10	65442	3	Transformer, current - 200:5A
11	60023	7	Insert, threaded M6
12	60036	12	Nut, M6 hx ser flg lock ZP
13	65334	1	Breaker, 90A
14	60159	4	Screw, M4X45 pan head phil ZP
15	11727B	1	Bracket, breaker mounting
16	14204	1	Kit, ground bar
17	60396	2	Screw, 10-32X1.250 pan hd phil ZP
18	14203	1	Block, terminal 10 pos.
19	60041	4	Washer, flat M5
20	60062	10	Screw, 10-32X.750 pan hd phil ZP
21	60738	6	Nut, 10-32 speed u-type ZP
22	60044	6	Screw, M5X0.8X12 pan hd phil ZP
23	10081	1	Hinge, continuous -11 in.
24	18081	2	Relay, ignition soleniod (12V-65 A)
25	65163	1	Block, terminal - 6 pos. fork connection
26	60038	6	Nut, M5 hx nylock DIN985 ZP
27	65456	1	Switch, phase - 63A, 3-pos (Y,y,Z)
28	60091	4	Screw, M4X12 pan hd phil ZP
29	11764B	1	Bracket, phase switch
30	12021B	1	Bracket, control box roof
31	11947	1	Light, interior with switch (optional)
32	65498	1	Switch, disconnect (optional)
33	65519	1	Block, terminal, 4 pole stud
34	60146	1	Screw, M6X1.0X20 pan hd ZP
35	60047	1	Nut, M6 hx lock ZP
36	65590	1	Block, terminal - 12 pos. lug type
37	60045	2	Screw, M4X35 pan hd phil ZP
38	60051	2	Nut, M4 hx nylock
39	19351	1	Seal, generator box (not shown)
40	11688	1	Assembly, control box enclosure
41	11703	1	Assembly, control box complete

**CONTROL BOX ASSEMBLY, NEW STYLE
FOR UNITS BUILT AFTER MAY 2006**

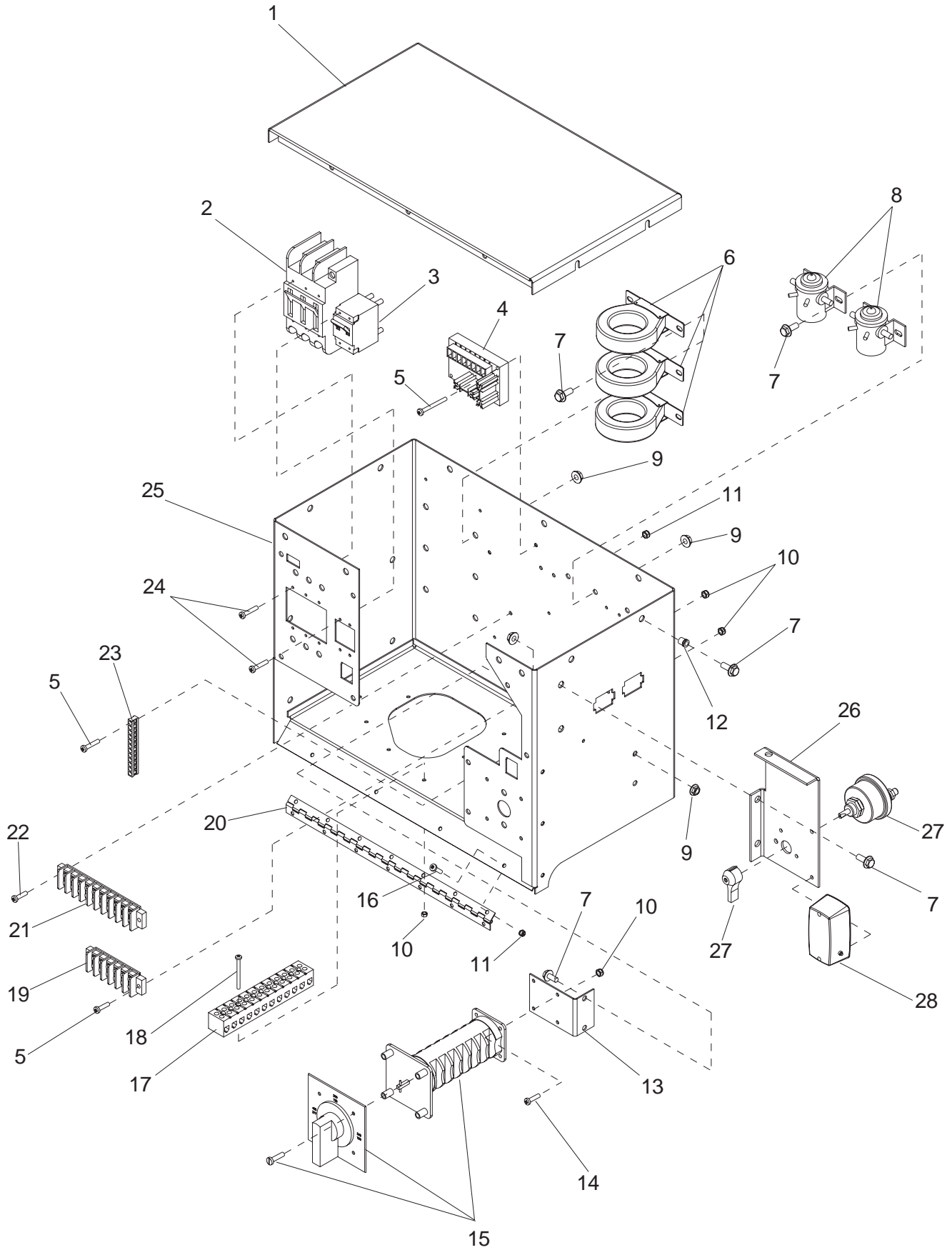

CONTROL BOX ASSEMBLY, NEW STYLE - FOR UNITS BUILT AFTER MAY 2006

ITEM NO.	PART NO.	QTY	DESCRIPTION
1	12694W	1	Panel, top control box - MLG25
2	65619	1	Breaker, 90A, 3 pole
3	65429	1	Breaker, 100A, 250V, 2 pole
4	18556	1	Regulator, voltage - SE 350
5	60355	6	Screw, M4X35 pan head phil
6	65442	3	Transformer, current - 200:5A
7	60115	25	Screw, M6X1.0X12 hx ser flg
8	18081	2	Relay, ignition soleniod (12V-65 A)
9	60036	14	Nut, M6 hx ser flg lock
10	60051	11	Nut, M4 hx nylock
11	60061	6	Nut, 10-32 hx nylock
12	60023	11	Insert, threaded M6
13	11764B	1	Bracket, phase switch
14	60091	4	Screw, M4X12 pan hd phil
15	65456	1	Switch, phase - 63A, 3-pos (Y,y,Z)
16	60044	4	Screw, M5X0.8X12 pan hd phil
17	65590	1	Block, terminal - 12 pos. lug type
18	60045	3	Screw, M4X35 pan hd phil
19	65481	1	Block, terminal - 6 pos.
20	18598	1	Hinge, controller panel - 18.75
21	14203	1	Block, terminal 10 pos.
22	60062	2	Screw, 10-32X.750 pan hd phil
23	14204	1	Kit, ground bar
24	60190	10	Screw, 6-32X.312 pan hd phil
25	12626W	1	Weldment, control box
--	12625	1	Assembly, control box enclosure
--	12624	1	Assembly, control box complete

OPTIONAL FEATURES:

26	12021B	1	Bracket, control box roof (optional)
27	65498	1	Switch, disconnect (optional)
28	11947	1	Light, interior with switch (optional)

LUG DOOR ASSEMBLY

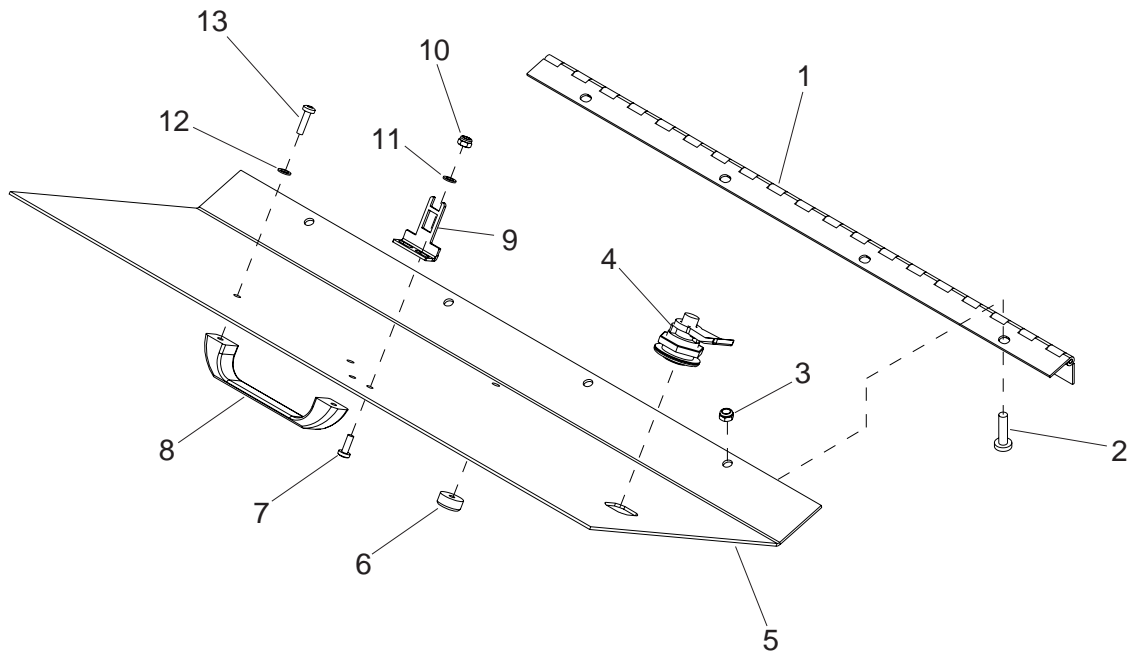

ITEM NO.	PART NO.	QTY	DESCRIPTION
1	18598	1	Hinge, controller panel - 18.75
2	60156	8	Screw, M5X0.8X16 pan hd phil ZP
3	60038	4	Nut, M5 hx nylock DIN985 ZP
4	20762	1	Lock, door - 1/4 turn cam
5	11710W	1	Panel, lug door
	12631W	1	Panel, lug door (for units built after May '06)
6	15215	1	Bumper, rubber
7	60091	2	Screw, M4X12 pan hd phil ZP
8	18893	1	Handle, lug door
9	18112	1	Key, lockout switch (90 DEG)
11	60084	2	Washer, flat M4 DIN125 ZP
10	60051	2	Nut, M4 hx nylock DIN985
12	60043	2	Washer, split lock M5 DIN127 ZP
13	60068	2	Screw, 10-24X.500 pan phil ZP
14	11809	1	Assembly, lug door

GENERATOR ASSEMBLY

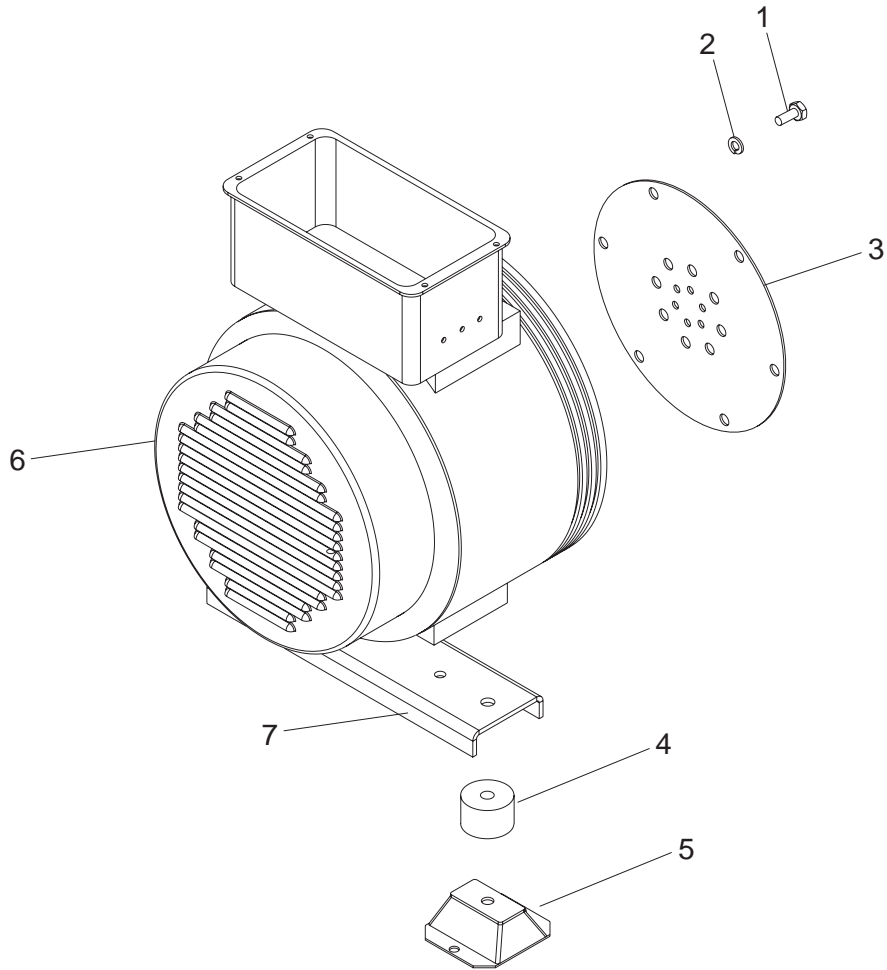

ITEM NO.	PART NO.	QTY	DESCRIPTION
1	60177	6	Screw, M10X1.25X30 hx hd
2	60206	14	Washer, split lock .375 ZP
3	11000	1	Plate, drive - SAE 7.5
4	11515B	2	Spacer, 2.00 dia x 1.00
5	11524	2	Compression mount, engine
6	22899	1	Generator, 282NSL1505
7	11597B	1	Bracket, gen mount

DC WIRING SCHEMATIC, FOR UNITS BUILT PRIOR TO MAY 2006

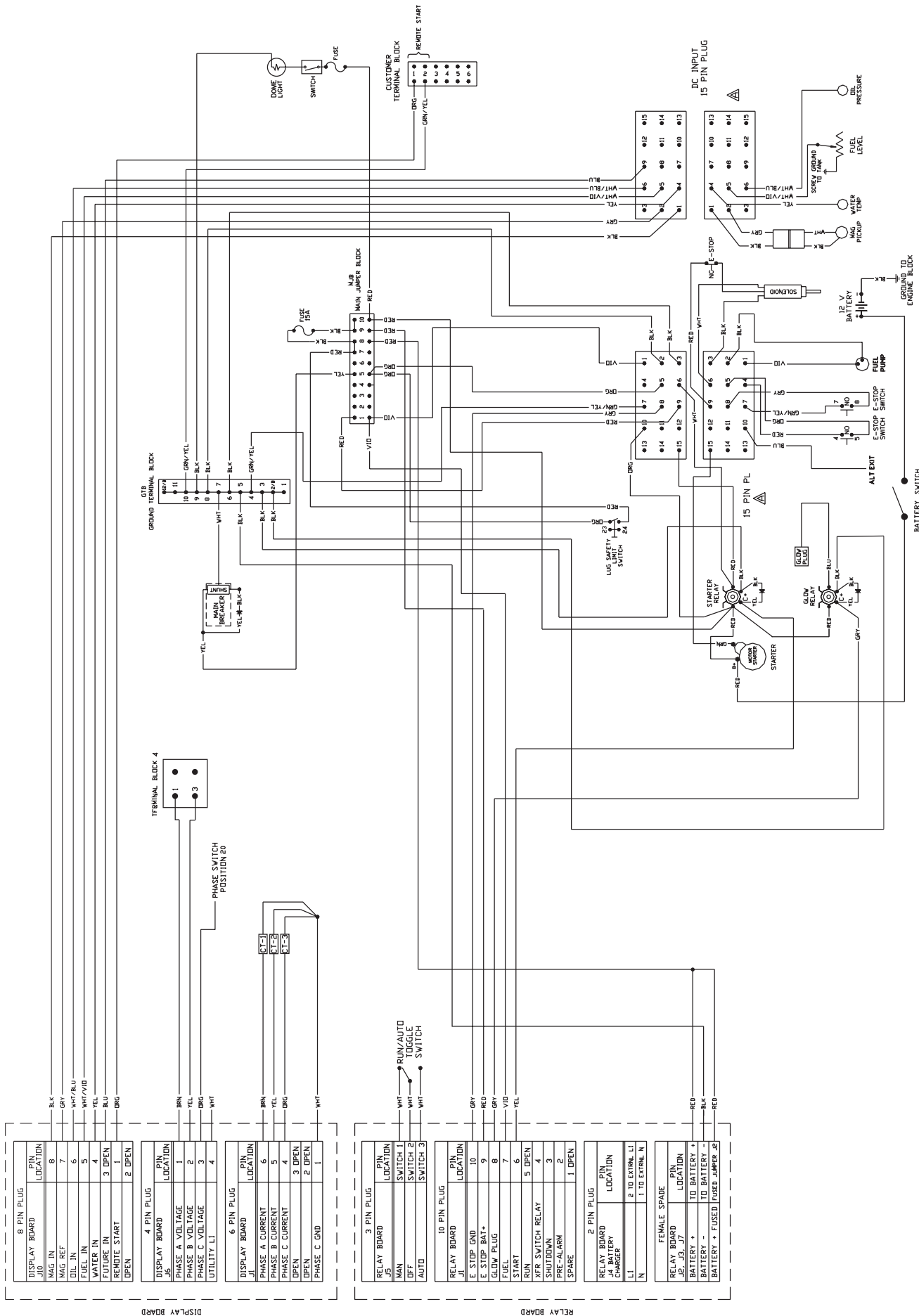

DC WIRING SCHEMATIC, NEW STYLE - FOR UNITS BUILT AFTER MAY 2006

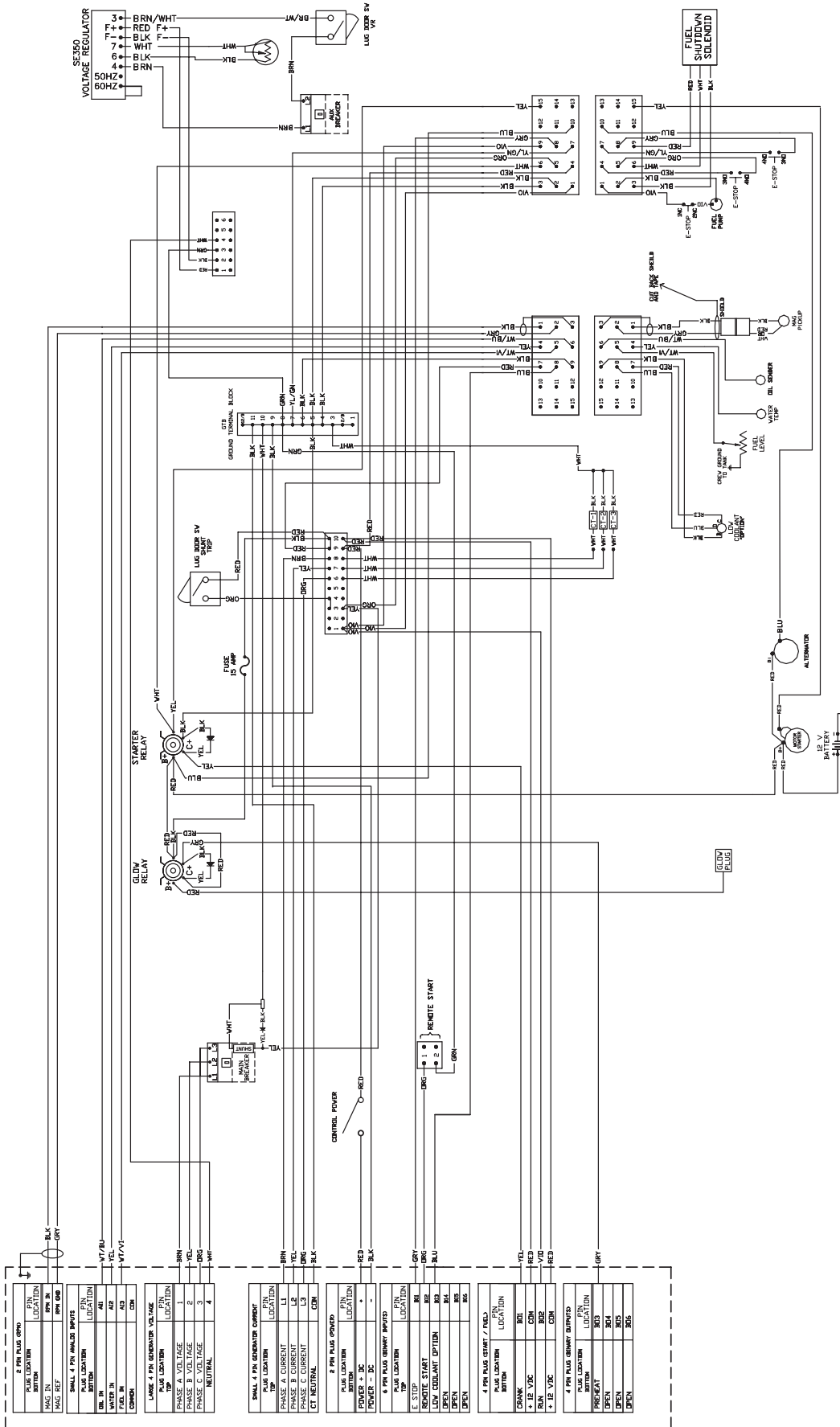

90505 WIRING DIAGRAM, MLG25 DC

AC WIRING SCHEMATIC, FOR UNITS BUILT PRIOR TO MAY 2006

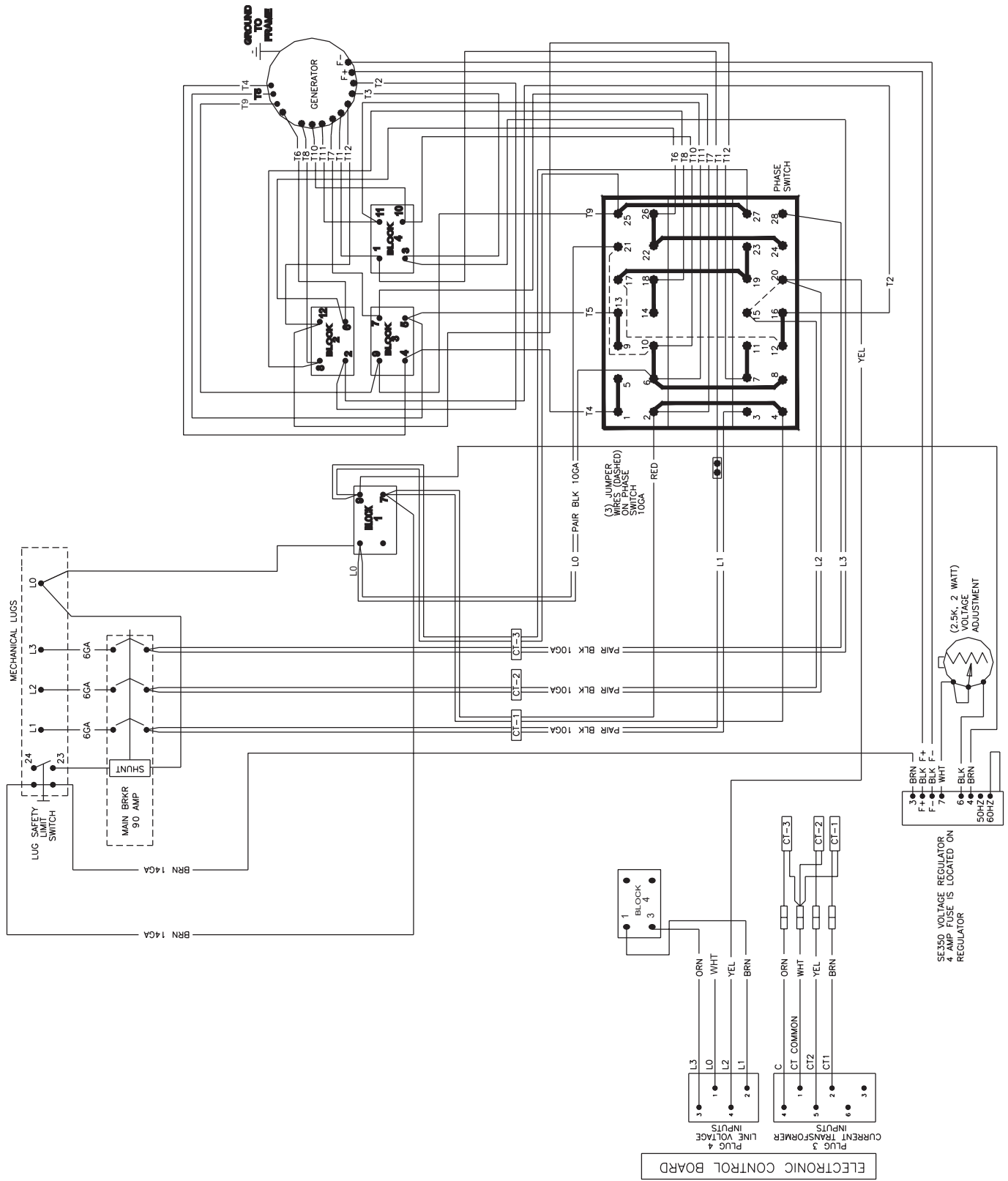

AC WIRING SCHEMATIC, NEW STYLE - FOR UNITS BUILT AFTER MAY 2006

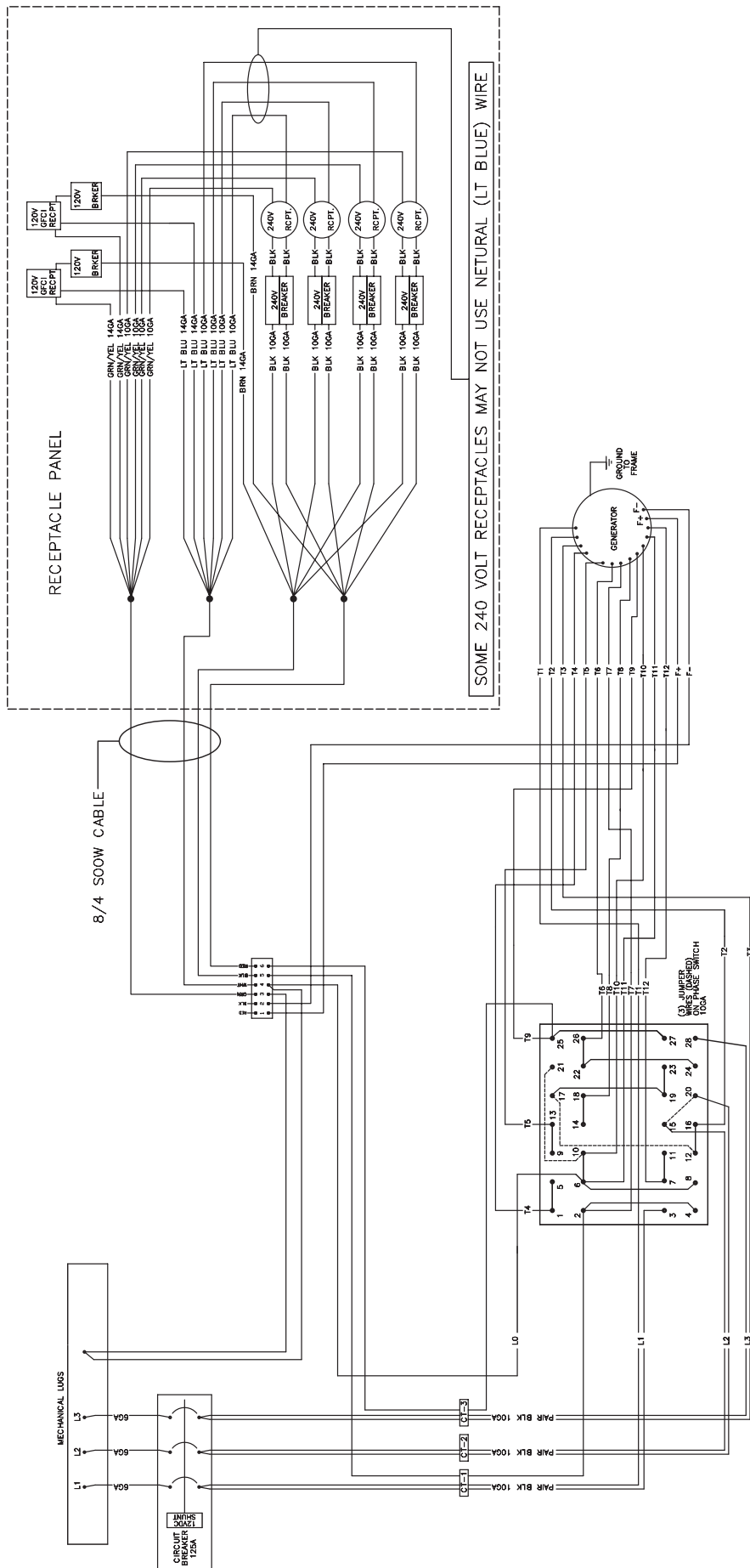

905052 WIRING DIAGRAM, MLG25 AC

**CALIFORNIA PROPOSITION 65
WARNING**

DIESEL ENGINE EXHAUST AND SOME OF ITS CONSTITUENTS ARE
KNOWN TO THE STATE OF CALIFORNIA TO CAUSE CANCER, BIRTH
DEFECTS AND OTHER REPRODUCTIVE HARM.